

The Dogbone Depth Effect of Castellated Beam on Ductility Behavior

R. Firman¹, H. Parung¹ and A. A. Amiruddin¹

¹Departement of Civil Engineering, Universitas Hasanuddin

email: risman.firman7@gmail.com

ABSTRACT

Experimental study of reduced beam section on castellated beam-column was conducted to analyze ductility behavior of castellated beams with "dogbone" as RBS. This study used two types of test beams to examine the effect of "dogbone" made of IWF steel beams 150 x 75 x 5 x 7 mm and then become castellated beam IWF 225 x 75 x 5 x 7 mm. The first sample was RBSC-1 with 150 mm as its width and the second sample was RBSC-2 with 100 mm as its width and the distance of each is 100 mm from the face of the column. Two LVDT100 were placed 30cm from the top of the column to measure displacement that will be occurred. The test was carried out using cyclic load consisting of 8 cycles where each cycle consisted of 3 sub-cycles. Each cycle is given a displacement of 5mm, 10mm, 15mm, 20mm, 40mm, 60mm, 80mm, and 100mm with ram speeds of 0.1 mm / sec. The results showed the capacity of the RBSC-1 showed an average ductility value of 4,143 and RBSC-2 the average ductility value was 4,791 with a difference of 13,525%.

Keywords: Reduced Beam Section; Cyclic loading; Dogbone; Castellated beam

1. INTRODUCTION

Earthquakes are a natural phenomenon that cause many failures/damages to structures. Structural failure can occur due to an inability to maintain its elasticity. During earthquake conditions, the structure must remain elastic while experiencing or receiving earthquake loads from small, medium to large scale. If not, it can cause structural failure, especially the combined area between the beam and column.

Some facts were found in the 1994 Northridge earthquake [1], such as many of the cracks that occurred in the connection area or in the beam column connection. Most cracks occur in the flange weld area under the beam and spread to the column flange area.

Hollow web beams are also called as castellated beams made from hexagonal or square shapes and circular hole models called cellular beams. The main advantage of using castellated beams is the reduction in the total weight of the structure and the amount of steel used. Castellated beams are made of H, I and U beam steel standard by cutting steel profile bodies with a zigzag pattern on the line in the center of the beam. Both parts are shifted or reversed and then combined again with welding.

According to some research that has been done to improve connection performance [2, 3]. Among them is a lot of literature conducted to increase ductility in earthquake loads. One of these strengths is by using a rib on the connection area.

Therefore, a number of breakthroughs or new ideas have been found in designing to obtain column beam connections that make the structure more ductile. One of them is to use the Reduced Beam Section (RBS) method by reducing the beam section in the beam column joint area, which aims to reduce the beam capacity and ensure damage will occur in the RBS area.

Aswad et al [4] experimented using beams reduced by the curved model. This experiment shows that

the damage occurred in the RBS area where the difference in load and deflection under peak load conditions was not significant. Damage is concentrated in the lower surface area of the RBS.

Mara [5] and Parung [6] have examined the variation of the angle and length of the opening with a slit height of $0.6 H$. The profile of solid steel made into castellated beams is IWF 200x100x5.5x8 mm which is loaded with static monotonic loads. The results showed that the opening angle of 60° and the length of the openings $e = 3$ and $b = 9$ cm, gave the best results from the angle and length of the openings with hexagonal shape.

Based on previous research, a strengthening study was carried out between the beam column joints using the Reduced Beam Section (RBS) method combined on a castellated steel beam with a dogbone model. From the combination of castellated beams given the RBS model, it is expected to save costs and also increase the strength of the beam structure itself and the expected plastic joints in the RBS area to avoid sudden structural collapse.

The RBS method can reduce beam stiffness, but can also strengthen column beam joints and can improve the connection performance between columns and castellated beams.

A. Reduce Beam Section (RBS)

Reduced Beam Section (RBS) is a modification of the beam section by providing a reduction in the wing area with a certain distance from the support. This reduction process is carried out in such a way that all yielding and plastic joints occur in this part of RBS. Also, the reduction in the area plays a role in reducing the moment in the column while controlling the occurrence of inelastic deformations in the column. Considering the RBS design is regulated in SNI 03-1729-2015 [7], or uses the AISC 358-16 standard [8] as a reference in the RBS design. The RBS design procedure based on AISC 358-

16 article 5.8 as shown in Figure 1.

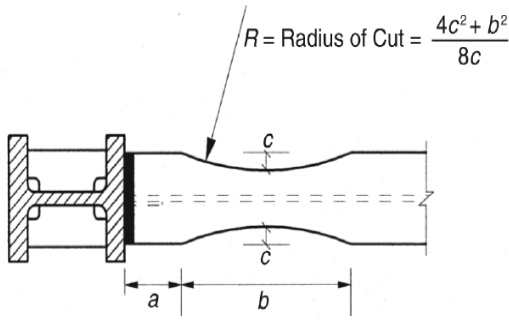

Fig 1. RBS design on beam flanges

Determination of RBS geometry (Figure 1) is

limited to:

$$0,5 \text{ bf} \leq a \leq 0,75 \text{ bf} \dots\dots\dots (1)$$

$$0,65 \text{ d} \leq b \leq 0,85 \text{ d} \dots\dots\dots (2)$$

$$0,1 \text{ bf} \leq c \leq 0,25 \text{ bf} \dots\dots\dots (3)$$

where:

bf : wingspan

d : beam height

B. Ductility

Ductility is the ability of a structure or structural component to not experience a sudden collapse (brittle) but can still experience considerable deformation when the maximum load is reached before the structure collapses. The structure ductility factor is the ratio between the maximum deviation/strain of the structure due to the effect of the earthquake when reaching the collapse threshold condition (Δ_u) and the deviation/strain when the first yielding occurs (Δ_y).

$$\mu = \frac{\Delta_u}{\Delta_y} \dots\dots\dots (4)$$

Where:

μ : Structure ductility

Δ_u : Maximum displacement (mm)

Δ_y : First time yielding (mm)

2. METODOLOGY

The structural model used is the exterior-interior column beam structure. The study was carried out by

experimental testing with lateral loads (cyclic) using RBS method on the castellated beam which will produce the influence of ductility on the specimen. The type used is end plate connection which is also a recommendation as a special moment frame system for medium earthquake-resistant building [6].

Figure 2 describe the setup specimen, while Table 1 show the dimension of RBS. The detailed design of RBSC-1 and RBSC-2 is shown in Figure 3.

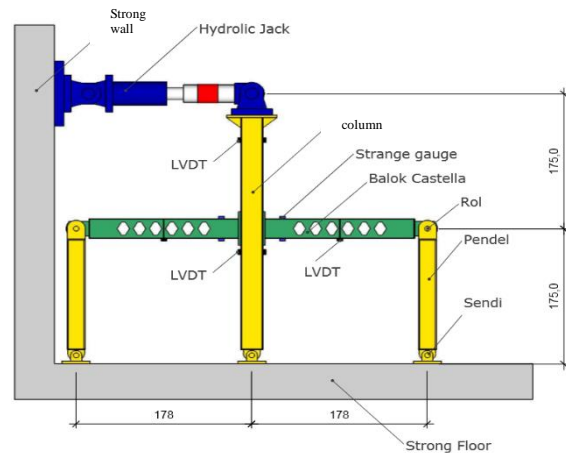

Fig 2. Setup specimen

Table 1. RBS design dimensions

Specimen	RBSC- 1	RBSC- 2
Castellated beams		
distance opening from the column face (mm)	300	300
Opening distance from the column face (mm)	100	100
Variation in the width of RBS (mm)	15	10
Variation in length of RBS (mm)	15	15

There are several steps to get data from testing structures that experience cyclic loads to the plastic boundary, where the principle design of strong column weak beam is used. Specimens are modeled as exterior column beams that are loaded with cyclic loads. Displacement measurements are carried out using LVDT.

The load is applied push and pull based on the displacement control. From the calculation, the displacement in the first yield (Δ_y) is 20 mm. Determination of the amount of displacement (yielding point) for each cycle is $0.25\Delta_y$, $0.5\Delta_y$, $0.75\Delta_y$, Δ_y , and $2\Delta_y$, $3\Delta_y$ and so on, until loading is stopped if there has been a decrease in the load from the previous peak. Gravity load remains constant, lateral cyclic load is given with a displacement rate of 0.1 mm/sec.

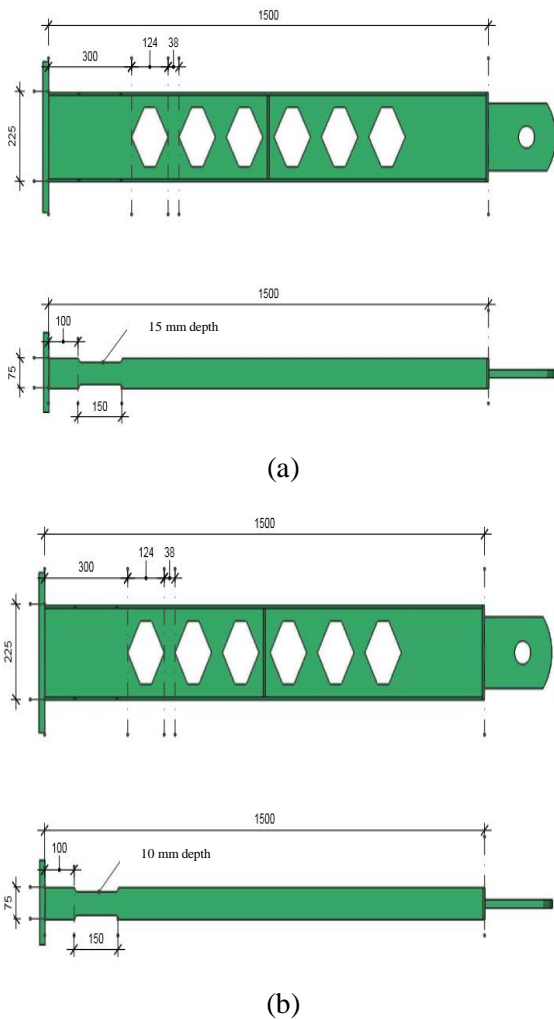

Fig 3. a). RBSC-1 with 15 mm depth; b). RBSC-2 with 10 mm depth

3. RESULT AND DISCUSSION

The loading cycle consists of 8 cycles, where each cycle has 3 sub-cycles. Each cycle is given a displacement

of 5mm, 10mm, 15mm, 20mm, 40mm, 60mm, 80mm and 100mm. Figure 5 shows the loading history.

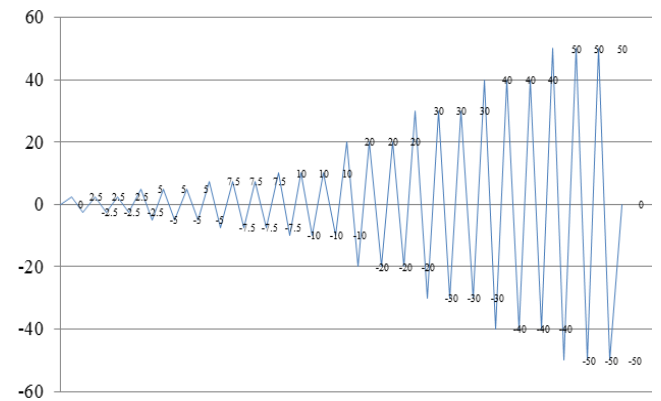

Fig 5. Loading history with displacement control

Determination of the yielding point is based on the relationship of the yield stress of steel ($f_y = 240$ MPa) and the modulus of elasticity ($E_s = 200000$ MPa), obtained yield strain of 1200μ .

A. RBSC-1

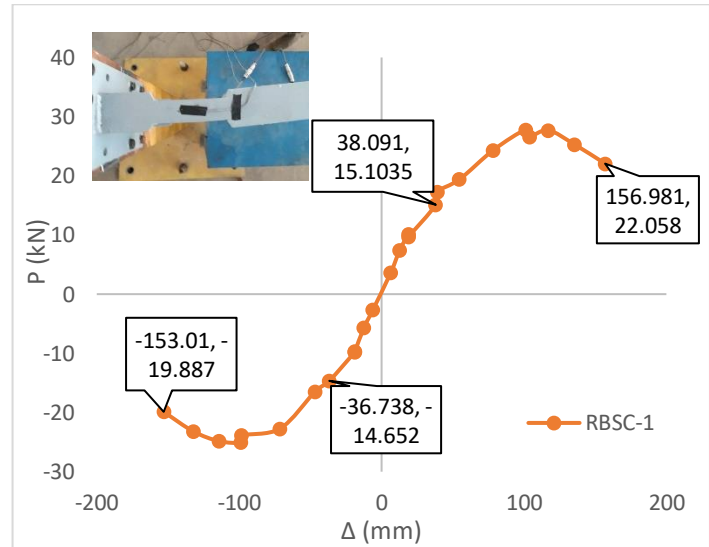

Fig 6. Backbone curve of RBSC-1

Figure 6 presents the yielding load of 15.103 kN in the positive direction (tension) and -14.652 kN for the negative direction (tensile) which shows the backbone curve of the yielding load and the maximum load with displacement.

From the data in table 2, the structure ductility value can be calculated. In the tension condition, the

ductility value is 4.121 and at the tensile condition of 4.165. Then the average structure ductility is 4.143.

Table 2. Load-displacement of RBSC-1

Condition	Push (+)		Pull (-)	
	Load (kN)	Displacement (mm)	Load (kN)	Displacement (mm)
Yield	15.103	38.091	14.652	36.738
Ultimate	22.058	156.981	19.887	153.010

B. RBSC-2

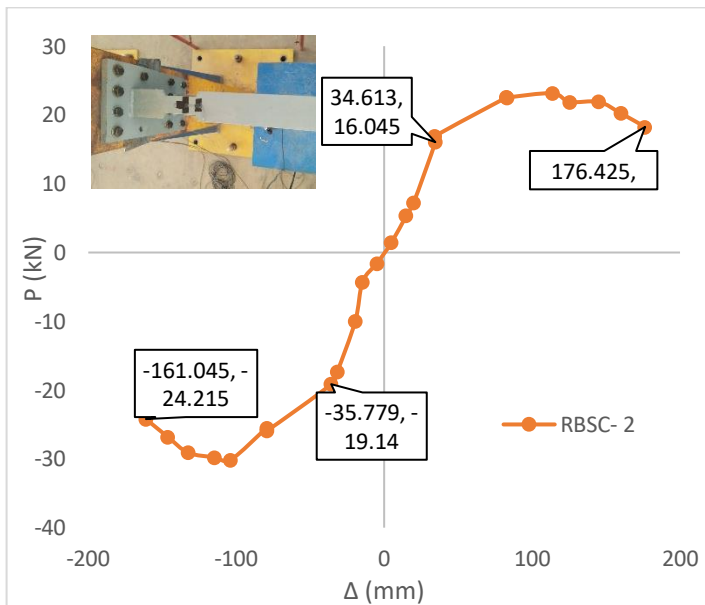

Fig 7. The backbone curve of RBSC-2

From Figure 7, the yielding load is 16.045 kN in the positive direction (tension) and -19.14 kN for the negative direction (tensile) which shows the backbone curve of the yielding load and the maximum load with displacement.

Table 3. Load-displacement of RBSC-2

Condition	Push (+)		Pull (-)	
	Load (kN)	Displacement (mm)	Load (kN)	Displacement (mm)
Yield	16.045	34.613	19.140	35.779
Ultimate	18.266	176.425	24.215	161.015

From table 3, the structure ductility value in tension condition is 5.01, while in tensile condition is 4.50. Then the average structure ductility is 4.755.

RBSC-1 and RBSC-2 can be categorized into partial ductility. It was found that RBSC-2 was slightly more ductile than RBSC-1. This indicates that RBSC-2 with a smaller dogbone depth has better ductility compared to RBSC-1.

4. CONCLUSIONS

From the above description, it can be concluded that RBSC-2 more ductile than RBSC-1 with the ductility of 4.755 and 4.143, respectively. The greater the depth dogbone at RBS, the lower the ductility.

REFERENCES

- [1] Miller, D. K. (1998). Lesson learned from the Northridge earthquake, *Engineering Structures*, 20 (4-6), 249-260.
- [2] Momenzadeh, S., Kazemi, M. T., & Asl, M. H. (2017). Seismic performance of reduced web section moment connections. *International Journal of Steel Structures*, 17(2), 413-425.
- [3] Plumier, A. (1997). *The dogbone: back to the future. Engineering Journal-American Institute of Steel Construction*, 34, 61-67.
- [4] Aswad, N. H., Parung, H., Irmawaty. R., & Amiruddin, A. A. (2017). Evaluasi Posisi Jarak Buka Balok Kastella Terhadap Daktilitas. Konferensi Nasional Teknik Sipil 11., Universitas Tarumanagara, Oktober 2017.
- [5] Mara J, Parung H, Tanijaya J, Djamiluddin R (2016). Flexural Capacity And Ductility Of Castella Beam Due To Cyclic Load. *ARPJN Journal of Engineering and Applied Sciences*, ISSN 1819-6608
- [6] Parung H, et, a; (2013) *Eksperimental Study On Castellated Beam Under Monotonic Loading*, Konferensi Nasional Pasca Sarjana Teknik Sipil,

ITB, November.

- [7] National Standardization Agency (2002). “Standar Perencanaan Ketahanan Gempa Untuk Struktur Bangunan Gedung SNI – 1726 – 2002”. Jakarta
- [8] American Institute of Steel Construction (AISC). (2016) *Prequalified Connections for Special and Intermediate Steel Moment Frames for Seismic Applications (ANSI/AISC 358-16)* AISC Inc. Chicago.

