

# Fluid Flow Analysis of Jacket Cooling System for Marine Diesel Engine 93 KW

Aguk Zuhdi Muhammad Fathallah<sup>1</sup>, Wolfgang Busse<sup>2</sup>, Fadhil Rizki Clausthaldi<sup>3</sup>

**Abstract**—the main function of cooling system is to control the temperature in the engine. To know the flow in the jacket cooling system for marine diesel engine 93 KW and the couple simulation between 1D modeling and 3D modeling, the methodology used. The analysis process was performed by using 3 different softwares. The methodology to analysis fluid flow is CFD (computational fluid dynamic) with steps were problem identification, literature study, design the jacket cooling system based on the cummin diesel engine 93 KW, 1D modeling of cooling system, 3D modeling fluid flow in jacket cooling system, and conclusion. The input of 3D jacket cooling simulation are mass flow, fluid temperature, wall temperature, and heat transfer. The result from this bachelor thesis is fluid flow in jacket cooling system and another parameter output such as temperature flow and velocity if fluid in the jacket cooling system. The result of the flow in jacket cooling is much turbulence in various are of jacket cooling its mean the jacket cooling have a good efficiency of heat transfer, and the fluid temperature show the increasing temperature from inlet to outlet because of heat transfer happen in the jacket cooling between wall of jacket cooling and fluid. The engine speed will affect the cooling system, if the engine speed is increasing, the speed of flow will increase because the cylinder block need more coolant and the temperature of cylinder block will increase

**Keywords**—jacket cooling system, fluid flow, simulation, 3D modeling

## I. INTRODUCTION

Developments of science and technology are very quick to give a good impact as well as a great benefit for humans in many areas of life. It can be seen by the increasing number of equipment that has been created by humans in a variety of models, shapes and capabilities in terms of the use of relatively superior to conventional equipment.

Marine diesel engine is widely used for the needs in the field of marine propulsion, because the shape is compact and economic. For marine diesel engine with 93 kW power are needed for vessels with a tonnage between 15-20 GT (especially for fishing vessels). Associated with one of the research laboratories in motor fuel, Shipping Systems Engineering Department, Faculty of Marine Technology, Institute of Technology will require an analysis related to the performance of marine diesel that had been established earlier by the method of reverse engineering.

In many engines, one of the most important systems in engine is cooling system. Cooling system has a purpose to cooling down the part of the engine. The part of engine has a different work which made the part has a high temperature, the temperature of the component of

the engine has a limits, if the temperature through the limits, it will be dangerous for the engine and can made the engine breakdown and cannot work anymore. So in this case, the cooling system is to maintain the temperature of the engine to make the temperature steady in the normal temperature. The fluid of the cooling system has a standard temperature to cooling down the engine components.

Juniono Raharjo, Institut Teknologi Sepuluh Nopember (ITS) student's bachelor thesis in 2015, it discusses about "Design marine diesel using Reverse Engineering Method" fishing vessel with capacity around 15-20 GT. The result of the thesis is engine design with 93 KW. In this engine, there are some parts that have not been study include jacket cooling system [1].

## II. LITERATURE REVIEW

### A. Cooling system

The cooling system is a system of parts and fluid that work together to control an engine's operating temperature for optimal performance. The system is made up of passages inside the engine block and heads, a water pump and drive belt to circulate the coolant, a thermostat to control the temperature of the coolant, a radiator to cool the coolant, a radiator cap to control the pressure in the system, and hoses to transfer the coolant from the engine to the radiator

The main purpose of the cooling system is to remove the heat from the engine generated in the combustion process. In addition, the cooling system maintains the charge air and lubricating oil temperatures at nominal values. A secondary function for the system is to preheat the engine block during operating breaks. Indirect cooling meaning the heat is released to a closed coolant circuit instead of releasing the heat directly to cooling air without using a cooling agent. In the cooling system the cooling water is circulated through the heat sources of the engine. The heat is conducted to the cooling water

Aguk Zuhdi Muhammad Fathallah, Department of Marine Engineering, Institut Teknologi Sepuluh Nopember, Surabaya 60111, Indonesia, Email : fathalaz@its.ac.id

Wolfgang Busse, Department of Marine Engineering, Institut Teknologi Sepuluh Nopember, Surabaya 60111, Indonesia, Email :

Fadhil Rizki Clausthaldi, Double Degree Undergraduate Student, Department of Marine Engineering, Institut Teknologi Sepuluh Nopember, Surabaya 60111, Indonesia, Email : fadhil.clausthaldi@gmail.com

and the circulating motion carries the heat away from the heat sources. The cooling system also includes a method to remove the heat load from the operating cycle to the environment. For example radiators, cooling towers, central coolers and box coolers are used for this purpose. In most cases the cooling system consists of two separate cycles that are referred to as primary cycle and secondary cycle. The primary cycle is always a closed cycle that circulates the cooling water in the heat sources and is cooled down by a heat exchanger. Treated fresh water is used as a cooling agent on primary cycle and glycol is used as an additive to prevent freezing when operating in cold conditions. The heat exchanger in the primary cycle serves as a connection for the heat to transfer to the secondary cycle which then takes care of the heat disposal. There are also applications where the heat exchanger in the primary cycle serves directly as a heat exposer method example when using radiator [2]

### B. Thermodynamic and Heat Transfer

The First Law of Thermodynamics states:

**“Energy can neither be created nor destroyed, only altered in form.”**

For any system, energy transfer is associated with mass and energy crossing the control boundary, external work and/or heat crossing the boundary, and the change of stored energy within the control volume. The mass flow of fluid is associated with the kinetic, potential, internal, and "flow" energies that affect the overall energy balance of the system. The exchange of external work and/or heat complete the energy balance.

The First Law of Thermodynamics is referred to as the Conservation of Energy principle, meaning that energy can neither be created nor destroyed, but rather transformed into various forms as the fluid within the control volume is being studied. The energy balance spoken of here is maintained within the system being studied. The system is a region in space (control volume) through which the fluid passes. The various energies associated with the fluid are then observed as they cross the boundaries of the system and the balance is made.

In the case of combined heat transfer, it is common practice to relate the total rate of heat transfer, the overall cross-sectional area for heat transfer ( $A_o$ ), and the overall temperature difference ( $\Delta T_o$ ) using the overall heat transfer coefficient ( $U_o$ ). The overall heat transfer coefficient combines the heat transfer coefficient of the two heat exchanger fluids and the thermal conductivity of the heat exchanger tubes.  $U_o$  is specific to the heat exchanger and the fluids that are used in the heat exchanger.[3].

$$Q = U_o A_o \Delta T_o$$

### C. Computational Fluid Dynamic

Fluid flows are governed by partial differential equations which represent conservation laws for the mass, momentum, and energy. Computational Fluid Dynamics (CFD) is the art of replacing such PDE systems by a set of algebraic equations which can be solved using digital computers. [4]

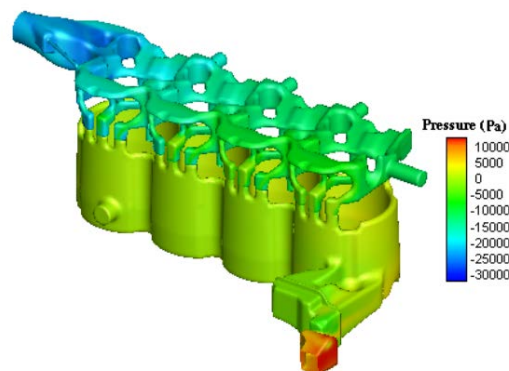
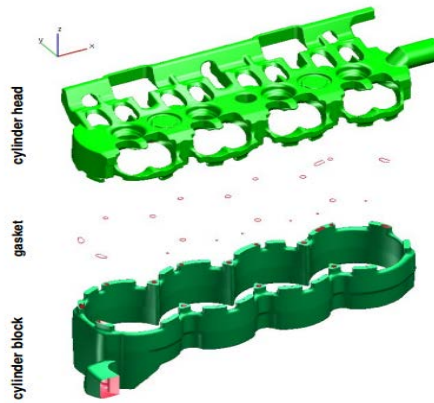

Figure. 1. total pressure distribution in jacket coolant [8]

CFD has made rapid advances over the years and is now used as an effective tool in the analysis and visualization of fluid flows in complex systems including the engine cooling jackets. Along with visualizing the flow development in the jacket passages, CFD techniques are also applied to estimate temperature distribution over the entire engine block. It also helps to study and understand complex phenomena that commonly occur in cooling jackets, like cavitation and nucleate boiling. [5]

The complex shape of the cooling jacket is influenced by multiple factors including the shape of the engine block and optimal temperature at which the engine runs. A very large cooling jacket would be effective in transporting heat away from the cylinders, however, too large of a geometry results in extra weight to be transported. Also, engineers would like the engine to reach its optimal operating temperature quickly. In the following, we describe the major components of the geometry and the design goals of the mechanical engineer responsible for the analysis. [6]



**Figure. 2.** The cooling jacket has been split apart for illustration. The geometry consists of three primary components: (top) the cylinder head, (middle) the gasket, and (bottom) the cylinder block [9].

Even for a simple 1D cooling system model a lot data for different components needs to be obtained. It can once again be recommended for engineers to go through the GTISE tutorials and try building simple models according to become familiar with GT-ISE interface. In addition one should look at cooling systems and thermal management tutorials to get a better understanding on how the cooling model is supposed to operate and what are the recommended settings and

parameters for template objects and the simulation itself. [7]

### III. RESULT AND DISCUSSION

#### A. Engine Specification Data

Simulation done by marine diesel engine which has been design in previous study. The following is a specification of the engine data will be used in the simulation.

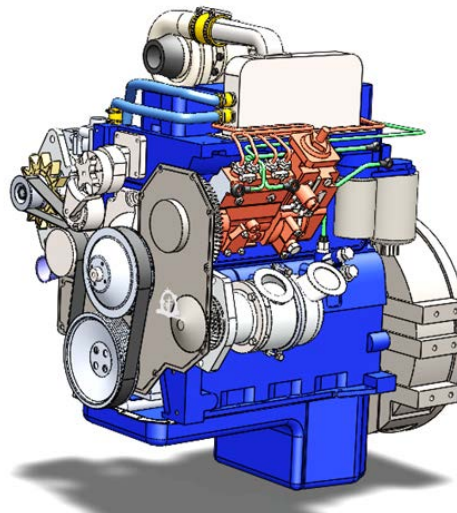

**Figure. 3.** Marine diesel engine 93 KW[1]

The table 1 explain about engine data information. Engine data information explain about specification engine using in this simulation. In this simulation using

diesel engine Cummins model 4BTA3.9-M125. For more information, see table 1:

TABLE 1.  
DIESEL ENGINE DATA

Engine Type	Diesel engine
No. Of cylinder	4
Bore	102 mm
Stroke	120 mm
Inlet Valve	45 mm ( clearance =0,25 mm)
Outlet Valve	43 mm ( clearance =0,51 mm )
Displacement	3.9 lt
Compression Ratio	1: 16.51
Firing order	1-3-4-2
Length of connection Rod	191,7 mm

Cooling system modeling obtained from the existing data and needed to complete simulations and analysis in this

thesis. Figure 4 is 1D modeling of cooling system in diesel engine

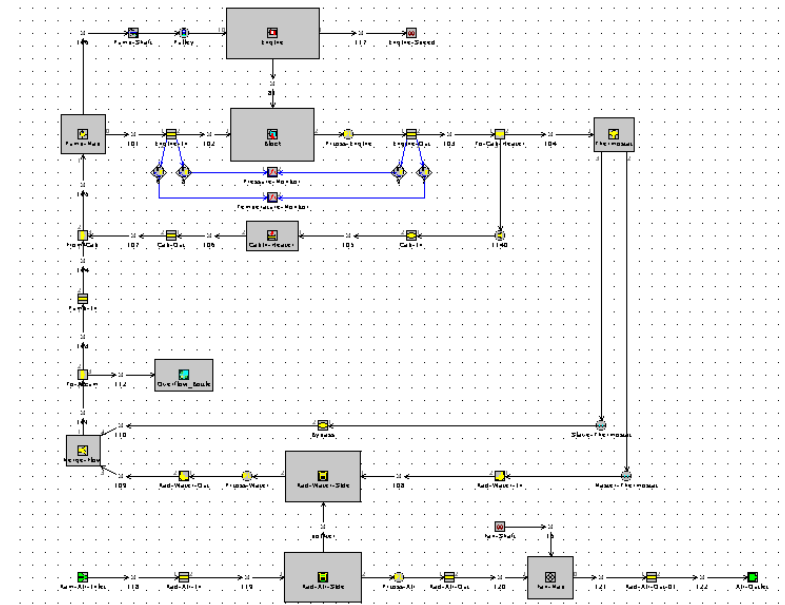

Figure. 4. 1D cooling system modeling

Table 2 is the input for jacket cooling 3D simulation. The domain configuration is fluid block and the time configuration is steady

TABLE 2.  
 INPUT FLUID MODEL PARAMETERS

Fluid name	Water
Fluid type	incompressible
Reference pressure	101325.0 Pa
Reference temperature	330.0 K
Cp	4182.0 J/kg K
Heat conduction law	Prandtl
Prandtl number	7.02
Viscosity law	Constant viscosity
Kinematic viscosity	1.01e-006 m <sup>2</sup> /s
Density law	Boussinesq
Density	1001.0 Kg/m <sup>3</sup>
compressibility	1e-011 1/Pa
dilatation	0.000206
Reference length	1.03 m
Reference velocity	2.0 m/s
Reynold number	2.0396E+006
Flow model	Turbulent navier stokes

From table 3 showing the result of the cooling system in cylinder block. All the result are output of cooling system in cylinder block. For the output mass flow rate is 2452,4 g/s, fluid temperature after through the Engine block is 536,9 K and the wall temperature or cylinder block temperature is higher than fluid temperature is

567,1. And the heat transfer happen in between cooling fluid and the cylinder block wall is 52,41 KW. All this result will use to simulate the flow in 3D modeling of jacket cooling system.

TABLE 3.  
 OUTPUT DATA CYLINDER BLOCK

NO	Part Name	Block
1	Mass flow rate (g/s)	2452,4
2	Fluid temperature (K)	433.8
3	Wall Temperature (K)	468.2
4	Heat Transfer (kW)	59,68

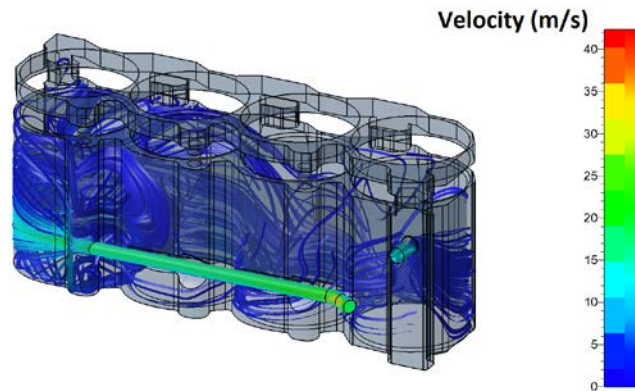

Figure. 5. velocity fluid flow in jacket cooling (1400 rpm)

The figure 5 show that the velocity is high when the fluid enters the jacket cooling system. the velocity is high because there is force by pump which make the velocity high when in the inlet area. When the fluid already in the jacket cooling, the velocity will decrease. There are some space in various area in jacket cooling system, in that area there are a fluid with the velocity is very low because of the turbulent flow. Flow in which the fluid undergoes irregular fluctuations, or mixing, in which the fluid moves in smooth paths or layer

The velocity in outlet is higher than velocity in the jacket cooling and it will same velocity as inlet because of continuity equation. In fluid dynamic, the continuity equation state that, in any steady state process, the rate at which mass enters a jacket cooling system is equal to the rate at which mass leaves the jacket cooling system.

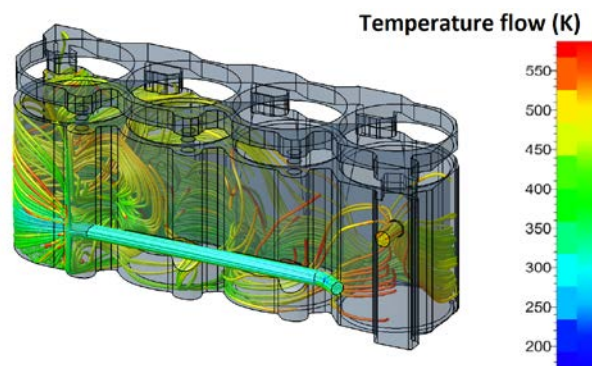

Figure. 6. temperature flow in jacket cooling (1400 rpm)

Figure 6 is the result of temperature flow in jacket cooling system. before fluid enters the jacket cooling, the temperature of the fluid is low around 300 – 350 K. When the fluid enters tha jacket cooling, it will be increase the temperature of the fluid flow. The temperature of the fluid increase because of the wall temperature. Heat treansfer will happen in jacket cooling system between wall temperature and fluid temperature. The fluid make absorb the high temperature in wall of

jacket cooling and make the fluid increase the temperature, it means the outlet temperature of fluid will be higher than before the fluid enters the jacket cooling system.

Table 4 is the input for jacket cooling system 3D simulation with engine speed 1800 rpm

TABLE 4.  
 INPUT 3D SIMULATION 1800 RPM

NO	Part Name	Block
1	Mass flow rate (g/s)	2452,4
2	Fluid temperature (K)	468.5
3	Wall Temperature (K)	501.6
4	Heat Transfer (kW)	59,68

Figure 7 is the result of the fluid flow jacket cooling system with 1800 rpm. The figure show that the velocity is high when the fluid enters the jacket cooling system. the velocity is high because there is force by pump

which make the velocity high when in the inlet area. The vector line is more than the lowest engine speed

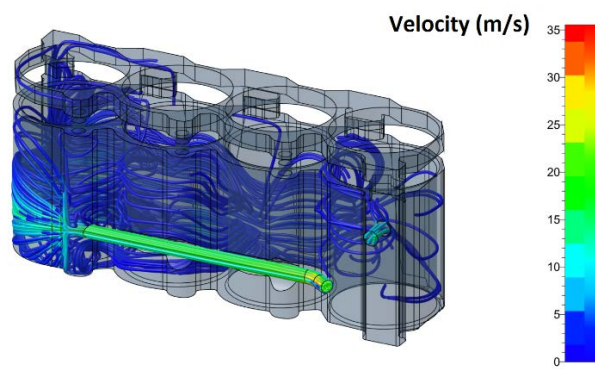

Figure 7. velocity fluid flow in jacket cooling (1800 rpm)

Figure 8 is the result of the flow temperature in jacket cooling system. the temperature is increasing when

trought the jacket cooling because of heat transfer in jacket cooling system

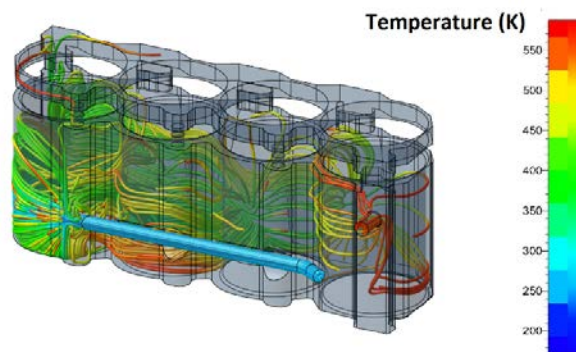

Figure 8. temperature flow in jacket cooling (1800 rpm)

Table 5 is the input for jacket cooling system 3D simulation with engine speed 2200 rpm

TABLE 5.  
INPUT FOR 3D SIMULATION 2200 RPM

NO	Part Name	Block
1	Mass flow rate (g/s)	2452,4
2	Fluid temperature (K)	536,9
3	Wall Temperature (K)	567,1
4	Heat Transfer (kW)	52,41

Figure 9 is the flow velocity of jacket cooling system when engine speed is 2200 rpm. The vector line of the simulation is more that the lowest engine speed. In the

first cylinder (from left), the vector line almost fill all in first cylinder because the velocity of fluid flow is high

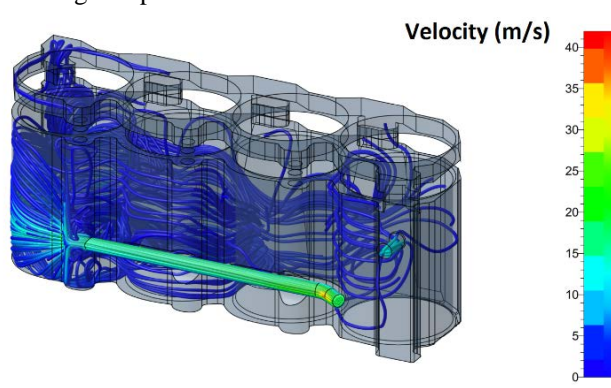

Figure 9. flow velocity with 2200 rpm

Figure 10 is the temperature flow of jacket cooling system when the engine speed reach the maximum rpm. The engine speed for this simulation is 2200 rpm. The

temperature is increasing after through the jacke cooling system.

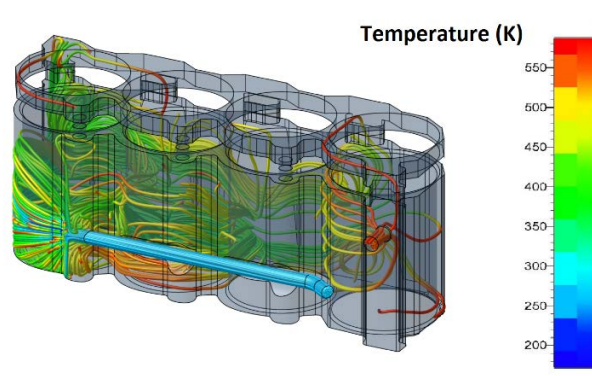

Figure. 10. temperatur flow with 2200

#### IV. CONCLUSION AND SUGGESTION

From the result of research analysis it was concluded that:

1. The simulation begin with the design of jacket cooling system. The design made based on cylinder block and cylinder head dimation. The design have an inlet and outlet to show the fluid when enters the jacket cooling until leaves the jacket. the data will be used in fluid flow jacket cooling system simulation are mass flow, temperature of fluid and wall temperature of jacket cooling and heat transfer. All the data will obtained by simulate the 1D modeling with 1D simulation software. The data will be required to show the fluid flow and the temperature flow in the jacket cooling system using numeca software
2. With the jacket cooling design in marine diesel engine 93 KW, the flow in jacket cooling system is good. But in this design there are much turbulent flow in jacket cooling system and it can make the efficiency of jacket cooling system is low. from the simulation, the highest engine speed of engine will increasing the velocity of fluid which enters the jacket cooling system beacause the cylinder block of engine need more fluid flow for cool down the cylinder block and the lowest engine speed will make the velocity is decreasing because the cylinder block temperature is lowest than cylinder block with highest engine speed.

The jacket cooling system design can use in marine diesel engine 93 KW with the same dimation, but the fluid flow in jacket cooling system will be better if the inlet and outlet be change the position. The inlet will be lower and the outtet will be higher, it will can make a diffrent fluid flow in jacket cooling system. it can be better if there are inlets and outlets at each cylinder, it means there are 4 inlets and 4 outlets. The flow will reach all the area of jacket cooling system

#### REFERENCES

- [1] Raharjo, J. "Design marine diesel using Reverse Engineering Method". Bachelor Thesis, Department of Marine Engineering, Faculty of Ocean Technology, Insatitut Teknologi Sepuluh Nopember, Surabaya, Indonesia, (2015)
- [2] A.M. Kriger, M.E. Diskin, M.E. Diskin, "Liquid Cooling of Automotive Engine", Mashinostroenie, Moscow, (1985).
- [3] U.S Department of Energy, Thermodynamic, Heat Transfer, and Fluid Flow, Volume 1-3, Washington, June 1992
- [4] J. H. Ferziger and M. Peric, Computational Methods for Fluid Dynamics. Springer, (1996).
- [5] Mohammadi A and Yag houbi, 2011, Two Phase Flow Simulation for Subcooled Nucleat Boiling Heat Transfer Calculation in Water Jacket of Diesel Engine, Vol 2, Spring (2011)
- [6] Mulemane, A., Soman, R. "CFD Based Complete Engine Cooling Jacket Development and Analysis", SAE 2007-01-4129.
- [7] Alexey Vdovin, 2010, Cooling performance simulations in GT-Suit, Chalmers Reproservice, Göteborg, Sweden 2010
- [8] R. Hemmatkhanloo, A. Mohammadi, Mostafa Varmazyar. "Research on modification of cooling passage for a 4-cylinder turbocharged SI engine with precise cooling view point". The Journal of Engine Research, Vol. 41 (Winter 2016), pp. 31-39.
- [9] R.S. Laramee, C. Garth, H. Doleisch, J. Schneider, H. Hauser, H. Hagen. "Visual Analysis and Exploration of Fluid Flow in a Cooling Jacket" <http://www.winslam.com/rlaramee/laramee/jacket/laramee05jacket.pdf> was download on February, 2017