



Evaluation of HFMI as a Life Extension Technique for Welded Bridge Details

Downloaded from: <https://research.chalmers.se>, 2021-08-31 18:58 UTC

Citation for the original published paper (version of record):

Edgren, M., Barsoum, Z., Åkerlind, K. et al (2019)

Evaluation of HFMI as a Life Extension Technique for Welded Bridge Details

Procedia Structural Integrity, 19: 73-80

<http://dx.doi.org/10.1016/j.prostr.2019.12.009>

N.B. When citing this work, cite the original published paper.

Fatigue Design 2019

Evaluation of HFMI as a Life Extension Technique for Welded Bridge Details

M. Edgren^{a,b,*}, Z. Barsoum^{a,c}, K. Åkerlind^a, M. Al-Emrani^c

^a*KTH Royal Institute of Technology, Teknikringen 08, Stockholm 10044, Sweden*

^b*DEKRA Industrial AB, Hemvärnsgatan 11B, Solna 17126, Sweden*

^c*Chalmers University of Technology, Chalmersplatsen 4, Gothenburg 41296, Sweden*

Abstract

In this current study, HFMI technique is used to study the possibility to extend the fatigue life of pre-fatigued flange gusset welds typically found in girder bridges. The results from the study are also compared with results found in the literature for other more conventional techniques for retrofitting, e.g. cut-outs. The study also aims to investigate if the IIW HFMI recommendations could be applied for existing steel structures and that equal fatigue strength improvement could be claimed for prefatigued structures. Furthermore, new recommendations for structural hot spot stress type B are suggested for HFMI treated welds, applicable to flange gusset welds. The results indicate that the HFMI could be used for welded bridge details rehabilitation as a competing technology with conventional cut-out. Furthermore, the results indicate that the IIW recommendations for HFMI fatigue strength improvement could also be applied for pre-fatigued welded details.

© 2019 The Authors. Published by Elsevier B.V.

Peer-review under responsibility of the Fatigue Design 2019 Organizers.

Keywords: Welded joints; fatigue; Life extension; improvement technique; HFMI;

* Corresponding author. Tel.: +46 70 300 3424.

E-mail address: edgren@kth.se

1. Introduction

The Swedish Transport Administration currently manages more than 16,000 road bridges and 4,100 railway bridges where about 50% of these bridges are older than 50 years. These bridges were designed for lower traffic loads and less traffic intensity than they were exposed to over the years. For road bridges, the latest increase in the permissible vehicle load from 65 to 74 tonnes will place great demands on both reinforcement and technical life enhancement. There are mainly two degradation mechanisms that are crucial for the life of steel bridges: fatigue and corrosion. The maintenance of bridges with respect to corrosion aspects is dealt with in an acceptable way, however fatigue has been a more difficult problem to manage, which require frequent repair and structural health monitoring. Hence the technical life of steel bridges is determined by its fatigue life. At present there is no established method, except for load reduction via reinforcement, which can be used to extend the life of a fatigued steel bridges. Neither the fatigue strength nor the already accumulated fatigue damage is improved or affected. Therefore, these methods are more suitable as temporary reinforcement measures or when repairing already cracked bridge elements. When the fatigue life of a bridge is reached, it is necessary either to replace the entire bridge or to replace critical elements and load-bearing systems. The International Institute of Welding (IIW) have recently published a comprehensive recommendation on retrofitting, repair of fatigue damaged steel structures (Miki (2009)). The recommendation summaries a large number of welded girder bridge repair cases over the years and the technologies related to these retrofitting tasks. Some of the most conventional repair and retrofitting techniques are; plate replacement and bolt connections, stop holes, crack removal and grinding, TIG dressing and damage cut out.

Since flange gusset is recognized to have very low fatigue resistance and subjected to high bending stress cycle, one of the most frequent methods used to improve fatigue strength is by enlarging the fillet radius by gas-cut and machine (drill)-cut. Since the gas-cut may introduce harmful tensile residual stress at the cut surface, application of hammer peening after the enlargement to introduce compressive residual stress is examined (Miki et al. (1998)). The local nature of fatigue damage in welded joints means that one can increase the fatigue strength of a welded joint by improving conditions at the weld toe, since fatigue cracks often starts at this location due to high stress concentration, high tensile residual stresses and weld defects (Barsoum (2011)). This can basically be accomplished through one, or a combination of, the following actions:

- Reduce the geometric stress concentration at the transition between the base and weld toe
- remove local imperfections along the weld (e.g. undercuts)
- Relax tensile welding residual stresses and - if possible - introduce compressive residual stresses in the area around the weld toe

In 2013 IIW published a collective recommendation for improving the fatigue strength of welded joints sensitive for weld toe cracking (Haagensen et al. (2013)). This gives detailed guidelines for procedures, quality assurance of treatment and expected fatigue strength improvement for; burr grinding, TIG dressing, hammer-and needle peening. However, recent studies have showed that these fatigue strength enhancements are slightly conservative and higher fatigue strength can be claimed for a successful treatment, particularly for hammer peening and TIG dressing (Marquis et al. (2013)), (Marquis et al. (2014)), (Yildirim (2015)).

High-frequency mechanical impact (HFMI) has emerged as a reliable, effective, and user-friendly method for post-weld fatigue strength improvement technique for welded structures. In 2016 IIW published recommendation for HFMI treatment for improving fatigue strength of welded joints (Marquis et al. (2016)). These recommendations give detailed guidelines on procedure, quality control and fatigue strength improvement for a large range of structural steels, 235 – 950 MPa in yield strength, with approximately 12.5 % increase in fatigue strength for each 200 MPa increase in yield strength. The beneficial effect is mainly because of the impacted energy per indentation. The impacted material is highly plastically deformed causing changes in the material microstructure and the local geometry as well as high compressive residual stresses, in the close region of the yield stress of the material.

Khurshid et al. studied the behavior of the compressive residual stresses induced by HFMI treatment under cyclic loading, constant-and variable amplitude loading, for different steel grades (Khurshid et al. (2014)). They observed that the compressive residual stresses are stable with minor relaxation throughout the fatigue life, where overloads contributed mostly to the relaxation.

Leitner et al. developed FE and analytical models to study the stability of compressive residual stresses under cyclic loading of welded joints. The models were validated with measurements and it was concluded that the cyclic

stability of the compressive residual stress occurs in the very first cycles and is stable thereafter (Leitner et al. (2017)). Leitner et al. studied the possibilities of using HFMI as a rehabilitation technique of pre-fatigued welded structures (Leitner et al. (2016)).

If the HFMI treatment is applied without previous grinding and re-welding of the weld toe, a maximum crack size in depth of 0.5 mm acts as conservative proposal for mild steel joints, the rehabilitation by HFMI leads to an improvement in fatigue strength both in the finite-life and high-cycle fatigue region. However, there are limited investigations on the capabilities of the HFMI technique to improve the fatigue strength of existing, pre-fatigued, steel structures. Furthermore, it is not fully investigated if the fatigue strength improvement recommended by IIW (Marquis et al. (2016)) could be applicable as rehabilitation fatigue strength curves for pre-fatigued welded joints in conjunction with HFMI treatment.

Fig. 1 illustrates a typical bridge section in a welded girder bridge. The different details are the most fatigue critical sections in the girder bridge; butt weld, transverse stiffener weld and flange gusset weld, numbered 1-3. In this current study, HFMI technique is used to study the possibility to extend the fatigue life of pre-fatigued flange gusset welds. The results from the study are also compared with results found in the literature for other more conventional techniques for retrofitting, e.g. cut-outs. The study also aims to investigate if the IIW HFMI recommendations (Marquis et al. (2016)) could be applied for existing steel structures and that equal fatigue strength improvement could be claimed for prefatigued structures. Furthermore, new recommendations for structural hot spot stress type B are suggested for HFMI treated welds, applicable to flange gusset welds.

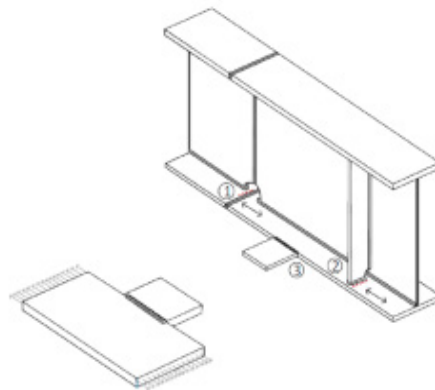

Fig. 1. A typical bridge section with three different corresponding structural weld details;

2. Welded detail and quality

2.1. Welded detail

In this study a low-grade steel (S355J2+N, $f_y = 355$ MPa) flange gusset specimen is investigated, see Fig 2, corresponding to Structural Detail No. 526 according to IIW recommendations for fatigue design of welded joints and components (Hobbacher (2009)).

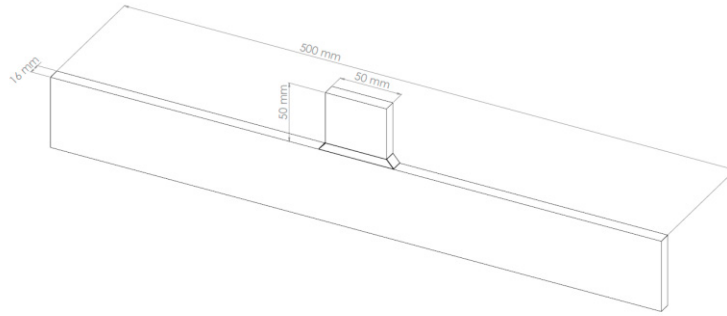

Fig. 2. Flange gusset plate;

The specimen is manually metallic arc welded using filler material with a diameter of 1.2 mm. The gusset plate is joint prepared with a 30-degree joint angle. Dual-pass welds are made, root and cap and extended in the corner where the gusset plate meets the main plate.

2.2. Weld and HFMI treatment quality

The weld of the specimen is tested with a weld quality control system developed by Stenberg et al (Stenberg et al. (2017)). The visual system is based on a laser line scanner which in combination with an actuator (linear or robot) builds up a high-resolution 3D surface of the weld bead, see Fig 3. The surface is discretized to profiles and each profile is verified according to SS-EN-ISO5817 based on geometric parameters e.g. undercut, weld toe angle and leg lengths for fillet welds. The Wintertia® system (Wintertia AB) also reports the weld toe radius which is an important geometric parameter for the fatigue property of the weld.

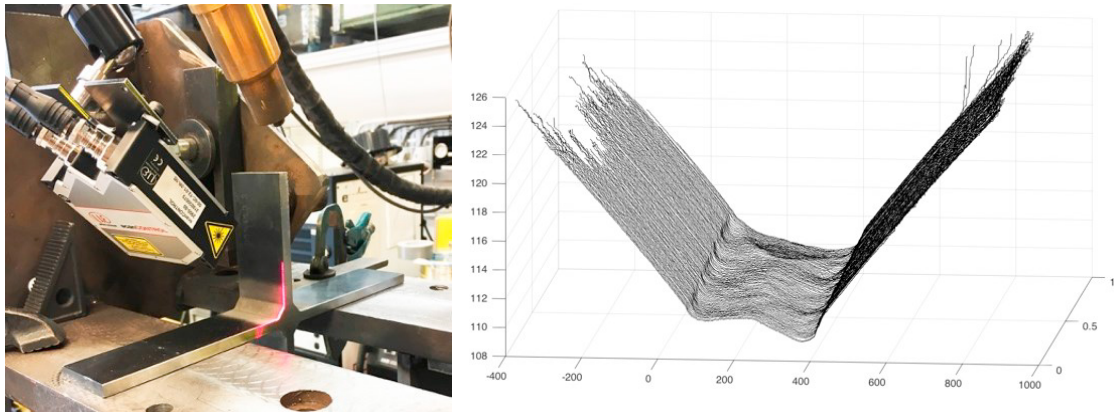

Fig. 3. Wintertia® robot weld scanner and result of weld profile;

Based on the weld profile measurement data a percentage of the analyzed weld that corresponds to a certain weld class, being classes D, C and B according to SS-EN-ISO5817 is returned. For the specimen studied herein, the weld toe at the main plate is the most critical position from fatigue point of view. Thus, the highest percentage agreement in weld toe radii on the main plate is used to determine the weld quality level. Most of the specimens corresponds to weld quality B90. It is concluded that the evaluated specimens are suited for HFMI treatment according to the IIW

recommendations (Marquis et al. (2016)), which recommends weld quality B to be successfully treated with HFMI. Furthermore, the treatment has been quality assured resulting in a HFMI groove of 0.2-0.3 mm, in accordance with (Marquis et al. (2016)), and the residual stresses are compressive (200 MPa).

3. Fatigue testing and Non-destructive testing

One test series was HFMI treated before fatigue loading and one was prefatigued with 90% of the fatigue life based on FAT50 (considering mean strength). This approach was implemented in order to simulate a life extension of welded bridge detail at a late stage of its service life. The specimens were tested at constant amplitude between 100 and 200 MPa at a stress ratio 0.1. Also, a series in as-welded condition was tested.

3.1. Cut out

Miki et al carried out comprehensive fatigue testing program on cut-outs as retrofitting technique in conjunction with additional post weld improvement, e.g. hammer peening (Miki et al. (1998)). Fig. 4 illustrates the procedure of cut out in order to improve flange gusset details and Table 1 presents the different improvement methods used by Miki et al (Miki et al. (1998)).

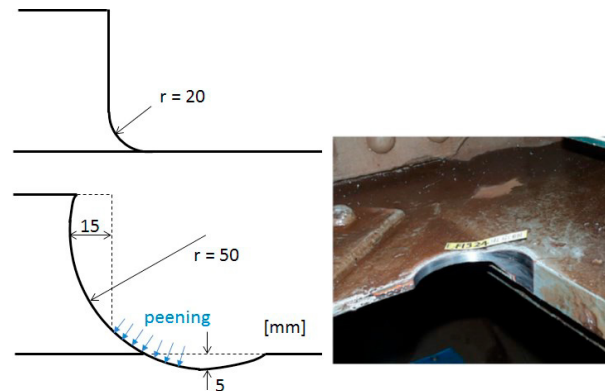

Fig. 4. Improving flange gusset detail with cut-out;

Table 1. Improvement techniques according to Miki et al. (Miki et al. (1998))

Type	Method
A	As-welded
B	r = 20 mm (+ Grinding)
C	r = 50 mm (Drill-cut)
D	r = 50 mm (Gas cut)
E	r = 50 mm (Gas cut + hammer peening)

Fig. 5 shows the fatigue test results from Miki et al (Miki et al. (1998)) in comparison with fatigue test results presented in this study for AW, HFMI and life extension using HFMI at different stages of the fatigue life. It is observed that the As-welded fatigue test results in the current study perform better than Miki et al (Miki et al. (1998)), mainly due to better weld quality (B90 according to ISO 5817), which was confirmed previously. The HFMI treated specimens proves to have similar fatigue performance as the different type of improvement, B-E. It is observed that the prefatigued (90%) and HFMI treated specimens have better fatigue performance in comparison to the conventional retrofitting type B-D, and superior fatigue performance in comparison to Type E; gas-cut and

hammer peening. Hence, this demonstrates that HFMI could successfully be used as retrofitting and life extending competitive technique.

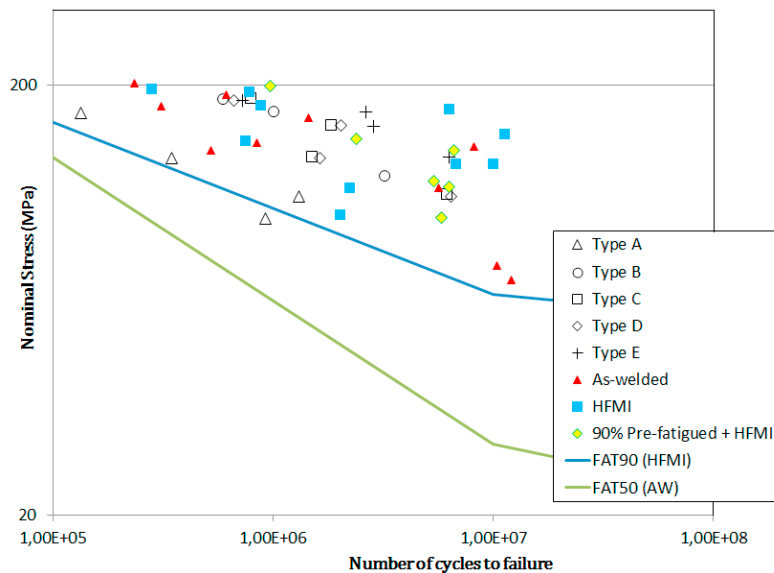

Fig. 5. Comparison with fatigue test results from cut-out (Miki et al. (1998));

3.2. Non-destructive testing

In order to determine any damages/fracture to the prefatigued samples ($N_f = 90\%$) prior HFMI rehabilitation different NDT methods were evaluated. Magnetic Testing, Magnetic Testing with fluorescent fluid and black light, see Fig. 6, Penetrant Testing and Radiographic Testing were used. All the methods showed inconclusive results, i.e. some methods showed linear indications in the vicinity of the weld toe, but it was not possible to distinguish them from possible artefacts created from the shape of the weld. Ultra-sonic Testing was not evaluated in this study.

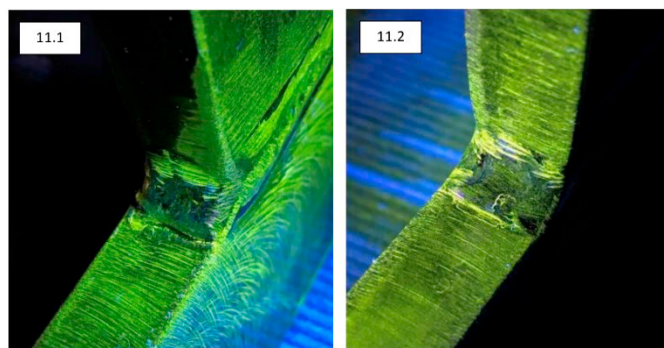

Fig. 6. Magnetic testing with fluorescent fluid and black light;

3.3. Strain amplitude drop and crack growth monitoring

In earlier work by Leitner and Barsoum (Leitner et al. (2016)) it was shown that strain drop could be used as an indication of crack depth. The study also showed that the crack depth was of great importance for the life extending effect of HFMI, due to HFMI being a method with limited sub surface impact. In this study a qualitative strain drop

monitoring was performed. Additional test results, not presented in this study, indicate quite significant difference in crack initiation time, i.e. compared number of cycles at a defined strain drop (typically 5%). However, the specimens are well above the calculated life using the nominal stress approach. Fig. 6 shows the strain-drop (in %) vs. number of cycles to failure. $N_{90\%}@FAT50$ represents the calculated 90 % fatigue life corresponding to FAT 50 (mean strength for structural detail No. 526, as welded). $N_{100\%}@FAT90$ represents the calculated 100 % fatigue life (failure) corresponding to FAT 90 (mean strength for HFMI treated weld with $f_y = 355$ MPa).

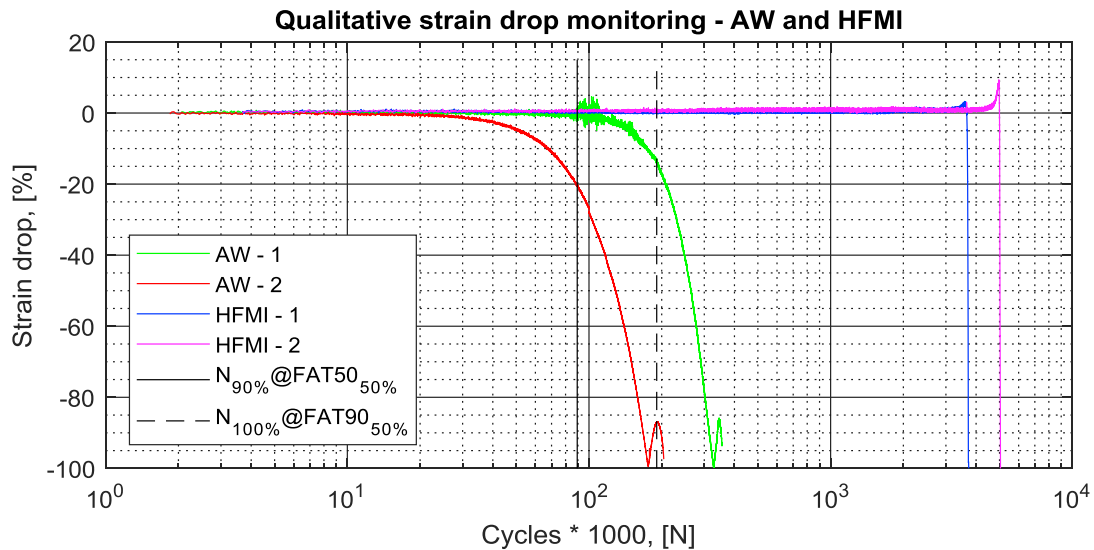

Fig. 7. % Strain-drop vs. number of cycles for aswelded (red and green) and HFMI treated (blue and magenta);

It is observed that the first as welded specimen (red curve) is at the limit in order to have a successful HFMI treatment in terms crack depth according to (Leitner et al. (2016)).

4. Discussion and concluding remarks

In this current study, HFMI technique is used to study the possibility to extend the fatigue life of pre-fatigued flange gusset welds typically found in girder bridges. The results from the study are also compared with results found in the literature for other more conventional techniques for retrofitting, e.g. cut-outs. During the weld quality assurance of the as-welded specimens, it was observed that most of the welds were in corresponds to weld quality B90 according to ISO 5817, indicating higher weld quality which also could be observed in the high fatigue strength performance for the as-welded samples. Some of these test results had similar performance as the HFMI treated samples. Comparing the HFMI treated fatigue samples with other competing retrofitting methods, e.g. hammer peening and cut out (Miki et al. (1998)) reveals that the results in this current study are comparable with conventional retrofitting. However, one of the great benefits with HFMI retrofitting is that it does not require additional pre-treatment operation, as in comparison with the other techniques, see Fig 5.

Current NDT methods have a limitation to estimate the crack depth. In this study several of these methods have been tested. However, the results are inconclusive, and the methods used are not capable to characterize crack size and depth. Therefore, strain-drop measurements were adopted as qualitative approach to find indication of crack depth and size, as shown by Leitner et al (Leitner et al. (2016)), due to the strain-drop over the fatigue life. Different details have different shapes of strain drop curves. Curves also differ in terms of crack initiation time. To make results comparable between different retrofitting methods and/or specimen types it is proposed to use strain drop level as criterion for setting in the evaluated method. It is also proposed that further studies should focus on development of strain-drop criteria for crack size and depth detection.

Further analysis of the fatigue test results assessed by the structural hot spot method was carried out in order to validate an HFMI fatigue strength hot spot type B (Hobbacher (2009)). IIW recommendations on HFMI give fatigue stress recommendations for hot spot, however the recommendations are only validated for certain types of hot spot. This study indicates that recommendation for hot spot type A can be used also for type B.

References

- Miki, C., Retrofitting engineering for fatigue damaged steel structures, International Institute of Welding, Doc.IIW-XIII-2284r1-09, 2009
- Miki, C., Sugimoto, I., Kaji, H., Negishi, H. and Ito, Y., 1998. A Study on fatigue strength improvement of flange gusset in existing steel railway bridges. *Doboku Gakkai Ronbunshu*, 1998(584), pp.67-77.
- Barsoum, Z., 2011. Fatigue design of welded structures—some aspects of weld quality and residual stresses. *Welding in the World*, 55(11-12), pp.2-11.
- Haagensen, P.J. and Maddox, S.J., 2013. IIW Recommendations on methods for improving the fatigue strength of welded joints: IIW-2142-110. Woodhead publishing.
- Marquis G., E. Mikkola, H. Yildirim and Barsoum Z., 2013. Fatigue Strength Improvement of Steel Structures by HFMI: Proposed Fatigue Assessment Guidelines, *Welding in the World*, No. 57, pp. 803-822.
- Marquis G. and Barsoum Z., 2014. Fatigue Strength Improvement of Steel Structures by HFMI: Proposed Procedures and Quality Assurance Guidelines, *Welding in the World*, No. 58, pp. 19-28.
- Yıldırım, H.C., 2015. Review of fatigue data for welds improved by tungsten inert gas dressing. *International Journal of Fatigue*, 79, pp.36-45.
- Marquis G.B. and Barsoum Z., 2016. IIW Recommendations for the HFMI Treatment - For Improving the Fatigue Strength of Welded Joints, ISBN 978-981-10-2503-7, Springer.
- Khurshid, M., Barsoum, Z. and Marquis, G., 2014. Behavior of compressive residual stresses in high strength steel welds induced by high frequency mechanical impact treatment. *Journal of Pressure Vessel Technology*, 136(4), p.041404.
- Leitner, M., Khurshid, M. and Barsoum, Z., 2017. Stability of high frequency mechanical impact (HFMI) post-treatment induced residual stress states under cyclic loading of welded steel joints. *Engineering Structures*, 143, pp.589-602.
- Leitner, M., Barsoum, Z. and Schäfers, F., 2016. Crack propagation analysis and rehabilitation by HFMI of pre-fatigued welded structures. *Welding in the World*, 60(3), pp.581-592.
- Hobbacher, A., 2009. Recommendations for fatigue design of welded joints and components. New York: Welding Research Council.
- Stenberg, T., Barsoum, Z., Åstrand, E., Öberg, A.E., Schneider, C. and Hedegård, J., 2017. Quality control and assurance in fabrication of welded structures subjected to fatigue loading. *Welding in the World*, 61(5), pp.1003-1015.
- Winteria, Nordenholm 104, 824 93 Hudiksvall, Sweden