

Viral metagenomics, protein structure, and reverse genetics: Key strategies for investigating coronaviruses

Bryan A. Johnson^a, Rachel L. Graham^b, Vineet D. Menachery^{a,*}

^a Department of Microbiology and Immunology, University of Texas Medical Branch, Galveston, TX, USA

^b Department of Epidemiology, University of North Carolina at Chapel Hill, Chapel Hill, NC, USA

A B S T R A C T

Viral metagenomics, modeling of protein structure, and manipulation of viral genetics are key approaches that have laid the foundations of our understanding of coronavirus biology. In this review, we discuss the major advances each method has provided and discuss how future studies should leverage these strategies synergistically to answer novel questions.

1. Introduction

The Severe Acute Respiratory Syndrome (SARS) epidemic first emerged in southern China in late 2002 and rapidly spread world-wide, causing 8096 confirmed cases in 27 countries and resulting in 774 deaths (World Health Organization, 2004). Defined as a novel coronavirus (CoV) (Drosten et al., 2003; Ksiazek et al., 2003; Peiris et al., 2003a; Rota et al., 2003), SARS-CoV was generally agreed to have originated in bats and highlighted the risk posed by viruses emerging from zoonotic sources (Guan et al., 2003; Lau et al., 2005; Li et al., 2005b; Tang et al., 2006; Tu et al., 2004). A decade later, Middle East Respiratory Syndrome CoV (MERS-CoV) was identified as the causative agent of another ongoing outbreak (Zaki et al., 2012). In the five years since, significant progress has been made in understanding the origins, biology, and emergence potential of CoVs. These studies have been aided by advancements in three critical research areas: viral metagenomics, structural modeling studies, and reverse genetics. In this review, we detail novel insights recently defined by advances in each approach and discuss their impacts on our understanding of CoV infection and emergence. We also consider how these strategies can be integrated to better prepare for the next emergent CoV strain.

2. Exploring an unknown frontier

Viral metagenomics has greatly expanded the scope and understanding of CoVs. Before 2002, the CoV family consisted of a relatively modest number of viruses infecting the airway or the fecal-oral tracts. With the only known human CoV strains causing mild disease, the family had not been considered a significant threat to human public health. In 2002, SARS initially presented itself as an atypical

pneumonia for which no known causal agent could be determined (Peiris et al., 2003b). Eventually, the novel CoV was isolated from infected patients and sequenced, demonstrating SARS to be caused by a genetically distinct CoV of unknown origin (Peiris et al., 2003a; Rota et al., 2003). With the earliest cases of SARS occurring in food service workers handling exotic animals, initial studies focused on surveying animals in live markets for the presence of SARS-CoV progenitors using traditional viral discovery methods, including seropositivity studies, isolation in culture, visualization of virions using electron microscopy (Guan et al., 2003; Tu et al., 2004). Such viral discovery efforts led to the identification of a SARS-CoV strain in a Himalayan palm civet that shared 99.8% nucleotide identity with the epidemic strain (Guan et al., 2003). Later, the observation that neither farmed nor wild civets harbored SARS antibodies outside of live animal markets led to the investigation of other zoonotic sources for SARS-CoV (Poon et al., 2005; Tu et al., 2004). Studies quickly identified SARS progenitors circulating in bats belonging to the *Rhinolophus* genus (commonly referred to as horseshoe bats). Full genome comparisons determined that these progenitor strains had similar genome organization to and a high nucleotide sequence identity (88–92%) with SARS-CoV, suggesting that the epidemic strain emerged from these bat CoV populations (Lau et al., 2005; Li et al., 2005b; Ren et al., 2006; Tang et al., 2006). Together, these studies established the classic model of SARS-CoV emergence, whereby civets initially infected with SARS-CoV served as intermediate hosts, leading to the generation of an adapted strain capable of human infection.

The discovery of the progenitor SARS-like CoV strains circulating in Chinese bat populations led to a global effort to identify and define the phylogenetic relationships of the Coronaviridae family. Over the past 15 years, dozens of animal populations have been surveyed, and the

* Correspondence to: University of Texas Medical Branch, 301 University Blvd., Route 610, Galveston, TX 77555-0610, USA.
E-mail address: Vimenach@utmb.edu (V.D. Menachery).

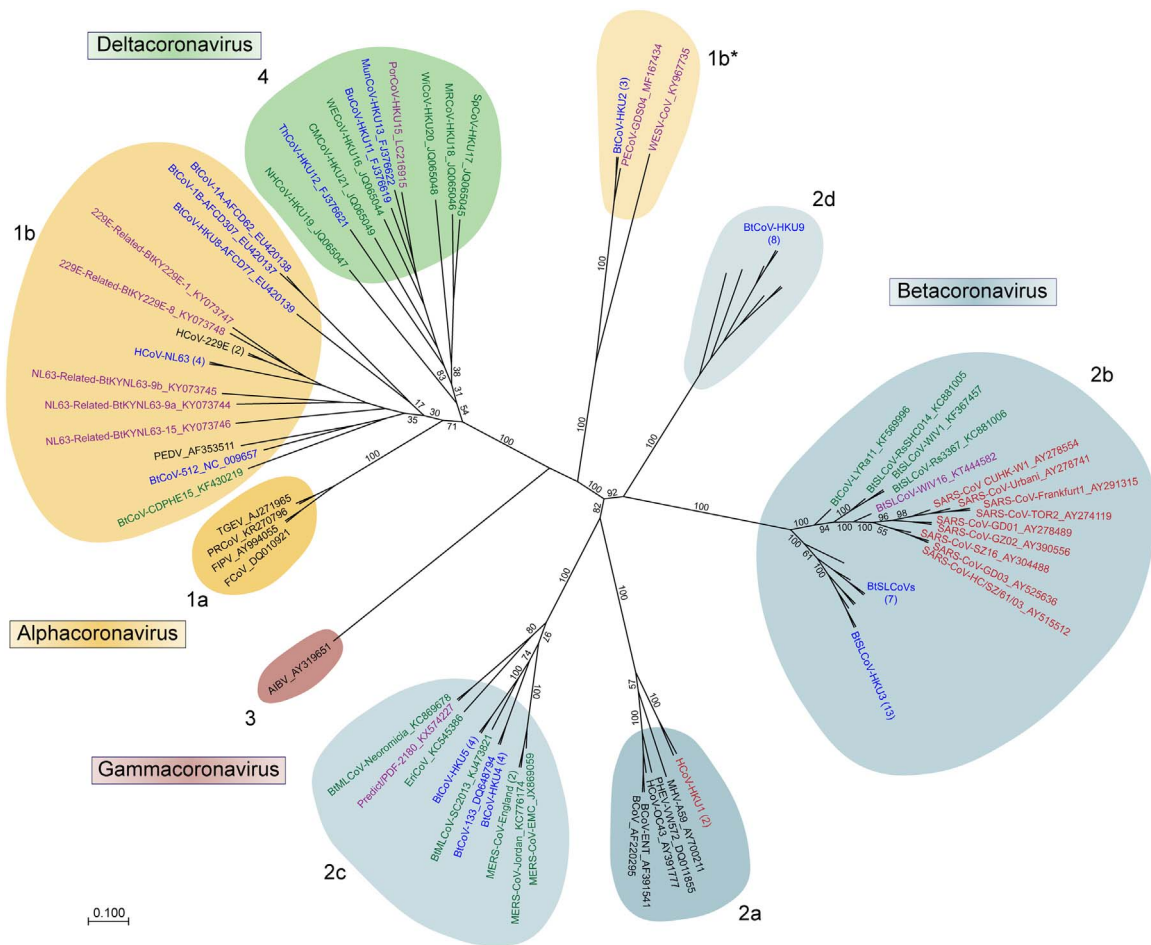

Fig. 1. *The expanding phylogeny of coronaviruses.* The Spike protein sequences of 83 coronaviruses were aligned and phylogenetically compared. The four coronavirus genera are grouped in shades of orange (Alphacoronavirus), blue (Betacoronavirus), red (Gammacoronavirus), and green (Deltacoronavirus). Classic subgroup designations (1a-b, 2a-d, 3, and 4) are also shown. Sequences designated as 1b* group with 1b viruses in proteins other than Spike. Individual viral species and strains are colored based on the original publication dates of their sequences: black (pre-2002), red (2002–2005), blue (2006–2011), green (2012–2014), and purple (2015–2017). Sequences were aligned using the MUSCLE package in Geneious R9. The tree was constructed using the neighbor-joining method based on the multiple sequence alignment, also in Geneious R9. Numbers in parentheses following virus species names indicate the number of sequences represented at that tree position. The radial phylogram was visualized and rendered for publication using CLC Sequence Viewer 7 and Adobe Illustrator CC 2017.

full-length genomes of numerous novel CoVs have been identified, greatly expanding the CoV family tree (Drexler et al., 2014). In contrast to the identification of SARS-CoV which relied on traditional discovery methods, the expansion of the CoV family tree has largely occurred through viral metagenomics, that is the through the direct examination of CoV genetic material obtained from environmental samples (Edwards and Rohwer, 2005; Simmonds et al., 2017). Many of these studies have relied on PCR based assays targeting conserved CoV sequences such as the RdRp gene (Drexler et al., 2014); the advent of inexpensive high-throughput deep sequencing methods has and will likely increasingly be exploited to study CoV populations (Alagaili et al., 2014; Anthony et al., 2013; Briese et al., 2014; Cotten et al., 2013a, 2013b, 2014; Donaldson et al., 2010). Currently, the Coronaviridae family is divided into 4 unique clades designated the Alpha-, Beta-, Gamma-, and Deltacoronaviruses (referred to hereafter by their historical designation as Groups 1–4, respectively) (Fig. 1) and include viruses known to infect humans, bats, other mammals, and several avian species. Among these, only CoVs designated in black were identified prior to the emergence of SARS-CoV. During the outbreak (2002–2005, red) and its immediate aftermath (2006–2011, green), a number of SARS-CoV-related and progenitor strains were identified and formed the core of the new group 2b branch. Similarly, identification of novel bat CoV sequences, including HKU4, HKU5, and HKU9-CoVs, populated newly formed groups. Likewise, the discovery of both HCoV-NL63 and HCoV-HKU1, which cause minor diseases in humans,

expanded upon CoV groups that already existed. Together, viral metagenomic studies in the wake of the SARS-CoV epidemic provided the first robust look into the existing CoV phylogeny and provided a framework for understanding the sources of CoV emergence.

This expanded phylogeny born from metagenomic studies of SARS-CoVs allowed for the rapid identification of the MERS-CoV as a group 2C CoV. Similar in sequence to HKU4 and HKU5-CoV, this novel human CoV was quickly distinguished from SARS-CoV; HKU4 and HKU5 were used as reagents to verify and characterize the new strain (Agnihotram et al., 2014a, 2014b). Further study led to the determination that HKU4, but not HKU5, could bind the MERS-CoV receptor, human dipeptidyl peptidase 4 (DPP4) (Wang et al., 2014). Just as SARS-CoV infection was traced to food service workers handling exotic animals, the observation that many MERS patients had been in contact with dromedary camels led to the search for MERS-CoV progenitors in camel populations (Azhar et al., 2014; Reusken et al., 2013). Camel herds throughout the Middle East were found to have MERS-CoV neutralizing antibodies and to harbor CoVs with nearly identical sequence to MERS-CoV (Azhar et al., 2014; Haagmans et al., 2014; Hemida et al., 2014; Reusken et al., 2013). Examination of historical serum samples suggested that MERS-CoV had been present in dromedaries since the 1980s and likely originated in Eastern Africa, traveling to Saudi Arabia via the camel trade (Muller et al., 2014). Together, the emergence of MERS-CoV highlighted the utility of expanding the CoV phylogeny through viral metagenomic studies.

While a number of studies had provided evidence for SARS-CoV's origin in bats, viral metagenomic surveys continued to add detail to the CoV tree. Despite having high sequence identity, potential SARS-CoV progenitors, such as HKU3, had < 70% amino acid identity within the S1 domain of the spike (S) protein (Lau et al., 2005; Li et al., 2005b; Ren et al., 2006; Tang et al., 2006) and could not bind either the civet or the human receptor, angiotensin-converting enzyme 2 (ACE2) (Lu et al., 2015; Ren et al., 2008). However, recent surveys in East Asia further expanded the CoV tree and identified several new group 2B CoVs with higher sequence identity to SARS-CoV S1. Four such virus sequence clusters have been identified: SHC014, LYRa11, WIV1, and WIV16, with 82.4%, 84.4%, 86.5%, and 95.4% amino acid identity with SARS-CoV S1, respectively (Ge et al., 2013; He et al., 2014; Yang et al., 2015). Importantly, three CoVs (SHC014, WIV1, and WIV16) have been shown experimentally to bind civet and human ACE2, suggesting that the epidemic strain SARS-CoV may have emerged from one of the quasi-species pools in the SARS-like CoV population (Ge et al., 2013; Yang et al., 2015). Similarly, more distantly related MERS-like CoVs have been found in bats throughout Africa, which possibly spread MERS-CoV progenitor virus(es) to camels in the region (Annan et al., 2013; Corman et al., 2014; Ithete et al., 2013). Two recent studies discovered the MERS-like CoVs NeoCoV and PREDICT/PDF-2180; each share > 85% nucleotide identity with MERS-CoV (Anthony et al., 2017; Corman et al., 2014) but have low sequence identity within MERS S1. Neither virus has been shown to utilize human DPP4 as a receptor, suggesting that they are not likely to emerge in humans. Even the origins of other human CoVs have recently been linked to bats; several CoV sequences were isolated from Kenyan bats and found to be closely related to HCoV-NL63 and HCoV-229E (Tao et al., 2017). Together, the continuation of viral metagenomic surveys provides a critical resource to quickly place novel strains and to define the origins of emergent viruses.

Since the emergence of SARS-CoV in 2002, viral metagenomics has provided an indispensable tool for the study of CoVs. Examinations of CoVs currently circulating in animal populations using culture independent sequencing techniques have allowed the field to trace the zoonotic origins of human CoVs to progenitor strains circulating in bats, providing insights into their emergence. Viral metagenomics has also greatly expanded our understanding of the diversity of the Coronaviridae family exemplified by the rapid classification of MERS-CoV within the existing group 2C clade. This designation permitted application of reagents against similar group 2C CoVs and had implications for characterization and treatment. Importantly, the existence of SARS like- and MERS like-CoVs circulating in zoonotic populations indicates a continued threat for the emergence and reemergence of CoVs. Using viral metagenomic techniques, surveillance can possibly identify and help predict the next emergent CoV strains.

3. Coronavirus spike structure: examining host tropism and epitope discovery

Studying protein structure has long been useful for understanding biological functions and developing therapeutics against emergent viruses, including influenza, Ebola, and Zika (Kang et al., 2017; Sapphire, 2013; Wu and Wilson, 2017). Notably, CoV research pioneered these types of studies in the context of an emerging virus outbreak, with structural models of the SARS-CoV Spike (S) protein providing insight into its transition to new hosts and its neutralization (Li, 2013; Lu et al., 2015). Recently, advances in structural biology and cryo-electron microscopy (cryo-EM) have permitted the recovery of CoV S proteins in their trimeric conformation (Kirchdoerfer et al., 2016; Pallesen et al., 2017; Walls et al., 2016a, 2016b; Yuan et al., 2017). The resulting efforts have not only improved our understanding of CoV biology but have also opened novel avenues for therapeutic treatments.

Following the original SARS-CoV epidemic, structural studies of the S protein provided insights into viral emergence and avenues to

therapeutic treatment. The CoV S protein is subdivided into an S1 domain, primarily responsible for receptor binding, and an S2 domain, which is responsible for the fusion of the viral and cellular membranes (Lu et al., 2015). In 2005, the crystal structure of the SARS-CoV receptor-binding domain (RBD) bound to human ACE2 indicated the presence of two subdomains, a core domain and the receptor-binding motif (RBM). Interacting with the N-terminal lobe of human ACE2, 14 RBM residues interact with 18 residues on human ACE2 to promote binding (Li et al., 2005a). Subsequent studies demonstrated that the primary barriers to host transition are differences in ACE2 sequences between species, necessitating changes in both topology and charge within the RBM (Li, 2008; Li et al., 2005c; Qu et al., 2005; Wu et al., 2012). Importantly, inefficient binding to both bat and mouse ACE2 by the epidemic SARS-CoV strains suggested that mutations were required for emergence (Frieman et al., 2012; Hou et al., 2010; Li, 2013; Roberts et al., 2007). Aided by the solved SARS-CoV S structure, epitope mapping of previously known SARS-CoV monoclonal neutralizing antibodies (mAbs) revealed that they bound primarily to the RBD, likely disrupting interaction with ACE2 (Cao et al., 2010; He et al., 2006, 2005b; Lu et al., 2004). In concordance, vaccine experiments with the SARS-CoV RBD induced neutralizing antibodies and protected against viral challenge (Du et al., 2007; He et al., 2005a, 2004; Zakhartchouk et al., 2007). In addition, mAbs targeting the RBD were also developed for prophylaxis; however, these mAbs were susceptible to escape mutations and lacked neutralization capacity against zoonotic SARS-CoV strains, thus limiting their value (Rockx et al., 2008, 2010; Sui et al., 2014). Coupled with the identification of additional SARS like-CoVs circulating in bat populations (Lau et al., 2005; Li et al., 2005b; Ren et al., 2008; Tang et al., 2006), the initial therapeutics developed to target the SARS-CoV RBD are unlikely to protect against newly emergent infections. However, these structural studies have provided important insights that have informed both studies of CoV emergence and therapeutic treatments against future emergent strains.

As was the case for viral metagenomics, structural studies examining SARS-CoV S provided a blueprint for investigations into the MERS-CoV S. The MERS-CoV RBD was rapidly identified, and its crystal structure was solved (Chen et al., 2013; Lu et al., 2013; Wang et al., 2013). The MERS-CoV RBD can also be divided into two subdomains: an RBM that binds the MERS-CoV receptor, DPP4, and a core domain with remarkable structural similarity to the SARS-CoV core domain. Eighteen amino acids within the RBM interact with 13 residues on DPP4 to promote binding (Lu et al., 2013; Wang et al., 2013). While differences in host sequences are again a barrier, DPP4 is relatively conserved among mammals (Barlan et al., 2014; Falzarano et al., 2014; Müller et al., 2012; Raj et al., 2014; van Doremalen et al., 2014). Common small animal models are a notable exception, with mice, rats, hamsters, and ferrets all encoding DPP4 proteins that cannot support infection, constituting a significant barrier to MERS-CoV research (Barlan et al., 2014; Coleman et al., 2014; de Wit et al., 2013; van Doremalen et al., 2014). Like SARS-CoV, the MERS-CoV RBD is also a strong immunogen; several vaccine studies have demonstrated its potential to induce neutralizing antibodies (Du et al., 2013a, 2013b; Mou et al., 2013). Together, these observations illustrate how structural prediction can be utilized for the development of vaccines and neutralizing antibodies.

Recently, advances in structural studies have produced a wealth of new CoV S structures (Kirchdoerfer et al., 2016; Pallesen et al., 2017; Walls et al., 2016a, 2016b; Yuan et al., 2017). While previous efforts had been made to explore CoV S proteins, these studies had elucidated only portions of S, including the post-fusion core and RBDs bound to receptors. While cryo-EM studies of SARS-CoV virions provided insights into the S glycoprotein, the lack of high-resolution CoV S trimer structures had limited progress in understanding entry and infection (Beniac et al., 2007; Neuman et al., 2006). Several groups recently overcame this barrier by fusing trimerization motifs into the CoV S (Kirchdoerfer et al., 2016; Pallesen et al., 2017; Walls et al., 2016a,

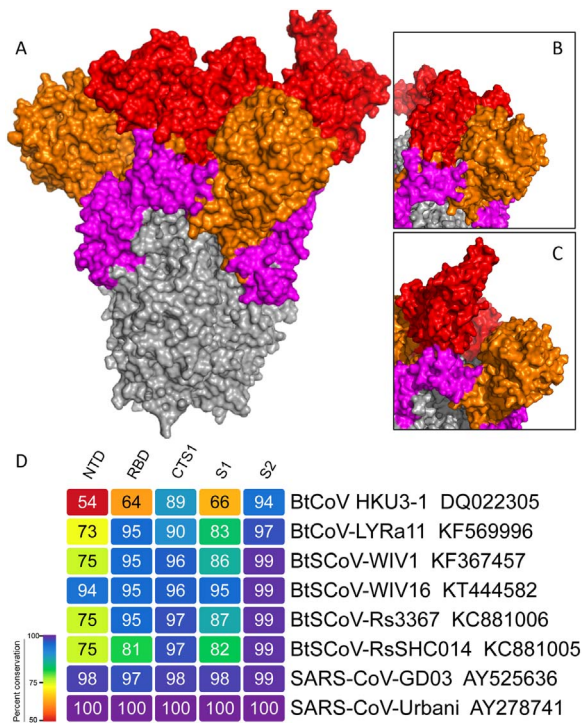

Fig. 2. Coronavirus trimer, a structure providing new insights. A) Overall structure of the SARS-CoV Spike ectodomain trimer as previously described (Yuan et al., 2017) was subdivided into the N-terminal domain (NTD, orange), receptor-binding domain (RBD, red), C-terminal to S1 cleavage (CTS1, magenta), and entire S2 domain (gray). B & C) Two previously predicted conformational states of the SARS RBD regions with the B) “lying” conformation and C) “standing” conformation. D) Spike protein sequences of the indicated viruses were aligned according to the bounds of the NTD, RBD, CTS1, S1, and S2. Sequence identities were extracted from the alignments, and a heatmap of sequence identity using SARS-CoV-Urbani as the reference sequence was constructed using EvolView (www.evolgenius.info/evolview). The heatmap was further rendered and edited in Adobe Illustrator CC 2017.

2016b; Yuan et al., 2017); the resulting chimeric proteins had increased stability, permitting the first characterizations of the CoV S in trimeric form. These initial studies provided novel insights into S proteolytic cleavage, viral fusion/entry, and conservation with other viral entry proteins. Subsequently, these studies spurred a wealth of new data and analysis.

Solving of the CoV S trimer provides a model upon which to base new hypotheses and analyses. The initial SARS-CoV S trimer structure indicated that the position of the SARS-CoV RBD within the S trimer may be dynamic, with the RBD shuffling between an exposed “standing” state and a “lying” conformation, where the RBD is buried between N-terminal domains within the trimer (Yuan et al., 2017) (Fig. 2). With receptor binding predicted to occur only in the “standing” position, neutralizing antibodies that bind the N-terminal domain (NTD) and prevent conformational switching may prove uniquely effective; however, a lack of conservation across the S1 NTD of group 2B viruses suggests this domain may be a poor target (Fig. 2D). In contrast, the structure of the S trimer suggested that the SARS-CoV fusion peptide (FP) and heptad repeat 1 (HR1) regions of S2 are exposed at the surface of the S trimer, indicating the opportunity to identify neutralization epitopes on a highly conserved region of the S protein (Yuan et al., 2017). The MERS-CoV S trimer was also solved recently by two separate groups. Like SARS-CoV, the MERS-CoV RBD also alternates between standing and lying states and has exposed residues in the FP and HR1 domains in S2 (Pallesen et al., 2017; Yuan et al., 2017). Importantly, a neutralizing antibody targeting the S2 region was thoroughly characterized and has potential as a prophylaxis agent (Pallesen et al., 2017). In addition, studies examining the HCoV-NL63 S trimer suggest that CoVs may utilize glycosylation to prevent recognition of

immunogenic epitopes by the host (Walls et al., 2016b). With similar glycosylation sites found on the SARS and MERS-CoV S trimers, these structural studies highlight areas on the S protein where antibody binding may be inhibited through glycan shielding (Yuan et al., 2017). Together, these structural data provide critical insights for the development of therapeutics against both current and potentially emergent CoVs.

Overall, structural studies examining CoV S glycoproteins have provided invaluable insights into both protein function and therapeutic design. The structures of the SARS- and MERS-CoV RBDs defined key correlates impacting host tropism and immunogenic features for vaccine and therapeutic studies. Moving forward, the solution of the trimeric forms of CoV S proteins creates an opportunity to better understand and model viral entry and fusion. Importantly, observations of S topology and glycosylation can be exploited in the development of universal therapeutics and vaccines. Together, the application of findings from structural studies has the potential to help identify, mitigate, or potentially prevent the next CoV outbreak.

3.1. Deriving insights by manipulating viral genetics

The use of reverse genetic systems (RGSs) to produce infectious particles and manipulate the genetic composition of the virus is an indispensable tool in virology (Perez, 2017). For CoVs, several systems have been developed (Almazán et al., 2014) and used to assess CoV protein function, design therapeutics, and evaluate the emergence potential of novel CoVs. Together, these RGS platforms have been key in characterizing and understanding CoVs infection in the context of recent outbreaks.

For many years, several barriers, including CoVs’ large size (~30 Kb) and the existence of toxic elements within the genome promoted genetic instability, limiting the development of CoV RGSs. While several other robust systems exist (Almazán et al., 2014), our laboratories have primarily utilized a sub-cloning strategy originally developed for transmissible gastroenteritis virus (TGEV) and subsequently deployed for other CoVs, including SARS-CoV and MERS-CoV (Beall et al., 2016; Becker et al., 2008; Scobey et al., 2013; Yount et al., 2000, 2003, 2002). Briefly, the full-length CoV genome is divided into cDNAs and cloned into separate plasmids with class IIG or IIS restriction sites added to each end. Fragments are then directionally assembled into a full-length cDNA CoV genome by *in vitro* ligation. The CoV genome is subsequently transcribed, and full-length RNA is electroporated into cells to produce viable viruses (Almazán et al., 2014). Importantly, fragments can be strategically divided within toxic and unstable elements, breaking up these sequences to achieve stable propagation of the sub-clones. The use of smaller plasmids for propagation and targeted mutagenesis also limits the accumulation of undesired mutations during bacterial expansion and maintains fidelity with the source CoV sequence. Together, this and other RGSs provide critical tools needed to understand CoV infection and pathogenesis.

With the development of RGSs, mutations could be easily made in the context of emergent CoVs utilizing traditional cloning methods. For instance, reporter strains for both SARS-CoV and MERS-CoV were quickly generated by replacing “accessory” ORFs with reporter genes, including GFP, RFP, and luciferase (Scobey et al., 2013; Sims et al., 2005; Yount et al., 2006). Similarly, RGSs have been key in the creation of mouse-adapted CoVs. Following *in vivo* passage, reverse genetics was used to reintroduce adaptation mutations into the SARS-CoV and MERS-CoV clones. These studies preserved a more uniform virus population and permitted the evaluation of the roles of individual mutations in mouse adaptation (Cockrell et al., 2016; Day et al., 2009; Frieman et al., 2012; Roberts et al., 2007). Reverse genetics has also been useful for the analysis of viral protein function, identifying key roles in viral antagonism of interferon (IFN) responses, inflammation, and host processes (Snijder et al., 2016). For example, ablation of nonstructural protein 16 (nsp16) function by replacing key residues at

its active sites sensitized murine hepatitis virus (MHV) and SARS-CoV to the Type I IFN response, attenuated viral replication *in vivo*, and portended nsp16 mutants as a potential live-attenuated vaccine platform (Menachery et al., 2017, 2014; Züst et al., 2011). Similarly, RGSs have been used to develop and characterize two other live-attenuated vaccine strategies via the deletion of SARS-CoV E or the inactivation of the exonuclease (ExoN) activity encoded within nsp14 (DeDiego et al., 2007; Fett et al., 2013; Graham et al., 2012; Netland et al., 2010). Together, RGSs have been key in characterizing CoV infection and defining viral protein function in the context of infection.

RGSs also have utility in analyzing the emergence and pathogenic potential of zoonotic CoVs. Because of the plasticity afforded by the sub-cloning system, sequences derived from zoonotic CoVs could be evaluated in the context of viable CoV genomes. For example, human-civet SARS-CoV chimeras were used to demonstrate that the S gene of civet strains cannot efficiently mediate viral replication in cells expressing human ACE2, even within a human strain's backbone, suggesting that S mutations were critical for human emergence of SARS-CoV (Sheahan et al., 2008). Additionally, a significant barrier to the study of zoonotic CoVs, including HKU3-CoV and HKU5-CoV, was the difficulty in finding a viable culture system either due to receptor compatibility or possible issues with the overall viral genome. Using reverse genetics, substitution of minimal S portions was used to overcome receptor-binding issues, with *de novo* synthesized HKU3 and HKU5 genomes being made viable by substituting in portions of the SARS-CoV S genes (Fig. 3A). When assembled, these chimeric viruses could infect and replicate efficiently *in vitro* and *in vivo*, demonstrating that receptor binding was a primary barrier for HKU3 and HKU5 infection of human cells (Agnihothram et al., 2014b; Becker et al., 2008). While insertion the SARS-CoV RBD was sufficient to confer replication competency to HKU3, the entire SARS-CoV ectodomain was required for HKU5, suggesting that multiple domains of the S protein may work in concert across a CoV group (Agnihothram et al., 2014b). A complementary strategy was used to test the capacity of CoV S genes to mediate infection independent of their backbones (Fig. 3B). Recently utilized with SHC014-CoV and WIV1-CoV, the S genes of zoonotic CoVs were inserted into a replication-competent backbone, the mouse adapted SARS-CoV MA15. The SHC014-MA15 and WIV1-MA15 chimeras could replicate *in vitro* and *in vivo*, suggesting that these viruses are poised for human emergence (Menachery et al., 2015, 2016). These

initial studies justified further examinations and characterizations of full-length SHC014-CoV and WIV1-CoV and indicated that mutations in the viral backbones are also required for emergence and pathogenesis. Together, these two strategies leverage reverse genetics to create chimeric coronaviruses, bypassing the limitations of species specific culture systems to analyze the emergence potential of zoonotic CoVs.

As demonstrated above, RGSs are an indispensable tool for the characterization of both human and zoonotic CoVs. Future studies will continue to exploit the utility of reverse genetics to investigate viral protein function and to identify CoV therapeutic candidates, including live-attenuated vaccine candidates based on viral protein inactivation or deletion. Additionally, the practice of creating chimeric viruses consisting of viable portions from established CoVs in conjunction with zoonotic sequences can greatly enhance the utility of metagenomic studies. Construction of these chimeras could also prove useful in vaccine and therapeutic development, as a candidate's efficacy against zoonotic strains may predict its utility against future emergent viruses. However, reverse genetic studies involving the creation of these chimeras raise biosafety concerns, particularly in light of the recent pause on gain of function studies associated with influenza and coronaviruses. While risks of research of this nature should not be taken lightly (Weiss et al., 2015), it is important to take into consideration that the experiments described above have provided invaluable information regarding zoonosis (Racaniello, 2016). Manipulation of viral pathogens using reverse genetics systems is a proven strategy for the characterization of pathogens and the development of therapeutics and the debate about its future role in biomedical research should be discussed in an evidence based fashion (Casadevall and Imperiale, 2014). Future studies need to be designed with oversight and discussion from the scientific community and should seek to strike a balance between the utility of the information gained with the potential risks involved.

4. Concluding remarks

Since the emergence of SARS-CoV, metagenomics, structural, and reverse genetics studies have been critical research approaches in the study of CoVs. Investigators have utilized viral metagenomics to define the evolutionary histories of many human CoV strains and has been instrumental in identifying numerous zoonotic CoVs circulating in animal populations. Researchers have built structural models of the S protein that have provided molecular explanations for host tropism and have identified epitope candidates for therapeutic development. Creation of reverse genetics systems by members of the field has been critical for the manipulation of viral sequences, for enhancing our understanding of CoV protein function and host adaptation, and for developing live-attenuated vaccine platforms. Together, studies utilizing these strategies have informed our current understanding of CoV emergence, pathogenesis, and treatment.

While these strategies have been used individually, future work can take advantage of their complementary nature. For instance, recent findings with MERS-CoV indicate its exploitation of α 2,6-linked sialic acids acts as a secondary receptor through the N-terminal domain (NTD) of S1, which is structurally conserved (Li et al., 2017) but divergent in sequence among CoVs (Fig. 2D) (Li et al., 2017; Walls et al., 2016a, 2016b; Yuan et al., 2017). Reverse genetics can be used to create mutants and chimeras to determine the effect sialic acid binding has on host tropism and to determine if this function of the NTD is conserved across similar zoonotic CoVs strains. Similarly, creating chimeric viruses through reverse genetics has already proven vital in the study of zoonotic viruses (Agnihothram et al., 2014b; Becker et al., 2008; Menachery et al., 2015, 2016; Sheahan et al., 2008); efforts to explore changes in the structure of proteins from zoonotic strains relative to the established strains may reveal structural requirements necessary for emergence. Reverse genetic and structural studies, by identifying conserved features associated with emergence and pathogenesis, can help identify which CoVs identified in animal populations are likely to pose a

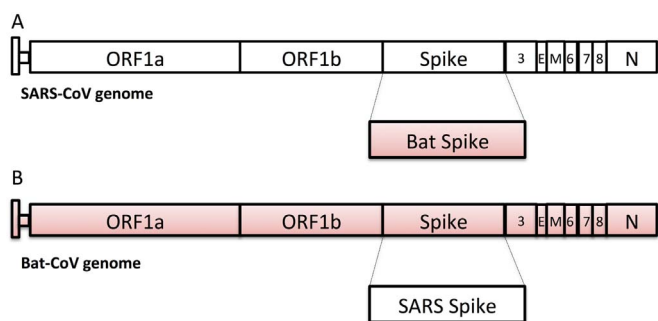

Fig. 3. Dual approaches to leverage reverse genetics. Utilizing coronavirus molecular clones, two strategies have been employed to explore the emergence and pathogenic potential of sequences derived from zoonotic populations. A) Replacing the wild-type spike proteins, this strategy explores the capacity of the spike proteins within the context of a viral backbone known to be capable of replication. These studies provide insights into the potential of spike proteins to mediate infection of human cells and cause *in vivo* disease and aid in examinations of the broad efficacy of therapeutics directed against CoV spike proteins. B) Utilizing portions or whole spike proteins of replication-competent CoVs, this approach examines the capacity of the viral backbone in mediating infection and pathogenesis. These studies provide insights into whether the backbone has the capacity to infect and cause disease if paired with receptor binding/entry. This approach can also evaluate the efficacy of therapeutics targeting portions of the CoV genome other than spike. Both approaches have been used to examine bat viruses currently circulating in animal populations around the world.

public health risk and merit further study. Additionally, insights from these strategies can be applied to existing experimental systems. For example, variation in host response to infection is currently a major area of research (Aylor et al., 2011; Menachery and Baric, 2013) and models of host genetic diversity, such as collaborative cross (CC) mouse panel, have identified genetic loci that modulate SARS-CoV disease outcome (Gralinski et al., 2015, 2017; Xiong et al., 2014). Applying insights from viral metagenomics, structure, and reverse genetics, offer the opportunity to utilize the CC to identify host genes that contribute to emergence of zoonotic CoVs. Similarly, host-pathogen interactions may influence and modulate both viral sequence and structure; reverse genetic systems can be utilized to confirm these hypotheses. Together, the synergistic use of metagenomics, structural biology, and reverse genetic systems has significant potential to identify the molecular determinates of CoV infection and pathogenesis. Integration of these three strategies can help characterize pre-emergent CoV populations, allowing to the field to make predictions about which zoonotic CoVs are likely to emerge, prepare for future outbreaks, and will facilitate the development of therapeutic strategies against CoV infection.

Acknowledgements

Research in this manuscript was supported by grants from the National Institute of Allergy & Infectious Disease and the National Institute of Aging of the NIH under awards U19 AI109761 (RLG), U19AI100625 (VDM), and R00AG049092 (VDM). The content is solely the responsibility of the authors and does not necessarily represent the official views of the NIH.

References

Agnihotram, S., Gopal, R., Yount, B.L., Donaldson, E.F., Menachery, V.D., Graham, R.L., Scobey, T.D., Gralinski, L.E., Denison, M.R., Zambon, M., Baric, R.S., 2014a. Evaluation of serologic and antigenic relationships between middle eastern respiratory syndrome coronavirus and other coronaviruses to develop vaccine platforms for the rapid response to emerging coronaviruses. *J. Infect. Dis.* 209, 995–1006.

Agnihotram, S., Yount, B.L., Donaldson, E.F., Huynh, J., Menachery, V.D., Gralinski, L.E., Graham, R.L., Becker, M.M., Tomar, S., Scobey, T.D., Osswald, H.L., Whitmore, A., Gopal, R., Ghosh, A.K., Mesecar, A., Zambon, M., Heise, M., Denison, M.R., Baric, R.S., 2014b. A mouse model for Betacoronavirus subgroup 2c using a bat coronavirus strain HKU5 variant. *MBio* 5, e00047–00014.

Alagaili, A.N., Briese, T., Mishra, N., Kapoor, V., Sameroff, S.C., Burbelo, P.D., de Wit, E., Munster, V.J., Hensley, L.E., Zalmout, I.S., Kapoor, A., Epstein, J.H., Karesh, W.B., Daszak, P., Mohammed, O.B., Lipkin, W.I., 2014. Middle East respiratory syndrome coronavirus infection in dromedary camels in Saudi Arabia. *MBio* 5, e00884–00814.

Almazán, F., Sola, I., Zuñiga, S., Marquez-Jurado, S., Morales, L., Becares, M., Enjuanes, L., 2014. Reprint of: coronavirus reverse genetic systems: infectious clones and replicons. *Virus Res.* 194, 67–75.

Annan, A., Baldwin, H.J., Corman, V.M., Klose, S.M., Owusu, M., Nkrumah, E.E., Badu, E.K., Antti, P., Agbenyega, O., Meyer, B., Oppong, S., Sarkodie, Y.A., Kalko, E.K., Lina, P.H., Godlevska, E.V., Reusken, C., Seebens, A., Gloza-Rausch, F., Vallo, P., Tschapka, M., Drosten, C., Drexler, J.F., 2013. Human betacoronavirus 2c EMC/2012-related viruses in bats, Ghana and Europe. *Emerg. Infect. Dis.* 19, 456–459.

Anthony, S.J., Gilardi, K., Menachery, V.D., Goldstein, T., Ssebide, B., Mbabazi, R., Navarrete-Macias, I., Liang, E., Wells, H., Hicks, A., Petrosov, A., Byarugaba, D.K., Debbink, K., Dinno, K.H., Scobey, T., Randell, S.H., Yount, B.L., Cranfield, M., Johnson, C.K., Baric, R.S., Lipkin, W.I., Mazet, J.A., 2017. Further evidence for bats as the evolutionary source of middle east respiratory syndrome coronavirus. *MBio* 8.

Anthony, S.J., Ojeda-Flores, R., Rico-Chávez, O., Navarrete-Macias, I., Zambrana-Torrel, C.M., Rostal, M.K., Epstein, J.H., Tipps, T., Liang, E., Sanchez-Leon, M., Sotomayor-Bonilla, J., Aguirre, A.A., Ávila-Flores, R., Medellín, R.A., Goldstein, T., Suzán, G., Daszak, P., Lipkin, W.I., 2013. Coronaviruses in bats from Mexico. *J. Gen. Virol.* 94, 1028–1038.

Aylor, D.L., Valdar, W., Foulds-Mathes, W., Buus, R.J., Verdugo, R.A., Baric, R.S., Ferris, M.T., Frelinger, J.A., Heise, M., Frieman, M.B., Gralinski, L.E., Bell, T.A., Didion, J.D., Hua, K., Nehrenberg, D.L., Powell, C.L., Steigerwalt, J., Xie, Y., Kelada, S.N., Collins, F.S., Yang, I.V., Schwartz, D.A., Branstetter, L.A., Chesler, E.J., Miller, D.R., Spence, J., Liu, E.Y., McMillan, L., Sarkar, A., Wang, J., Wang, W., Zhang, Q., Broman, K.W., Korstanje, R., Durrant, C., Mott, R., Iraqi, F.A., Pomp, D., Threadgill, D., de Villena, F.P., Churchill, G.A., 2011. Genetic analysis of complex traits in the emerging Collaborative Cross. *Genome Res.* 21, 1213–1222.

Azhar, E.I., El-Kafrawy, S.A., Farraj, S.A., Hassan, A.M., Al-Saeed, M.S., Hashem, A.M., Madani, T.A., 2014. Evidence for camel-to-human transmission of MERS coronavirus. *N. Engl. J. Med.* 370, 2499–2505.

Barlan, A., Zhao, J., Sarkar, M.K., Li, K., McCray, P.B., Perlman, S., Gallagher, T., 2014. Receptor variation and susceptibility to Middle East respiratory syndrome

coronavirus infection. *J. Virol.* 88, 4953–4961.

Beall, A., Yount, B., Lin, C.M., Hou, Y., Wang, Q., Saif, L., Baric, R., 2016. Characterization of a pathogenic Full-Length cDNA clone and transmission model for porcine epidemic diarrhea virus strain PC22A. *MBio* 7, e01451–01415.

Becker, M.M., Graham, R.L., Donaldson, E.F., Rockx, B., Sims, A.C., Sheahan, T., Pickles, R.J., Corti, D., Johnston, R.E., Baric, R.S., Denison, M.R., 2008. Synthetic recombinant bat SARS-like coronavirus is infectious in cultured cells and in mice. *Proc. Natl. Acad. Sci. USA* 105, 19944–19949.

Beniac, D.R., deVarenes, S.L., Andonov, A., He, R., Booth, T.F., 2007. Conformational reorganization of the SARS coronavirus spike following receptor binding: implications for membrane fusion. *PLoS One* 2, e1082.

Briese, T., Mishra, N., Jain, K., Zalmout, I.S., Jabado, O.J., Karesh, W.B., Daszak, P., Mohammed, O.B., Alagaili, A.N., Lipkin, W.I., 2014. Middle East respiratory syndrome coronavirus quasispecies that include homologues of human isolates revealed through whole-genome analysis and virus cultured from dromedary camels in Saudi Arabia. *MBio* 5, e01146–01114.

Cao, Z., Liu, L., Du, L., Zhang, C., Jiang, S., Li, T., He, Y., 2010. Potent and persistent antibody responses against the receptor-binding domain of SARS-CoV spike protein in recovered patients. *Virol. J.* 7, 299.

Casadevall, A., Imperiale, M.J., 2014. Risks and benefits of gain-of-function experiments with pathogens of pandemic potential, such as influenza virus: a call for a science-based discussion. *MBio* 5, e01730–01714.

Chen, Y., Rajashankar, K.R., Yang, Y., Agnihotram, S.S., Liu, C., Lin, Y.L., Baric, R.S., Li, F., 2013. Crystal structure of the receptor-binding domain from newly emerged Middle East respiratory syndrome coronavirus. *J. Virol.* 87, 10777–10783.

Cockrell, A.S., Yount, B.L., Scobey, T., Jensen, K., Douglas, M., Beall, A., Tang, X.C., Marasco, W.A., Heise, M.T., Baric, R.S., 2016. A mouse model for MERS coronavirus-induced acute respiratory distress syndrome. *Nat. Microbiol.* 2, 16226.

Coleman, C.M., Matthews, K.L., Goicochea, L., Frieman, M.B., 2014. Wild-type and innate immune-deficient mice are not susceptible to the Middle East respiratory syndrome coronavirus. *J. Gen. Virol.* 95, 408–412.

Corman, V.M., Ithete, N.L., Richards, L.R., Schoeman, M.C., Preiser, W., Drosten, C., Drexler, J.F., 2014. Rooting the phylogenetic tree of middle East respiratory syndrome coronavirus by characterization of a conspecific virus from an African bat. *J. Virol.* 88, 11297–11303.

Cotten, M., Lam, T.T., Watson, S.J., Palser, A.L., Petrova, V., Grant, P., Pybus, O.G., Rambaut, A., Guan, Y., Pillay, D., Kellam, P., Nastouli, E., 2013a. Full-genome deep sequencing and phylogenetic analysis of novel human betacoronavirus. *Emerg. Infect. Dis.* 19, 736–742B.

Cotten, M., Watson, S.J., Kellam, P., Al-Rabeeah, A.A., Makhdoom, H.Q., Assiri, A., Al-Tawfiq, J.A., Alhakeem, R.F., Madani, H., AlRabiah, F.A., Al Hajjar, S., Al-nassir, W.N., Albarrak, A., Flemban, H., Balkhy, H.H., Alsubaie, S., Palser, A.L., Gall, A., Bashford-Rogers, R., Rambaut, A., Zumla, A.I., Memish, Z.A., 2013b. Transmission and evolution of the Middle East respiratory syndrome coronavirus in Saudi Arabia: a descriptive genomic study. *Lancet* 382, 1993–2002.

Cotten, M., Watson, S.J., Zumla, A.I., Makhdoom, H.Q., Palser, A.L., Ong, S.H., Al-Rabeeah, A.A., Alhakeem, R.F., Assiri, A., Al-Tawfiq, J.A., Albarrak, A., Barry, M., Shibl, A., Alrabiah, F.A., Hajjar, S., Balkhy, H.H., Flemban, H., Rambaut, A., Kellam, P., Memish, Z.A., 2014. Spread, circulation, and evolution of the Middle East respiratory syndrome coronavirus. *MBio* 5.

Day, C.W., Baric, R., Cai, S.X., Frieman, M., Kumaki, Y., Morrey, J.D., Smee, D.F., Barnard, D.L., 2009. A new mouse-adapted strain of SARS-CoV as a lethal model for evaluating antiviral agents in vitro and in vivo. *Virology* 395, 210–222.

de Wit, E., Prescott, J., Baseler, L., Bushmaker, T., Thomas, T., Lackemeyer, M.G., Martellaro, C., Milne-Price, S., Haddock, E., Haagmans, B.L., Feldmann, H., Munster, V.J., 2013. The middle East respiratory syndrome coronavirus (MERS-CoV) does not replicate in Syrian hamsters. *PLoS One* 8, e69127.

DeDiego, M.L., Alvarez, E., Almazán, F., Rejas, M.T., Lamirande, E., Roberts, A., Shieh, W.-J., Zaki, S.R., Subbarao, K., Enjuanes, L., 2007. A severe acute respiratory syndrome coronavirus that lacks the E gene is attenuated in vitro and in vivo. *J. Virol.* 81, 1701–1713.

Donaldson, E.F., Haskew, A.N., Gates, J.E., Huynh, J., Moore, C.J., Frieman, M.B., 2010. Metagenomic analysis of the viromes of three North American bat species: viral diversity among different bat species that share a common habitat. *J. Virol.* 84, 13004–13018.

Drexler, J.F., Corman, V.M., Drosten, C., 2014. Ecology, evolution and classification of bat coronaviruses in the aftermath of SARS. *Antivir. Res.* 101, 45–56.

Drosten, C., Gunther, S., Preiser, W., van der Werf, S., Brodt, H.R., Becker, S., Rabenau, H., Panning, M., Kolesnikova, L., Fouchier, R.A., Berger, A., Burguiera, A.M., Cinatl, J., Eickmann, M., Escriou, N., Grynwa, K., Kramme, S., Manuguerra, J.C., Müller, S., Rickerts, V., Stürmer, M., Vieth, S., Klenk, H.D., Osterhaus, A.D., Schmitz, H., Doerr, H.W., 2003. Identification of a novel coronavirus in patients with severe acute respiratory syndrome. *N. Engl. J. Med.* 348, 1967–1976.

Du, L., Kou, Z., Ma, C., Tao, X., Wang, L., Zhao, G., Chen, Y., Yu, F., Tseng, C.T., Zhou, Y., Jiang, S., 2013a. A truncated receptor-binding domain of MERS-CoV spike protein potentially inhibits MERS-CoV infection and induces strong neutralizing antibody responses: implication for developing therapeutics and vaccines. *PLoS One* 8, e81587.

Du, L., Zhao, G., He, Y., Guo, Y., Zheng, B.J., Jiang, S., Zhou, Y., 2007. Receptor-binding domain of SARS-CoV spike protein induces long-term protective immunity in an animal model. *Vaccine* 25, 2832–2838.

Du, L., Zhao, G., Kou, Z., Ma, C., Sun, S., Poon, V.K., Lu, L., Wang, L., Debnath, A.K., Zheng, B.J., Zhou, Y., Jiang, S., 2013b. Identification of a receptor-binding domain in the S protein of the novel human coronavirus Middle East respiratory syndrome coronavirus as an essential target for vaccine development. *J. Virol.* 87, 9939–9942.

Edwards, R.A., Rohwer, F., 2005. Viral metagenomics. *Nat. Rev. Microbiol.* 3, 504–510.

Falzarano, D., de Wit, E., Feldmann, F., Rasmussen, A.L., Okumura, A., Peng, X., Thomas,

- McLellan, J.S., Scott, D.P., Katze, M.G., Feldmann, H., Munster, V.J., 2014. Infection with MERS-CoV causes lethal pneumonia in the common marmoset. *PLoS Pathog.* 10, e1004250.
- Fett, C., DeDiego, M.L., Regla-Nava, J.A., Enjuanes, L., Perlman, S., 2013. Complete protection against severe acute respiratory syndrome coronavirus-mediated lethal respiratory disease in aged mice by immunization with a mouse-adapted virus lacking E protein. *J. Virol.* 87, 6551–6559.
- Frieman, M., Yount, B., Agnihothram, S., Page, C., Donaldson, E., Roberts, A., Vogel, L., Woodruff, B., Scorpio, D., Subbarao, K., Baric, R.S., 2012. Molecular determinants of severe acute respiratory syndrome coronavirus pathogenesis and virulence in young and aged mouse models of human disease. *J. Virol.* 86, 884–897.
- Ge, X.Y., Li, J.L., Yang, X.L., Chmura, A.A., Zhu, G., Epstein, J.H., Mazet, J.K., Hu, B., Zhang, W., Peng, C., Zhang, Y.J., Luo, C.M., Tan, B., Wang, N., Zhu, Y., Cramer, G., Zhang, S.Y., Wang, L.F., Daszak, P., Shi, Z.L., 2013. Isolation and characterization of a bat SARS-like coronavirus that uses the ACE2 receptor. *Nature* 503, 535–538.
- Graham, R.L., Becker, M.M., Eckerle, L.D., Bolles, M., Denison, M.R., Baric, R.S., 2012. A live, impaired-fidelity coronavirus vaccine protects in an aged, immunocompromised mouse model of lethal disease. *Nat. Med.* 18, 1820–1826.
- Gralinski, L.E., Ferris, M.T., Aylor, D.L., Whitmore, A.C., Green, R., Frieman, M.B., Deming, D., Menachery, V.D., Miller, D.R., Buus, R.J., Bell, T.A., Churchill, G.A., Threadgill, D.W., Katze, M.G., McMillan, L., Valdar, W., Heise, M.T., Pardo-Manuel de Villena, F., Baric, R.S., 2015. Genome Wide Identification of SARS-CoV Susceptibility Loci Using the Collaborative Cross. *PLoS Genet.* 11, e1005504.
- Gralinski, L.E., Menachery, V.D., Morgan, A.P., Totura, A.L., Beall, A., Kocher, J., Plante, J., Harrison-Shostak, D.C., Schäfer, A., Pardo-Manuel de Villena, F., Ferris, M.T., Baric, R.S., 2017. Allelic variation in the toll-like receptor adaptor protein Ticam2 contributes to SARS-coronavirus pathogenesis in mice. *G3* 7, 1653–1663.
- Guan, Y., Zheng, B.J., He, Y.Q., Liu, X.L., Zhuang, Z.X., Cheung, C.L., Luo, S.W., Li, P.H., Zhang, L.J., Guan, Y.J., Butt, K.M., Wong, K.L., Chan, K.W., Lim, W., Shortridge, K.F., Yuen, K.Y., Peiris, J.S., Poon, L.L., 2003. Isolation and characterization of viruses related to the SARS coronavirus from animals in southern China. *Science* 302, 276–278.
- Haagmans, B.L., Al Dhahiry, S.H., Reusken, C.B., Raj, V.S., Galiano, M., Myers, R., Godeke, G.J., Jonges, M., Farag, E., Diab, A., Ghobashy, H., Alhajri, F., Al-Thani, M., Al-Marri, S.A., Al Romaihi, H.E., Al Khal, A., Bermingham, A., Osterhaus, A.D., Alhajri, M.M., Koopmans, M.P., 2014. Middle East respiratory syndrome coronavirus in dromedary camels: an outbreak investigation. *Lancet Infect. Dis.* 14, 140–145.
- He, B., Zhang, Y., Xu, L., Yang, W., Yang, F., Feng, Y., Xia, L., Zhou, J., Zhen, W., Feng, Y., Guo, H., Zhang, H., Tu, C., 2014. Identification of diverse alphacoronaviruses and genomic characterization of a novel severe acute respiratory syndrome-like coronavirus from bats in China. *J. Virol.* 88, 7070–7082.
- He, Y., Li, J., Heck, S., Lustigman, S., Jiang, S., 2006. Antigenic and immunogenic characterization of recombinant baculovirus-expressed severe acute respiratory syndrome coronavirus spike protein: implication for vaccine design. *J. Virol.* 80, 5757–5767.
- He, Y., Lu, H., Siddiqui, P., Zhou, Y., Jiang, S., 2005a. Receptor-binding domain of severe acute respiratory syndrome coronavirus spike protein contains multiple conformation-dependent epitopes that induce highly potent neutralizing antibodies. *J. Immunol.* 174, 4908–4915.
- He, Y., Zhou, Y., Liu, S., Kou, Z., Li, W., Farzan, M., Jiang, S., 2004. Receptor-binding domain of SARS-CoV spike protein induces highly potent neutralizing antibodies: implication for developing subunit vaccine. *Biochem. Biophys. Res. Commun.* 324, 773–781.
- He, Y., Zhu, Q., Liu, S., Zhou, Y., Yang, B., Li, J., Jiang, S., 2005b. Identification of a critical neutralization determinant of severe acute respiratory syndrome (SARS)-associated coronavirus: importance for designing SARS vaccines. *Virology* 334, 74–82.
- Hemida, M.G., Chu, D.K., Poon, L.L., Perera, R.A., Alhammadi, M.A., Ng, H.Y., Siu, L.Y., Guan, Y., Alnaeem, A., Peiris, M., 2014. MERS coronavirus in dromedary camel herd, Saudi Arabia. *Emerg. Infect. Dis.* 20, 1231–1234.
- Hou, Y., Peng, C., Yu, M., Li, Y., Han, Z., Li, F., Wang, L.F., Shi, Z., 2010. Angiotensin-converting enzyme 2 (ACE2) proteins of different bat species confer variable susceptibility to SARS-CoV entry. *Arch. Virol.* 155, 1563–1569.
- Ithete, N.L., Stoffberg, S., Corman, V.M., Cottontail, V.M., Richards, L.R., Schoeman, M.C., Drosten, C., Drexler, J.F., Preiser, W., 2013. Close relative of human Middle East respiratory syndrome coronavirus in bat, South Africa. *Emerg. Infect. Dis.* 19, 1697–1699.
- Kang, C., Keller, T.H., Luo, D., 2017. Zika virus protease: an antiviral drug target. *Trends Microbiol.*
- Kirchdoerfer, R.N., Cottrell, C.A., Wang, N., Pallesen, J., Yassine, H.M., Turner, H.L., Corbett, K.S., Graham, B.S., McLellan, J.S., Ward, A.B., 2016. Pre-fusion structure of a human coronavirus spike protein. *Nature* 531, 118–121.
- Ksiazek, T.G., Erdman, D., Goldsmith, C.S., Zaki, S.R., Peret, T., Emery, S., Tong, S., Urbani, C., Comer, J.A., Lim, W., Rollin, P.E., Dowell, S.F., Ling, A.E., Humphrey, C.D., Shieh, W.J., Guarner, J., Paddock, C.D., Rota, P., Fields, B., DeRisi, J., Yang, J.Y., Cox, N., Hughes, J.M., LeDuc, J.W., Bellini, W.J., Anderson, L.J., Group, S.W., 2003. A novel coronavirus associated with severe acute respiratory syndrome. *N. Engl. J. Med.* 348, 1953–1966.
- Lau, S.K., Woo, P.C., Li, K.S., Huang, Y., Tsoi, H.W., Wong, B.H., Wong, S.S., Leung, S.Y., Chan, K.H., Yuen, K.Y., 2005. Severe acute respiratory syndrome coronavirus-like virus in Chinese horseshoe bats. *Proc. Natl. Acad. Sci. USA* 102, 14040–14045.
- Li, F., 2008. Structural analysis of major species barriers between humans and palm civets for severe acute respiratory syndrome coronavirus infections. *J. Virol.* 82, 6984–6991.
- Li, F., 2013. Receptor recognition and cross-species infections of SARS coronavirus. *Antivir. Res.* 100, 246–254.
- Li, F., Li, W., Farzan, M., Harrison, S.C., 2005a. Structure of SARS coronavirus spike receptor-binding domain complexed with receptor. *Science* 309, 1864–1868.
- Li, W., Hulsit, R.J.G., Widjaja, I., Raj, V.S., McBride, R., Peng, W., Widagdo, W., Torrici, M.A., van Dieren, B., Lang, Y., van Lent, J.W.M., Paulson, J.C., de Haan, C.A.M., de Groot, R.J., van Kuppeveld, F.J.M., Haagmans, B.L., Bosch, B.J., 2017. Identification of sialic acid-binding function for the Middle East respiratory syndrome coronavirus spike glycoprotein. *Proc. Natl. Acad. Sci. USA*.
- Li, W., Shi, Z., Yu, M., Ren, W., Smith, C., Epstein, J.H., Wang, H., Cramer, G., Hu, Z., Zhang, H., Zhang, J., McEachern, J., Field, H., Daszak, P., Eaton, B.T., Zhang, S., Wang, L.F., 2005a. Bats are natural reservoirs of SARS-like coronaviruses. *Science* 310, 676–679.
- Li, W., Zhang, C., Sui, J., Kuhn, J.H., Moore, M.J., Luo, S., Wong, S.K., Huang, I.C., Xu, K., Vasilieva, N., Murakami, A., He, Y., Marasco, W.A., Guan, Y., Choe, H., Farzan, M., 2005b. Receptor and viral determinants of SARS-coronavirus adaptation to human ACE2. *EMBO J.* 24, 1634–1643.
- Lu, G., Hu, Y., Wang, Q., Qi, J., Gao, F., Li, Y., Zhang, Y., Zhang, W., Yuan, Y., Bao, J., Zhang, B., Shi, Y., Yan, J., Gao, G.F., 2013. Molecular basis of binding between novel human coronavirus MERS-CoV and its receptor CD26. *Nature* 500, 227–231.
- Lu, G., Wang, Q., Gao, G.F., 2015. Bat-to-human: spike features determining 'host jump' of coronaviruses SARS-CoV, MERS-CoV, and beyond. *Trends Microbiol.* 23, 468–478.
- Lu, L., Manopo, I., Leung, B.P., Chng, H.H., Ling, A.E., Chee, L.L., Ooi, E.E., Chan, S.W., Kwang, J., 2004. Immunological characterization of the spike protein of the severe acute respiratory syndrome coronavirus. *J. Clin. Microbiol.* 42, 1570–1576.
- Menachery, V.D., Baric, R.S., 2013. Bugs in the system. *Immunol. Rev.* 255, 256–274.
- Menachery, V.D., Gralinski, L.E., Mitchell, H.D., Dinnon, K.H., Leist, S.R., Yount, B.L., Graham, R.L., McAnarney, E.T., Stratton, K.G., Cockrell, A.S., Debbink, K., Sims, A.C., Waters, K.M., Baric, R.S., 2017. Middle east respiratory syndrome coronavirus non-structural protein 16 is necessary for interferon resistance and viral pathogenesis. *mSphere* 2.
- Menachery, V.D., Yount, B.L., Josset, L., Gralinski, L.E., Scobey, T., Agnihothram, S., Katze, M.G., Baric, R.S., 2014. Attenuation and restoration of severe acute respiratory syndrome coronavirus mutant lacking 2'-O-methyltransferase activity. *J. Virol.* 88, 4251–4264.
- Menachery, V.D., Yount Jr., B.L., Debbink, K., Agnihothram, S., Gralinski, L.E., Plante, J.A., Graham, R.L., Scobey, T., Ge, X.Y., Donaldson, E.F., Randell, S.H., Lanzavecchia, A., Marasco, W.A., Shi, Z.L., Baric, R.S., 2015. A SARS-like cluster of circulating bat coronaviruses shows potential for human emergence. *Nat. Med.* 21, 1508–1513.
- Menachery, V.D., Yount Jr., B.L., Sims, A.C., Debbink, K., Agnihothram, S.S., Gralinski, L.E., Graham, R.L., Scobey, T., Plante, J.A., Royal, S.R., Swanstrom, J., Sheahan, T.P., Pickles, R.J., Corti, D., Randell, S.H., Lanzavecchia, A., Marasco, W.A., Baric, R.S., 2016. SARS-like WIV1-CoV poised for human emergence. *Proc. Natl. Acad. Sci. USA* 113, 3048–3053.
- Mou, H., Raj, V.S., van Kuppeveld, F.J., Rottier, P.J., Haagmans, B.L., Bosch, B.J., 2013. The receptor binding domain of the new middle East respiratory syndrome coronavirus maps to a 231-residue region in the spike protein that efficiently elicits neutralizing antibodies. *J. Virol.* 87, 9379–9383.
- Muller, M.A., Corman, V.M., Jores, J., Meyer, B., Younan, M., Liljander, A., Bosch, B.J., Lattwein, E., Hilali, M., Musa, B.E., Bornstein, S., Drosten, C., 2014. MERS coronavirus neutralizing antibodies in camels, Eastern Africa, 1983–1997. *Emerg. Infect. Dis.* 20, 2093–2095.
- Müller, M.A., Raj, V.S., Muth, D., Meyer, B., Kallies, S., Smits, S.L., Wollny, R., Bestebroer, T.M., Specht, S., Suliman, T., Zimmermann, K., Binger, T., Eckerle, I., Tschapka, M., Zaki, A.M., Osterhaus, A.D., Fouchier, R.A., Haagmans, B.L., Drosten, C., 2012. Human coronavirus EMC does not require the SARS-coronavirus receptor and maintains broad replicative capability in mammalian cell lines. *MBio* 3.
- Netland, J., DeDiego, M.L., Zhao, J., Fett, C., Alvarez, E., Nieto-Torres, J.L., Enjuanes, L., Perlman, S., 2010. Immunization with an attenuated severe acute respiratory syndrome coronavirus deleted in E protein protects against lethal respiratory disease. *Virology* 399, 120–128.
- Neuman, B.W., Adair, B.D., Yoshioka, C., Quispe, J.D., Orca, G., Kuhn, P., Milligan, R.A., Yeager, M., Buchmeier, M.J., 2006. Supramolecular architecture of severe acute respiratory syndrome coronavirus revealed by electron cryomicroscopy. *J. Virol.* 80, 7918–7928.
- Pallesen, J., Wang, N., Corbett, K.S., Wrapp, D., Kirchdoerfer, R.N., Turner, H.L., Cottrell, C.A., Becker, M.M., Wang, L., Shi, W., Kong, W.P., Andres, E.L., Kettenbach, A.N., Denison, M.R., Chappell, J.D., Graham, B.S., Ward, A.B., McLellan, J.S., 2017. Immunogenicity and structures of a rationally designed prefusion MERS-CoV spike antigen. *Proc. Natl. Acad. Sci. USA* 114, E7348–E7357.
- Peiris, J.S., Lai, S.T., Poon, L.L., Guan, Y., Yam, L.Y., Lim, W., Nicholls, J., Yee, W.K., Yan, W.W., Cheung, M.T., Cheng, V.C., Chan, K.H., Tsang, D.N., Yung, R.W., Ng, T.K., Yuen, K.Y., group, Ss, 2003a. Coronavirus as a possible cause of severe acute respiratory syndrome. *Lancet* 361, 1319–1325.
- Peiris, J.S., Yuen, K.Y., Osterhaus, A.D., Stöhr, K., 2003b. The severe acute respiratory syndrome. *N. Engl. J. Med.* 349, 2431–2441.
- Perez, D., 2017. Reverse Genetics of RNA Viruses. Springer Science + Business Media, New York, NY.
- Poon, L.L., Chu, D.K., Chan, K.H., Wong, O.K., Ellis, T.M., Leung, Y.H., Lau, S.K., Woo, P.C., Suen, K.Y., Yuen, K.Y., Guan, Y., Peiris, J.S., 2005. Identification of a novel coronavirus in bats. *J. Virol.* 79, 2001–2009.
- Qu, X.X., Hao, P., Song, X.J., Jiang, S.M., Liu, Y.X., Wang, P.G., Rao, X., Song, H.D., Wang, S.Y., Zuo, Y., Zheng, A.H., Luo, M., Wang, H.L., Deng, F., Wang, H.Z., Hu, Z.H., Ding, M.X., Zhao, G.P., Deng, H.K., 2005. Identification of two critical amino acid residues of the severe acute respiratory syndrome coronavirus spike protein for its variation in zoonotic tropism transition via a double substitution strategy. *J. Biol. Chem.* 280, 29588–29595.
- Racaniello, V., 2016. Moving beyond metagenomics to find the next pandemic virus.

- Proc. Natl. Acad. Sci. USA 113, 2812–2814.
- Raj, V.S., Smits, S.L., Provacia, L.B., van den Brand, J.M., Wiersma, L., Ouwendijk, W.J., Bestebroer, T.M., Spronken, M.I., van Amerongen, G., Rottier, P.J., Fouchier, R.A., Bosch, B.J., Osterhaus, A.D., Haagmans, B.L., 2014. Adenosine deaminase acts as a natural antagonist for dipeptidyl peptidase 4-mediated entry of the Middle East respiratory syndrome coronavirus. *J. Virol.* 88, 1834–1838.
- Ren, W., Li, W., Yu, M., Hao, P., Zhang, Y., Zhou, P., Zhang, S., Zhao, G., Zhong, Y., Wang, S., Wang, L.F., Shi, Z., 2006. Full-length genome sequences of two SARS-like coronaviruses in horseshoe bats and genetic variation analysis. *J. Gen. Virol.* 87, 3355–3359.
- Ren, W., Qu, X., Li, W., Han, Z., Yu, M., Zhou, P., Zhang, S.Y., Wang, L.F., Deng, H., Shi, Z., 2008. Difference in receptor usage between severe acute respiratory syndrome (SARS) coronavirus and SARS-like coronavirus of bat origin. *J. Virol.* 82, 1899–1907.
- Reusken, C.B., Haagmans, B.L., Muller, M.A., Gutierrez, C., Godeke, G.J., Meyer, B., Muth, D., Raj, V.S., Smits-De Vries, L., Corman, V.M., Drexler, J.F., Smits, S.L., El Tahir, Y.E., De Sousa, R., van Beek, J., Nowotny, N., van Maanen, K., Hidalgo-Hermoso, E., Bosch, B.J., Rottier, P., Osterhaus, A., Gortazar-Schmidt, C., Drosten, C., Koopmans, M.P., 2013. Middle East respiratory syndrome coronavirus neutralising serum antibodies in dromedary camels: a comparative serological study. *Lancet Infect. Dis.* 13, 859–866.
- Roberts, A., Deming, D., Paddock, C.D., Cheng, A., Yount, B., Vogel, L., Herman, B.D., Sheahan, T., Heise, M., Genrich, G.L., Zaki, S.R., Baric, R., Subbarao, K., 2007. A mouse-adapted SARS-coronavirus causes disease and mortality in BALB/c mice. *PLoS Pathog.* 3, e5.
- Rockx, B., Corti, D., Donaldson, E., Sheahan, T., Stadler, K., Lanzavecchia, A., Baric, R., 2008. Structural basis for potent cross-neutralizing human monoclonal antibody protection against lethal human and zoonotic severe acute respiratory syndrome coronavirus challenge. *J. Virol.* 82, 3220–3235.
- Rockx, B., Donaldson, E., Frieman, M., Sheahan, T., Corti, D., Lanzavecchia, A., Baric, R.S., 2010. Escape from human monoclonal antibody neutralization affects in vitro and in vivo fitness of severe acute respiratory syndrome coronavirus. *J. Infect. Dis.* 201, 946–955.
- Rota, P.A., Oberste, M.S., Monroe, S.S., Nix, W.A., Campagnoli, R., Icenogle, J.P., Peñaranda, S., Bankamp, B., Maher, K., Chen, M.H., Tong, S., Tamin, A., Lowe, L., France, M., DeRisi, J.L., Chen, Q., Wang, D., Erdman, D.D., Peret, T.C., Burns, C., Ksiazek, T.G., Rollin, P.E., Sanchez, A., Liffick, S., Holloway, B., Limor, J., McCaustland, K., Olsen-Rasmussen, M., Fouchier, R., Günther, S., Osterhaus, A.D., Drosten, C., Pallansch, M.A., Anderson, L.J., Bellini, W.J., 2003. Characterization of a novel coronavirus associated with severe acute respiratory syndrome. *Science* 300, 1394–1399.
- Saphire, E.O., 2013. An update on the use of antibodies against the filoviruses. *Immunotherapy* 5, 1221–1233.
- Scobey, T., Yount, B.L., Sims, A.C., Donaldson, E.F., Agnihothram, S.S., Menachery, V.D., Graham, R.L., Swanson, J., Bove, P.F., Kim, J.D., Grego, S., Randell, S.H., Baric, R.S., 2013. Reverse genetics with a full-length infectious cDNA of the Middle East respiratory syndrome coronavirus. *Proc. Natl. Acad. Sci. USA* 110, 16157–16162.
- Sheahan, T., Rockx, B., Donaldson, E., Corti, D., Baric, R., 2008. Pathways of cross-species transmission of synthetically reconstructed zoonotic severe acute respiratory syndrome coronavirus. *J. Virol.* 82, 8721–8732.
- Simmonds, P., Adams, M.J., Benkő, M., Breitbart, M., Brister, J.R., Carstens, E.B., Davison, A.J., Delwart, E., Gorbalenya, A.E., Harrach, B., Hull, R., King, A.M., Koonin, E.V., Krupovic, M., Kuhn, J.H., Lefkowitz, E.J., Nibert, M.L., Orton, R., Roossinck, M.J., Sabanadzovic, S., Sullivan, M.B., Suttle, C.A., Tesh, R.B., van der Vlugt, R.A., Varsani, A., Zerbini, F.M., 2017. Consensus statement: virus taxonomy in the age of metagenomics. *Nat. Rev. Microbiol.* 15, 161–168.
- Sims, A.C., Baric, R.S., Yount, B., Burkett, S.E., Collins, P.L., Pickles, R.J., 2005. Severe acute respiratory syndrome coronavirus infection of human ciliated airway epithelia: role of ciliated cells in viral spread in the conducting airways of the lungs. *J. Virol.* 79, 15511–15524.
- Snijder, E.J., Decroly, E., Ziebuhr, J., 2016. The Nonstructural proteins Directing Coronavirus RNA Synthesis and processing. *Adv. Virus Res.* 96, 59–126.
- Sui, J., Deming, M., Rockx, B., Liddington, R.C., Zhu, Q.K., Baric, R.S., Marasco, W.A., 2014. Effects of human anti-spike protein receptor binding domain antibodies on severe acute respiratory syndrome coronavirus neutralization escape and fitness. *J. Virol.* 88, 13769–13780.
- Tang, X.C., Zhang, J.X., Zhang, S.Y., Wang, P., Fan, X.H., Li, L.F., Li, G., Dong, B.Q., Liu, W., Cheung, C.L., Xu, K.M., Song, W.J., Vijaykrishna, D., Poon, L.L., Peiris, J.S., Smith, G.J., Chen, H., Guan, Y., 2006. Prevalence and genetic diversity of coronaviruses in bats from China. *J. Virol.* 80, 7481–7490.
- Tao, Y., Shi, M., Chommanard, C., Queen, K., Zhang, J., Markotter, W., Kuzmin, I.V., Holmes, E.C., Tong, S., 2017. Surveillance of Bat Coronaviruses in Kenya Identifies Relatives of Human Coronaviruses NL63 and 229E and Their Recombination History. *J. Virol.* 91.
- Tu, C., Cramer, G., Kong, X., Chen, J., Sun, Y., Yu, M., Xiang, H., Xia, X., Liu, S., Ren, T., Yu, Y., Eaton, B.T., Xuan, H., Wang, L.F., 2004. Antibodies to SARS coronavirus in civets. *Emerg. Infect. Dis.* 10, 2244–2248.
- van Doremalen, N., Miazgowiec, K.L., Milne-Price, S., Bushmaker, T., Robertson, S., Scott, D., Kinne, J., McLellan, J.S., Zhu, J., Munster, V.J., 2014. Host species restriction of Middle East respiratory syndrome coronavirus through its receptor, dipeptidyl peptidase 4. *J. Virol.* 88, 9220–9232.
- Walls, A.C., Tortorici, M.A., Bosch, B.J., Frenz, B., Rottier, P.J.M., DiMaio, F., Rey, F.A., Veesler, D., 2016a. Cryo-electron microscopy structure of a coronavirus spike glycoprotein trimer. *Nature* 531, 114–117.
- Walls, A.C., Tortorici, M.A., Frenz, B., Snijder, J., Li, W., Rey, F.A., DiMaio, F., Bosch, B.J., Veesler, D., 2016b. Glycan shield and epitope masking of a coronavirus spike protein observed by cryo-electron microscopy. *Nat. Struct. Mol. Biol.* 23, 899–905.
- Wang, N., Shi, X., Jiang, L., Zhang, S., Wang, D., Tong, P., Guo, D., Fu, L., Cui, Y., Liu, X., Arledge, K.C., Chen, Y.H., Zhang, L., Wang, X., 2013. Structure of MERS-CoV spike receptor-binding domain complexed with human receptor DPP4. *Cell Res.* 23, 986–993.
- Wang, Q., Qi, J., Yuan, Y., Xuan, Y., Han, P., Wan, Y., Ji, W., Li, Y., Wu, Y., Wang, J., Iwamoto, A., Woo, P.C., Yuen, K.Y., Yan, J., Lu, G., Gao, G.F., 2014. Bat origins of MERS-CoV supported by bat coronavirus HKU4 usage of human receptor CD26. *Cell Host Microbe* 16, 328–337.
- Weiss, S., Yitzhaki, S., Shapira, S.C., 2015. Lessons to be learned from recent biosafety incidents in the United States. *Isr. Med. Assoc. J.* 17, 269–273.
- World Health Organization, 2004. WHO SARS Risk Assessment and Preparedness Framework. WHO Press, Geneva.
- Wu, K., Peng, G., Wilken, M., Geraghty, R.J., Li, F., 2012. Mechanisms of host receptor adaptation by severe acute respiratory syndrome coronavirus. *J. Biol. Chem.* 287, 8904–8911.
- Wu, N.C., Wilson, I.A., 2017. A perspective on the structural and functional constraints for immune evasion: insights from influenza virus. *J. Mol. Biol.* 429, 2694–2709.
- Xiong, H., Morrison, J., Ferris, M.T., Gralinski, L.E., Whitmore, A.C., Green, R., Thomas, M.J., Tisoncik-Go, J., Schroth, G.P., Pardo-Manuel de Villena, F., Baric, R.S., Heise, M.T., Peng, X., Katze, M.G., 2014. Genomic profiling of collaborative cross founder mice infected with respiratory viruses reveals novel transcripts and infection-related strain-specific gene and isoform expression. *G3 (Bethesda)* 4, 1429–1444.
- Yang, X.L., Hu, B., Wang, B., Wang, M.N., Zhang, Q., Zhang, W., Wu, L.J., Ge, X.Y., Zhang, Y.Z., Daszak, P., Wang, L.F., Shi, Z.L., 2015. Isolation and characterization of a novel bat coronavirus closely related to the Direct progenitor of severe acute respiratory syndrome Coronavirus. *J. Virol.* 90, 3253–3256.
- Yount, B., Curtis, K.M., Baric, R.S., 2000. Strategy for systematic assembly of large RNA and DNA genomes: transmissible gastroenteritis virus model. *J. Virol.* 74, 10600–10611.
- Yount, B., Curtis, K.M., Fritz, E.A., Hensley, L.E., Jahrling, P.B., Prentice, E., Denison, M.R., Geisbert, T.W., Baric, R.S., 2003. Reverse genetics with a full-length infectious cDNA of severe acute respiratory syndrome coronavirus. *Proc. Natl. Acad. Sci. USA* 100, 12995–13000.
- Yount, B., Denison, M.R., Weiss, S.R., Baric, R.S., 2002. Systematic assembly of a full-length infectious cDNA of mouse hepatitis virus strain A59. *J. Virol.* 76, 11065–11078.
- Yount, B., Roberts, R.S., Lindesmith, L., Baric, R.S., 2006. Rewiring the severe acute respiratory syndrome coronavirus (SARS-CoV) transcription circuit: engineering a recombination-resistant genome. *Proc. Natl. Acad. Sci. USA* 103, 12546–12551.
- Yuan, Y., Cao, D., Zhang, Y., Ma, J., Qi, J., Wang, Q., Lu, G., Wu, Y., Yan, J., Shi, Y., Zhang, X., Gao, G.F., 2017. Cryo-EM structures of MERS-CoV and SARS-CoV spike glycoproteins reveal the dynamic receptor binding domains. *Nat. Commun.* 8, 15092.
- Zakhartchouk, A.N., Sharon, C., Satkunarajah, M., Auperin, T., Viswanathan, S., Mutwiri, G., Petric, M., See, R.H., Brunham, R.C., Finlay, B.B., Cameron, C., Kelvin, D.J., Cochrane, A., Rini, J.M., Babik, L.A., 2007. Immunogenicity of a receptor-binding domain of SARS coronavirus spike protein in mice: implications for a subunit vaccine. *Vaccine* 25, 136–143.
- Zaki, A.M., van Boheemen, S., Bestebroer, T.M., Osterhaus, A.D., Fouchier, R.A., 2012. Isolation of a novel coronavirus from a man with pneumonia in Saudi Arabia. *N. Engl. J. Med.* 367, 1814–1820.
- Züst, R., Cervantes-Barragan, L., Habjan, M., Maier, R., Neuman, B.W., Ziebuhr, J., Szretter, K.J., Baker, S.C., Barchet, W., Diamond, M.S., Siddell, S.G., Ludewig, B., Thiel, V., 2011. Ribose 2'-O-methylation provides a molecular signature for the distinction of self and non-self mRNA dependent on the RNA sensor Mda5. *Nat. Immunol.* 12, 137–143.