



**AALBORG UNIVERSITY**  
DENMARK

**Aalborg Universitet**

## **Transformerless Inverter Topologies for Single-Phase Photovoltaic Systems**

### *A Comparative Review*

Khan, Noman; Forouzesh, Mojtaba; Siwakoti, Yam; Li, Li; Kerekes, Tamas; Blaabjerg, Frede

*Published in:*

I E E E Journal of Emerging and Selected Topics in Power Electronics

*DOI (link to publication from Publisher):*

[10.1109/JESTPE.2019.2908672](https://doi.org/10.1109/JESTPE.2019.2908672)

*Creative Commons License*

Unspecified

*Publication date:*

2020

*Document Version*

Early version, also known as pre-print

[Link to publication from Aalborg University](#)

*Citation for published version (APA):*

Khan, N., Forouzesh, M., Siwakoti, Y., Li, L., Kerekes, T., & Blaabjerg, F. (2020). Transformerless Inverter Topologies for Single-Phase Photovoltaic Systems: A Comparative Review. *I E E E Journal of Emerging and Selected Topics in Power Electronics*, 8(1), 805 - 835. [8684241].  
<https://doi.org/10.1109/JESTPE.2019.2908672>

#### **General rights**

Copyright and moral rights for the publications made accessible in the public portal are retained by the authors and/or other copyright owners and it is a condition of accessing publications that users recognise and abide by the legal requirements associated with these rights.

- Users may download and print one copy of any publication from the public portal for the purpose of private study or research.
- You may not further distribute the material or use it for any profit-making activity or commercial gain
- You may freely distribute the URL identifying the publication in the public portal -

#### **Take down policy**

If you believe that this document breaches copyright please contact us at [vbn@aub.aau.dk](mailto:vbn@aub.aau.dk) providing details, and we will remove access to the work immediately and investigate your claim.

# Transformerless Inverter Topologies for Single-Phase Photovoltaic Systems: A Comparative Review

**Abstract**— In Photovoltaic (PV) applications, a transformer is often used to provide galvanic isolation and voltage ratio transformations between input and output. However, these conventional iron and copper-based transformers increase the weight/size and cost of the inverter whilst reducing the efficiency and power density. It is therefore desirable to avoid using transformers in the inverter. However, additional care must be taken to avoid safety hazards such as ground fault currents and leakage currents, e.g. via the parasitic capacitor between the PV panel and ground. Consequently, the grid connected transformerless PV inverters must comply with strict safety standards such as IEEE 1547.1, VDE0126-1-1, EN 50106, IEC61727, and AS/NZS 5033.

Various transformerless inverters have been proposed recently to eliminate the leakage current using different techniques such as decoupling the DC from AC side and/or clamping the common mode (CM) voltage during the freewheeling period, or using common ground configurations. The permutations and combinations of various decoupling techniques with integrated voltage buck-boost for maximum power point tracking (MPPT) allow numerous new topologies and configurations, which are often confusing and difficult to follow to select the right topology. Therefore, to present a clear picture on the development of transformerless inverters for the next generation grid-connected PV systems, this paper aims to comprehensively review and classify various transformerless inverters with detailed analytical comparisons. To reinforce the findings and comparisons as well as to give more insight on the CM characteristics and leakage current, computer simulations of major transformerless inverter topologies has been performed in PLECS software. Moreover, the cost and size are analysed properly and summarized in a table. Finally, efficiency and thermal analysis are provided with a general summary as well as technology roadmap.

**Index Terms**— Photovoltaic (PV) system, transformerless inverter, grid-connected inverter, common-mode voltage (CMV), leakage current, AC-decoupling, DC-decoupling.

## I. INTRODUCTION

Solar photovoltaic (PV) is one of the cleanest, readily and widely available energy sources among all renewable energies [1]. With the technological advancement in material and manufacturing techniques, the cost of PV system is continuously reduced, making it the cheapest energy source for future massive deployment. Many countries (USA, Germany, China, Japan, Australia, France, Italy, Spain, etc.) have already begun to reap the benefits through their increased adoption and integration to the utility grid. According to the annual report from International Energy Agency-Photovoltaic Power Systems Program (IEA-PVPS) [2], the global installed PV capacity reached 100 GW milestone in 2012, and 200 GW level in 2015. By the end of 2017, the total installed PV capacity is estimated to be roughly 410 GW, while 24 IEA-PVPS countries reached 264 GW [2]. Fig. 1 shows the cumulative installed PV capacity of the top IEA-PVPS countries from 2012 to 2017. From this figure, it

is evident that the PV industry is facing rapid growth, in which five leading countries are representing 90.1% of all PV installations in 2017. Among them, China, USA, and Japan experienced the largest PV installations increment in recent years.

Among all PV installations, the percentage of off-grid PV systems is very low [3]. The grid-connected PV systems need power inverters as an interface between the PV panel and the grid, which are generally categorized as the galvanic isolated inverter and non-isolated inverter. In the isolated type, usually a high-frequency DC side transformer or a low-frequency AC side transformer is used to achieve galvanic isolation, which enhances the system safety. Due to their lower cost, size/weight, and higher efficiency, transformerless inverters are of much interest for the low to medium power residential market [4-8].

Fig. 2 illustrates a general layout for a single-phase transformerless inverter for small-scale PV systems. As it can be seen, without a galvanic isolation, a direct ground-current path can be formed between the PV panel and the grid. Due to the presence of large stray capacitance ( $C_{pv}$ ) between the PV and grid grounds, the varying voltage (also known as common-mode (CM) voltage) can excite resonant circuit formed by the parasitic capacitor and inverter filter inductor, which produces high CM ground current  $i_{cm}$ . This capacitive  $i_{cm}$  comprises line low-frequency and switching high-frequency components, which injects harmonics into the grid current, increases the system losses, impairs electromagnetic compatibility, and may also cause safety problems such as electric shock [9]-[15].

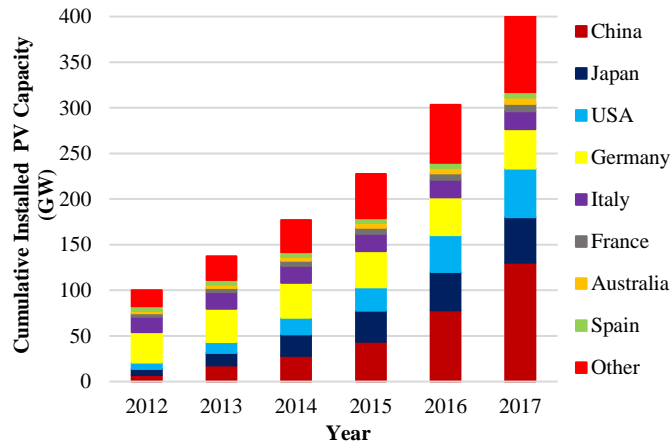

Fig. 1. Cumulative PV installations for the top IEA-PVPS countries from 2012 to 2017 [2].

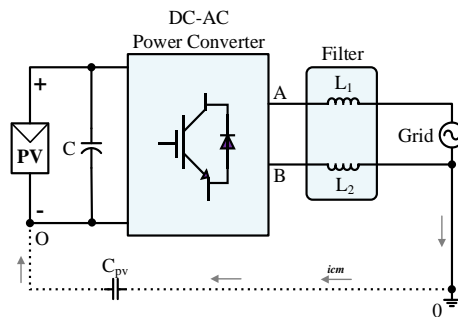

Fig. 2. The general layout of a single-phase transformerless inverter using an L-filter.

In order to understand the grid-connected PV systems to satisfy various grid codes and their safety standards, numerous inverter related issues have been thoroughly investigated [16]-[28]. So far, many transformerless inverter topologies have been

presented with the aim to eliminate the leakage current. To achieve that, various decoupling techniques have been adopted, such as, decoupling the DC from AC side [29]-[36] and/or clamping the common mode voltage (CMV) during the freewheeling period [9], [10], and [37]-[41], or using common ground configurations [5], [12], [16], and [42]-[45]. The combinations of these decoupling techniques with integrated MPPT circuits form an immense number of topologies and configurations, which are often confusing and difficult to follow. Therefore, to present a clear picture on the development of the transformerless inverter for the next generation grid-connected PV systems, this paper aims to review and classify various transformerless inverters. Further, it aims to provide an analytical overview and analysis of well-known single-phase transformerless inverter topologies as well as comparing the transformerless inverters based on the loss and efficiency analysis through detailed calculations. This categorisation and analysis can help researchers to understand the advantages and disadvantages of various transformerless inverter topologies in terms of their CMV and leakage current behaviour.

The rest of this paper is organized as follows. The main grid requirements and problems related to transformerless PV inverters are discussed in Section II. A broad classification of different single-phase transformerless inverter topologies is presented in Section III including simulation results of CM voltage and current using PLECS software. In Section IV, loss and efficiency calculations are presented for some of the major transformerless inverter topologies and the results are finally summarised and concluded in Section V.

## II. REQUIREMENTS AND ISSUES OF TRANSFORMERLESS PV INVERTERS

Grid-connected PV systems need special attention in order to satisfy grid codes and standards. Hence, international agencies have regulated some broadly accepted standards for PV systems, which are required in end to avoid safety issues. The major culprit behind these safety issues and concerns is the presence of the ground capacitance  $C_{PV}$  between the PV cells/panel and the ground as illustrated in Fig. 3. PV panels are comprised of the combination of glass, Ethylene-Vinyl Acetate (EVA), back sheet (Tedlar), and aluminium frame, in which  $C_{PV}$  is created from the PV cell to the frame, to the rack, and the ground. Moreover, in the transformerless PV inverter, a CM resonant circuit can be created between the parasitic capacitor of PV module and output filter inductors at the grid side, which can cause severe problems such as high ground current  $i_{cm}$  and its subsequent problems [7], [46]. Furthermore, the output filter, which forms a resonant circuit with the power switching circuit, has a major role in ground leakage current. This is very important to understand the CM behaviour of the transformerless system. The following sub-sections provide a brief explanation on the CM behaviour of the circuit and its ground leakage current, followed by different grid codes as well as safety requirements.

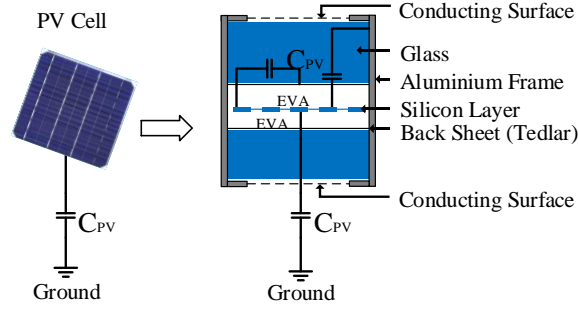

Fig. 3. Parasitic capacitance in PV panels [46].

### A. Common-Mode Resonant Circuit and Leakage Current Issues

The amplitude and spectrum of leakage current depend mainly on the converter circuit topology, modulation strategy and the resonant circuit formed by the ground capacitor, the converter, the output AC filter and the grid. Fig. 4(a) shows the CM equivalent circuit of the inverter, which comprises the converter, filter inductors ( $L_1$ ,  $L_2$ ), and parasitic capacitor ( $C_{pv}$ ). The power circuit in Fig. 4(a) can be replaced with phase voltages of the inverter  $V_{AO}$  and  $V_{BO}$ , which are equal to the potential of A and B points relative to the neural point O (see Fig. 4(b)) [29], and [47]-[48]. The CMV and differential-mode voltage (DMV) can be written based on the phase voltages as follows:

$$V_{cm} = \frac{V_{AO} + V_{BO}}{2} \quad (1)$$

$$V_{DM} = V_{AO} - V_{BO} \quad (2)$$

Moreover, the phase voltages can be expressed based on  $V_{cm}$  and  $V_{DM}$  as mentioned in (3) and (4).

$$V_{AO} = V_{cm} + \frac{V_{DM}}{2} \quad (3)$$

$$V_{BO} = V_{cm} - \frac{V_{DM}}{2} \quad (4)$$

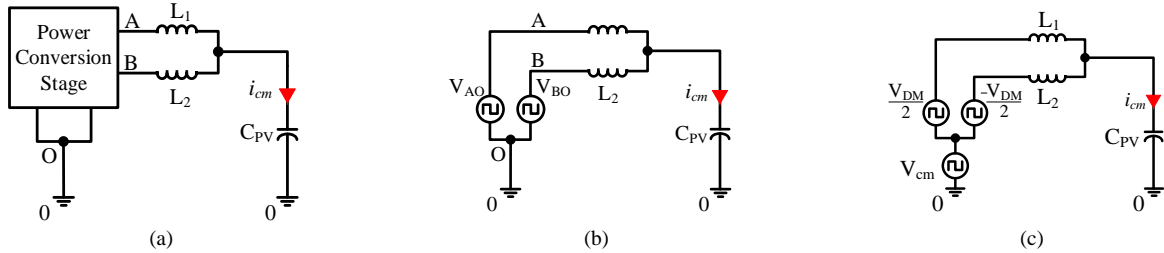

Fig. 4. CM model showing (a) the resonant circuit, and (b) the resonant circuit including  $V_{AO}$  and  $V_{BO}$ .

To better understand the CM behaviour, the equivalent circuit can be simplified into a single loop circuit as shown in Fig.

5(a). The equivalent CMV ( $V_{ECM}$ ) shown in this figure can be obtained as

$$V_{ECM} = V_{cm} + \frac{V_{DM}}{2} \frac{L_2 - L_1}{L_1 + L_2} \quad (5)$$

The magnitude of  $i_{cm}$  depends mainly on the amount of parasitic capacitance and the amplitude and frequency of the CMV, whose fluctuation can produce a large  $i_{cm}$ . To avoid the leakage current  $i_{cm}$ , (5) should be equal to zero, which is dependent on the circuit topology. Moreover, the equivalent CMV has to remain constant in each switching period in order to reduce  $i_{cm}$ . The effect of DMV can be eliminated in symmetrical topologies like H-bridge inverter by using two identical

inductor filter at the output (i.e.,  $L_1 = L_2$ ) [29], and [47]-[49]. The simplified equivalent CM circuit including the equivalent impedance ( $Z_{EQU}$ ) is shown in Fig. 5(b). This circuit can be demonstrated in the  $s$ -domain to analyse the frequency and magnitude of the created resonant circuit (see Fig. 5(c)) [10]. Letting  $L_1 = L_2$  in (5) for the topologies with a symmetrical structure (e.g. H-bridge), the equivalent CMV can be replaced with  $V_{cm}$ . The transfer function from  $i_{cm}$  to CMV created by the converter through the resonant circuit can be expressed as (7).

$$V_{ECM}(s) - \left( Ls + \frac{1}{sC_{PV}} \right) i_{cm}(s) = 0 \quad (6)$$

$$H(s) = \frac{i_{cm}(s)}{V_{ECM}(s)} = \frac{s}{Ls^2 + \frac{1}{C_{PV}}} \quad (7)$$

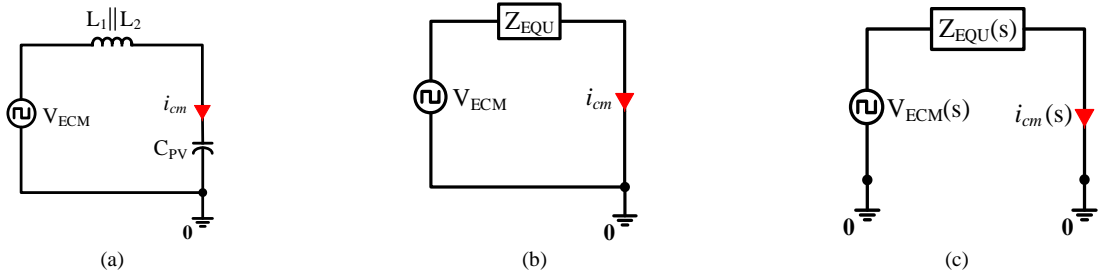

Fig. 5. Simplified single loop CM model, (a) considering the series connection of components, (b) the equivalent impedance circuit, and (c) the  $s$ -domain equivalent circuit.

In (6) and (7),  $L = (L_1 L_2) / (L_1 + L_2)$ . Fig. 6 illustrates the Bode plot of the transfer function in (7) considering  $L_1 = L_2 = 3$  mH and  $C_{PV} = 75$  nF.

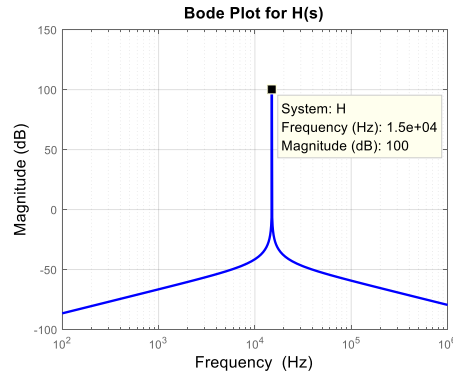

Fig. 6. Bode plot of the resonant circuit model in Fig. 5.

It is evident that the resonant frequency equals 15 kHz. Moreover, as the filter inductor and parasitic capacitor forms a typical LC resonant circuit, its resonant frequency can be calculated theoretically from (8). Both the simulation and analytical results show the same resonant frequency, with which a large CM current  $i_{cm}$  flows into the system.

$$f_r = \frac{1}{2\pi\sqrt{LC_{PV}}} = 15005 \text{ Hz} \quad (8)$$

Without a galvanic isolation, the potential between the PV array and the ground ( $V_{ECM}$ ) fluctuates, which charges and discharges the parasitic capacitor ( $C_{PV}$ ). This fluctuating CMV activates the resonant circuit as discussed above and may lead to higher ground leakage current. However, the resonant frequency is not fixed, as it depends on the parasitic capacitance

together with the DC lines that connects the PV array to the inverter. It also depends on the size of the PV array and the environmental conditions. All these conditions make the elimination of leakage current more difficult in practice [50].

### B. Grid Requirements and Standards

Grid-connected PV systems should comply with different standards that are regulated internationally and by each country.

In this subsection, a brief overview on different grid codes is given for grid-connected PV systems, while a more detailed study can be found in [51]. Table I illustrates important required grid codes regulated by major countries and associations.

TABLE I  
GRID CONNECTED PV SYSTEM STANDARDS AND GRID CODES [17]-[24], [28], [52]-[54].

Standard No.	Publication Origin	THD	DC Current Injected	Grid Frequency ( $f_g$ ) Range (Hz)	Power Factor
IEEE 1547 [17]	USA (IEEE)	Less than 5%	<0.5% of rated output current	57 ~ 60.5	0.9 to 0.97
IEEE 929-2000 [20]	USA (IEEE)	Less than 5%	<0.5% of rated output current	59.3 ~ 60.5	> 0.85
IEC 61727 [28]	Swiss (IEC)	Less than 5%	< 1% of rated output current	49 ~ 51	> 0.90
AS4777 [52]-[54]	Australia	Less than 5%	0.5% of rated output current per phase	48 ~ 52	0.8 to 0.95
EN 61000-3-2 [22]	England	Less than 5%	< 0.22A corresponding to a 50 W half-wave rectifier	47.5 ~ 50.2	NA
EREC G83 [21]	England	Less than 5%	0.25 % of AC current rating per phase	49 ~ 51	0.95
VDE 4105 [18]	Germany	Less than 5%	< 1 A; max. trip time 0.2 s	47.5 ~ 51.5	0.89 to 0.95
BDEW [23]	Germany	Less than 5%	NA	47.5 ~ 51.5 (-5% ~ +3%)	0.95
GB/T 19964-2012 [24]	China	Less than 5%	< 1% of rated output current	48-50.5	0.95
JEAC 9701-2012 [25]	Japan	Less than 5%	NA	47.5 ~ 51.5 (Eastern Japan) 57 ~ 61.8 (Western Japan)	0.9 to 0.95

When a PV panel is connected to the grid, different parameters need to be taken care of to have acceptable performance. The major ones are as follows: total harmonic distortion (THD), injected DC current, grid frequency ( $f_g$ ) range, power factor and  $i_{cm}$  range. In most PV standards, the maximum allowable THD of the output current is limited to 5% which is the reason for having improved power quality at distribution feeders. On the other hand, the amounts of injected DC current to PV system is invariably limited to be within 0.22% - 1% of the rated output current. This current is difficult to measure precisely with the existing inverter circuits. The range of grid frequency is mentioned in Table I for different standards. However, the standard frequency range may fluctuate more for different abnormal conditions [17]-[25], [27].

TABLE II  
LEAKAGE CURRENT WITH DISCONTINUITY TIME IN VDE 0126-1-1.

Leakage Current (mA)	Fault Discontinuity time (ms)
30	300
60	150
100	40

VDE 0126-1-1 specifies the acceptable range of  $i_{cm}$  that should not be more than 100 mA when the fault discontinuity time is not more than 40 ms [55]-[56] as shown in Table II. Grid-connected systems must follow active and passive anti-islanding requirements due to the fluctuating voltage and frequency range according to IEEE 929-2000, IEEE-1547, VDE-AR-N 4105, and IEC 61727 standards [17]-[19], and [27] and most of the standards follow a limit of voltage variations between 3% and 5% [19]-[21], [25]. On the other hand, voltage fluctuation must be kept within  $\pm 5\%$  for standard IEEE 1547 [17].

### III. CLASSIFICATION OF SINGLE-PHASE TRANSFORMERLESS INVERTER TOPOLOGIES

Voltage source inverters (VSIs) are favourable for PV applications due to cost, efficiency, and size over current source inverters (CSIs), and numerous voltage source single-phase transformerless topologies have been proposed and developed for

grid-connected PV systems to improve the performance and compatibility to grid codes [5], [7], [9], [12], [14], [15], [29], and [31]-[72]. Fig. 7 illustrates a classification of some of the important topologies in two major sub-groups based on the requirement for the DC-link voltage to achieve 240 Vac with 50 Hz grid frequency, i.e., DC link voltage ( $2 \times V_{PV}$ ) and DC link voltage ( $V_{PV}$ ) based single-phase transformerless inverters. Moreover, the single-input group can be categorized into five subgroups, based on  $i_{cm}$  suppression, decoupling and voltage clamping, i.e., common ground, H-bridge, H6, and buck-boost type topologies.

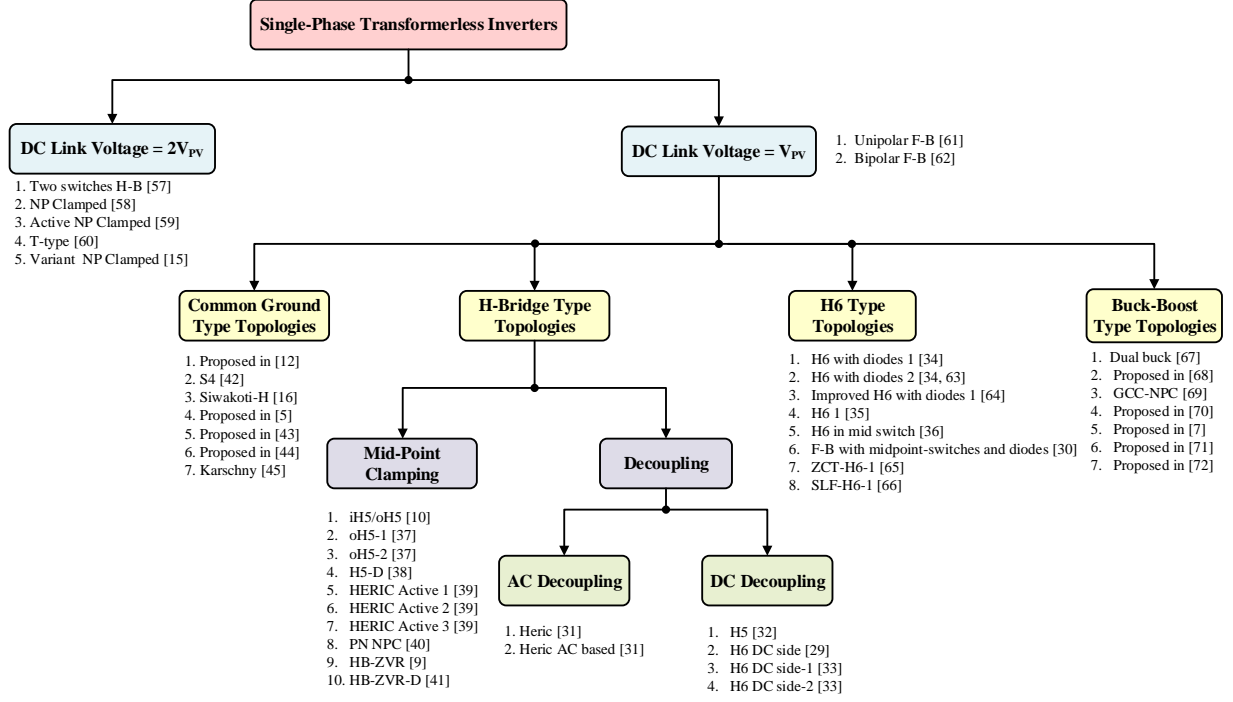

Fig. 7. Classification of single-phase transformerless inverter topologies used in PV systems according to DC-link voltage.

TABLE III  
PARAMETERS USED FOR SIMULATIONS AND COMPARISONS.

Parameter	Value
Input Voltage ( $V_{PV}$ )	400 V <sub>DC</sub>
Output Load	32 $\Omega$
Output Voltage ( $V_g$ )	240 V <sub>ac</sub>
Line Frequency ( $f_g$ )	50 Hz
Output Current ( $i_g$ )	7.35 A
Modulation Index (M)	0.82
Rated Power	1800 kVA
Switching Frequency ( $f_{sw}$ )	20 kHz
DC Bus Capacitor ( $C = 2 \times C_1$ ) & ( $C_1 = C_2$ )	1600 $\mu$ F
Flying Capacitor ( $C_F$ )	470 $\mu$ F
Flying Inductor ( $L_m$ )	0.3 mH
Filter Capacitor ( $C_o$ )	2.2 $\mu$ F
Filter Inductor ( $L_1, L_2$ )	3 mH
Parasitic Capacitor ( $C_{pv1}, C_{pv2}$ )	75 nF
Switches (IKW30N60DTP)	$V_{CE} = 600$ V, $I_C = 30$ A
Diodes (APT15D60B)	$V_F = 600$ V, $I_F = 32$ A

To shed more light on each topology considering the leakage current and CMV, the following sections provide analysis and simulation of some major topologies illustrating the key waveforms and CMV behaviour. Table III shows the parameters and values used for the simulations performed in this section and to benchmark the topologies. The voltage and current levels for the selected switches and diodes are 600 V and ~30 A, respectively. Moreover, all the components are chosen such that the



best performance can be achieved. The inverters are operated for 1.8 kVA where the input voltage is selected as  $400 V_{DC}$  to obtain  $230 V_{ac}$  and the output current is achieved as  $\sim 7.35$  A (RMS) [9], [35], [39], and [41].

### A. Double Input Voltage ( $2V_{PV}$ ) Type Single-Phase Transformerless Inverter Topologies

In this section, five single-inductor based transformerless inverters are introduced, where either  $L_1 = 0$  or  $L_2 = 0$  and the parasitic capacitance is 75 nF. The operational modes of each topology is discussed, as well as switching pulses and the output current describing the CM effect.

Two-switch based half-bridge (H-B) inverter works by alternatively switching pulses as shown in Fig. 8 (b), and the input voltage operates by charging and discharging the DC link capacitors ( $C_1$  and  $C_2$ ) (see Fig. 8 (a)) [73], which are shown to be more difficult to achieve the maximum power point of PV panel. Hence, the output current ripple is increased. To simplify the control system and improve the efficiency and current ripple, compared to two-switch based H-B [74], and [75], a new topology was introduced by A. Nabae, et al in 1981 [58] called the neutral point clamped (NPC), which is also well known for minimizing the cost and size of the filter. This topology operates with three voltage levels [76], and [77]. The zero voltage stage can be achieved by the clamping technique through the clamp diodes of the midpoint, which is shown by the schematic diagram (see Fig. 9 (a)), and the modulation pulses are illustrated in Fig. 9 (b). However, the main negative part of this topology is unbalanced conduction losses and a restricted DC link balance [78], which affects the whole system.

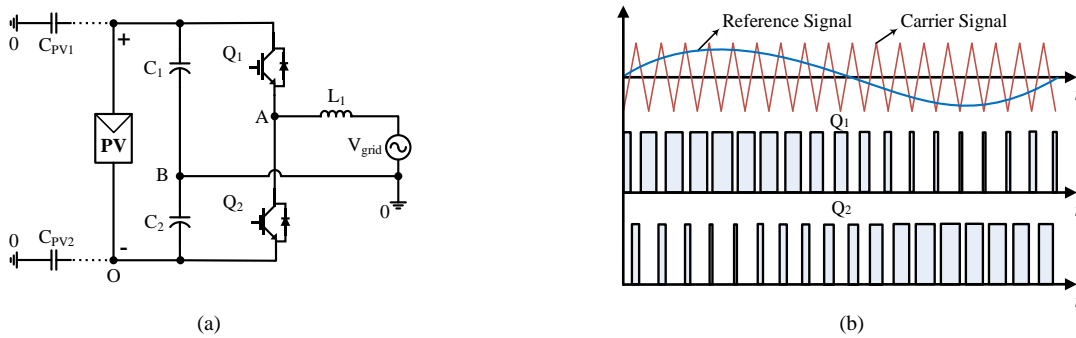

Fig. 8. Illustration of (a) two switches H-B inverter, and (b) its switching pulses.

The active NPC (ANPC) is illustrated in Fig. 10 (a) which is modified from the conventional NPC topologies [44], [79], and [80] and mitigates the limitation of NPC topology. In this topology, two switches  $Q_5$  and  $Q_6$  are used to replace  $D_1$  and  $D_2$  diodes of the NPC. The upper clamping occurs when tuning on the switches  $Q_2$  and  $Q_5$ , whereas the lower clamped works when  $Q_3$  and  $Q_6$  are operated [77]. After replacing the diodes with switches, the conduction losses can be controlled [54]. Fig. 10 (b) demonstrates the six switching pulses.

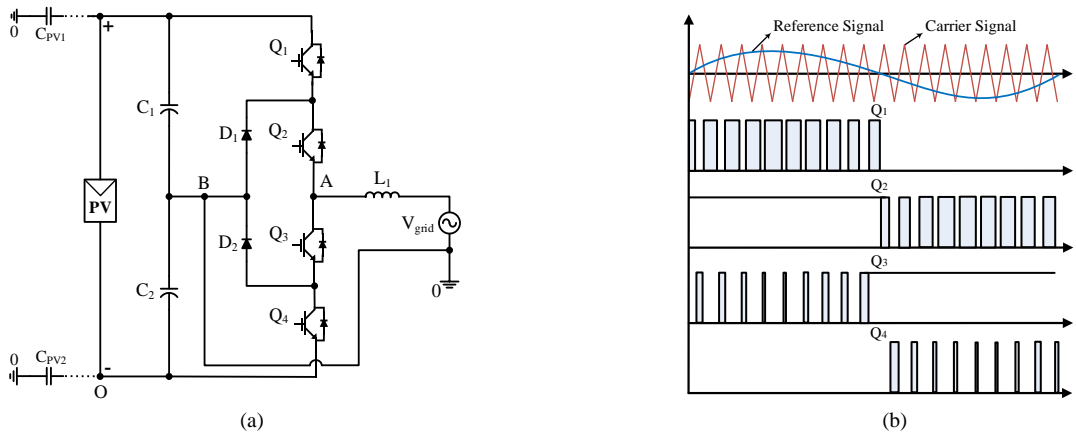

Fig. 9. Illustration of (a) NPC H-B inverter, and (b) its switching pulses.

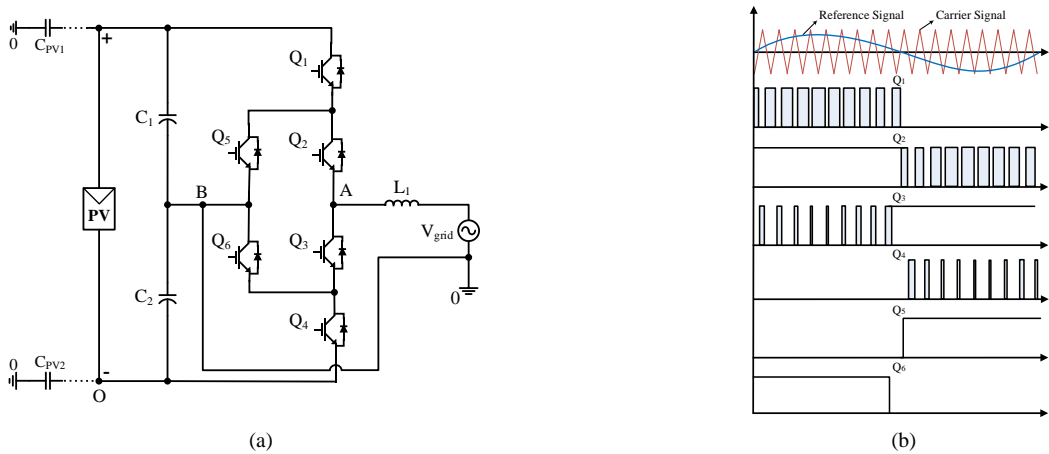

Fig. 10. Illustration of (a) ANPC H-B, and (b) its switching pulses.

To reduce PV more conduction losses, the transistor (T)-type shown in Fig.11 (a) is a good solution with bidirectional switches which are inserted between the middle points of the DC-link capacitors and  $Q_1$ - $Q_2$  branch [78], [81], and [82]. The switching pulses are presented in Fig. 11 (b) showing that the switches  $Q_1$  and  $Q_3$  work in complement with switches  $Q_2$  and  $Q_4$  accordingly [83]. Moreover, the switching combination of the four switches are different where the midpoint clamping switches ( $Q_3$  and  $Q_4$ ) are selected for low switching losses and low forward voltage drops [78].

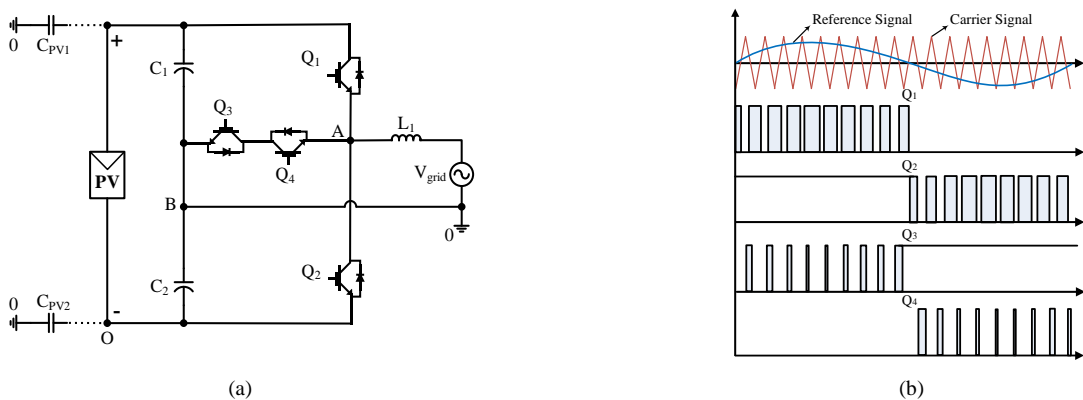

Fig. 11. Illustration of (a) T-type H-B inverter, and (b) its switching pulses

The T-type, NPC and ANPC topologies are also well known in five-level inverters for improving the power quality and reducing the complexity in high power applications [84]-[87]. It can help to obtain a high conversion efficiency with low switching losses [87]- [89].

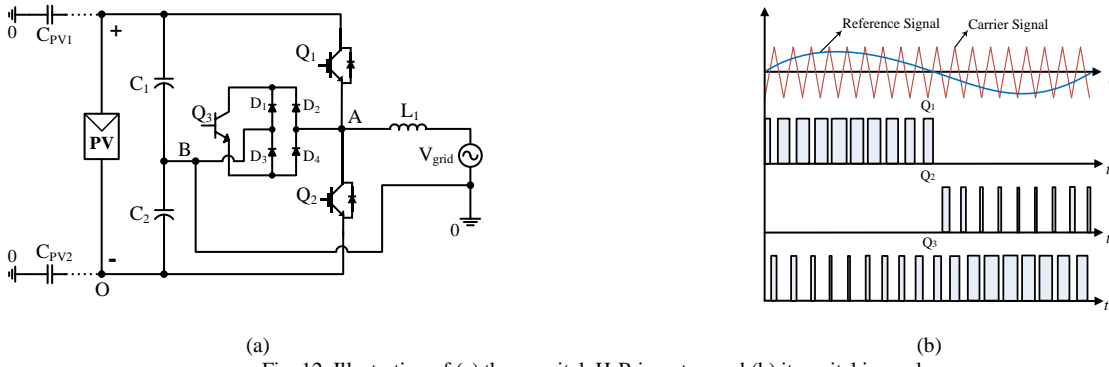

Fig. 12. Illustration of (a) three-switch H-B inverter, and (b) its switching pulses.

A variant of the NPC is introduced in Fig. 12(a) [15] to reduce the number of switches of NPC/ANPC topologies. This topology uses a diode bridge with a bidirectional switch  $Q_3$ . The diodes are used for providing a current path during the null states, and the concept of a bidirectional switch is taken from Conergy topology [83] by combining two bidirectional switches to one. The variant NPC topology operates in four operational modes. In the positive half cycle, only  $Q_1$  is in ON condition, whereas in the negative half cycle,  $Q_2$  is ON. In the freewheeling time of the positive half cycle,  $D_1$  and  $D_4$  are in forward bias mode with the switch  $Q_3$ ; and in the negative cycle, the other two switches  $D_2$  and  $D_3$  are ON with the switch  $Q_3$  [50]. Fig. 12(b) shows different switching pulses of the variant NPC.

TABLE IV  
SUMMARY OF THE DOUBLE INPUT VOLTAGE TYPE TRANSFORMERLESS INVERTERS.

Topology name	Semiconductor Devices				$i_{cm}$ (mA)	Passive Filter Component		Voltage Level
	IGBTs		Diodes			No. of Inductor (L)	No. of Capacitor (C)	
	No.	Voltage	No.	Voltage				
Two-Switches based	2	$1.5 \times V_{pv}$	0	---	$\leq 2$	1	0	2
NPC	4	$1.5 \times V_{pv}$	2	$1.5 \times V_{pv}$	$\leq 3.5$	1	0	3
ANPC	6	$1.5 \times V_{pv}$	0	---	$\leq 2.5$	1	0	3
T-type	4	$1.5 \times V_{pv}$	0	---	$\leq 4$	1	0	3
Variant NPC	3	$1.5 \times V_{pv}$	4	$1.5 \times V_{pv}$	$\leq 4.2$	1	0	3

The simulation results of the above topologies are shown in Fig 13 (a) to Fig. 13(e) where the input voltage is selected as  $2 \times V_{pv}$ , and  $L_1 = 3$  mH. Table IV indicates the overall summary of the double-input voltage transformerless inverter topologies.

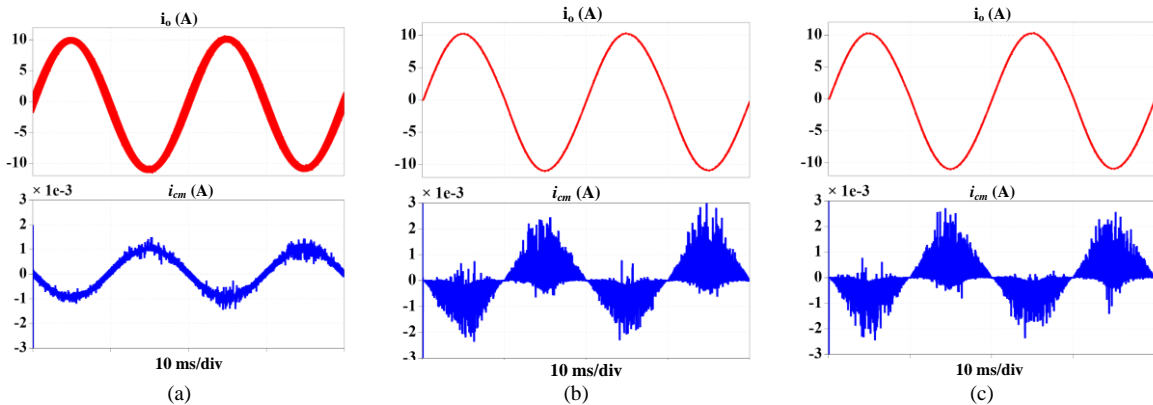

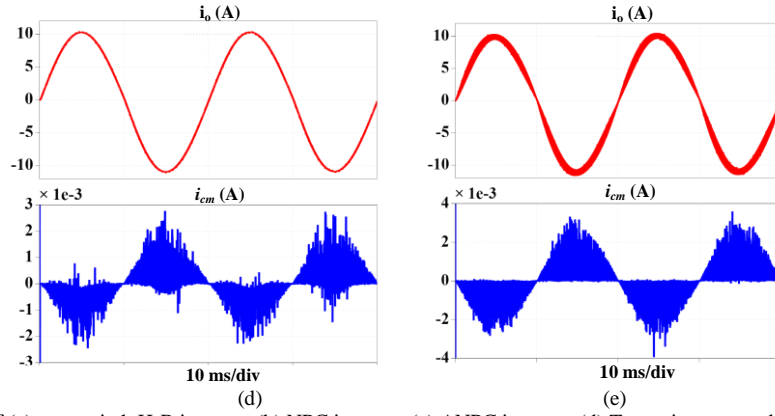

Fig. 13. Simulation results of (a) two-switch H-B inverter, (b) NPC inverter, (c) ANPC inverter, (d) T-type inverter and (e) variant NPC inverter.

### B. Single-Input Voltage ( $V_{PV}$ ) Type Single-Phase Transformerless Inverter Topologies

Full-bridge (FB) single-phase transformerless inverter topologies with both bipolar and unipolar switching pattern [61] are explained in this section. Conventional FB inverter with a bipolar configuration has been used for achieving constant CMV, and low  $i_{cm}$ . However, the loss increases which leads to a reduced system efficiency [90]. Hence, unipolar has been introduced for overcoming the efficiency issue [62]. In this section, bipolar and unipolar based FB inverters are shown in details and with the appropriate wave forms. Furthermore, the other single-input transformerless inverters are categorized in Fig. 7 and discussed with the simulated waveforms of  $i_{cm}$ , output voltage/current, CMV and the voltage of neutral (O) to points A and B. Table IV tabulates the parameter values used for the simulations.

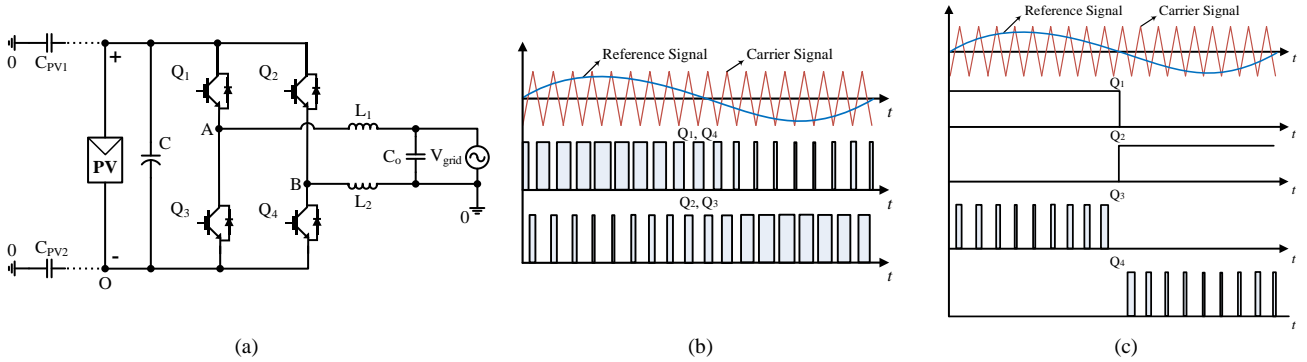

Fig. 14. Illustration of (a) Full Bridge inverter, (b) its bipolar switching pulses, and (c) its unipolar switching pulses.

Fig.14 (a) illustrates the circuit configuration of the F-B transformerless inverter topology with the parasitic capacitors on both sides of the PV panel. Bipolar switching pattern is used as shown in Fig. 14 (b). Switches  $Q_1$  and  $Q_4$  are turned ON for the positive half cycle, and the output current flows through the antiparallel diode of  $Q_2$  and  $Q_4$  to the load. On the other hand, Fig. 14 (c) shows the switching modulation for unipolar operation. In this modulation scheme,  $Q_2$  is complimentary to  $Q_1$ , and  $Q_3$  complimentary to  $Q_4$ . For the positive half cycle,  $Q_1$  and  $Q_4$  are ON, and hence, the output voltage is equal to the input voltage. During the freewheeling period, the output current flows through  $Q_1$  and antiparallel diode of  $Q_2$  for the positive half cycle; and for the negative half cycle, the output current flows through  $Q_3$  and antiparallel diode of  $Q_4$ .

The output voltage and current of the bipolar FB inverter are shown in Fig. 15 (a). The CM current is low and the CMV is constant. However, the output current ripple is high, which increase the size of the output filter. Moreover, the energy conversion efficiency is decreased significantly. On the other hand, the leakage current is very high when an FB inverter is

operated for unipolar switching pattern due to the occurrence of active and zero state in every pulse width modulation (PWM) cycle. Hence, the CMV varies from 200 V to 400 V with the switching frequency (see Fig. 15 (b)). However, the energy conversion efficiency is increased compared to the bipolar modulation due to the reduced output ripple and optimized freewheeling path of the unipolar PWM strategy.

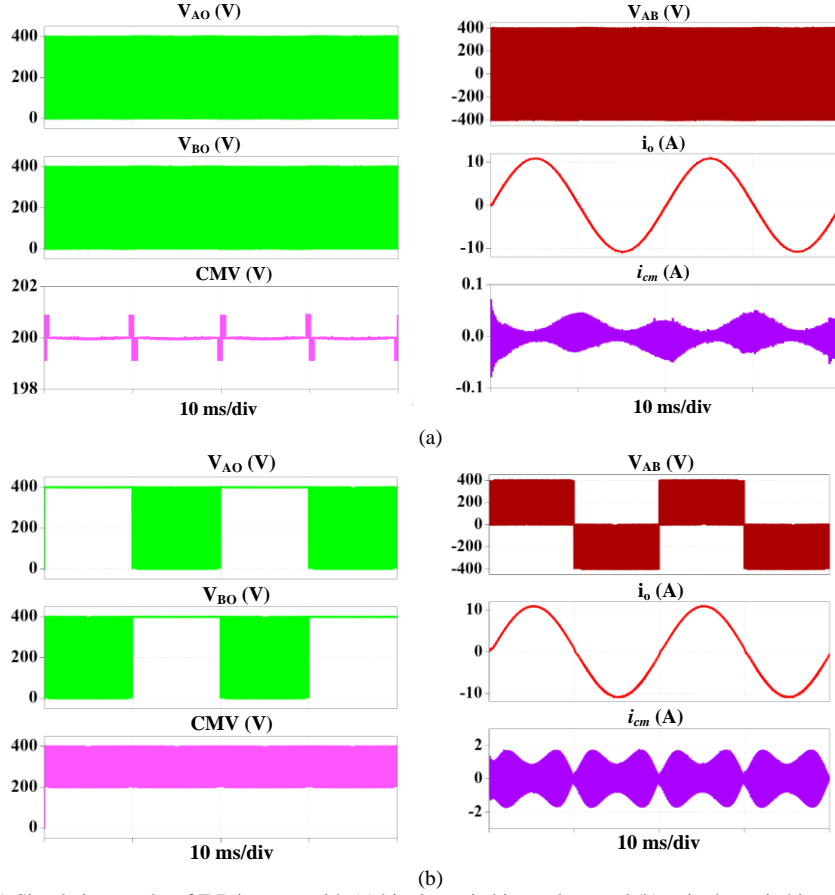

Fig. 15. Simulation results of F-B inverter with (a) bipolar switching pulses, and (b) unipolar switching pulses.

### 1) Common Ground Type Topologies

The topology where the negative polarity of the PV panel is directly connected with the grid is called common ground type topology, such as, S4 [42], Siwakoti-H [16], and those in [12], [5], [44]. The significant advantage of such kind of topologies is the constant CMV and the elimination of  $i_{cm}$ .

#### a) Inverter Topology in [12]

The topology presented in [12] is the concept of a virtual DC bus. The purpose of this technique is to generate the negative output voltage, which is necessary for the operation as an inverter. Hence, the grid neutral line (O) is directly connected with the negative pole of the PV panel, and therefore, the parasitic capacitors ( $C_{pv1}$  and  $C_{pv2}$ ) are clamped to the zero potential of the neutral, theoretically resulting in zero  $i_{cm}$ . The circuit structure is given in Fig. 16 (a) with the modulating switching pulses in Fig. 16 (b). During the positive half cycle, the switches  $Q_1$  and  $Q_3$  are always ON, and  $Q_2$  is always OFF. In the negative half cycle,  $Q_5$  is always ON, and  $Q_4$  is always OFF. The main challenging part of this topology is to control the virtual DC bus capacitor ( $C_s$ ) along with the real bus in every switching frequency ( $f_{sw}$ ).

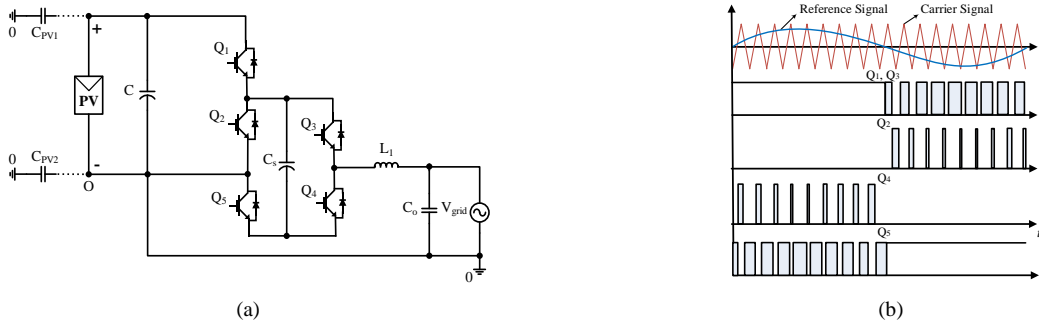

Fig. 16. Illustration of (a) inverter topology in [11], and (b) its switching pulses.

**b) S4 Topology**

The S4 topology is demonstrated in [42], [91] as shown in Fig. 17 (a). To operate the inverter, sinusoidal PWM (SPWM) is used to minimize the switching losses and to reduce the filter requirement, as shown in Fig. 17 (b). During the positive half cycle, the switches  $Q_1$  and  $Q_3$  are ON with the switching frequency to produce positive and zero voltage, while  $Q_2$  is OFF in the whole period. Hence, the output voltage of  $+V_{DC}$  is achieved. In this period, the diode  $D_1$  is OFF while the capacitor  $C_1$  is charging with  $D_2$ . On the other hand, the voltage across the capacitor  $C_2$  is constant as like the switched capacitor characteristic. To generate the negative voltage for the utility grid, the capacitor  $C_2$  is charged by the capacitor  $C_1$  with negative polarities up to  $-V_{DC}$ . However, the two-stage charge transfer process ( $V_{in}$  to  $C_1$  and  $C_1$  to  $C_2$ ) increases the number of power components and also the losses in the system.

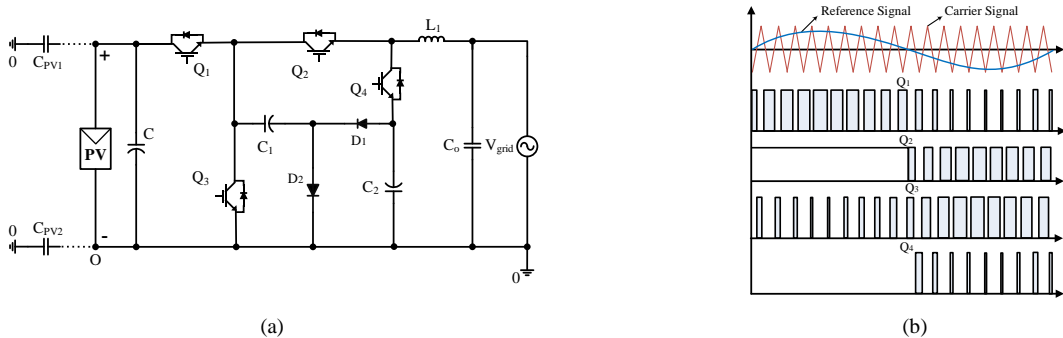

Fig. 17. Illustration of (a) S4 inverter, and (b) its switching pulses [42].

**c) Siwakoti-H**

The number of semiconductor components is significantly reduced in the topology proposed in [16], where only four switches are used. Constructed like an H-bridge shown in Fig. 18 (a), the inverter uses a flying capacitor to create a negative bus voltage for the inverter during the negative cycle. Fig. 18 (b) illustrates the switching pulses. The switches ( $Q_1$  and  $Q_4$ ) experience bipolar voltage stress, which is equal to  $\pm V_{DC}$ . Thus, bipolar voltage blocking capability switches such as the

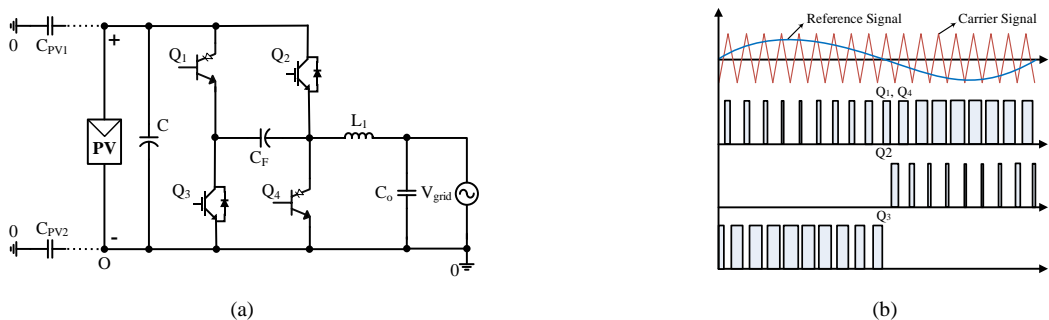

Fig. 18. Illustration of (a) Siwakoti-H inverter, and (b) its switching pulses [16].

Reverse Blocking (RB) switches are needed (e.g. RB-IGBT). On the other hand, the other two switches ( $Q_2$  and  $Q_3$ ) are capable of producing the voltage stress of  $2V_{DC}$ . During the positive half cycle, only  $Q_2$  is connected to produce the positive voltage, and  $Q_3$  is ON for the negative half cycle to produce the negative voltage. The other two switches are used for zero states.

**d) Flying Capacitor Topologies in [5], and [43]**

Flying capacitor concept can be used in common ground transformerless inverter topologies as it is presented in [5], and [43]. The first one of these two new topologies is proposed by Siwakoti in [5], the second one is proposed by Chen in [43], which are shown in Fig. 19 (a) and Fig. 19 (b), respectively. Both topologies operate with the same modulation pulses (see Fig. 19 (c)). The same concept (negative polarity of PV panel is directly connected to the grid) is used to get zero  $i_{cm}$ . For instance, the switch  $Q_1$  and diode charge the flying capacitor, and the discharging path is through switches  $Q_2$  and  $Q_4$ , which creates the negative polarity. The flying capacitor ( $C_F$ ) is charged from the input voltage, and the constant output voltage which is equal to the input voltage as like voltage converter integrated circuit, e.g., Maxim-ICL7660 and Texas Instrument-LMC7660. The circuit schematic in Fig. 19 (b) is quite similar to the one shown in [43], with only changing the device position. The switch  $Q_3$  carries the load current during the positive active cycle and the negative half cycle;  $Q_2$  and  $Q_4$  carry the load current where  $Q_2$  creates a negative power cycle by discharging the flying capacitor ( $C_F$ ) through  $Q_4$ . All the switches work under the switching frequency ( $f_{sw}$ ) with standard unipolar SPWM.

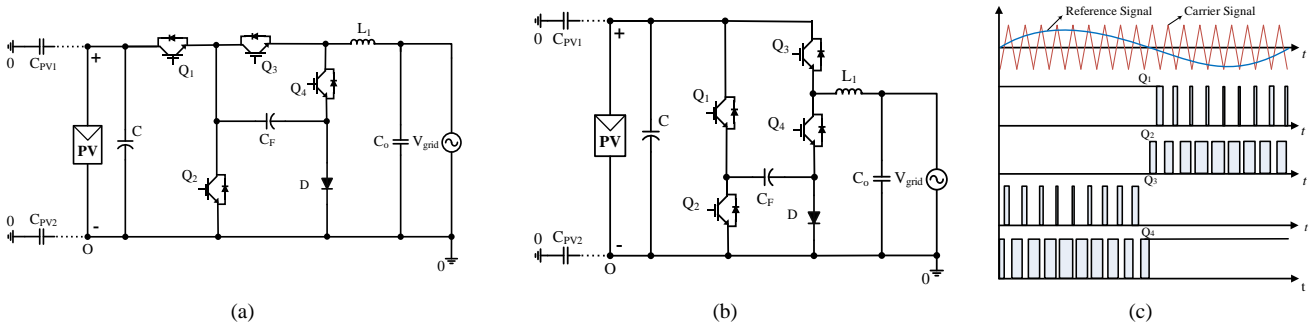

Fig. 19. Illustration of (a) inverter topology in [46], (b) inverter topology in [5], and (c) their switching pulses.

**e) Flying-inductor inverter**

The topology proposed in [44] is a five-switch based diode-less topology. Using a flying inductor ( $L_m$ ) with low inductance helps to boost the input DC voltage with power injection from the PV panel to the grid [44]-[45].

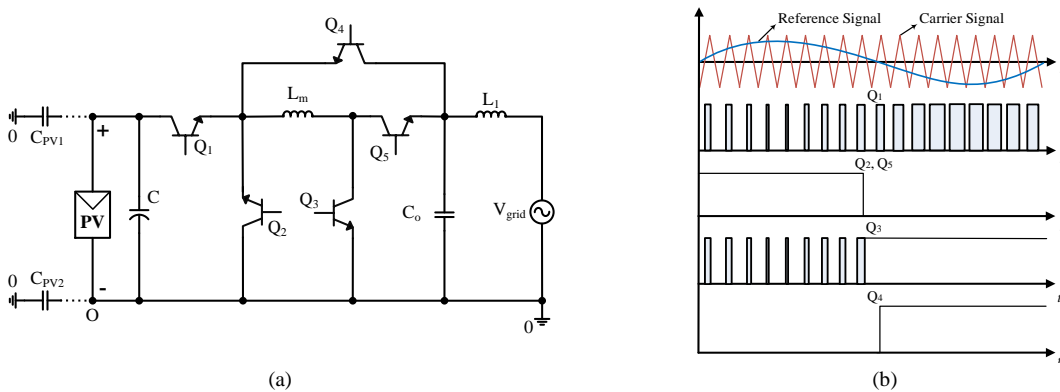

Fig. 20. Illustration of (a) inverter topology in [44], (b) its switching pulses.

$L_m$  is charged by the simultaneous conducting of switches  $Q_1$  and  $Q_3$ . However, the other three switches are used for discharging the flying inductor. The circuit structure of this topology is illustrated in Fig. 20 (a), and the gate pulses during operation are seen in Fig. 20 (b).

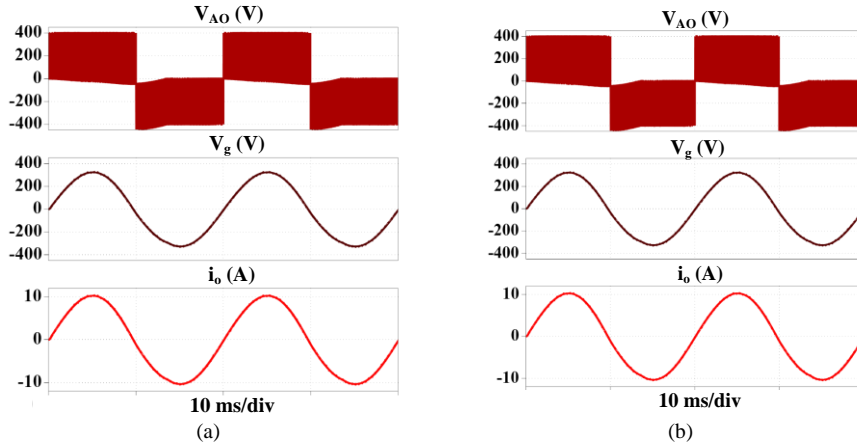

Fig. 21. Simulation results of common ground topologies, (a) inverter topology in [12], and (b) inverter topology in [5].

Fig. 21 displays the results of common ground topologies proposed in [5] and [12], where the flying capacitance ( $C_F$ ) is chosen as  $470 \mu\text{F}$ . Both figures (see Fig. 21 (a) and Fig. 21 (b)) show the inverter output, point A to ground (O) as well as the PV negative directly connected to ground through neutral and the output voltage ( $V_g$ ) and current ( $i_o$ ).

## 2) *H-Bridge Type Topologies*

### i. *Mid-point Clamped Type Topologies*

The FB inverter can be extended through the semiconductor devices at either AC or DC side for clamping the voltage. Such kind of topologies are known as the midpoint clamping transformerless inverter topologies. The main advantages of midpoint clamping techniques are the reduced  $i_{cm}$  with lower ripple than other topologies where the CMV remains constant. The mid-point clamping topologies, such as iH5/oH5 [92], and [93], oH5-1 [37], oH5-2 [94], and [95], H5-D [38], HERIC Active 1 [39], HERIC Active 2 [39], and [96], HERIC Active 3 [39], PN-NPC [40], and [97], HB-ZVR [7], and HB-ZVR-D [41], are explained focusing on the operational and working principle. Further, simulated waveforms are presented.

#### a) *iH5/oH5*

This topology is presented in [9], and [37] where two switches ( $Q_5$  and  $Q_6$ ) are added at the DC side as revealed in Fig. 22 (a). The switching pulses are presented in Fig. 22 (b).

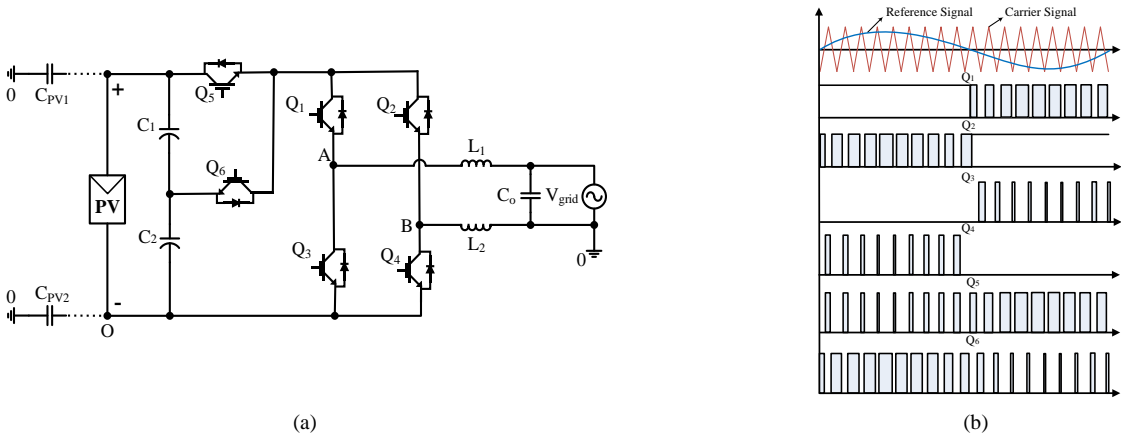

Fig. 22. Illustration of (a) oH5 inverter, and (b) its switching pulses.



The voltage clamping part of this topology is achieved in two ways. At potential up, the body diode of switch  $Q_6$  is in the forwarding mode with the junction capacitor of switch  $Q_5$  and DC link capacitor  $C_1$  where the current flow path is  $Q_1$  and the body diode of  $Q_2$  through the grid.

On the other hand, at potential down, switch  $Q_6$  is in active mode with the junction capacitors of switch  $Q_3$ ,  $Q_4$  and DC link capacitor  $C_2$  where the current flow path is switched to  $Q_3$  and the body diode of  $Q_4$  through the grid. The main advantage of this topology is the achieved good differential mode characteristic, which is the same as unipolar SPWM FB grid-connected inverter, but with higher efficiency. Moreover, extra switches on DC side blocks the input voltage to be half; hence a constant CMV can be achieved.

**b) oH5-1 and oH5-2**

The oH5 topology (both 1 and 2) as shown in Fig. 23 is introduced in [44] to guarantee the clamping to half input voltage in the freewheeling period, thereby avoiding the high-frequency common-mode voltage. The two switches ( $Q_5$  and  $Q_6$ ) and diodes ( $D_1$  and  $D_2$ ) are used to clamp the voltage for constant CMV, which reduces the ground current. Switches  $Q_1$  to  $Q_4$  work like an FB inverter. Switches  $Q_5$  and  $Q_6$  are alternative to each other. Switches  $Q_1$  and  $Q_2$  work with the grid frequency ( $f_g$ ), and the other four work at the switching frequency ( $f_{sw}$ ).

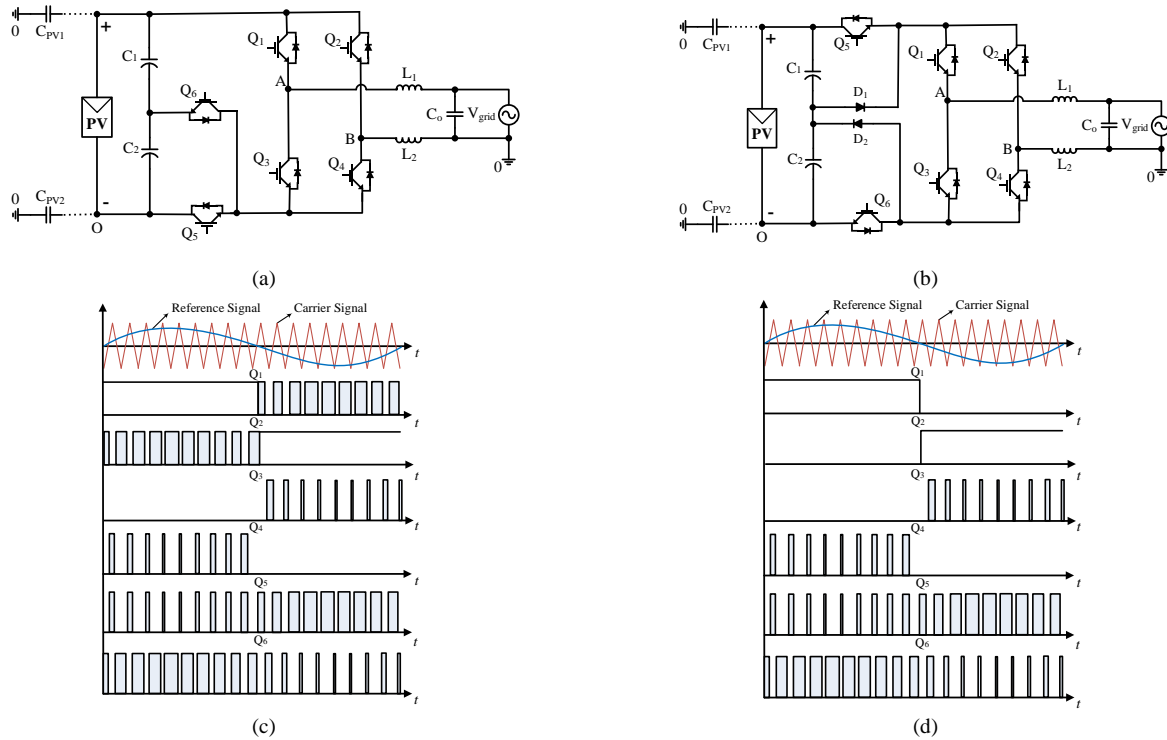

Fig. 23. Illustration of (a) oH5-1 inverter, (b) oH5-2 inverter, (c) switching pulses for oH5-1 inverter, and (d) switching pulses for oH5-2 inverter.

**c) H5-D**

The topology named as H5-D is presented in [38] where five switches are used together with a diode. This topology is an improved H5 topology, in which diode ( $D_1$ ) and switch ( $Q_5$ ) are used to clamp the input voltage in order to achieve a constant CMV. On the other hand, the improved modulation technique is set to keep the CM voltage constant. The CM current is only about one-third of that in H5 topology using the same electrical parameters and power switches. On the other hand, The THD

is quite high as H5 topology. The circuit diagram and the modulation strategy as shown in Fig. 24 reveal that the two switches operate at the grid frequency ( $f_g$ ), and the remaining three switches operate at the switching frequency ( $f_{sw}$ ).

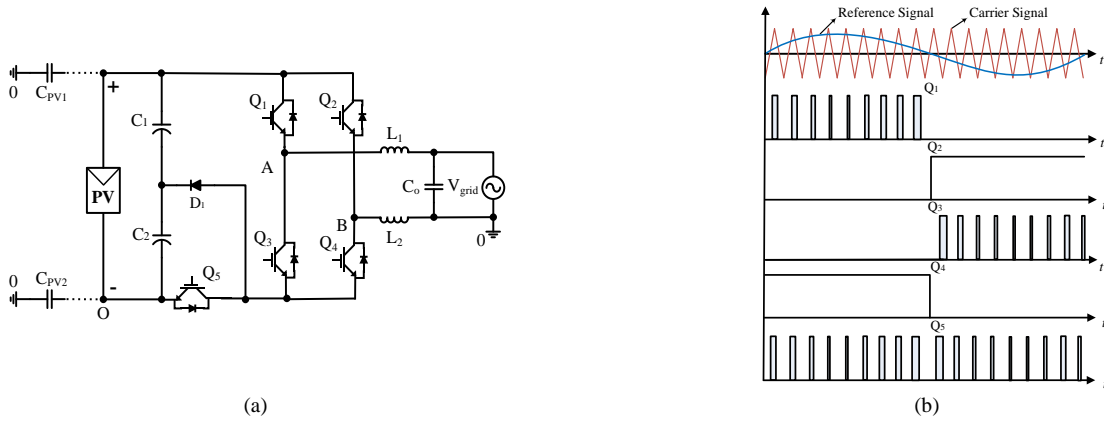

Fig. 24. Illustration of (a) H5-D inverter, and (b) its switching pulses.

**d) HERIC Active 1, HERIC Active 2 and HERIC Active 3**

As discussed in the AC decoupling subsection, in the HERIC topology, it is shown that the leakage current is in the medium range and the CMV is not fully constant. Three major topologies are proposed by changing and adding the placement of semiconductor devices; see Fig. 25 (a) to Fig. 25 (c). Fig. 25 (d) shows the switching pulses to keep  $i_{cm}$  constant with low  $i_{cm}$  [37], [94]. The main disadvantage of these topologies is the shoot-through issue in the unidirectional controllable clamping path. Hence, a dead time should be introduced to avoid the short circuit issue [98].

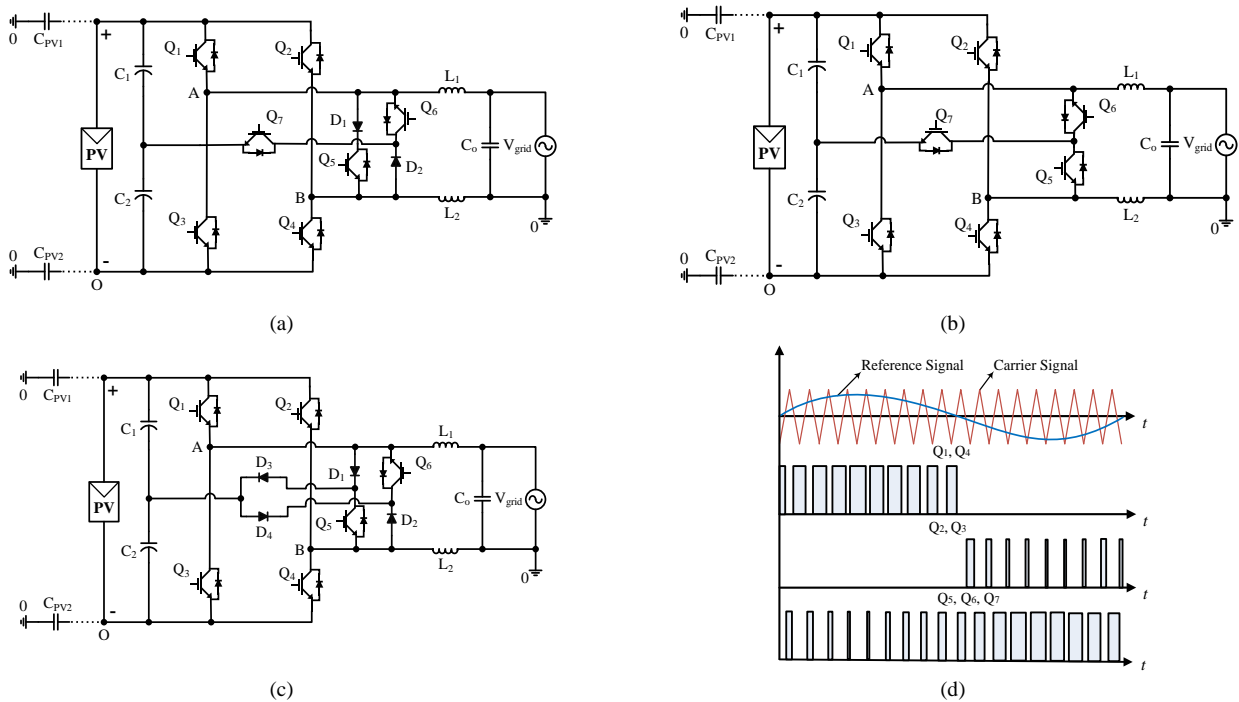

Fig. 25. Modifications of HERIC inverter, (a) HERIC Active-1 inverter, (b) HERIC Active-2 inverter, (c) HERIC Active-3 inverter, and (d) their switching pulses.

**e) PN-NPC**

Positive negative NPC (PN-NPC) is proposed in [40] which combines the positive NPC (P-NPC) and negative NPC (N-NPC) switching cells. The circuit diagram of PN-NPC is illustrated in Fig. 26 (a) with the switching modulation in Fig. 26 (b). In this topology, four switches work at the grid frequency ( $f_g$ ) while the other four work with the switching frequency ( $f_{sw}$ ).

This topology can operate in four operational modes for each period of the utility grid. In the freewheeling period, four switches are ON so that the inductor current flows through all of those switches, which can cause high conduction losses.

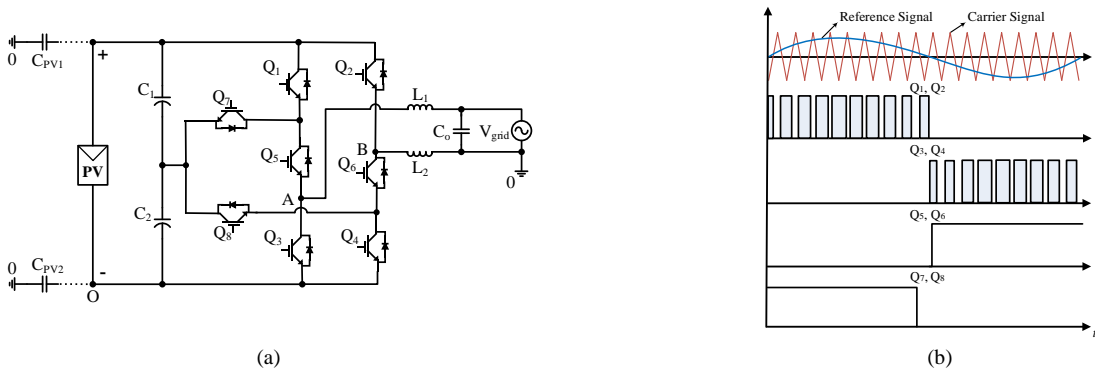

Fig. 26. Illustration of (a) PN-NPC inverter, and (b) its switching pulses.

**f) HB-ZVR, and HB-ZVR-D**

H-Bridge Zero Voltage Rectifier (HB-ZVR) (see Fig. 27 (a)) topology is presented in [9] where four switches work like the FB inverter and the short-circuit voltage clamped to the midpoint of DC bus is done by four rectified diodes and bidirectional switch.

In the positive half cycle,  $Q_1$  and  $Q_4$  work to generate the active vector as shown in Fig. 27 (c). Similarly, in the negative half cycle,  $Q_2$  and  $Q_3$  are ON and work to generate the active vector. When  $Q_5$  is ON, and the other switches are OFF. Thus, zero voltage states can be achieved.

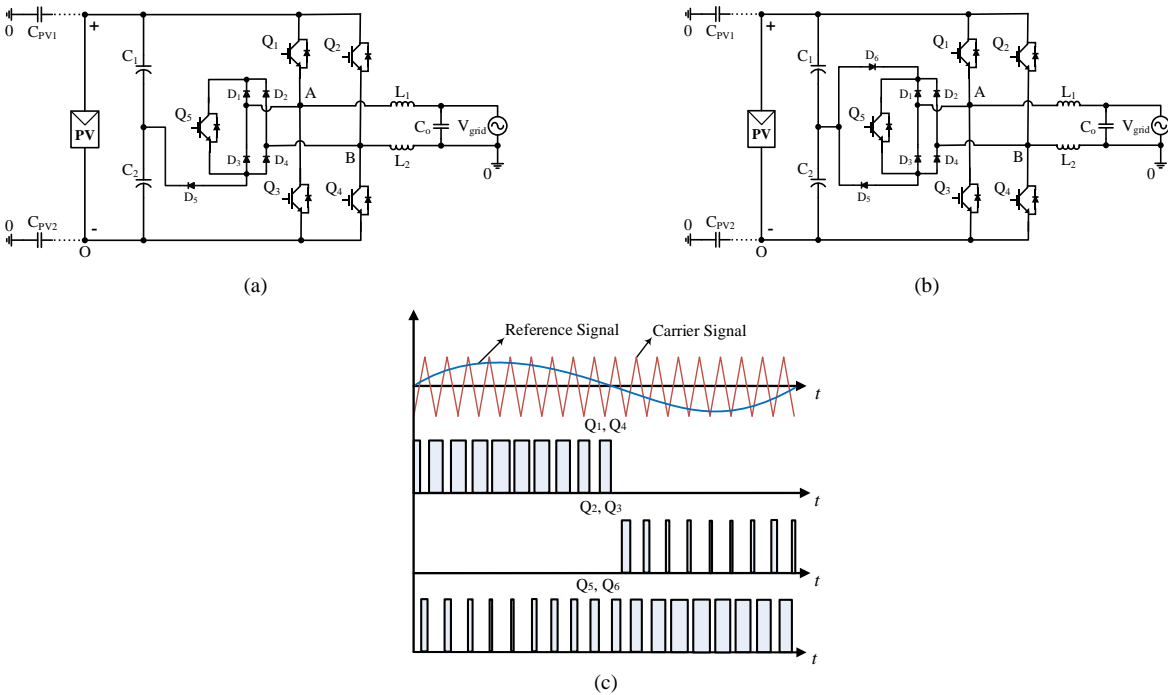

Fig. 27. HB-ZVR family inverters, (a) HB-ZVR inverter, (b) HB-ZVR-D inverter, and (c) their switching pulses.

The circuit structure of the H-Bridge Zero Voltage Rectifier-Diode (HB-ZVR-D) is revealed in Fig. 27 (b) with gate drive signals in Fig.27 (c) [41], which is very similar to HB-ZVR. The difference between these two topologies is a fast-recovery diode, which is used to achieve zero  $i_{cm}$  and constant CMV. The two diodes ( $D_5$  and  $D_6$ ) are used for clamping branches of the freewheeling path.

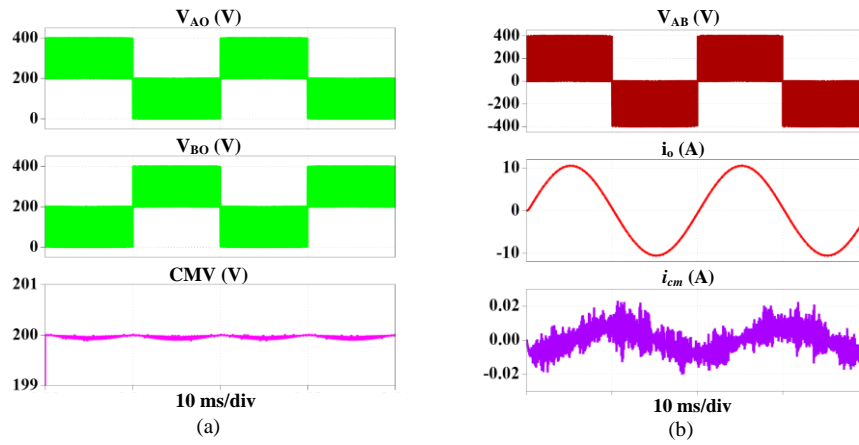

Fig. 28. Simulation results of iH5/oH5 inverter.

Fig. 28 (a) shows the voltage of the terminal A to neutral and terminal B to neutral where it is able to achieve a constant CMV. As it can be seen a low value of  $i_{cm}$  can be seen in Fig.28 (b) with low ripple on the output current. Fig. 29 shows the result for oH5-1 topology. It can be seen that the output current shows less ripple, the CMV is not sufficiently constant, and the common mode current is in the medium range.

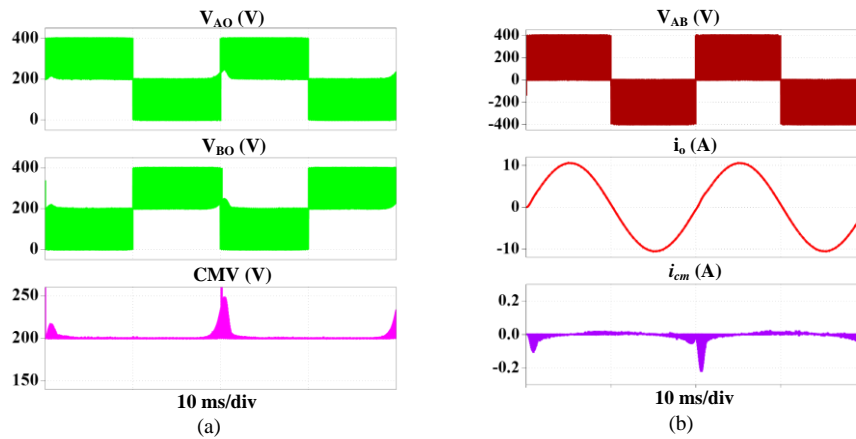

Fig. 29. Simulation results of oH5-1 inverter.

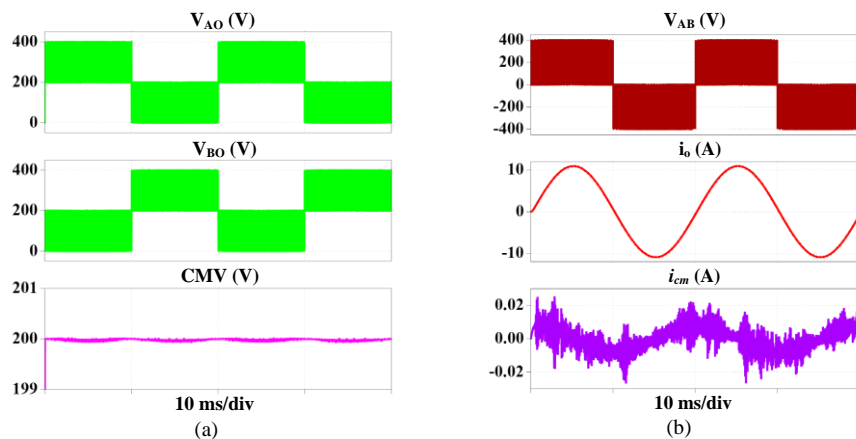

Fig. 30. Simulation results of HERIC Active-1 inverter.

With the additional placement of switches and diodes on the HERIC topology, as shown in Fig. 30,  $i_{cm}$  can be reduced more to have a constant CMV. The PN-NPC result is shown in Fig. 31 (a) and Fig. 31 (b) where a low  $i_{cm}$  with constant CMV is achieved.

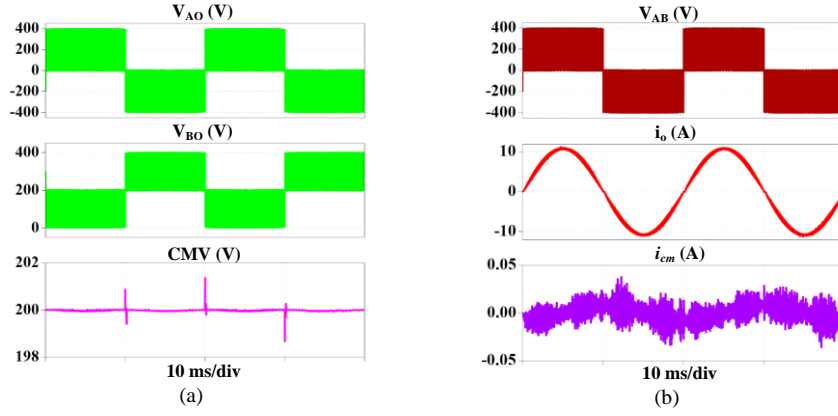

Fig. 31. Simulation results of PN-NPC inverter.

The resulting wave forms for HB-ZVR are shown in Fig. 32 (a), which achieves an almost constant CMV and medium range of  $i_{cm}$ . However, the HB-ZVR-D achieves low  $i_{cm}$  with an almost constant CMV as shown in Fig. 32 (b).

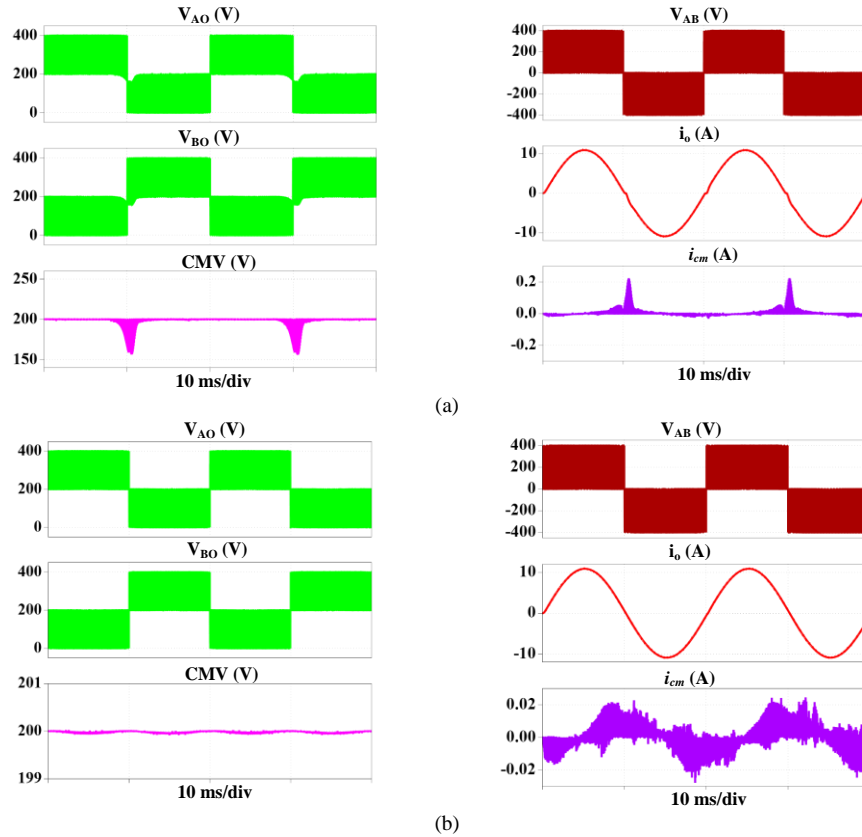

Fig. 32. Simulation results of HB-ZVR family inverters, (a) HB-ZVR inverter, (b) HB-ZVR-D inverter.

## ii. Decoupling techniques

### AC Decoupling

AC decoupling based transformerless inverter topologies are extended by adding switches and diodes at the AC side. These kinds of topologies are presented to achieve low THD based output voltage and current. Moreover, the leakage current is reduced with a balanced system and constant CMV. The AC decoupling topologies are HERIC and HERIC AC based topologies [9], [31], and [99].

The HERIC topology is well known in string inverters for achieving high efficiency, which is first invented in 2003 [80]. In addition, in the German manufactured Sunways NT solar inverter, it is highly recommended to use this topology. Moreover, 5 kW string inverters are investigated, which achieve 98% efficiency [100]. This topology employs Unipolar-SPWM to achieve

low current ripple and high efficiency because the load current is short-circuited through the switches  $Q_5$  and  $Q_6$  during the freewheeling period. On the other hand, the CM issue is present there as the PV module is decoupled from the grid and voltage is not clamped to the half of the supply voltage [101]. The HERIC AC based topology is similar to the HERIC topology, which uses two diodes with the switches  $Q_5$  and  $Q_6$  in series as proposed in [99], and [102]. These two diodes are used to conduct the output current at the freewheeling time. The operational mode of these topologies is the same as the FB inverter; the only difference is the output current flow path through the additionally used diodes and switches in the freewheeling period. The circuit diagrams of both topologies are given in Fig. 33 (a) and Fig. 33 (b) respectively and the gate drive signals in Fig. 33 (c).

The simulation results for HERIC topology are illustrated in Fig. 34. The obtained CMV is almost constant, and the  $i_{cm}$  is 160 mA. The main advantage of this topology is the obtained less ripple on the output. Hence the THD is very low.

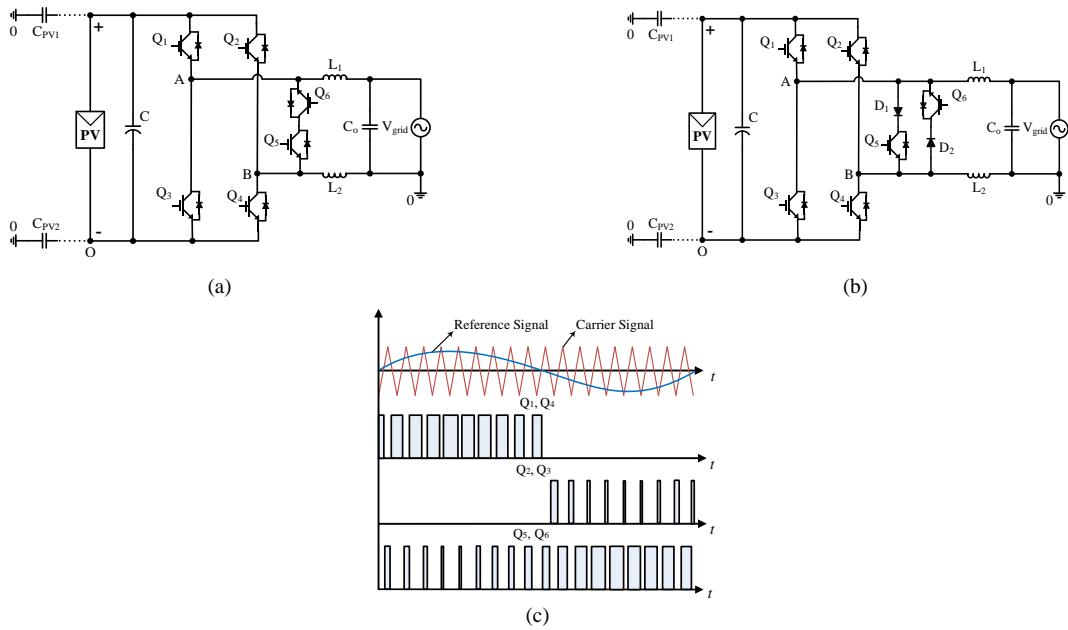

Fig. 33. (a) HERIC (b) HERIC ac based (c) Switching pulses.

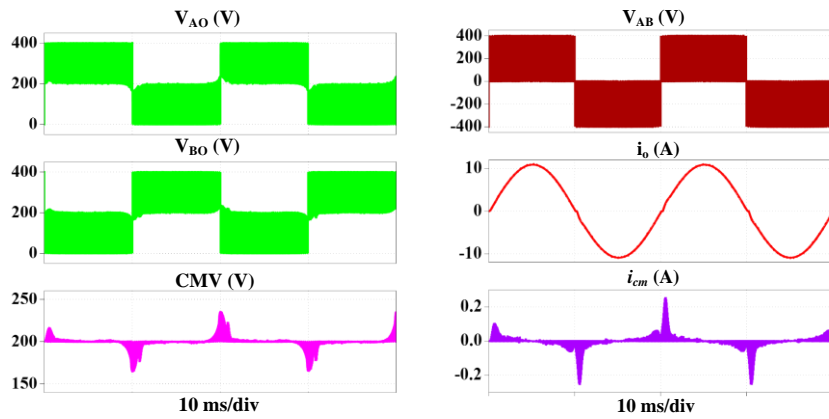

Fig. 34. Simulation results of HERIC inverter.

### DC Decoupling Type Topologies

The extra switches and diodes on the DC side are added for inventing new topologies and such kind of topologies are known as DC decoupling based transformerless inverter topologies. These topologies are introduced for mitigating the common

mode current for balancing the system. A few topologies are explained below such as H5 [92], H6 DC side [54], H6 DC side - 1 [33] and H6 DC side -2 [33] topologies.

**a) H5**

The H5 topology is a high efficiency based transformerless inverter topology and is first proposed in [32] which is patented by one of the best PV inverter producers, SMA solar technology. Its operational principle is almost same as the F-B. However, one switch is used on the DC side, which is called the DC decoupling switch. This switch is operated at the switching frequency ( $f_{sw}$ ). The upper switches are operated with grid frequency ( $f_g$ ), and the lower switches are operated with the switching frequency ( $f_{sw}$ ). The PV panel is disconnected from the grid side during zero voltage states when the switch  $Q_5$  is OFF; as a result, the current freewheeling period, there is no way to flow the output current at DC side which is an effective solution to reduce the  $i_{cm}$  [39], [103], and [104]. In the positive half cycle, switches  $Q_5$  and  $Q_4$  turn ON at the switching frequency ( $f_{sw}$ ), and  $Q_1$  at the grid frequency ( $f_g$ ) whereas the other two switches are OFF.

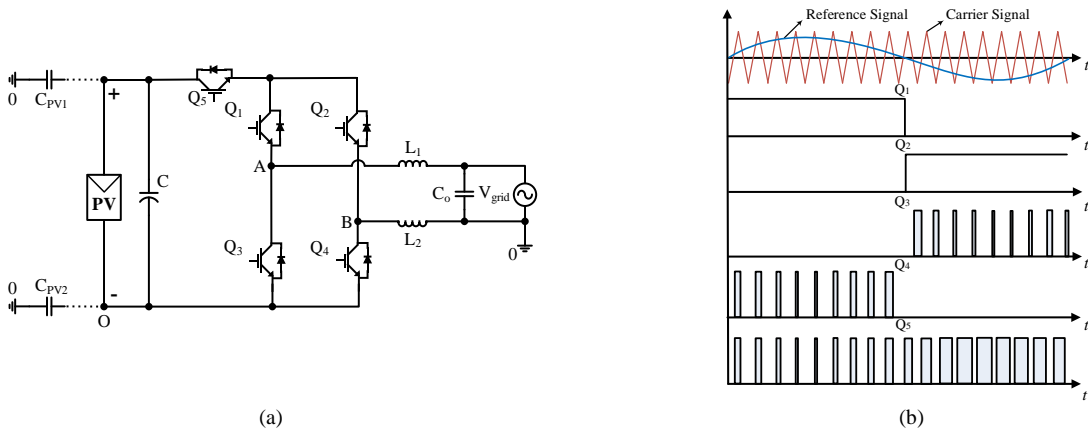
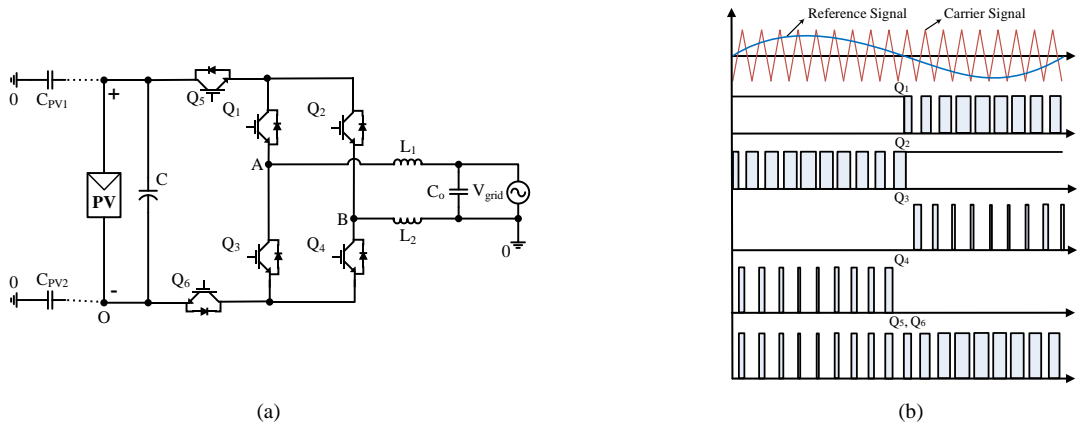

Fig. 35. Illustration of (a) H5 inverter, and (b) its switching pulses [8].

On the contrary,  $Q_5$  and  $Q_2$  turn ON at the switching frequency ( $f_{sw}$ ) and  $Q_3$  at grid frequency ( $f_g$ ) whereas the other two switches are OFF in the negative half cycle. At the freewheeling period, the output current flows through  $Q_1$  and the body diode of  $Q_3$  for the positive period, and through  $Q_3$  and the body diode of  $Q_1$  for the negative period. The main disadvantage of this topology is the higher conduction losses through the three associated series switches in the active phase [105]. The circuit structure and switching modulation of the H5 are shown in Fig. 35 (a) and Fig. 35 (b) respectively.

**b) H6 DC side**

The H6 DC side topology is displayed in Fig. 36 (a) with the gate drive signals in Fig. 36 (b). This topology is introduced in [48], which is operated in four stages. Moreover, the presence of junction capacitor in the H6 DC side topology as like as H5 topology is explained in [49] and [106], as well as the effect of the resonant circuit through the junction capacitor and thereby the leakage current issue. The switches  $Q_5$ ,  $Q_1$  and  $Q_6$  conduct in the positive half cycle, while  $Q_3$  and  $Q_2$  are OFF. On the freewheeling period of positive and negative half cycle, the body diode of  $Q_3$  is in the forward bias with conducting switch  $Q_1$ , and the body diode of  $Q_4$  is in the forward bias with conducting switch  $Q_2$  respectively. In this topology, extra low value capacitors are used to remove the CM effect which is the reason for increasing the losses [107].



(a) (b)  
Fig. 36. Illustration of (a) H6 DC side inverter, and (b) its switching pulses [29].

**c) H6 DC side -1 and H6 DC side -2**

These two topologies are presented in [33], and the concept is taken from the aforementioned topologies H5 [32] and H6 [48]. The positive terminal of the PV array and the terminal (A) are connected through a switch  $Q_6$  to make a current path as seen in Fig. 37 (a), and further the terminal (A) is changed to terminal (B), which is shown in Fig. 37 (b). In both topologies, the gate drive signals are the same (see Fig 37 (c)). These topologies work in four operational modes. The switches  $Q_1$  and  $Q_3$  work at the grid frequency ( $f_g$ ), and the other four switches work at the carrier frequency ( $f_{sw}$ ). In the freewheeling period, switch  $Q_1$  conducts with the body diode of  $Q_3$  for the positive half cycle; the switch  $Q_3$  and the body diode of  $Q_1$  are ON for the negative half cycle. Both topologies have less power losses compared to H5. Fig. 38 illustrates the output waveforms of H5 where the inverter output voltage and the output current are shown. The  $i_{cm}$  is around 200 mA with an almost constant CMV.

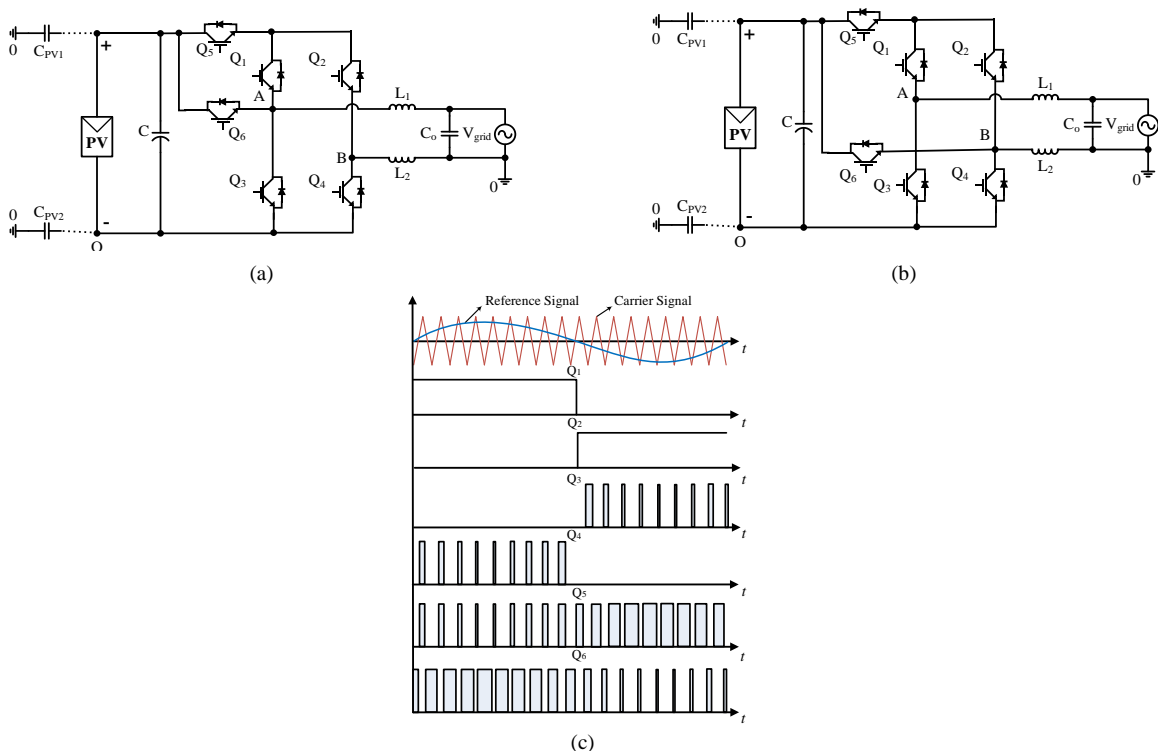

(a) (b) (c)  
Fig. 37. Illustration of (a) H6 DC side-1 inverter, (b) H6 DC side-2 inverter, and (c) their switching pulses.



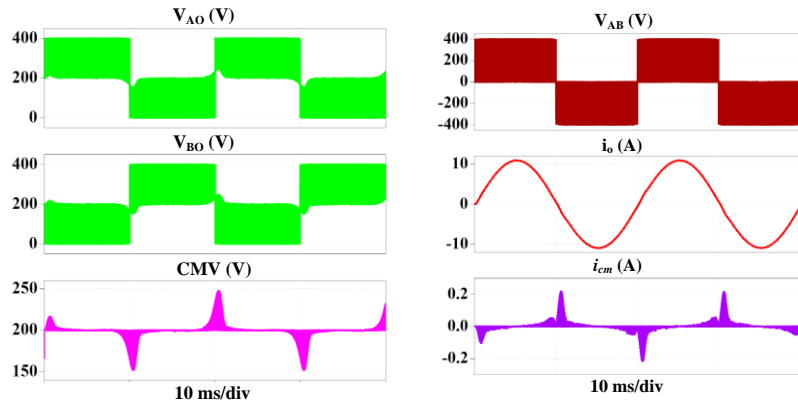

Fig. 38. Simulation results of H5 inverter.

### 3) H6 Type Topologies

F-B topologies are extended with switches and diodes to reduce the leakage current with smoother output waveforms. In this sub-section, those kinds of topologies are presented like H6 with diodes-1 [34], H6 with diodes-2 [63], H6-1 [35], H6 in mid-switch [36], and midpoint switches with diodes [39], and [49]. Further, the circuits are simulated to see the output waveforms,  $i_{cm}$  and CMV.

#### a) H6 with diodes-1 and H6 with diodes-2

H6 with diodes-1 is presented in [34], which is structured by Metal-Oxide-Semiconductor Field-Effect Transistor (MOSFET) switches. Four MOSFETs work as an F-B inverter as well as two extra switches and the diodes are used for freewheeling purposes. The same basic concept is used for H6 with diodes-2 topology. Fig. 39 (a) shows the circuit structure of H6 with diodes-1 and in Fig. 39 (c) is the circuit diagram of H6 with diodes -2. Meanwhile, Fig. 39 (b) and Fig. 39 (d) show the switching pulses for these two topologies. After simulating these two topologies,  $i_{cm}$  is obtained as around 200 mA for H6 with diodes-1 and 250 mA for H6 with diodes -2 topology. However, in both cases, the CMV is quite constant. To reduce the  $i_{cm}$  correctly, an accurate modulation technique is needed. Hence, in [108] a topology is proposed, which replaces the switches  $Q_5$  and  $Q_6$  by two IGBTs and uses a new modulation controller based on reactive power injection space vector PWM (SVPWM) technique as well as using proportion-integral-resonance (PIR) current controllers. The main demerit of these topologies is the higher conduction losses in the active mode as the output current is flowing through the three switches [107].

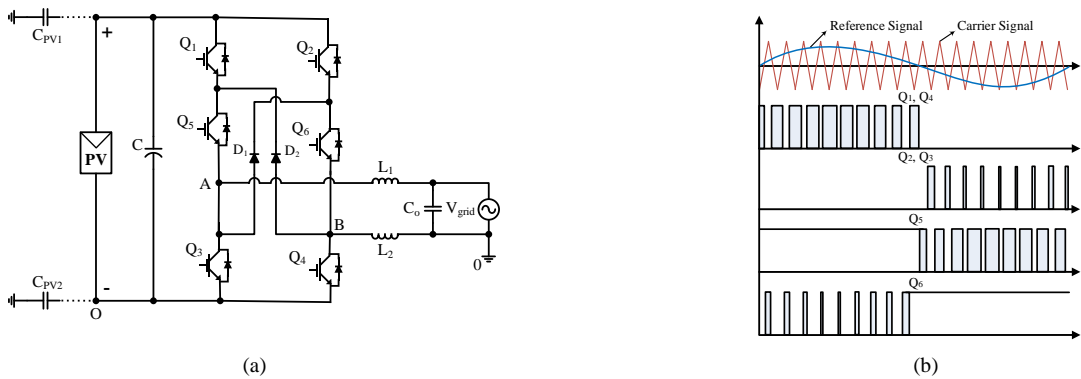

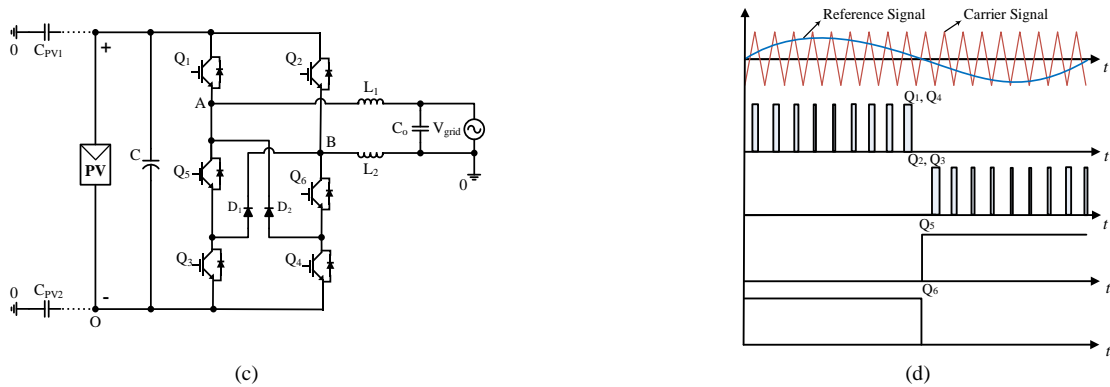

Fig. 39. Illustration of (a) H6 with diodes-1 inverter, (b) its switching pulses, (c) H6 with diodes-2 inverter, and (d) its switching pulses. [57].

**b) H6-1 topology**

H6-1 topology is proposed in [35], and the idea is taken from the topologies including six switches with two diodes as discussed in [34], and [36]. However, the extra cross connected diodes are removed and MOSFET switches are replaced with IGBTs, as demonstrated in Fig. 40 (a) with the switching pulses in Fig. 40 (b). Hence, it is possible to handle the reactive power flow, which is not possible by MOSFET based topologies [109]. It works in six operational modes and makes a connection internally whereas creating a freewheeling path. Therefore, the circuit operates smoothly when it is connected to the grid. In the positive half cycle,  $Q_1, Q_6$  and  $Q_4$  are ON, and the current flows through the inductors, completing the cycle. Moreover, zero voltage state switch  $Q_6$  and the antiparallel connected body diode of switch  $Q_5$  are conducting, which are not connected with the input; and the current flows through the load. On the other hand, the remaining three switches  $Q_2, Q_5$  and  $Q_3$  conduct in the negative half cycle. A zero voltage state occurs in the negative half cycle, and the current flows between the switch  $Q_5$  and the antiparallel connected body diode of switch  $Q_6$ .

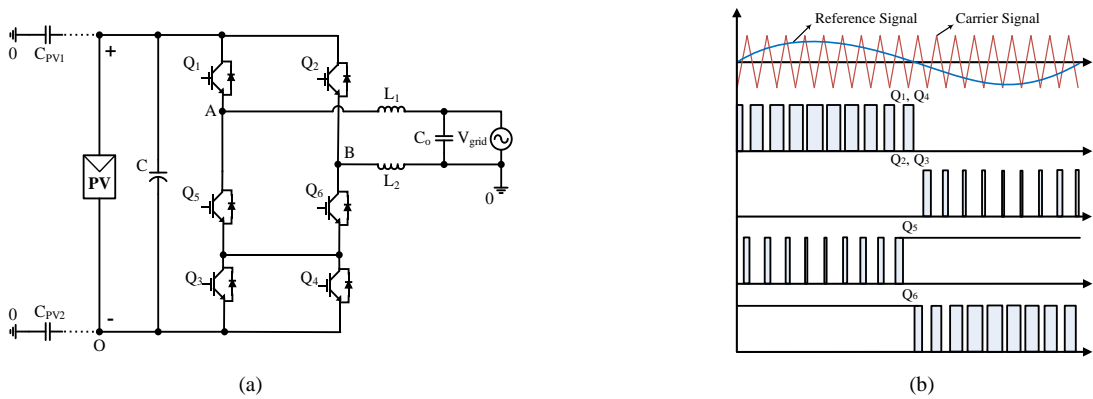

Fig. 40. Illustration of (a) H6-1 inverter, and (b) its switching pulses [58].

The topology H6-1 [35] can be modified after changing the position of point A to B and B to A, and this topology also works in six operating modes like H6-1 [35]. The modified one can be simulated after changing the switching pulse  $Q_5$  of the H6-1 to  $Q_6$ , and the other pulses remain the same. Indeed, the THD is reduced a little bit.

**c) H6 in mid Switch**

H6 in mid-switch topology is presented in [36] which has four operational modes. Fig. 41 (a) displays the schematic diagram of the midpoint switch based H6 topology, and the switching pulse is shown in Fig.41 (b). Moreover, the mid switch  $Q_6$  is used to complete the circuit for the freewheeling period. In the positive half cycle, the freewheeling path works through

the switch  $Q_6$  and the body diode of  $Q_5$ . On the other hand, for negative half cycle, the body diode of  $Q_6$  is in active mode with the  $Q_5$  switch. The main disadvantages of this topology are the high volume of the filter capacitor, and high ripple based output waveforms.

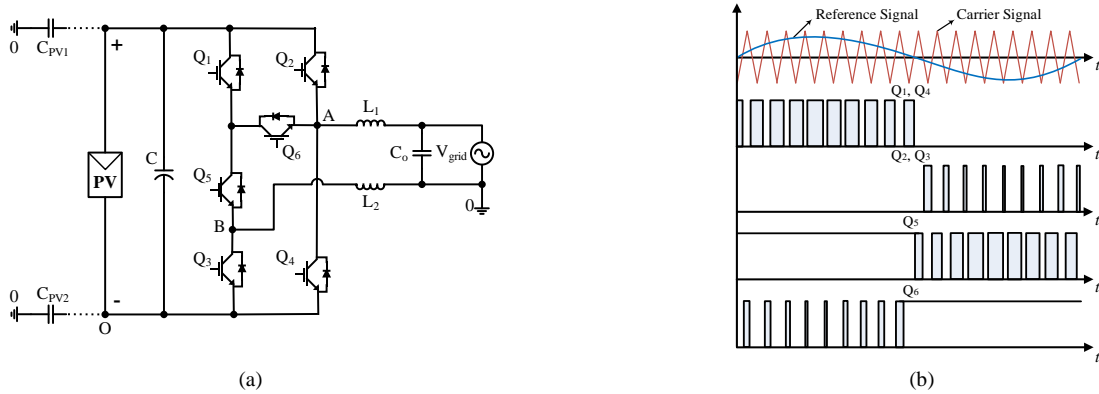

Fig. 41. Illustration of (a) H6 with mid switch inverter, and (b) its switching pulses [60].

**d) F-B with midpoint-switches and diodes**

In [39], [49] and [110], a topology is discussed where the idea is taken from H5 topology. Two extra switches are added at the top and bottom of the middle of F-B topology, and the two diodes are used for creating a freewheeling path. This topology is also known as hybrid bridge topology [111]. Moreover, the topology consists of two modules such as H-B and NPC bridge. The circuit diagram is displayed in Fig. 42 (a). Switches  $Q_1$  and  $Q_6$  are conducting together when  $Q_4$  is conducting. On the other hand,  $Q_5$  works with the same switching pulses as  $Q_2$  while  $Q_3$  is continuously ON.

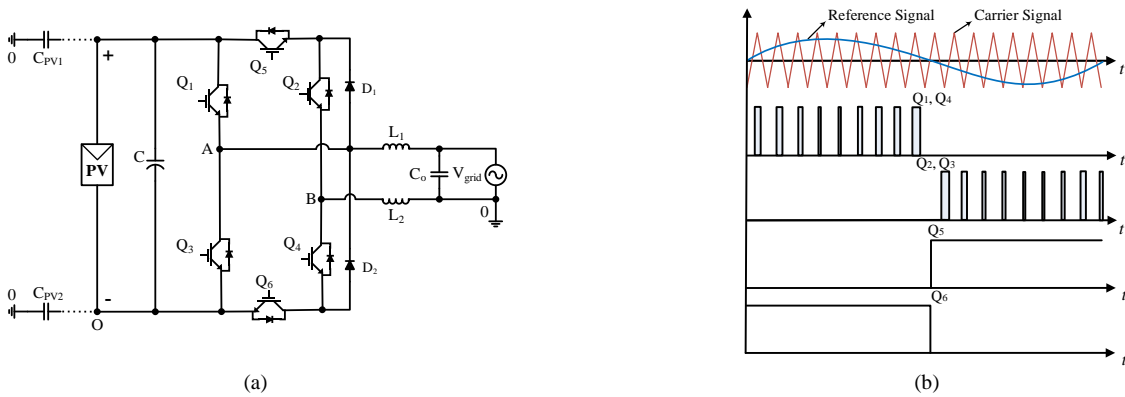

Fig. 42. Illustration of (a) F-B inverter with midpoint-switches and diodes, and (b) its switching pulses [107].

The switching strategy is shown in Fig. 42 (b). In the freewheeling period, during the positive half cycle,  $D_2$  works in forwarding bias with the conducting switch  $Q_4$ , and the output current flows through the load. Alternatively, during the negative half cycle,  $D_1$  is in forward bias with  $Q_2$ . In this topology, the most important is that the dead time is fixed because switches  $Q_1, Q_2, Q_4, Q_6$ , and diode  $D_1$  might be turned ON once in the positive half cycle.

**e) ZCT-H6-1 and SCF-H6-1**

Using zero-current-transition (ZCT) technique, a new transformerless inverter is discussed in [65] as shown in Fig. 43 (a). In this topology, two auxiliary switches ( $Q_7$ , and  $Q_8$ ) and two H6 switches ( $Q_5$ , and  $Q_6$ ) are operated at high frequency, whereas the full-bridge inverter switches  $Q_1 - Q_4$  operate at the line-frequency. In addition, few resonant components are also

used in this topology to realize ZCT operation. As a result of using many additional components, the overall efficiency is comparatively low.

Another improved soft-switching circuit called switching loss-free (SLF) inverter is introduced in [66], where it is possible to reduce the number of auxiliary components (see Fig. 43 (b)). Compared to the s ZCT-H6-1 topology, the connection points of two resonant tanks are moved from the midpoints of the auxiliary switch and resonant capacitor to the midpoints of the resonant capacitor and resonant inductor, respectively. With this arrangement, this new topology is able to obtain over 95% efficiency over a wide load range, which is roughly 1.5% higher than the ZCT-H6-1 topology. Moreover, SCF-H6-1 topology mitigates more leakage current than ZCT-H6-1 topology. Fig. 43 (c) shows the required gate signals for both topologies.

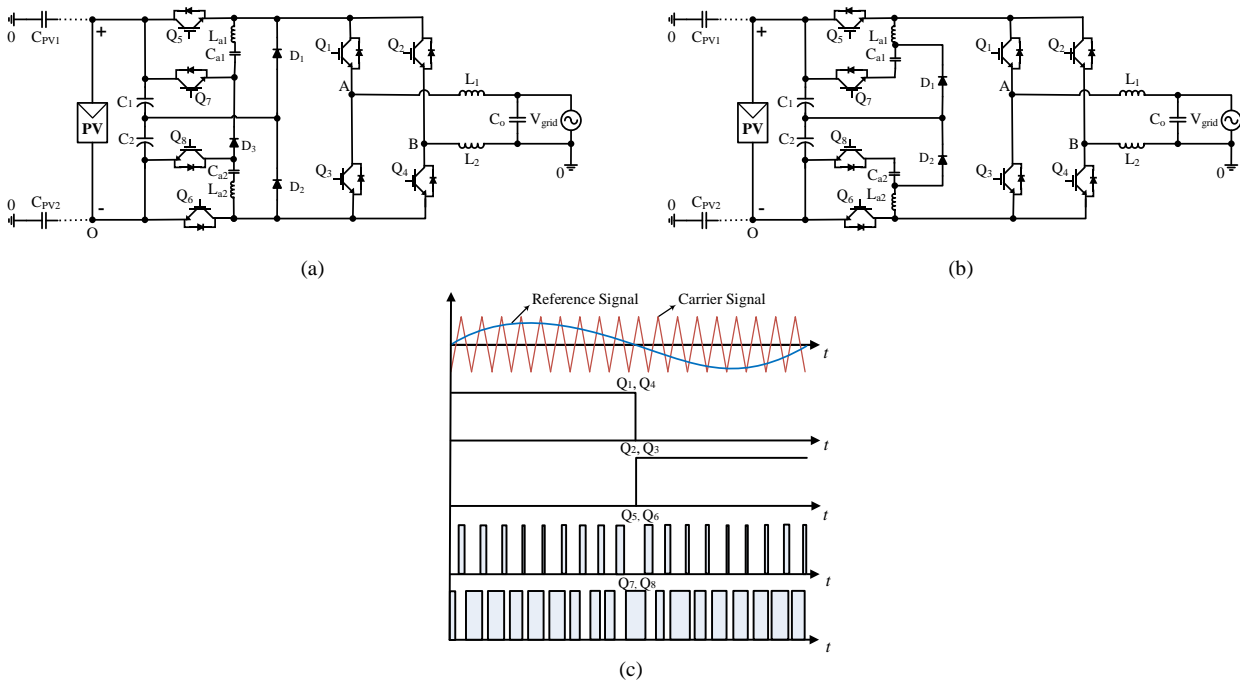
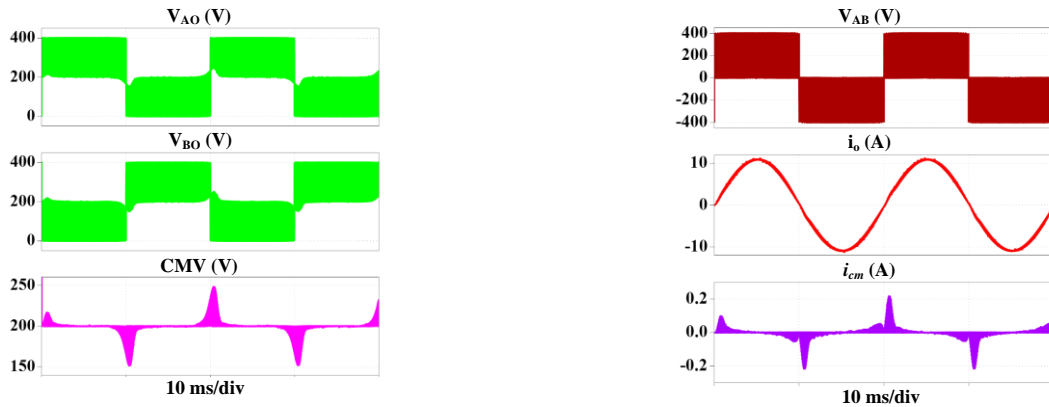

Fig. 43. Illustration of (a) ZCT-H6-1 [65], (b) SCF-H6-1 [66], and (b) its switching pulses.

Fig. 44 (a) displays the output voltage and current of the H6-1 topology with the  $i_{cm}$ . The RMS value of  $i_{cm}$  is around 180 mA, and the CMV remains almost constant. Fig. 43 (b) shows the output voltage and the current of hybrid bridge topology.



(a)

The CMV is almost constant like H6-1 topology. The extra switches based on the F-B transformerless inverter topologies are used with the almost same techniques, that is, just changing the location of the diodes and bidirectional switches. Hence, the obtained CMV and  $i_{cm}$  are practically identical.

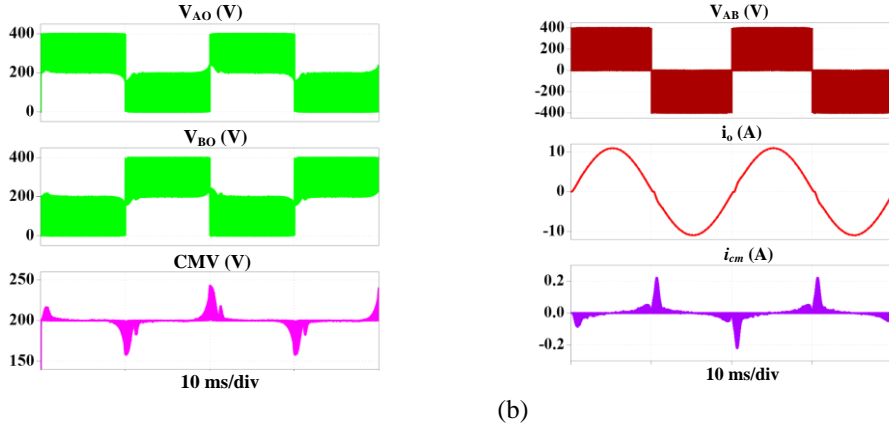

Fig. 44. Simulation results (a) H6-1, (b) F-B inverter with midpoint-switches and diodes.

#### 4) Buck-Boost Type Topologies

Buck-boost topologies are created by employing buck/boost and buck-boost topologies in the circuit to avoid complexity of single-phase transformerless inverters. As a result, the  $i_{cm}$  can be reduced dramatically for some buck-boost topologies [69-70]. In some topologies like [112], there is a direct connection between the ground of PV panel and load, and hence no leakage current will flow through the parasitic capacitor. However, their THD values might be high.

In [70], a boost converter is used at the front of the circuit that helps in reducing the minimum required input voltage level. In this topology, extra switches are used to clamp the mid-point voltage, and hence the CMV is remained constant with low level of  $i_{cm}$ . On the other hand, when the output voltage falls below the peak grid voltage, the DC-DC converter is energized in a way to charge the second DC-link capacitor such that the total DC-link voltage becomes more than the peak grid voltage. Thus, the topology is also used to increase the voltage level into five-level through the DC-link capacitors. Further, a high gain DC-DC converter based topology that is connected with doubly grounded voltage swing inverter is introduced in [72], which is able to reduce the components voltage requirement. However, such kind of topology utilize multiple stages and operates in high switching frequency, which results in a low conversion efficiency. Moreover, double PV panel is used with NPC and generation control circuit (GCC) to increase the DC-link voltage in [69]. This circuit construction allows the operation of each PV string at a different current-voltage point, which helps to avoid the partial shadowing problem. As a result, the maximum current of the most shaded PV module limits the current of the string. On the other hand, the output ground is directly connected to the mid-point of the DC-link capacitors, which is the main reason of getting low  $i_{cm}$ . The topology is implemented for 5 kW where the achieved efficiency is 96%. Moreover, the same technique is used in [68] and [7] obtaining a low  $i_{cm}$ . [72]

Table V summarizes the major single input type transformerless inverter topologies in terms of CMV, leakage current, voltage stress and number of components required which have been analysed previously.

TABLE V  
SUMMARY OF SINGLE INPUT VOLTAGE TYPE TRANSFORMERLESS INVERTERS.

Topology Name	Semiconductor Devices		No. of C*	No. of L	Common Mode Current $i_{cm}$ (mA)	Common Mode Voltage CMV (V)	Passive Filter		Output Voltage Level	Reported PF	Reported THD, (%)	Cost <sup>#</sup>	Reported Efficiency, $\eta$ (%)
	No. of IGBTs	No. of Diodes					No. of C	No. of L					
Bipolar F-B [62]	4	0	1	0	$\leq 55$	199 to 201	1	2	2	Unity	N/A	+	95.2 @ 5 kVA
Unipolar F-B [61, 103]	4	0	1	0	$\leq 1800$	200 to 400	1	2	3	Unity	N/A	+	98.0@3 kVA
Inverter topology in [12]	5	0	2	0	$\approx 0$	constant	1	1	3	0.94	2.1	++	95.20 @ 0.5 kVA
S4 Topology [42]	4	2	3	0	$\approx 0$	constant	1	1	3	0.8	2.1	++	97.2 @ 0.5 kVA
Siwakoti-H [16]	4	1	2	0	$\approx 0$	constant	1	1	3	0.85	< 2.3	++	97.8 @ 1 kVA
Inverter topology in [5]	4	1	2	0	$\approx 0$	constant	1	1	3	0.85	< 2	++	99.25 @ 1 kVA
Inverter topology in [43]	4	1	2	0	$\approx 0$	constant	1	1	3	0.9	< 2.2	++	99.2 @ 1 kVA
Inverter topology in [44]	5	0	2	1	$\approx 0$	constant	1	1	3	Unity	N/A	++	95 @ 200 VA
Karschny [45]	5	2	2	1	$\approx 0$	constant	1	1	3	Unity	N/A	+++	N/A
iH5/oH5 [10]	6	0	2	0	$\leq 20$	199.89 to 200	1	2	3	Unity	N/A	++	96.9 @ 1 kVA
oH5-1 [37]	6	2	2	0	$\leq 200$	200 to 248	1	2	3	Unity	N/A	+++	N/A
oH5-2 [37]	6	0	2	0	$\leq 200$	198to 249	1	2	3	Unity	N/A	++	97.16 @ 5 kVA
H5-D [38]	5	1	2	0	$\leq 50$	185to 195	1	2	3	Unity	4.888	++	95@650 VA
HERIC Active 1 [39]	7	2	2	0	$\leq 25$	199.93 to 200	1	2	3	N/A	N/A	++++	N/A
HERIC Active 2 [39]	7	0	2	0	$\leq 25$	199.96 to 200	1	2	3	N/A	1.7	++++	97 @ 2 kVA
HERIC Active 3 [39]	6	4	2	0	$\leq 25$	199.91 to 200	1	2	3	Unity	N/A	++++	N/A
PN-NPC [40]	8	0	2	0	$\leq 35$	199.3 to 201.1	1	2	3	Unity	N/A	++++	97.2 @ 1 kVA
HB-ZVR [9]	5	5	2	0	$\leq 200$	163 to 200	1	2	3	Unity	N/A	+++	94.88 @ 2.8 kVA
HB-ZVR-D [41]	5	6	2	0	$\leq 40$	199.89 to 200	1	2	3	Unity	1.9	+++	95.03 @ 1 kVA
HERIC [31]	6	0	1	0	$\leq 200$	165 to 235	1	2	3	Unity	N/A	++	97.1 @ 2 kVA
HERIC AC based [31]	6	2	1	0	$\leq 200$	165 to 236	1	2	3	Unity	N/A	+++	N/A
H5 [32]	5	0	1	0	$\leq 200$	159 to 235	1	2	3	Unity	N/A	++	98.50 @ 0.5 kVA
CH5 [113]	5	5	1	2	$\leq 50$	N/A	1	2	3	Unity	2.69		N/A
H6 DC side [29]	6	0	2	0	$\leq 200$	151 to 249	1	2	3	Unity	1.585	++	95.9 @ 1kVA
H6 DC side improved-1 [33]	6	0	1	0	$\leq 1000$	200 to 400	1	2	3	Unity	N/A	++	N/A
H6 DC side improved-2 [33]	6	0	1	0	$\leq 1000$	200 to 400	1	2	3	Unity	N/A	++	N/A
H6 in mid diodes-1 [34]	6	2	1	0	$\leq 200$	159 to 240	1	2	3	0.9937	1.86	++	97.33 @ 1 kVA
H6 with diodes-2 [34]	6	2	1	0	$\leq 200$	150 to 249	1	2	3	Unity	N/A	+++	97.31 @ 1 kVA
Improved H6 in mid diodes-1 [64]	6	2	1	0	$\leq 20$	190 to 200	1	2	3	0.9	N/A	+++	96.5 @ 4 KVA
H6 -1 [35]	6	0	1	0	$\leq 200$	151 to 258	1	2	3	Unity	1.7	++	97.22 @ 1 kVA
H6 in mid switch [36]	6	0	1	0	$\leq 200$	159 to 240	1	2	3	Unity	N/A	++	N/A
Hybrid bridge [30]	6	2	1	0	$\leq 250$	158 to 241	1	2	3	Unity	N/A	+++	94.75 @ 1 kVA
ZCT-H6-1 [65]	8	3	4	2	$\leq 250$	N/A	1	2	3	Unity	N/A	++++	95.6 @ 1 kVA
SCF-H6-1 [66]	8	2	4	2	$\leq 150$	N/A	1	2	3	Unity	N/A	++++	96.25@ 1 kVA
Inverter topology in [67]	4	2	1	0	$\leq 150$	N/A	1	6	3	0.9	3.6	++++	98.2 @ 2 kVA
Inverter topology in [68]	6	0	2	0	$\leq 250$	N/A	1	3	3	Unity	< 4.5	+++	94.8 @ 1.5 kVA
GCC-NPC [69]	6	2	2	1	$\leq 20$	N/A	1	1	3	Unity	4.08	++++	95.7 @ 2 kVA
Inverter topology in [70]	8	1	2	1	$\leq 20$	N/A	1	2	3	Unity	4.2	++++	96.11@ 220 VA
Inverter topology in [7]	8	0	2	0	$\leq 20$	N/A	2	2	3	Unity	4.35	++++	96@ 1 kVA
Inverter topology in [71]	6	2	1	1	$\leq 150$	N/A	1	2	3	Unity	N/A	+++	97.5@ 2 kVA
Inverter topology in [114]	8	4	4	2	$\leq 100$	N/A	1	3	3	Unity	< 4.61	++++	97.02@ 1.5 kVA
Inverter topology in [72]	7	3	4	4	$\leq 100$	N/A	1	1	3	0.7	N/A	++++	94.09@ 300 VA
Inverter topology in [115]	4	0	2	1	$\leq 200$	N/A	1	1	3	0.7	2.1	+++	95.8@ 100 VA
Inverter topology in [50]	6	0	3	0	$\leq 20$	N/A	1	3	3	0.95	N/A	+++	N/A
Inverter topology in [116]	5	2	4	2	$\leq 40$	N/A	0	1	3	Unity	N/A	++++	N/A

\* including the input capacitor

# The more "+" represents the higher cost, +  $\equiv$  low, ++  $\equiv$  medium, +++  $\equiv$  high, and ++++  $\equiv$  extremely high.

In the above table, "C" represents capacitor, "L" represents inductor, "PF" power factor, "THD" total harmonic distortion

#### IV. THERMAL ANALYSIS AND LOSS CALCULATION FOR EFFICIENCY EVALUATION

Inverters are operated in a wide range of temperature and their operating temperature affects the overall system cost and efficiency. Therefore, the thermal analysis is an important aspect for the technical analysis of a power electronics system, which affects the required heat sink size, cooling system and thermal protection of the switches [117]-[125]. The temperature needs to be considered for each semiconductor devices from junction temperature ( $T_j$ ) to case temperature ( $T_c$ ). Fig. 45 shows the thermal impedance model which is related to the temperature.

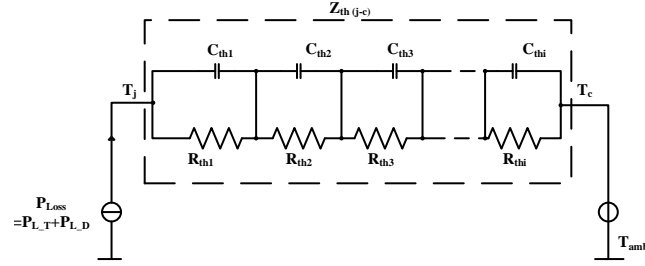

Fig. 45. Thermal impedance Foster- model used in circuit design.

The junction temperature depends on thermal capacities  $C_{th}$  and thermal resistances  $R_{th}$  through the following equations.

$$R_{th} = \frac{T_j}{\rho} = \frac{T_j}{Q/t} \quad (9)$$

where  $\rho$  is the heat flow,  $Q$  is the flowing heat, and  $t$  is the time,

$$\frac{1}{C_{th}} = \frac{T_j}{Q} \quad (10)$$

The total impedance is

$$Z_{thi}(t) = \frac{\Delta T}{P} = \sum_{i=1}^n R_{thi} (1 - e^{-\frac{t}{\tau_{thi}}}) \quad (11)$$

where  $\Delta T$  is the temperature between different nodes in the system,  $n$  is the number of exponential terms to fit  $Z_{th}(t)$  to the transient thermal impedance curve,  $P$  is the power dissipation, and

$$\tau_{thi} = R_{thi} \cdot C_{thi} \quad (12)$$

On the other hand, the power losses (IGBT ( $P_{L,T}$ ) + diode ( $P_{L,D}$ )) are dependent on the junction temperature and case temperature as shown in (13).

The junction temperature can be expressed as follows

$$T_j = P_{Loss} \cdot Z_{th(j-c)} + T_c \quad (13)$$

The junction temperature of the IGBT can be calculated by the following equation

$$T_{j-IGBT} = T_H + P_{avg,IGBT Loss} (R_{th-IGBT} + R_{th(ch-IGBT)}) \quad (14)$$

The junction temperature of the diode can be calculated by the following equation

$$T_{j-diode} = T_H + P_{avg,Diode Loss} (R_{th-diode} + R_{th(ch-diode)}) \quad (15)$$

The heatsink temperature can be found as given in (16).

$$T_H = T_{amb} + R_{th-H}(P_{avg,IGBT Loss} + P_{avg,Diode Loss}) \quad (16)$$

where  $T_{amb}$  represents the ambient temperature, and  $R_{th-H}$  stands for the thermal resistance between the heat sink and the environment.

Fig. 45 illustrates the junction temperature curves of the semiconductors in turn-ON and turn-OFF conditions. The maximum junction temperature is related to the bipolar F-B inverter [62], and hence the maximum losses occur through the switches, which are almost identical for all switches (see Fig 46 (a)). The junction temperature is dramatically reduced for all switches in the unipolar F-B inverter, where two switches ( $Q_1$  and  $Q_2$ ) are operated at a slightly lower temperature than the other two switches ( $Q_3$  and  $Q_4$ ); see Fig. 46 (b). Fig. 46 (c) and Fig 46 (d) illustrate the junction temperature curves for H5 and H6 DC side semiconductor devices. In these topologies, the additional switches ( $Q_5$  and  $Q_6$ ) represent an increase in the junction temperature in both turn-ON and turn-OFF conditions according to the switching pulses. The topology presented in [5] demonstrates the lowest junction temperature and loss among the evaluated topologies (see Fig. 46(e)). Moreover, the junction temperature curves for semiconductor switches in HERIC and HB-ZVR topologies are illustrated in Fig 46 (f) and Fig. 46 (g), respectively.

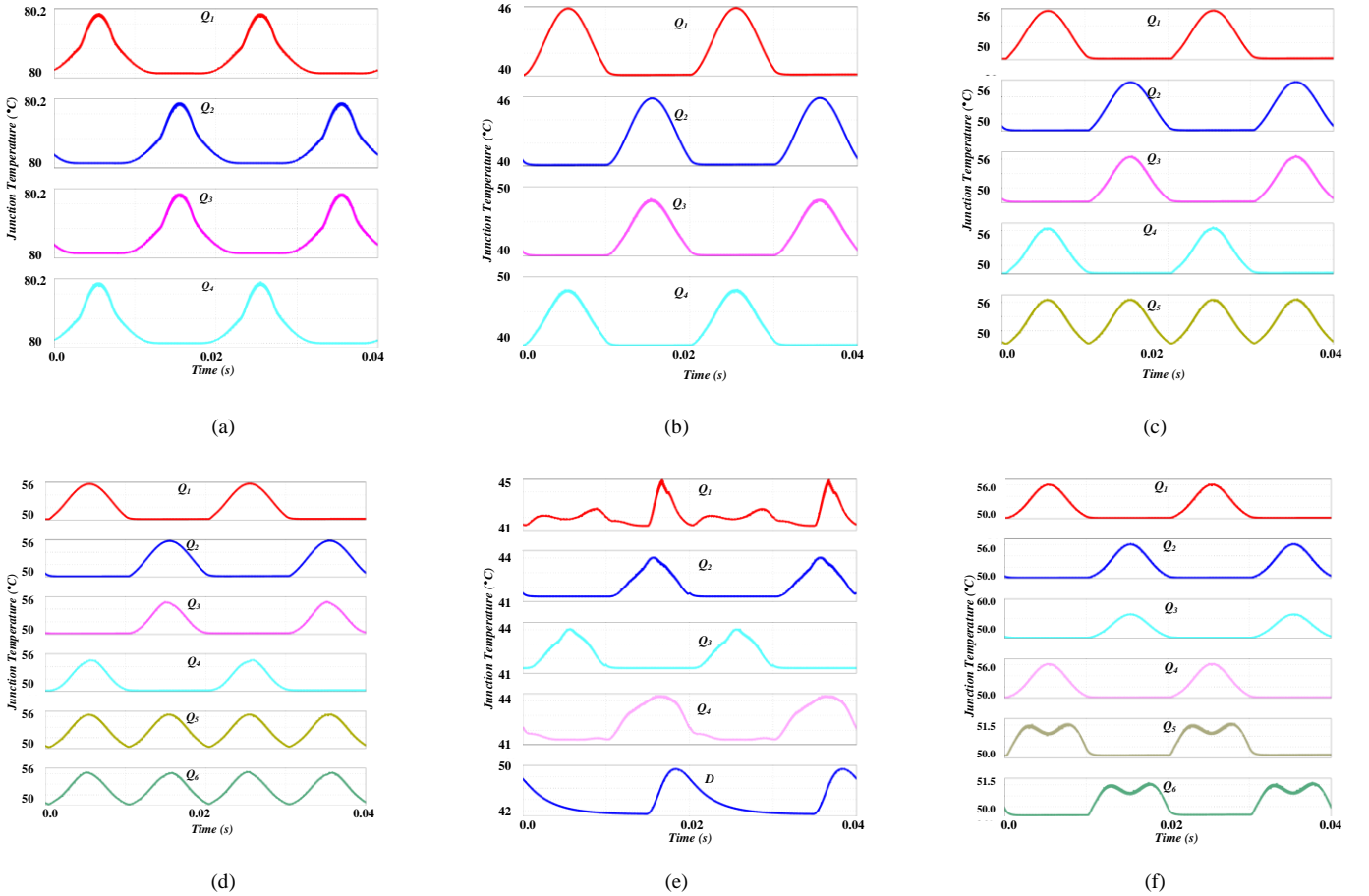



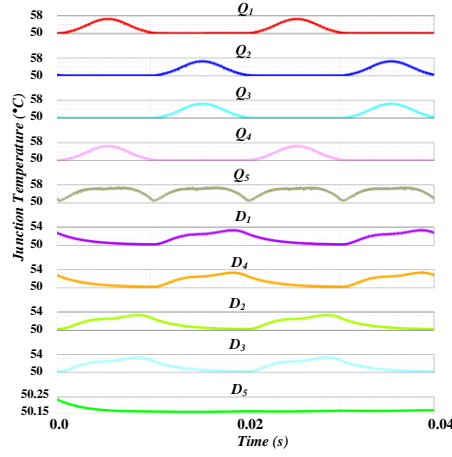

(g)

Fig. 46. Semiconductor devices junction temperature curves in switching intervals, (a) Bipolar F-B topology, (b). Unipolar F-B topology, (c) H5 topology, (d) H6 DC side topology, (e) Topology in [5], (f). HERIC topology, and (g) HB-ZVR topology.

The loss analysis is verified through simulations for seven major topologies using the parameters listed in Table IV. The values of the individual devices are taken from the datasheets [120]-[121]. The power losses of the semiconductor switches are comprised of conduction losses and switching losses. Similarly, for diodes, the power losses comprise conduction and reverse recovery. The mathematical expressions of the losses of IGBT (conduction loss and switch turn-ON/OFF loss) and the diode (conduction loss and reverse recovery loss) are adopted from [110-116]. As discussed, the conduction losses of the semiconductor devices depend on the ON-state voltage  $V_{ON}(t)$ , and the instantaneous current  $i(t)$  [126]-[130].

The conduction losses or the ON-state losses are disclosed in (17) where the inverter fundamental period is  $T$ , and ON-state voltage is  $V_{ON}$  with the instantaneous current  $I_{ce}$  which is the IGBT collector emitter-current.

$$P_{\text{conduction loss}} = \frac{1}{T} \int_0^T (V_{ON}(t) \times I_{ce}(t)) dt \quad (17)$$

The ON-state voltage (18) is the voltage across the collector and emitter; this voltage depends on the internal series resistance ( $r_T$ ). In the time of conduction losses through the antiparallel diode of the switches, the diode current ( $I_D$ ) flows through the internal diode resistance as shown in (19).

$$V_{ON}(t) = V_T(t) + r_T I_{ce}(t) \quad (18)$$

$$V_{ON}(t) = V_D(t) + r_D I_D(t) \quad (19)$$

On the other hand, the conduction losses of the diode occur at the active state through the forward voltage  $V_F$  and freewheeling current  $I_F$  as shown in (20) [35].

$$P_{\text{conduction loss}} = \frac{1}{T} \int_0^T (V_F(t) \times I_F(t)) dt \quad (20)$$

The turn-ON energy losses can be calculated by (21),

$$E_{ON} = E_{ON.T} + E_{ON.FD} \quad (21)$$

where  $E_{ON,T}$  is the switch turn-ON energy without reverse recovery process, and  $E_{ON,FD}$  is the switch turn-ON energy by considering the reverse recovery process. The peak reverse recovery current ( $I_{PRR}$ ) is given in (22),

$$I_{PRR} = \frac{2 \cdot Q_{RR}}{T_{RR}} \quad (22)$$

where  $T_{RR}$  is the reverse recovery time. Now, the diode reverse recovery losses are dependent on the reverse recovery energy  $E_{ON,D}$  and diode voltage at the time of reverse recovery  $V_{RR,D}$ .

$$E_{ON,D} = \frac{1}{4} \times Q_{RR} \times V_{RR,D} \quad (23)$$

For the turn-OFF energy, the reverse recovery effect is negligible. From (18) and (21), the total turn-ON and OFF losses of the switches are obtained by (24).

$$E_T = E_{ON} + E_{ON,FD} + E_{OFF} \quad (24)$$

The total switching losses for the IGBT ( $P_{IGBT,T}$ ) are

$$P_{IGBT,T} = \frac{I}{T} \sum_{n=1}^{f_{sw}} (E_{ON}(n)) + E_{ON,FD}(n) + E_{OFF}(n) \quad (25)$$

where  $f_{sw}$  is the switching frequency. The reverse recovery losses for diode is

$$P_{D,T} = \frac{I}{T} \sum_{n=1}^{f_{sw}} (E_{ON} \cdot D(n)) \quad (26)$$

The total IGBT losses are expressed in (27) for IGBT and (28) for the diode from (20), (23), (25), and (26)

$$\begin{aligned} P_{avg,IGBT\ Loss} &= P_{turn\ ON\ loss} + P_{turn\ OFF\ loss} + P_{conduction\ loss} \\ &= \frac{I}{T} \sum_{n=1}^{f_{sw}} (E_{ON}(n)) + E_{ON,FD}(n) + E_{OFF}(n) + \frac{1}{T} \int_0^T (V_{ON}(t) \times I_{ce}(t)) dt \end{aligned} \quad (27)$$

$$\begin{aligned} P_{avg,Diode\ Loss} &= P_{reverse\ recovery} + P_{conduction\ loss} \\ &= P_{D,T} = \frac{I}{T} \sum_{n=1}^{f_{sw}} (E_{ON} \cdot D(n)) + \frac{1}{T} \int_0^T (V_F(t) \times I_F(t)) dt \end{aligned} \quad (28)$$

From (14) and (27), the total temperature for IGBT losses can be expressed as given in (29), and from (15) and (28), the total temperature for diode losses can be expressed in (30).

$$\begin{aligned} T_{j-IGBT} &= T_H + \left( \frac{I}{T} \sum_{n=1}^{f_{sw}} (E_{ON}(n)) + E_{ON,FD}(n) + E_{OFF}(n) \right) \\ &+ \frac{1}{T} \int_0^T (V_{ON}(t) \times I_{ce}(t)) dt (R_{th-IGBT} + R_{th(ch-IGBT)}) \end{aligned} \quad (29)$$

$$T_{j-diode} = T_H + P_{D,T} = \frac{I_F}{T} \sum_{n=1}^{\frac{f_{sw}}{f}} (E_{ON} \cdot D(n)) + \frac{1}{T} \int_0^T (V_F(t) \times I_F(t)) dt (R_{th-diode} + R_{th(ch-diode)}) \quad (30)$$

The power losses of each semiconductor device of the major transformerless topologies ([5], H5, H6 DC side, HERIC, and HB-ZVR) are shown graphically in Fig. 47. It is clear that the maximum power losses are associated with the FB bipolar topology. On the other hand, the lowest power losses in the semiconductor devices are achieved by the topology in [5] and the HERIC topology.

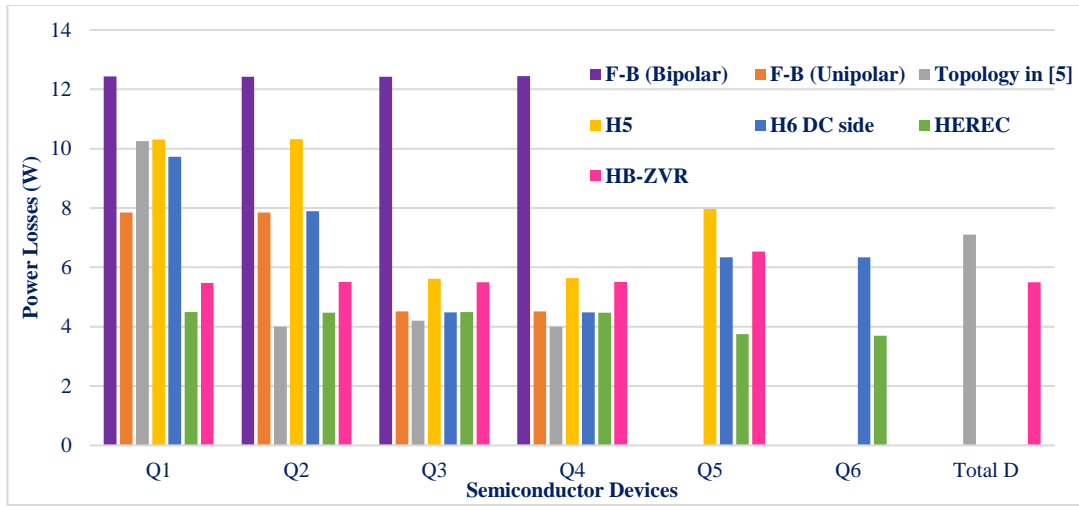

Fig. 47. Comparison of power losses for some of the transformerless inverter topologies for 1.8 kW rated power.

The losses are found for seven selected topologies where only the semiconductor device losses are revealed. Table VII displays the efficiency for different percentages of the output power. To find out the total efficiency, the filter losses have to be considered too.

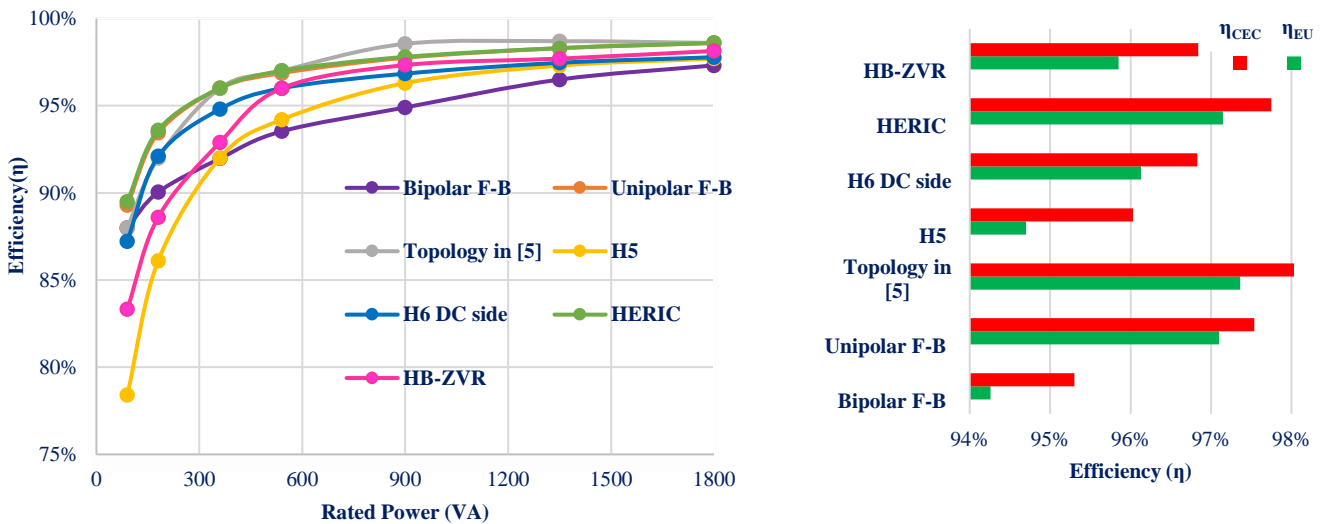

Fig. 48. Efficiency evaluations for major transformerless inverter topologies, (a) efficiency curves vs. output power, and (b) CEC and EU efficiencies.

The maximum efficiency is achieved by the topology in [5] (see Fig. 19 (b)) which is 98.06 % efficiency when selecting California Energy Commission (CEC) weighted efficiencies for calculation formula, and 97.36 % when selecting the European

(EU) weighted efficiencies. The formula for calculating the overall efficiencies are given in (31) and (32) for EU and CEC weighted efficiencies respectively. Fig. 48 illustrates the efficiency curve for different ranges of the output power as well as the overall efficiency.

$$\eta_{EU} = 0.03 \cdot \eta_{5\%} + 0.06 \cdot \eta_{10\%} + 0.13 \cdot \eta_{20\%} + 0.10 \cdot \eta_{30\%} + 0.48 \cdot \eta_{50\%} + 0.20 \cdot \eta_{100\%} \quad (31)$$

$$\eta_{CEC} = 0.04 \cdot \eta_{10\%} + 0.05 \cdot \eta_{20\%} + 0.12 \cdot \eta_{30\%} + 0.21 \cdot \eta_{50\%} + 0.53 \cdot \eta_{75\%} + 0.05 \cdot \eta_{100\%} \quad (32)$$

## V. CONCLUSION

Single-Phase transformerless PV inverters have gained widespread attention due to the low cost/weight and high efficiency compared to single-phase inverters with galvanic isolation. In this paper, CM and  $i_{cm}$  analysis, and output filter design based on ripple factor are presented for single-phase transformerless inverters. Moreover, various single-phase transformerless inverter topologies are reviewed systematically based on their common mode and leakage current behaviour. The main principles of operation and required switching pulses for each topology are presented and compared for each category. Moreover, simulation results for each topology are also presented to give new insight into the understanding of CM and  $i_{cm}$  for safer operation of grid-connected PV system.

Finally, a theoretical power loss modeling and efficiency calculation are provided for major topologies, and an efficiency performance of different topologies is compared numerically. As a summary to this review, Table VI provides a comparative study of main single-phase transformerless inverter categories concerning their major characteristics (i.e., common-mode behaviour, leakage current, efficiency, reactive power transfer capability, component count, and complexity). Overall, the authors hope that this comprehensive review can be a useful resource to help both academic and industry readers comprehend transformerless inverter topologies and identify their respective pros and cons.

TABLE VI  
QUALITATIVE SUMMARY OF THE MAJOR SINGLE-PHASE TRANSFORMERLESS INVERTER TOPOLOGIES.

Transformerless Inverter Topologies	Advantages	Disadvantages	Reactive Power Capability	Size of the Inverter	Efficiency	Recommended Topology
<b>Common Ground Type Topologies</b>	<ul style="list-style-type: none"> <li>▪ No CM effect.</li> <li>▪ Less semiconductor devices are used.</li> <li>▪ Small filter required.</li> </ul>	<ul style="list-style-type: none"> <li>▪ Flying capacitor or switched capacitor or flying inductor controlling is difficult.</li> </ul>	Yes	Small	Very high	Inverter topology in [5]
<b>Mid-Point Clamping</b>	<ul style="list-style-type: none"> <li>▪ Constant CMV and low <math>i_{cm}</math>.</li> </ul>	<ul style="list-style-type: none"> <li>▪ Increased complexity.</li> <li>▪ More semiconductor devices.</li> </ul>	Yes	Large	Medium	HERIC Active 2 [39]
<b>AC-Decoupling</b>	<ul style="list-style-type: none"> <li>▪ Low Conduction losses.</li> <li>▪ Output current is not flowing through the antiparallel diodes of F-B.</li> <li>▪ Lower THD.</li> </ul>	<ul style="list-style-type: none"> <li>▪ Additional switches required.</li> <li>▪ Residual line frequency leakage current.</li> </ul>	Yes	Medium	High	HERIC [31]
<b>DC-Decoupling</b>	<ul style="list-style-type: none"> <li>▪ DC bypass switch helps to disconnect PV from grid during leakage current.</li> </ul>	<ul style="list-style-type: none"> <li>▪ High conduction losses.</li> <li>▪ Additional devices required.</li> <li>▪ Unbalanced switching.</li> </ul>	Yes	Medium	Medium	H5 [32]
<b>H6 Type Topologies</b>	<ul style="list-style-type: none"> <li>▪ Low output current ripple.</li> </ul>	<ul style="list-style-type: none"> <li>▪ Complex control</li> <li>▪ More semiconductor devices.</li> <li>▪ CMV is fluctuated.</li> </ul>	Yes (except H6 with diodes-1 and H6 with diodes-2)	Large	Medium	H6-1 [35]
<b>Buck-Boost Type Topologies</b>	<ul style="list-style-type: none"> <li>▪ Low <math>i_{cm}</math></li> </ul>	<ul style="list-style-type: none"> <li>▪ High THD</li> </ul>	Yes	Large	Medium	Inverter topology in [71]

## REFERENCES

- [1] K. Solangi, M. Islam, R. Saidur, N. Rahim, and H. Fayaz, "A review on global solar energy policy," *Renew. Sustain. Energy Rev.*, vol. 15, no. 4, pp. 2149-2163, May 2011.
- [2] A. Jäger-Waldau, "PV Status Report 2017", [Online]. Available: <https://ec.europa.eu/jrc/en/publication/eur-scientific-and-technical-research-reports/pv-status-report-2017>. JRC Science for policy report, PV Status Report 2017, 2017.
- [3] International Renewable Energy Agency (IRENA), "RE thinking Energy 2017," Accelerating the global energy transformation, 2017.
- [4] T. Kerekes, R. Teodorescu, and U. Borup, "Transformerless photovoltaic inverters connected to the grid," *IEEE Applied Power Electron. Conf. Expo. (APEC)*, Anaheim, CA, May 2007, pp. 1733-1737.
- [5] Y. P. Siwakoti and F. Blaabjerg, "Common-Ground-Type Transformerless Inverters for Single-Phase Solar Photovoltaic Systems," *IEEE Trans. Ind. Electron.*, vol. 65, no. 3, pp. 2100-2111, Mar. 2018.
- [6] V. Sonti, S. Jain, and S. Bhattacharya, "Analysis of the modulation strategy for the minimization of the leakage current in the PV grid-connected cascaded multilevel inverter," *IEEE Trans. Power Electron.*, vol. 32, no. 2, pp. 1156-1169, Feb. 2017.
- [7] S. Dutta, D. Debnath, and K. Chatterjee, "A Grid-Connected Single-Phase Transformerless Inverter Controlling Two Solar PV Arrays Operating Under Different Atmospheric Conditions," *IEEE Trans. Ind. Electron.*, vol. 65, no. 1, pp. 374-385, Jan. 2018.
- [8] Z. Özkan, & A. M. Hava, "A survey and extension of high efficiency grid connected transformerless solar inverters with focus on leakage current characteristics," *In Energy Conversion Congress and Exposition (ECCE)*, Raleigh, NC, Sept. 2012, pp. 3453-3460.
- [9] T. Kerekes, "Analysis and modeling of transformerless photovoltaic inverter systems," *Ph. D. thesis*, Institute of Energy Technology, Aalborg University, 2009.
- [10] H. Xiao and S. Xie, "Leakage current analytical model and application in single-phase transformerless photovoltaic grid-connected inverter," *IEEE Trans. Electromag. Compat.*, vol. 52, no. 4, pp. 902-913, Nov. 2010.
- [11] M. C. Cavalcanti, K. C. De Oliveira, A. M. De Farias, F. A. Neves, G. M. Azevedo, and F. C. Camboim, "Modulation techniques to eliminate leakage currents in transformerless three-phase photovoltaic systems," *IEEE Trans. Ind. Electron.*, vol. 57, no. 4, pp. 1360-1368, Apr. 2010.
- [12] Y. Gu, W. Li, Y. Zhao, B. Yang, C. Li, and X. He, "Transformerless inverter with virtual DC bus concept for cost-effective grid-connected PV power systems," *IEEE Trans. Power Electron.*, vol. 28, no. 2, pp. 793-805, Feb. 2013.
- [13] O. Lopez, R. Teodorescu, F. Freijedo, and J. Doval-Gandoy, "Eliminating ground current in a transformerless photovoltaic application," *IEEE Trans. Energy Conv.*, vol. 25, no. 1, pp. 140-147, Mar. 2010.
- [14] M. Islam, N. Afrin, and S. Mekhilef, "Efficient single phase transformerless inverter for grid-tied PVG system with reactive power control," *IEEE Trans. Sustain. Energy*, vol. 7, no. 3, pp. 1205-1215, Jul. 2016.
- [15] A. Hasanzadeh, C. S. Edrington, and J. Leonard, "Reduced switch NPC-based transformerless PV inverter by developed switching pattern," *IEEE Applied Power Electron. Conf. Expo. (APEC)*, Orlando, FL, Mar. 2012, pp. 359-360.
- [16] Y. P. Siwakoti and F. Blaabjerg, "H-Bridge transformerless inverter with common ground for single-phase solar-photovoltaic system," *IEEE Applied Power Electron. Conf. Expo. (APEC)*, Tampa, FL, May, 2017, pp. 2610-2614.
- [17] IEEE standard conformance test procedures for equipment interconnecting distributed resources with electric power systems, pp.1-54, 2005.
- [18] Power Generation Systems Connected to the Low-Voltage Distribution Network—Technical Minimum Requirements for the Connection to and Parallel Operation With Low-Voltage Distribution Networks, vol. Association for Electrical, Electronic & Information Technologies (VDE), VDE-AR-N 4105-2011, 2011.
- [19] Photovoltaic (PV) Systems—Characteristics of the Utility Interface, vol. International Electrotechnical Commission (IEC), IEC 61727-2004, 2004.
- [20] Recommended Practice for Utility Interface of Photovoltaic Systems, IEEE Std 929-2000, 2000.
- [21] Recommendations for the Connection of Type Tested Small-Scale Embedded Generators (Up to 16A Per Phase) in Parallel With Low-Voltage Distribution Systems, Energy Networks Association (ENA), Engineering Recommendation G83 Issue 2-2012, 2012.
- [22] H. C. Emissions, "Guidelines to the standard EN 61000-3-2," European Power Supply Manufacturers Association, 2010.
- [23] BDEW, Guideline for generating plants' connection to and parallel operation with the medium-voltage network, 2008.
- [24] Technical Requirements for Connecting Photovoltaic Power Station to Power System, vol. Standardization Administration of the P.R.C., GB/T 19964-2012, 2012.
- [25] Grid-Interconnection Code, The Japan Electric Association, JEAC 9701-2012, 2012., 2012.
- [26] D. Meneses, F. Blaabjerg, O. Garcia, and J. A. Cobos, "Review and comparison of step-up transformerless topologies for photovoltaic AC-module application," *IEEE Trans. Power Electron.*, vol. 28, no. 6, pp. 2649-2663, Jun. 2013.
- [27] S. B. Kjaer, J. K. Pedersen, and F. Blaabjerg, "A review of single-phase grid-connected inverters for photovoltaic modules," *IEEE Trans. Ind. Appl.*, vol. 41, no. 5, pp. 1292-1306, Sept-Oct. 2005.
- [28] Characteristics of the Utility Interface for Photovoltaic (PV) Systems, IEC 61727 CDV (Committee Draft for Vote), 2002.
- [29] B. Yang, W. Li, Y. Gu, W. Cui, and X. He, "Improved transformerless inverter with common-mode leakage current elimination for a photovoltaic grid-connected power system," *IEEE Trans. Power Electron.*, vol. 27, no. 2, pp. 752-762, Feb. 2012.
- [30] K. S. Tey and S. Mekhilef, "A reduced leakage current transformerless photovoltaic inverter," *Renew. Energy*, vol. 86, pp. 1103-1112, Feb. 2016.
- [31] H. Schmidt, C. Siedel, J. Ketterer, "DC/AC converter to convert direct electric voltage into alternating voltage or into alternating current," *U.S. Patent No. 7,046,534*. 16 May 2006.
- [32] M. Victor, F. Greizer, S. Bremicker, and U. Hübler, "Method of converting a direct current voltage from a source of direct current voltage, more specifically from a photovoltaic source of direct current voltage, into an alternating current voltage," *U.S. Patent No. 7,411,802*, 2008.
- [33] L. Zhang, K. Sun, Y. Xing, and M. Xing, "H6 transformerless full-bridge PV grid-tied inverters," *IEEE Trans. Power Electron.*, vol. 29, no. 3, pp. 1229-1238, Mar. 2014.
- [34] B. Ji, J. Wang, and J. Zhao, "High-efficiency single-phase transformerless PV H6 inverter with hybrid modulation method," *IEEE Trans. Ind. Electron.*, vol. 60, no. 5, pp. 2104-2115, May 2013.
- [35] M. Islam and S. Mekhilef, "H6-type transformerless single-phase inverter for grid-tied photovoltaic system," *IET Power Electron.*, vol. 8, no. 4, pp. 636-644, Apr. 2015.
- [36] G. San, H. Qi, J. Wu, and X. Guo, "A new three-level six-switch topology for transformerless photovoltaic systems," *IEEE Int. Power Electron. Motion Control Conf.*, Harbin, Jun. 2012, vol. 1, pp. 163-166.
- [37] H. Xiao, S. Xie, Y. Chen, and R. Huang, "An optimized transformerless photovoltaic grid-connected inverter," *IEEE Trans. Ind. Electron.*, vol. 58, no. 5, pp. 1887-1895, May 2011.
- [38] H. Li, Z. Yangbin, Z. Bo, Q. Trillion, H. Ruixiang, and Y. Zhichang, "An improved H5 topology with low common-mode current for transformerless PV grid-connected inverter," *IEEE Trans. Power Electron.*, vol. 34, no. 2, pp. 1254-1265, Feb. 2019.
- [39] W. Li, Y. Gu, H. Luo, W. Cui, X. He, and C. Xia, "Topology review and derivation methodology of single-phase transformerless photovoltaic inverters for leakage current suppression," *IEEE Trans. Ind. Electron.*, vol. 62, no. 7, pp. 4537-4551, Jul. 2015.
- [40] L. Zhang, K. Sun, L. Feng, H. Wu, and Y. Xing, "A family of neutral point clamped full-bridge topologies for transformerless photovoltaic grid-tied inverters," *IEEE Trans. Power Electron.*, vol. 28, no. 2, pp. 730-739, Feb. 2013.
- [41] T. K. S. Freddy, N. A. Rahim, W.-P. Hew, and H. S. Che, "Comparison and analysis of single-phase transformerless grid-connected PV inverters," *IEEE Trans. Power Electron.*, vol. 29, no. 10, pp. 5358-5369, Oct. 2014.
- [42] J. F. Ardashir, M. Sabahi, S. H. Hosseini, F. Blaabjerg, E. Babaei, & G. B. Gharehpetian, "A single-phase transformerless inverter with charge pump circuit concept for grid-tied PV applications," *IEEE Trans. Ind. Electron.*, vol. 64, no. 7, pp. 5403-5415, Jul. 2017.

- [43] Y. P. Siwakoti and F. Blaabjerg, "A novel flying capacitor transformerless inverter for single-phase grid connected solar photovoltaic system," *7th IEEE Int. Symposium on Power Electronics for Distributed Generation Systems (PEDG)*, Aug. 2016 pp. 1-6.
- [44] M. T. Azary, M. Sabahi, E. Babaei, and F. A. A. Meinagh, "Modified Single-Phase Single-Stage Grid-Tied Flying Inductor Inverter With MPPT and Suppressed Leakage Current," *IEEE Trans. Ind. Electron.*, vol. 65, no. 1, pp. 221-231, Jan. 2018.
- [45] D. Karschny, "Flying inductor topology," *DE 196 42 522 CI*, Apr. 23, 1998.
- [46] W. Chen, X. Yang, W. Zhang, and X. Song, "Leakage current calculation for PV inverter system based on a parasitic capacitor model," *IEEE Transactions on Power Electronics*, vol. 31, no. 12, pp. 8205-8217, Dec. 2016.
- [47] T. K. S. Freddy and N. A. Rahim, "Photovoltaic inverter topologies for grid integration applications," in *Advances in Solar Photovoltaic Power Plants: Springer*, 2016, pp. 13-42.
- [48] E. Gubia, P. Sanchis, A. Ursua, J. Lopez, & L. Marroyo, "Ground currents in single-phase transformerless photovoltaic systems," *Progress in photovoltaics: research and applications*, vol. 15, no. 7, PP. 629-650, May 2007.
- [49] A. Kadam and A. Shukla, "A multilevel transformerless inverter employing ground connection between pv negative terminal and grid neutral point," *IEEE Trans. Ind. Electron.*, vol. 64, no. 11, pp. 8897-8907, Nov. 2017.
- [50] Y. Tang, W. Yao, P. C. Loh, and F. Blaabjerg, "Highly reliable transformerless photovoltaic inverters with leakage current and pulsating power elimination," *IEEE Trans. Ind. Electron.*, vol. 63, no. 2, pp. 1016-1026, Feb. 2016.
- [51] Y.-K. Wu, J.-H. Lin, and H.-J. Lin, "Standards and guidelines for grid-connected photovoltaic generation systems: A review and comparison," *IEEE Trans. Ind. Appl.*, vol. 53, no. 4, pp. 3205-3216, Jul.-Aug. 2017.
- [52] Grid Connection of Energy Systems via Inverters Part 1: Installation Requirements, Council of Standards Australia, AS 4777.1-2005, 2005.
- [53] Grid Connection of Energy Systems via Inverters Part 2: Inverter Requirements, Council of Standards Australia, AS 4777.2-2005, 2005.
- [54] Grid Connection of Energy Systems via Inverters Part 3: Grid Protection Requirements, Council of Standards Australia, AS 4777.3-2005, 2005.
- [55] VDE V 0126-1-1, Eigenerzeugungsanlagen am Niederspannungsnetz, 2006.
- [56] R. S. Figueredo, K. C. M. de Carvalho, N. R. N. Ama, & L. M. J. unior, "Leakage current minimization techniques for single-phase transformerless grid-connected PV inverters—An overview," in *Power Electronics Conference (COBEP)*, Brazilian, Oct. 2013, pp. 517-524.
- [57] O. Hashimoto, T. Shimizu, and G. Kimura, "A novel high performance utility interactive photovoltaic inverter system," *Ind. Appl. Conf., Rome*, Aug. 2002, pp. 2255-2260.
- [58] A. Nabae, I. Takahashi, and H. Akagi, "A new neutral-point-clamped PWM inverter," *IEEE Trans. Ind. Appl.*, no. 5, pp. 518-523, Sept.-Oct. 1981.
- [59] X. Yuan, H. Stemmler, and I. Barbi, "Investigation on the clamping voltage self-balancing of the three-level capacitor clamping inverter," *IEEE 30th Annual IEEE Power Electron. Specialists Conf. (PESC)*, Aug. 2002, pp. 1059-1064.
- [60] P. Knaup, International Patent Application, *Pub No. WO 2007/048420 A1* 3 May 2007.
- [61] N. Mohon, T. M. Undeland and W. P. Robbins, *Power Electronics: Converters, Applications and Design*, vol. 2nd ed. New York: Wiley, 1995.
- [62] D. G. Holmes and T. A. Lipo, *Pulse width modulation for power converters: principles and practice*, John Wiley & Sons, 2003.
- [63] W. Yu, J.-S. J. Lai, H. Qian, and C. Hutchens, "High-efficiency MOSFET inverter with H6-type configuration for photovoltaic nonisolated AC-module applications," *IEEE Trans. Power Electron.*, vol. 26, no. 4, pp. 1253-1260, Apr. 2011.
- [64] J. Wang, F. Luo, Z. Ji, Y. Sun, B. Ji, W. Gu, and J. Zhao, "An Improved Hybrid Modulation Method for the Single-Phase H6 Inverter With Reactive Power Compensation," *IEEE Trans. Power Electron.*, vol. 33, no. 9, pp. 7674-7683, Sept. 2018.
- [65] H. F. Xiao, L. Zhang, & Y. Li, "A Family of Zero-Current-Transition Transformerless Photovoltaic Grid-Connected Inverter," *IEEE Trans. power. Electron.*, vol. 30, no. 6, pp. 3156-3165, Jun. 2015.
- [66] H. F. Xiao, L. Ke, Z. Bin, Z. Li, & W. Zaijun, "An improved zero-current-switching single-phase transformerless PV H6 inverter with switching loss-free," *IEEE Trans. Ind. Electron.*, vol. 64, no. 10, pp. 7896-7905, Oct. 2017.
- [67] B. Chen, P. Sun, C. Liu, C. L. Chen, J. S. Lai, and W. Yu, 2012, February. "High efficiency transformerless photovoltaic inverter with wide-range power factor capability," *IEEE Applied Power Electron. Conf. Expo. (APEC)*, Orlando, FL, Feb. 2012, pp. 575-582.
- [68] D. Debnath, and K. Chatterjee, 2016. "Maximising power yield in a transformerless single-phase grid connected inverter servicing two separate photovoltaic panels," *IET Renew. Power Generation*, vol. 10, no. 8, pp. 1087-1095, Sept. 2016.
- [69] I. Patrao, G. Garcerá, E. Figueres, and R. Gonzalez-Medina, "Grid-tie inverter topology with maximum power extraction from two photovoltaic arrays," *IET Renew. Power Generation*, vol. 8, no. 6, pp. 638-648, Aug. 2014.
- [70] A. Anurag, N. Deshmukh, A. Maguluri, and S. Anand, "DC-DC Converter Based Grid-Connected Transformerless Photovoltaic Inverter With Extended Input Voltage Range," *IEEE Trans. Power Electron.*, vol. 33, no. 10, pp. 8322-8330, Oct. 2018.
- [71] W. Wu, J. Ji, & F. Blaabjerg, "Aalborg Inverter-A New Type of "Buck in Buck, Boost in Boost" Grid-Tied Inverter," *IEEE Trans. power electron.*, vol. 30, no. 9, pp. 4784-4793, Sept. 2015.
- [72] J. Roy, Y. Xia, & R. Ayyanar, "High Step-Up Transformerless Inverter for AC Module Applications With Active Power Decoupling," *IEEE Trans. Ind. Electron.*, vol. 66, no. 5, pp. 3891-3901, May. 2019.
- [73] S. L. Kuo, "Half-bridge transistor inverter for DC power conversion," *IEEE Trans. Ind. Electron. Control Instrum.*, no. 4, pp. 249-253, 1974.
- [74] R. González, E. Gubía, J. López, and L. Marroyo, "Transformerless single-phase multilevel-based photovoltaic inverter," *IEEE Trans. Ind. Electron.*, vol. 55, no. 7, pp. 2694-2702, Nov. 2008.
- [75] I. Patrao, E. Figueres, F. González-Espín, and G. Garcerá, "Transformerless topologies for grid-connected single-phase photovoltaic inverters," *Renew. Sustain. Energy Rev.*, vol. 15, no. 7, pp. 3423-3431, Sept. 2011.
- [76] L. Ma, T. Kerekes, P. Rodriguez, X. Jin, R. Teodorescu, and M. Liserre, "A new PWM strategy for grid-connected half-bridge active NPC converters with losses distribution balancing mechanism," *IEEE Trans. Power Electron.*, vol. 30, no. 9, pp. 5331-5340, Sept. 2015.
- [77] M. Calais, V. G. Agelidis, and M. Meinhardt, "Multilevel converters for single-phase grid connected photovoltaic systems: an overview," *Solar Energy*, vol. 66, no. 5, pp. 325-335, Aug. 1999.
- [78] M. Schweizer, T. Friedli, and J. W. Kolar, "Comparative evaluation of advanced three-phase three-level inverter/converter topologies against two-level systems," *IEEE Trans. Ind. Electron.*, vol. 60, no. 12, pp. 5515-5527, Dec. 2013.
- [79] Y. Jiao and F. C. Lee, "New modulation scheme for three-level active neutral-point-clamped converter with loss and stress reduction," *IEEE Trans. Ind. Electron.*, vol. 62, no. 9, pp. 5468-5479, Sept. 2015.
- [80] D. Barater, C. Concarì, G. Buticchi, E. Gurpinar, D. De, and A. Castellazzi, "Performance evaluation of a three-level ANPC photovoltaic grid-connected inverter with 650-V SiC devices and optimized PWM," *IEEE Trans. Ind. Appl.*, vol. 52, no. 3, pp. 2475-2485, May-Jun. 2016.
- [81] I. Staudt, "3L NPC & TNPC Topology," *Semikron. Application note AN11001*, p. 12, 2012.
- [82] L. Ma, K. Sun, and X. Jin, "A transformation method from conventional three phases full-bridge topology to conergy NPC topology," *IEEE Int. Conf. Electrical Machines and Systems (ICEMS)*, Beijing, Nov. 2011, pp. 1-5.
- [83] I. Staudt, "AN-11001: 3L NPC and TNPC topology," *Semikron*, Nuremberg, 2012.
- [84] W. Chen, E. Hotchkiss, & A. Bazzi, "Reconfiguration of NPC multilevel inverters to mitigate short circuit faults using back-to-back switches," *CPSS Trans. Power Electron. Appl.*, Vol. 3, no. 1, pp. 46-55, Mar. 2018.
- [85] E. Samadaei, A. Sheikholeslami, S. A. Gholamian, & J. Adabi, "A square T-type (ST-Type) module for asymmetrical multilevel inverters," *IEEE Trans. power Electron.*, vol. 33, no. 2, pp. 987-996, Feb. 2018.
- [86] M. Pavan, and M. Kumar, "Capacitor voltage balancing and THD analysis in ANPC multilevel inverter." *IEEMA Engineer Infinite Conf. (eTechNxt)*, New Delhi 2018, pp. 1-5.
- [87] M. R. Jannati Oskuee, S. Nikpour, S. Najafi Ravadanegh, & G. B. Gharehpetian, "Improved configuration for symmetric and asymmetric multilevel inverters with reduced number of circuit devices," *Int. J. Ambient Energy*, vol. 39, no. 4, pp. 424-431, Apr. 2017.

- [88] S. K. Biswas, C. Kumar, & T. Maity, "New single-phase multilevel inverter using less elements count," *4th Int. Conf. Recent Advances Inf. Tech. (RAIT)*, DHANBAD Mar. 2018, pp. 1-5.
- [89] J. Jana, H. Saha, & K. D. Bhattacharya, "A review of inverter topologies for single-phase grid-connected photovoltaic systems," *Renew. Sustain. Energy Rev.*, vol. 72, 1256-1270, May 2017.
- [90] B. Burger, "Power electronics for grid connected photovoltaic," in *Proc. Otti Workshop*, pp. 163-216, Jun. 2008.
- [91] J. F. Ardashir, Y. P. Siwakoti, M. Sabahi, S. H. Hosseini, and F. Blaabjerg, "S4 grid-connected single-phase transformerless inverter for PV application," *42nd Annual IEEE Conf. on Ind. Electron. Soc. (IECON)*, Florence, Dec. 2016, pp. 2384-2389.
- [92] Z. Ahmad and S. Singh, "Comparative analysis of single phase transformerless inverter topologies for grid connected PV system," *Solar Energy*, vol. 149, pp. 245-271, Jun. 2017.
- [93] Y. Yang, F. Blaabjerg, and H. Wang, "Low-voltage ride-through of single-phase transformerless photovoltaic inverters," *IEEE Trans. Ind. Appl.*, vol. 50, no. 3, pp. 1942-1952, May-Jun. 2014.
- [94] R. González, J. Lopez, P. Sanchis, and L. Marroyo, "Transformerless inverter for single-phase photovoltaic systems," *IEEE Trans. Power Electron.*, vol. 22, no. 2, pp. 693-697, Mar. 2007.
- [95] R. G. Senosiain, J. C. Calahorra, L. M. Palomo, J. L. Taberna, and P. S. Gorpide, "Single-phase inverter circuit to condition and transform direct current electric power into alternating current electric power," *U.S. Patent Application No. 12/375,644*, 2009.
- [96] Z. Özkan, "Leakage current and energy efficiency analyses of single phase grid connected multi-kVA transformerless photovoltaic inverters," *M. Sc. Thesis*, Middle East Technical University, Turkey, 2012.
- [97] A. Syed, T. K. Sandipamu, and F. T. K. Suan, "High-efficiency neutral-point-clamped transformerless MOSFET inverter for photovoltaic applications," *IET Power Electron.*, vol. 11, no. 2, pp. 246-252, Feb. 2017.
- [98] H. Xiao, X. Liu, and K. Lan, "Optimised full-bridge transformerless photovoltaic grid-connected inverter with low conduction loss and low leakage current," *IET Power Electron.*, vol. 7, no. 4, pp. 1008-1015, Aug. 2013.
- [99] H. Schmidt, S. Christoph, and J. Ketterer, "Current inverter for direct/alternating currents, has direct and alternating connections with an intermediate power store, a bridge circuit, rectifier diodes and a inductive choke," *German Patent DE10*, vol. 221, no. 592, p. A1, 2003.
- [100] S. S. Inverters, [http://www.solaraustralia.com.au/sunways\\_inverter\\_nt2500\\_500\\_series.html](http://www.solaraustralia.com.au/sunways_inverter_nt2500_500_series.html), 2013.
- [101] T. Kerekes, R. Teodorescu, P. Rodríguez, G. Vázquez, and E. Aldabas, "A new high-efficiency single-phase transformerless PV inverter topology," *IEEE Trans. Ind. Electron.*, vol. 58, no. 1, pp. 184-191, Jan. 2011.
- [102] V.-G. Gerardo, M.-R. P. Raymundo, and S.-Z. J. Miguel, "High Efficiency Single-Phase Transformer-less Inverter for Photovoltaic Applications," *Ingeniería, Investigación y Tecnología*, vol. 16, no. 2, pp. 173-184, Apr. Jun. 2015.
- [103] Y. R. Kafle, G. E. Town, X. Guochun, and S. Gautam, "Performance comparison of single-phase transformerless PV inverter systems," *IEEE Applied Power Electron. Conf. Expo. (APEC)*, Tampa, FL, Mar. 2017, pp. 3589-3593.
- [104] E. Afshari, G. R. Moradi, A. Ramyar, R. Rahimi, B. Farhangi, and S. Farhangi, "Reactive power generation for single-phase transformerless Vehicle-to-Grid inverters: A review and new solutions," *IEEE Transportation Electrification Conf. and Expo (ITEC)*, Chicago, IL, Jul. 2017, pp. 69-76.
- [105] S. V. Araújo, P. Zacharias, and R. Mallwitz, "Highly efficient single-phase transformerless inverters for grid-connected photovoltaic systems," *IEEE Trans. Ind. Electron.*, vol. 57, no. 9, pp. 3118-3128, Sept. 2010.
- [106] Z. Ozkan, & A. M. Hava, "Classification of grid connected transformerless PV inverters with a focus on the leakage current characteristics and extension of topology families," *J. Power Electron.*, vol. 15, no. 1, pp. 256-267, Jan. 2015.
- [107] M. Islam, S. Mekhilef, and M. Hasan, "Single phase transformerless inverter topologies for grid-tied photovoltaic system: A review," *Renew. Sustain. Energy Rev.*, vol. 45, pp. 69-86, May 2015.
- [108] B. Liu, M. Su, J. Yang, D. Song, D. He, and S. Song, "Combined reactive power injection modulation and grid current distortion improvement approach for h6 transformer-less photovoltaic inverter," *IEEE Trans. Energy Conv.*, vol. 32, no. 4, pp. 1456-1467, Dec. 2017.
- [109] Z. Ahmad and S. Singh, "Single phase transformerless inverter topology with reduced leakage current for grid connected photovoltaic system," *Electric Power Systems Research*, vol. 154, pp. 193-203, Jan. 2018.
- [110] W. Cui, B. Yang, Y. Zhao, W. Li, and X. He, "A novel single-phase transformerless grid-connected inverter," *37th Annual IEEE Conf. on Ind. Electron. Soc. (IECON)*, Melbourne, VIC, Jan. 2011, pp. 1126-1130.
- [111] W. Cui, H. Luo, Y. Gu, W. Li, B. Yang, and X. He, "Hybrid-bridge transformerless photovoltaic grid-connected inverter," *IET Power Electron.*, vol. 8, no. 3, pp. 439-446, Mar. 2015.
- [112] A. Kumar, & P. Sensarma, "New Switching Strategy for Single-Mode Operation of a Single-Stage Buck-Boost Inverter," *IEEE Trans. Power Electron.*, vol. 33, no. 7, pp. 5927-5936, Jul. 2018.
- [113] X. Guo, "A novel CH5 inverter for single-phase transformerless photovoltaic system applications," *IEEE Trans. Cir. Sys. II: Express Briefs*, vol. 64, no. 10, pp. 1197-1201, Oct. 2017.
- [114] S. Dutta, & K. Chatterjee, "A Buck and Boost Based Grid Connected PV Inverter Maximizing Power Yield From Two PV Arrays in Mismatched Environmental Conditions," *IEEE Trans. Ind. Electron.*, vol. 65, no. 7, pp. 5561-5571, Jul. 2018.
- [115] Y. Xia, J. Roy, & R. Ayyanar, "A capacitance-minimized, doubly grounded transformer less photovoltaic inverter with inherent active-power decoupling," *IEEE Trans. Power Electron.*, vol. 32, no. 7, pp. 5188-5201, Jul. 2017.
- [116] H. Liu, Y. Ran, K. Liu, W. Wang, & D. Xu, "A Modified Single-Phase Transformerless Y-Source PV Grid-Connected Inverter," *IEEE Access*, Vol. 6, pp. 18561-18569, Apr. 2018.
- [117] S. H. Lee, K. T. Kim, J. M. Kwon, & B. H. Kwon, "Single-phase transformerless bi-directional inverter with high efficiency and low leakage current," *IET Power Electron.*, vol. 7, no. 2, pp. 451-458, Feb. 2013.
- [118] Infineon, "Application note 2008-03 Thermal equivalent circuit models," *VI.0*, 2008.
- [119] R. Künzi, "Thermal design of power electronic circuits," *arXiv preprint arXiv:1607.01578*, 2016.
- [120] B. Bai, and C. Dezhi, "Inverter IGBT loss analysis and calculation." *IEEE Int. Conf. Ind. Tech. (ICIT)*, 2013, pp. 563-569.
- [121] N. Ahmad Khan, "Power Loss Modeling of Isolated AC/DC Converter," *Royal Institute of Technology*, 2012.
- [122] A. D. Rajapakse, A. M. G. ole, & P. L. Wilson, "Electromagnetic transients simulation models for accurate representation of switching losses and thermal performance in power electronic systems," *IEEE Trans. Power Del.*, vol. 20, no. 1, pp. 319-327, Jan. 2005.
- [123] A. S. Bahman, K. Ma, & F. Blaabjerg, "A Lumped Thermal Model Including Thermal Coupling and Thermal Boundary Conditions for High-Power IGBT Modules," *IEEE Trans. Power Electron.*, vol. 33, no. 3, pp. 2518-2530, Mar. 2018.
- [124] APT15D60B, data sheet, *Advance Power Technology*.
- [125] IKW30N60DTP, data sheet, *Infineon*.
- [126] C. Marinescu, "Losses comparison for inverters with si and sic devices from pumped storage systems," *Bulletin of the Transilvania University of Brasov. Engineering Sciences. Series I*, vol. 8, no. 2, p. 101, 2015.
- [127] D. Graovac and M. Pürschel, "IGBT Power Losses Calculation Using the Data-Sheet Parameters," *Infineon*, appl. note, vol. 1.1, Jan. 2009.
- [128] J. Rąbkowski and T. Piatek, "A study on power losses of the 50 kVA SiC converter including reverse conduction phenomenon," *Bulletin of the Polish Academy of Sciences Technical Sciences*, vol. 64, no. 4, pp. 907-914, Dec. 2016.
- [129] H. Zhang and L. M. Tolbert, "Efficiency impact of silicon carbide power electronics for modern wind turbine full scale frequency converter," *IEEE Trans. Ind. Electron.*, vol. 58, no. 1, pp. 21-28, Jan. 2011.
- [130] H. Delaram, A. Dasfhan, and M. Norouzi, "Optimal Thermal Placement and Loss Estimation for Power Electronic Modules," *IEEE Trans. Compon. Packag. Manuf. Technol.*, vol. 8, no. 2, pp. 236 - 243, Feb. 2018.