



Aalborg Universitet

AALBORG UNIVERSITY  
DENMARK

## Restoration of a Meshed HVDC Grid with Non-selective Protection Strategy

Zhang, Qi; Liu, Zhou; Chen, Zhe

*Published in:*

2019 IEEE PES Innovative Smart Grid Technologies Asia, ISGT 2019

*DOI (link to publication from Publisher):*

[10.1109/ISGT-Asia.2019.8881366](https://doi.org/10.1109/ISGT-Asia.2019.8881366)

*Creative Commons License*

CC BY-NC-ND 4.0

*Publication date:*

2019

*Document Version*

Version created as part of publication process; publisher's layout; not normally made publicly available

[Link to publication from Aalborg University](#)

*Citation for published version (APA):*

Zhang, Q., Liu, Z., & Chen, Z. (2019). Restoration of a Meshed HVDC Grid with Non-selective Protection Strategy. In *2019 IEEE PES Innovative Smart Grid Technologies Asia, ISGT 2019* (pp. 2422-2427). [8881366] IEEE Press. Innovative Smart Grid Technologies - Asia (ISGT Asia), IEEE <https://doi.org/10.1109/ISGT-Asia.2019.8881366>

### General rights

Copyright and moral rights for the publications made accessible in the public portal are retained by the authors and/or other copyright owners and it is a condition of accessing publications that users recognise and abide by the legal requirements associated with these rights.

- ? Users may download and print one copy of any publication from the public portal for the purpose of private study or research.
- ? You may not further distribute the material or use it for any profit-making activity or commercial gain
- ? You may freely distribute the URL identifying the publication in the public portal ?

### Take down policy

If you believe that this document breaches copyright please contact us at [vbn@aub.aau.dk](mailto:vbn@aub.aau.dk) providing details, and we will remove access to the work immediately and investigate your claim.

# Restoration of a Meshed HVDC Grid with Non-selective Protection Strategy

Qi Zhang, Zhou Liu, Zhe Chen  
Department of Energy Technology  
Aalborg University  
Aalborg, Denmark  
qzg@et.aau.dk

**Abstract**—VSC-HVDC grid can be grouped into two different topologies named radial and meshed. The meshed grid is more flexible, reliable and secure because there are more power flow paths between two or more converters, thus it becomes one of the most potential solutions for the Europe Supergrid. However, the restoration of such a system is still a challenging issue. In this paper, an automatic restoration strategy is presented to recover the grid after a contingency. Compared with other restoration strategies, this strategy has two advantages. First, it has a strong ability to automatically recover the grid system in a shorter time. Second, it realizes the coordination of restoration and grid control strategy thus over or under voltage caused by power imbalance during restoration period is avoided. The effectiveness of the proposed strategy is tested in the PSCAD/EMTDC for a pole fault.

**Index Terms**—Grid Restoration, Meshed HVDC Grid, Master-slave Control, Protection

## I. INTRODUCTION

VSC-HVDC grids can be grouped into two topologies, namely radial and meshed HVDC grids [1]. Compared with the radial topology, meshed HVDC grids have two or more current flow paths between any two terminals as illustrated in Fig.1. It means that in a meshed topology, once a fault occurs in a transmission line, the current flow through the fault line may be changed to another path and power transmission will be recovered in a very short time. This feature makes meshed HVDC grid more flexible, reliable and secure. Hence, a meshed HVDC Grid has become one of the most potential solutions for the Europe Supergrid [1], [2]. However, there still exist some technical challenges which should be solved before a meshed HVDC grid can be used in a practical application.

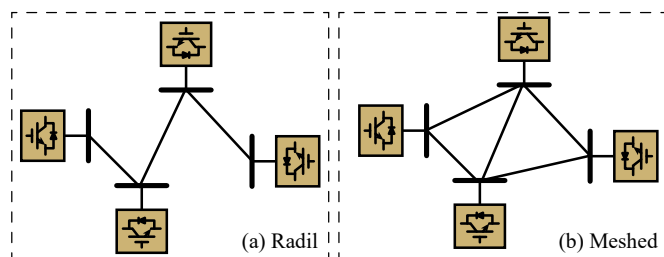

Fig. 1. Different HVDC grid topologies

This Project is funded by China Scholarship Council

One of those challenges is the restoration which focuses on how to recover the power transmission after a contingency is cleared [2]. Once a fault occurs in the DC side of a HVDC system, converters should be blocked in order to protect the switching devices against the high short circuit current; in addition, some breakers or dis-connectors should be opened to isolate the fault. After the fault is isolated or cleared, the restoration controller is used to deal with this condition and recover the power transmission in the health part of the system as soon as possible. Typically, there are three problems considered in the restoration strategy: first, when the restoration controller is enabled to recovery power transmission; second, what are the sequences between de-blocking the MMC converters and re-closing breakers or dis-connectors; third, the recovery sequence of each terminal [5].

There is a strong interaction between restoration and protection strategies because different operation sequences taken by protection leave different conditions for grid restoration. In a non-selective protection strategy [6], AC circuit breakers (ACCBs) connected in the AC side of converters are used to interrupt fault current and DC switchgear devices, such as fast dis-connectors(FDs), are used to isolate the fault in the DC side of grid. That means once a fault is detected, all of the converters are blocked and wait for the isolation of faults, so whole grid will be cut off. It is obvious that this kind of protection strategy is not very desirable due to any faults will result in whole grid cutting off. However, this kind of protection is a cost efficient solution so it is widely used in many particular cable systems.

The restoration strategy on a meshed HVDC grid using ACCBs and FDs to interrupt and isolate faults has been examined in literatures [7]–[9]. A “handshaking” method is presented in [7]. In this method, the opening command are sent to ACCB and FDs to interrupt and isolate the fault when it is detected. However, FDs don’t have the ability to distinguish an arc so they cannot open until current zero crossing happens. That makes the restoration strategy must waiting for FDs’ opening action otherwise the power grid will be connected to an existing fault. In order to avoid this happens, the restoration is set to start after a fixed time delay, 100ms for example. This fixed time delay is left for ACCB and FDs to clear fault. Because the falling speed of fault currents is influenced by other factors, such as fault types, fault location

and so on, the time used to interrupt and isolate the fault is not fix in different faults. Thus, a large time delay should be used here to make sure successfully restoring system. The large time delay makes this restoration strategy inefficient.

In order to overcome this shortcoming, a progress fault isolation and grid restoration strategy [8] is presented, the fixed time delay is replaced by a criterion that whether all of the FDs are open. In the “handshaking” method, only the FDs related to the fault are set to open, but in this method all of the FDs are set to open once a fault is detected. If all of the FDs are open, the converter station is isolated from the grid so that the fault is isolated for a converter. Thus, taking that whether all the FDs are open as a criterion can be used to remove the fixed time delay in “handshaking” method. Although the fixed time delay is removed, this strategy is still not so fast to recover power transmission because opening all of the FDs costs a lot of time.

In addition, there is no coordination between restoration and grid control strategy in those two methods, which may bring voltage and current limit violations due to power imbalance. As we know, in the master-slave control strategy, a voltage-controlled station is mainly responsible for power balancing. Once a PQ-controlled station is de-blocked before a voltage-controlled station, the grid will work without a power balancing control so the power imbalance will appear.

In order to reduce the outage time and recover the grid voltage smoothly, an automatic grid restoration method is presented in this paper for meshed HVDC grids using ACCBs and FDs as protection devices. This method realizes the self-discipline and cooperation between converter stations and faults isolation devices (FDs in this paper) during the restoration period. All of the converters and FDs can automatically de-block and re-close in time by using combinatorial criteria. In this method, it is unnecessary to open all of the FDs, since just the FDs influenced by faults are operated, the outage time is reduced. Furthermore, a coordinate strategy with grid control strategy is considered in this method, so the power imbalance during restoration is avoided. In addition, the over or low voltage issues caused by power imbalance are solved.

## II. FAULT DETECTION AND CLEARANCE

### A. Fault Detection

The fault detection method is realized in a protection system. In the HVDC grids, a DC fault may be detected by the over current and under voltage criterion which is listed below.

$$I_{pn} > Th_I \times I_{normal} \text{ or } |V_{pn}| < Th_V \times V_{normal} \quad (1)$$

where:

- $Th_I, Th_V$ : The thresholds values of over current and under voltage detection, 1.2 – 1.5 for  $Th_I$  and 0.5 – 0.9 for  $Th_V$  [9].
- $I_{pn}$ : The positive or negative pole current value.
- $I_{normal}$ : The rated current value.
- $V_{pn}$ : The voltage between positive and negative poles.

- $V_{normal}$ : The rated voltage between positive and negative poles.

The threshold values in the criterion above are very important values because it directly affects reliability of fault detection. For example, some normal operations will cause an over current in a short time, if the value is too small, the over current caused by normal operation will trigger the protection operation. In addition, the noise and deviation of the measuring equipment also need to be considered into the design of those thresholds. In this paper, current threshold value is set to 1.5, and the under voltage threshold value is set to 0.8.

### B. Fault Discrimination

The fault discrimination method is realized in the restoration controller used to identify whether a FD is dangerous or not. A dangerous FD means this FD is connected to the fault line. For example, in the Fig. 2, there is a fault in Line13, so the FD13 and FD31 are dangerous FDs.

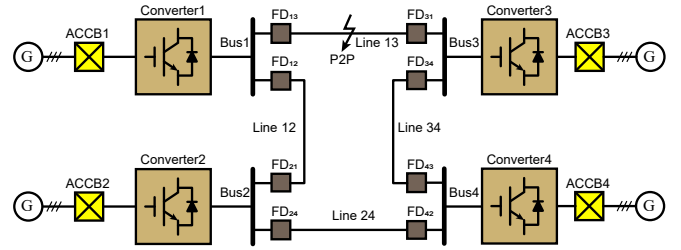

Fig. 2. Selection of dangerous FDs

The criterion used in fault discrimination is listed below:

$$\frac{dI_{FD}}{dt} > DI_{Th} \quad (2)$$

where,  $I_{FD}$  means the current flowing through a FD, which positive direction is from bus to transmission line. If a fault occurs in the line connected to a FD, the current flowing through this FD will increase rapidly, so the current derivative will be far more than the normal value.  $DI_{Th}$  is the threshold value which has an influence on the speed and reliability of fault discrimination. Thus, a suitable value is required to keep the speed and reliability of fault discrimination.

### C. Fault Isolation

The fault isolation is implemented by the coordination between ACCBs and FDs. Once a fault occurs in the grid, all of the converter station will detect this fault then the fault isolation begins. First, an opening command is sent to the ACCB and a blocking command is sent to the converter, parallely. The speed of blocking a converter is very fast, so after blocking the converter, the half bridge type of converter works in a diode rectifier until the ACCB opens successfully. The fault current is fed by AC grid in this period. Second, the restoration controller uses the criterion mentioned in the section II-B to identify the stages of all FDs connected to this converter station, whether a FD is dangerous or safe, and the controller will send an opening command to the FD which

is identified as a dangerous one. Third, The FD, which is identified as a dangerous, opens to isolate the fault at the time when current flowed itself becomes to zero. Due to the capacitor of converter and the distributed capacitance of transmission lines, the current begins to reduce to zero, which waveform looks similar to the phenomenon of capacitive discharge, at the time once ACCB is opened successfully. After all the dangerous FDs are opened successfully, the fault isolation period comes to the end.

### III. GRID RESTORATION STRATEGY

The grid restoration strategy is enabled once fault isolation period comes to end. It is implemented by a restoration controller in each terminal. In order to conveniently introduce the restoration strategy, a terminal which structure is illustrated in Fig. 3 is taken as an example. More detailed signals and the structure of one terminal are given in this figure, which gives a clearer picture for the restoration mechanism realized in one station.

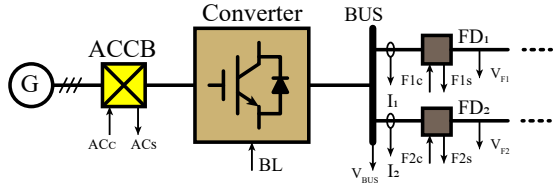

Fig. 3. The structure of a terminal station

In Fig. 3, signals marked  $AC_c, F1_c, F2_c$  means control signals of ACCB and FDs. They are all logical signals, the high level means opening and otherwise means closing. Signals marked  $AC_s, F1_s, F2_s$  are the state of ACCB and FDs. The signal marked  $BL$  is the blocking command input signal of the converter, which a low level is used to block the converter.

The structure of this restoration controller is shown in Fig. 4. It contains four modules, the first one is the state monitor module, the second one is automatic de-block module, the third one is automatic re-close module and the other one is block and deblock operation module.

The state monitor module is used to collect and analysis the information about voltage, current, and the state of converter and FDs. Then that information will be rearranged to different type signals including logical, event, and data signals by the monitor module. Those signals are provided to other modules to create operation sequences.

The block and de-block module is used to create block and de-block operation sequences for the converter. It is designed as an event triggered module in order to simplify the interfaces between different modules. The schematic diagram of this module is shown in Fig. 5, in which it can be seen that this module includes 4 input and 2 output ports which definitions are shown in Table. I. Once the module receives a block event, the converter will be blocked instantly because this event will reset the RS trigger and the Q will be low instantly. And also, an opening logical is sent to ACCB. When the module receives

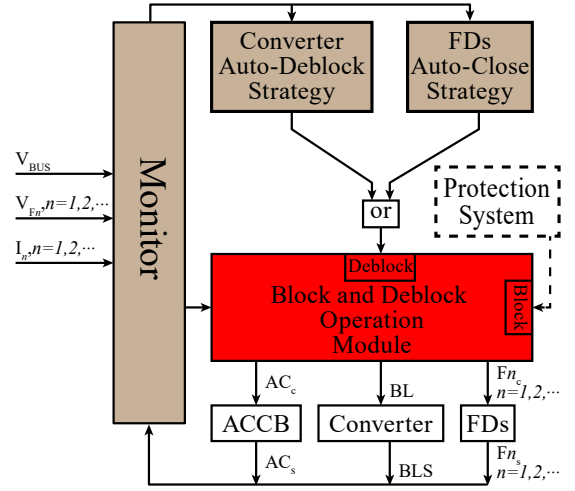

Fig. 4. The schematic diagram of proposed restoration strategy

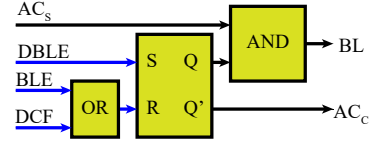

Fig. 5. Blocking and de-blocking operation of a converter

a de-block event, the converter will not de-block instantly because the ACCB must be closed before the converter can be de-blocked, thus a AND gate is used to make sure the ACCB is closed before the de-block operation.

TABLE I  
SIGNALS DESCRIPTION

Name	Type	Description
ACs	Logical	The state of ACCB (opening: Low Level)
DBLE	Event	The event to de-block the converter
BLE	Event	The event to block the converter
DCF	Event	The DC side fault event
BL	Logical	The bolck control signal of converter
ACc	Logical	The input control signal of ACCB

#### A. Auto de-block of converter

The converter is blocked to protect the switching devices against the large short circuit current. After the fault is cleared, the converter should be de-blocked to transmit power as soon as possible. Here a series of criterions are presented, by using which the restoration controller can determine the time to de-block a converter.

The first criterion is whether all of the dangerous FDs have been opened successfully. If they are all opened successfully, a de-block command can be sent to the converter. As mentioned above, once a FD is identified as a dangerous one, an opening command will be sent to it in order to isolate the fault. Because

that all of the dangerous FDs are opened means the fault is isolated successfully, the converter can be de-block directly after all the dangerous FDs have been opened.

The second criterion is based on the bus voltage which is expressed below:

$$V_{BUS} > Th_{BUS} \times V_{normal} \quad (3)$$

When this inequality is satisfied, a de-blocking command can be sent to the converter. If this inequality is not satisfied, the bus voltage can be regarded as recovered, which means the fault is isolated successfully. Thus, the converter can be de-blocked. There are two objectives using this criterion will be detailed below.

The first objective is a supplement to the first criterion. Based on the first criterion, once there exists a FD identified as a dangerous one in the terminal station, the converter can be de-blocked when the dangerous FD is opened. Otherwise, if all the FDs connected to this terminal are identified as safe ones, the first criterion will not work and result in the converter cannot be de-blocked automatically. Thus, the second criterion is introduced here to avoid this phenomenon, as a supplement to the first criterion. The second one is to achieve the coordination of grid restoration and grid power flow control strategy.

The second objective of this criterion is to achieve the coordination of grid restoration and grid power flow control strategy. As we know, in a grid using master-slave control method, the voltage control station must be de-blocked first in order to control the grid voltage, otherwise, over or under voltage will appear in grid due to power imbalance. The coordination of restoration and grid power flow control is utilized by a factor marked as  $Th_{BUS}$  in the criterion. As we know, in order to reduce the shock to power grid, a converter must be re-energized by closing ACCB before it can be de-blocked. During this time, the converter station works in a diode rectifier state and the bus voltage recovers to a lower voltage, so the voltage of grid reaches a diode rectifier voltage. If the factor  $Th_{BUS}$  is larger than the ratio of diode rectifier voltage and normal voltage, this criterion cannot generate a de-block command. Thus, if this converter is a voltage control converter, this factor is set to lower than the ratio of diode rectifier voltage, if it is a P-Q control converter, this factor is set to a larger one, so the voltage control converter will be de-block firstly.

### B. Auto-closing of FD

It should be pointed out that even a FD may be identified as a dangerous one, but in fact, it is really not a dangerous FD as shown in Fig.2, FDs marked as FD21 and FD22 are truly not dangerous ones, but it will be identified as dangerous ones by using the criterion (2). So, after the fault is cleared, those FDs which are mistakenly identified as dangerous ones should be closed in order to recover power transmission. The auto-closing strategy should be used to finish this task.

It is obvious that there are two FDs connected to one transmission line, by using the fault discrimination criterion, only one FD will be identified as dangerous one. Because

based on the Kirchhoff current law, the current run into a line is equal to the current run out of the line, if the line between two FDs is health, so the differential value of two current flowing through FDs are equal and opposite direction. So only one maybe identified as a dangerous one.

Because only one FD connected to a health transmission line may be identified as in danger, so the voltage of this line will recover by the converter connected to the FD which is identified as a safe one. So, the auto-closing of FDs is utilized by this feature. Once the voltage of a transmission line connected to a dangerous FD is recovered, this FD can be closed directly.

## IV. CASE STUDY

### A. Introduction to Simulation Structure

Here a four-terminal meshed HVDC grid as shown in Fig. 6 is used to verify the effectiveness of this auto restoration strategy. The system is configured as symmetrical with a  $400kV$  between two poles. The system parameters can be found in Table. II. The modular multilevel converters (MMC) used here include 38 half-bridge sub-modules in each phase arms, which is refer to the example presented by PSCAD. In order to improve the simulation speed, the detailed equivalent model (DEM) which classified as Type 4 in CIGRE report [10] is used here.

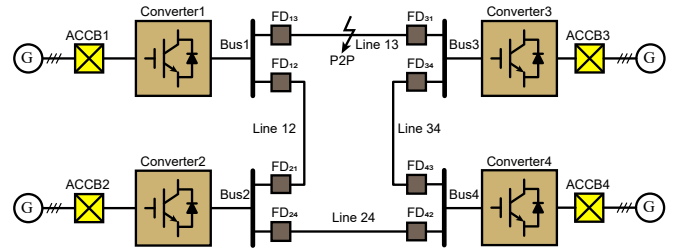

Fig. 6. The grid topology used in simulation

TABLE II  
SYSTEM PARAMETERS

Parameter	Value	Unit
Converter Model	DEM	[-]
DC Voltage	$\pm 200$	[kV]
Sub-modules per Arm	200	[-]
Sub-module resistance(on)	0.908	[m $\Omega$ ]
Converter Arm Inductor	100	[mH]
Link end Inductor	10	[mH]
FD operation Time	10	[ms]
ACCB operation Time	40	[ms]
Link12,13,42,43	200	[km]

The grid power flow control method is master-slave control. In the grid, converter 1 is operated in a voltage control mode and others are operated in P-Q control mode. There is a coordination between grid control method by using a factor marked as  $Th_{BUS}$  in criterion 3, so this factor should be modified by using different grid power flow control method.

The tuning method of this parameter will be developed in the future research.

Due to the non-selective protection strategy is usually used in a system which transmission lines are cables because the whole grid will shut down once a fault is detected and the probability of faults in cable systems is relatively low [8]. The parameters of cables used in simulation are listed in the Table.III, in which:

- :  $r$ : The outer radius.
- :  $\rho$ : The resistivity.
- :  $\epsilon_r$ : The relative permittivity.
- :  $\mu$ : The relative permeability.

TABLE III  
CABLE PARAMETERS

Layer	Material	$r$ [mm]	$\rho$ [ $\Omega$ /m]	$\epsilon_r$ [-]	$\mu$ [-]
Core	Copper	25.2	$1.72 \times 10^{-8}$	1	1
Insulation	XPLE	45.2	-	2.3	1
Sheath	Lead	48	$2.2 \times 10^{-7}$	1	1
Insulation	XPLE	53	-	2.3	1

The model of cables used in simulation is frequency dependent model refer to the basic HVDC example [10] of PSCAD.

In this case, ACCBs are used to interrupt the short circuit current at a voltage zero crossing point of each cycles. So, the time delay from opening command to opening action is not sure. In addition, a pre-inserted resistor is used to start converters softly, which reduces inrush current during the start operation of converter. The pre-inserted resistor is 100 $\Omega$ . This resistor is not a part of this auto-restoration strategy, but it is needed in a high voltage DC grid.

### B. Simulation Results

To verify the effectiveness of the restoration strategy, a pole to pole (P2P) fault is applied in the simulation. The fault occurs at the point 50km away from FD21 in transmission line 21 with 0.5 $\Omega$  impedance. In order to detail the restoration strategy more convenient, the fault isolation and grid restoration strategy is split into different phases. The operation of this restoration strategy will be described in detail in each phase.

The DC bus voltage and line voltage are showed in Figs. 7 - 10. At the 0.8s, a fault occurs in transmission line 12, so the voltage decreases rapidly. The fault can be detected at the time 0.802s, which means the fault detection needs about 2ms, and the converter blocked at about 0.803ms. However, the ACCB will require about 40ms to open, so after the converter is blocked, ACCB is opened successfully about 0.84s. the voltage is hold by the diode rectifier model. Then the FDs identified as dangerous ones are waiting the current flowing through itself to zero so that it can be opened to isolate the fault. At the point 1.0s, the fault is removed so the current on lines became to zero thus all the dangerous FDs open in this time. The fault isolation period is finished.

The current of all the transmission line are shown in Fig.11. Some important operations of converters and FDs are marked

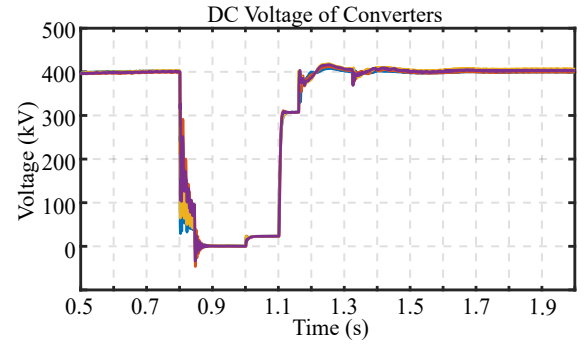

Fig. 7. The DC bus voltage of all the converters

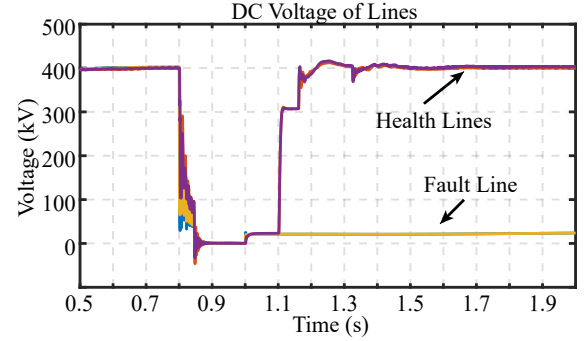

Fig. 8. The DC voltage of all transmission lines

in this figure. Here the presented restoration strategy is split into different phases in order to detail the restoration strategy.

The first phase in this restoration strategy is from about 0.84s, the time ACCB opened, then, the dangerous FDs opened at about 1.0 s. During this time, the restoration is scanning opening or closing states of FDs, once all of the dangerous FDs connected to a bus are opened successfully, the auto-deblocking function enables to deblock converters, which includes two operations, closing the ACCB and de-blocking the converter. In addition, during this phase, the voltage criterion is used to identify whether a deblock command can be created. When the voltage of DC bus of converters is recovered to a set value, the deblock command can be sent to the converter.

The second phase in this restoration is from 1.0s to about 1.16s, when the voltage controller is enabled. During this phase, the auto-closing function for FDs is enabled, which will give information to converters in order to realize the coordination between restoration strategy and grid control strategy which is the master-slave control in this system. It can be seen from the Fig. 11 that the converter is not deblocked at the time ACCB closed. The system is working in a diode rectifier model until the voltage control station has been recovered to a normal model. After the voltage station worked in a normal model, the other stations start.

The third phase in this restoration strategy is from about 1.16s to about 1.35s, the time marked restoration finished in Fig. 11. During this phase, the auto-closing function for FDs are still enabled to determine whether a dangerous FDs can

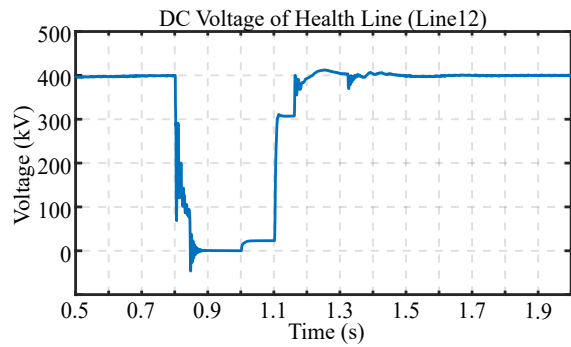

Fig. 9. The DC voltage of a health transmission line (Line12)

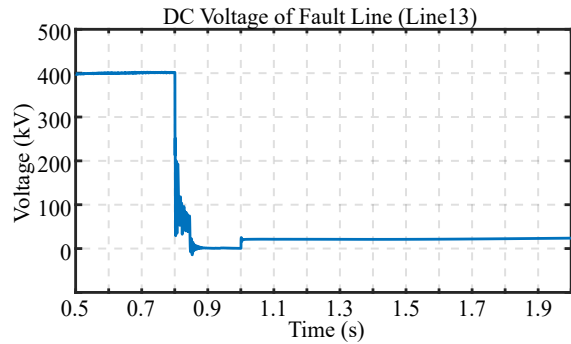

Fig. 10. The DC voltage of a fault transmission line (Line13)

be closed. Because by using this kind of fault discrimination method, some safe FDs can be identified as in danger ones but they should be closed during the restoration strategy.

In a summary, as the voltage of converter dc buses and transmission lines and the current of FDs illustrated in Fig 7-11, this restoration strategy has a strong ability to recover system power transmission. In addition, this strategy utilizes the coordination between restoration and grid control strategy, so there is no over or under voltage happening during the restoration period.

## V. CONCLUSION

An automatic restoration strategy is presented in this paper. This strategy includes four parts which are monitor module, converter auto-deblocking module, FDs auto-close module and the block and de-block operation module for converter. By using the monitor module, this strategy works in a close loop model, which improves the reliability. In addition, by using the line voltage monitoring, the coordination between restoration and grid power flow control strategy can be well developed so this strategy can recover the whole system smoothly and the over or under voltage issues are avoided.

The correctness of the presented restoration strategy is demonstrated by the PSCAD/EMTDC simulation. The simulation result shows that this strategy can recover power transmission automatically and the time costed is about only 0.6s, in addition, due to the coordination of restoration and grid power control strategy, so the over or low voltage caused

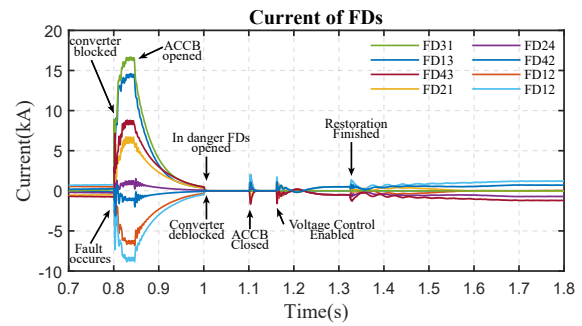

Fig. 11. The current of FDs

by power imbalance is avoided and a higher power quality can be achieved during restoration strategy.

## REFERENCES

- [1] T. M. Haileselassie and K. Uhlen, "Power System Security in a Meshed North Sea HVDC Grid," in *Proceedings of the IEEE*, vol. 101, no. 4, pp. 978-990, April 2013.
- [2] Van Hertem, Dirk, and Mehrdad Ghandhari. "Multi-terminal VSC HVDC for the European supergrid: Obstacles." *Renewable and sustainable energy reviews* 14.9 (2010): 3156-3163.
- [3] Zhang, X. P., R. Zhang, and P. F. Coventry. "Fault management of the MT VSC HVDC using Delayed Auto-Re-Configuration (DARC) schemes," Project Report for National Grid (2011).
- [4] Wang, Puyu, et al. "DC fault management for VSC MTDC system using delayed-auto-re-configuration scheme." (2015): 077-7.
- [5] Wang, Puyu, et al. "Control and protection sequence for recovery and reconfiguration of an offshore integrated MMC multi-terminal HVDC system under DC faults." *International Journal of Electrical Power and Energy Systems* 86 (2017): 81-92.
- [6] CIGRE WG B4/B5-59, "Protection and Local Control of DC Grids," 2017.
- [7] L. Tang and B. Ooi, "Locating and Isolating DC Faults in Multi-Terminal DC Systems," in *IEEE Transactions on Power Delivery*, vol. 22, no. 3, pp. 1877-1884, July 2007.
- [8] R. Dantas, J. Liang, C. E. Ugalde-Loo, A. Adamczyk, C. Barker and R. Whitehouse, "Progressive Fault Isolation and Grid Restoration Strategy for MTDC Networks," in *IEEE Transactions on Power Delivery*, vol. 33, no. 2, pp. 909-918, April 2018.
- [9] "Commission regulation (EU) 2016/1447 of 26 August 2016. Establishing a network code on requirements for grid connection of high voltage direct current systems and direct current-connected power park modules." *Off. J. Eur. Union* 59.L 241 (2016): 1-65. Web.
- [10] CIGRE B4.57 Working Group, "Guide for the development of models for HVDC converters in a HVDC grid," CIGRE, Paris, France, Tech. Rep. no. 604, 2014.