



Aalborg Universitet

AALBORG UNIVERSITY  
DENMARK

## Novel immense configurations of boost converter for renewable energy application

Maroti, Pandav Kiran; Sanjeevikumar, Padmanaban; Blaabjerg, Frede; Ionel, Dan M. ; Wheeler, Patrick

*Published in:*  
The Journal of Engineering

*DOI (link to publication from Publisher):*  
[10.1049/joe.2018.9357](https://doi.org/10.1049/joe.2018.9357)

*Creative Commons License*  
CC BY-NC 3.0

*Publication date:*  
2019

*Document Version*  
Publisher's PDF, also known as Version of record

[Link to publication from Aalborg University](#)

*Citation for published version (APA):*  
Maroti, P. K., Sanjeevikumar, P., Blaabjerg, F., Ionel, D. M., & Wheeler, P. (2019). Novel immense configurations of boost converter for renewable energy application. *The Journal of Engineering*, 2019(18), 4884 - 4889. <https://doi.org/10.1049/joe.2018.9357>

### General rights

Copyright and moral rights for the publications made accessible in the public portal are retained by the authors and/or other copyright owners and it is a condition of accessing publications that users recognise and abide by the legal requirements associated with these rights.

- ? Users may download and print one copy of any publication from the public portal for the purpose of private study or research.
- ? You may not further distribute the material or use it for any profit-making activity or commercial gain
- ? You may freely distribute the URL identifying the publication in the public portal ?

### Take down policy

If you believe that this document breaches copyright please contact us at [vbn@aub.aau.dk](mailto:vbn@aub.aau.dk) providing details, and we will remove access to the work immediately and investigate your claim.

# Novel immense configurations of boost converter for renewable energy application

eISSN 2051-3305  
Received on 6th November 2018  
Accepted on 10th January 2019  
E-First on 1st July 2019  
doi: 10.1049/joe.2018.9357  
www.ietdl.org

Pandav Kiran Maroti<sup>1</sup> ✉, Sanjeevikumar Padmanaban<sup>1</sup>, Frede Blaabjerg<sup>2</sup>, Dan Ionel<sup>3</sup>, Patrick Wheeler<sup>4</sup>

<sup>1</sup>Dept. of Energy Technology, Aalborg University, Esbjerg, Denmark

<sup>2</sup>Center of Reliable Power Electronics (CORPE), Dept. of Energy Technology, Aalborg University, Denmark

<sup>3</sup>Power & Energy Institute of Kentucky (PEIK), SPARK Laboratory, Dept. of Electrical and Computer Engg., University of Kentucky, USA

<sup>4</sup>Power Electronics, Machines and Control Group (PEMC), Dept. of Electrical & Electronics Engg., Nottingham University, UK

✉ E-mail: kiranpandav88@yahoo.co.in

**Abstract:** A three-immense configurations of boost converter for renewable energy application is presented here. The voltage lift switched inductor (VLSI) structure is pledged to extra high-voltage conversion. The proposed work represents the modified high-voltage conversion boost converter (MBC) and its three configuration with VLSI module namely, modified boost converter with XL configuration (MBC<sub>VLSI-XL</sub>), modified boost converter with LY configuration (MBC<sub>VLSI-LY</sub>), and modified boost converter with XY configuration (MBC<sub>VLSI-XY</sub>). The advantages of proposed converter configurations are (i) immense voltage conversion ratio for high-voltage and low-current renewable energy applications; (ii) single switch topologies; and (iii) input inductor to avoid reverse current flow from load to source. The detail mathematical analysis of proposed configurations is carried out with and without considering the internal voltage drop across the circuit components. The comparative investigation is carried out with existed high-voltage conversion ratio topologies. The Matlab simulation results validates the working of proposed MBC configurations.

## 1 Introduction

Nowadays, industrial, transportation, and home appliances are utilising renewable energy sources such as solar, wind instead of conventional energy sources due to various limitation of them [1, 2]. Among the renewable energy sources, photovoltaic (PV) is getting more attraction due to its advantages features. A DC–DC converter is a key intermediate stage between energy conversion process from solar PV (low voltage) to grid or electric vehicle or DC electrical appliances [3].

In last decade, various DC–DC converters are introduced which are having high-voltage conversion ratio capability. The high voltage at output is achieved either by utilising transformer, coupled inductor, voltage multiple unit, or voltage boosting technique. An isolated high-voltage conversion ratio boost converter is presented in [4], which achieve high gain by adopting the transformer in the circuit. The drawback of isolated converter is bulky transformer which increases the circuit size and affects the overall efficiency of the converter. In [5, 6], a non-isolated high gain DC–DC boost converters are presented which achieves required high voltage by adopting coupled inductor and switched capacitor techniques. The advantage of presented topology is single switch which achieve zero current switching to reduce the conduction losses. A new high gain boost converter is proposed in [7], which shows reduced output voltage ripple content, high-voltage conversion ratio, and reduced voltage stress across boost switch accomplish by utilising clamping circuit. A voltage conversion ratio of conventional boost converter is increased by adopting multistage switched inductor technique (SIBC) [8]. One stage of stack increases overall voltage conversion ratio by addition of  $D/(1-D)$ . In [9], a transformer less high gain DC–DC converter is presented. A quadratic boost converter (QBC) is combination of two boost converter connected in series to attain high-voltage conversion ratio [10].

By considering advantage of QBC over conventional boost converter, voltage conversion ratio of QBC is increased by implementing feature of voltage multiplier unit and voltage lift technique. A QBC with voltage multiplier unit at output side and coupled inductor at input side is added to achieve high gain and to reduce the ripple content of input current, respectively [11, 12].

A switched inductor (SI) module is adopted in QBC to achieve high gain [13]. One stage of SI module increase overall voltage conversion ratio by addition of  $D/(1-D)$ . By applying concept of QBC, a modified SEPIC converter (MSC) is derived by cascading of boost and SEPIC converter with single-controlled switch [14]. The voltage conversion ratio of MSC is improved by implementing SI module [15]. The above-discussed topologies are having high-voltage conversion ratio but with high-voltage stress across controlled switch, which decreases the overall efficiency. In [16], a modified SEPIC boost converter with voltage multiplier unit is presented. The presented converters have high-voltage conversion ratio with voltage stress across switch is one-third of output voltage. By considering advantage and disadvantage of discussed high-voltage gain converter, a new family of high-voltage conversion ratio is presented in next section.

## 2 Modified boost converter with VLSI module

The proposed converter configurations are an extension work of MBC and MBC with SI module (MBC<sub>SI</sub>). The MBC is a combination of two conventional boost converter. The MBC<sub>SI</sub> is derived by replacing inductor of MBC by SI module which increase the overall gain by  $(1+D)$  times of conventional boost converter in each configurations. The MBC<sub>VLSI</sub> is derived by replacing inductor of MBC by voltage lift switched inductor (VLSI) module as shown in Fig. 1, which increase the overall voltage conversion ratio by four times of conventional boost converter in MBC<sub>VLSI-XY</sub> configuration. One VLSI module increases the overall voltage conversion ratio by addition of  $(1/(1-D))$  in each boost converter. According to the position of VLSI module on the place of inductor  $L_X$  and  $L_Y$ , the MBC is classified into three configuration as MBC<sub>VLSI-XL</sub> by replacing inductor  $L_X$ , MBC<sub>VLSI-LY</sub> by replacing inductor  $L_Y$ , and MBC<sub>VLSI-XY</sub> by replacing both inductors  $L_X$  and  $L_Y$  by VLSI modules as shown in Figs. 2a–c. The advantages of proposed configurations of MBC are (i) single switch topology; (ii) extremely high-voltage conversion ratio with minimum number of active and passive components; and (iii) input inductor to avoid reverse current flow from load to

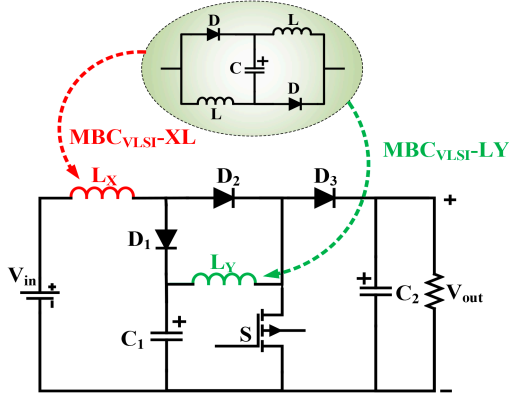

**Fig. 1** Modified boost converter with voltage lift switched inductor module

source side. The number of active and passive components required for each configuration is articulated in Table 1.

The working of proposed converter is same as MBC except VLSI module. In VLSI module, both inductor and capacitor are charges equal to  $V_{in}$  through diodes during conducting state of switch. Two inductors and capacitor are discharged in series with input supply in non-conducting state of switch to boost the output voltage. The working operation of three configuration is nearly same except that at the VLSI module position. For simplicity, working of  $MBC_{VLSI-XY}$  configuration is explained.

### 2.1 Working of $MBC_{VLSI-XY}$ configuration

The operation of  $MBC_{VLSI-XY}$  configuration is separated into two parts as switch ON mode and switch OFF mode as discussed in detail in following sub-section.

- Switch ON mode:** During ON state of switch S, two inductors ( $L_{X1}$  and  $L_{X2}$ ) are energies up to input supply  $V_{in}$  with help of diodes  $D_{X1}$  and  $D_{X2}$ , respectively, and along with diode  $D_2$  and switch S. Similarly, capacitor  $C_X$  charges from  $V_{in}$  via diodes  $D_{X1}$ ,  $D_{X2}$ ,  $D_2$  and switch S as shown in Fig. 3a. In the same way, two inductors ( $L_{Y1}$  and  $L_{Y2}$ ) are energies up to capacitor  $C_1$  via diodes  $D_{Y1}$  and  $D_{Y2}$ , respectively, along with switch S. Capacitor  $C_Y$  charges up to  $V_{C1}$  via diodes  $D_{Y1}$  and  $D_{Y2}$ , respectively, along with switch S. Diode  $D_3$  is in reverse bias due capacitor  $C_2$ . During switch ON mode, output is equals to voltage across capacitor  $C_2$ .
- Switch OFF mode:** During OFF state of switch S, charged inductors  $L_{X1}$ ,  $L_{X2}$  and capacitor  $C_X$  transfer the energy to capacitor  $C_1$  along with input supply  $V_{in}$  via diode  $D_1$  as shown in Fig. 3b. Similarly, capacitor  $C_2$  charges from inductors  $L_{Y1}$ ,  $L_{Y2}$  and capacitor  $C_Y$  along with input supply  $V_{in}$ , inductors  $L_{X1}$ ,  $L_{X2}$  and capacitor  $C_X$  via diode  $D_3$ . In OFF mode, diode  $D_2$  is in reverse bias state.

## 3 Analysis of voltage conversion ratio of proposed MBC configurations with VLSI module

This section deals with detail analysis of voltage conversion ratio of  $MBC_{VLSI-XL}$ , LY, and XY configuration in continuous conduction mode. The analysis is done with and without considering the internal voltage drop of circuit components.

- $MBC_{VLSI-LL}$  Configuration:** The voltage conversion ratio of  $MBC_{VLSI-LL}$  configuration is expressed as [13],

$$V_0 = \frac{1}{(1-D)^2} V_{in} \quad (1)$$

- $MBC_{VLSI-XL}$  Configuration:** Steady-state equations of circuit during CCM are

$$\left. \begin{aligned} V_{LX1} &= V_{LX2} = V_{in} - 2V_{d(L)} - V_{d(D)} - V_{d(S)} \\ V_{CX} &= V_{in} - 2V_{d(L)} - V_{d(D)} - V_{d(S)} \\ V_{LY} &= V_{C1} - V_{d(L)} - V_{d(S)} \end{aligned} \right\} \quad (2)$$

Here,  $V_{d(L)}$  is voltage drop across each inductor due to its internal resistance. Similarly,  $V_{d(D)}$  and  $V_{d(S)}$  are voltage drop across uncontrolled diode and controlled switch, respectively.

To simplify mathematical analysis, the voltage drop across all device are considered as equal

$$V_{d(L)} = V_{d(D)} = V_{d(S)} = V_d \quad (3)$$

$$\left. \begin{aligned} V_{LX1} &= V_{LX2} = V_{in} - 4V_d \\ V_{CX} &= V_{in} - 4V_d \\ V_{LY} &= V_{C1} - 2V_d \end{aligned} \right\} \text{ONstate} \quad (4)$$

(see (5)) By volt second balance law for inductor  $L_X$

$$\int_0^{DT_s} (V_{in} - 4V_d) dt + \int_{DT_s}^{T_s} \times \left( \frac{2V_{in} - V_{C1} - 7V_d}{2} \right) dt = 0 \quad (6)$$

$$V_{C1} = \left( \frac{2}{1-D} \right) V_{in} - \left( \frac{7+D}{1-D} \right) V_d \quad (7)$$

for inductor  $L_Y$

$$\int_0^{DT_s} (V_{C1} - 2V_d) dt + \int_{DT_s}^{T_s} \times (V_{C1} - V_0 - 2V_d) dt = 0 \quad (8)$$

$$V_0 = \frac{V_{C1}}{(1-D)} - \frac{2V_d}{1-D} \quad (9)$$

by (7)

$$V_0 = \left( \frac{2}{(1-D)^2} \right) V_{in} - \left( \frac{9-D}{(1-D)^2} \right) V_d \quad (10)$$

If internal voltage drop is neglected, then voltage conversion ratio is

$$V_0 = \left( \frac{2}{(1-D)^2} \right) V_{in} \quad (11)$$

- $MBC_{VLSI-LY}$  configuration:** Steady-state equations of circuit during CCM are

$$\left. \begin{aligned} V_{LX} &= V_{in} - 3V_d \\ V_{LY1} &= V_{LY2} = V_{C1} - 3V_d \\ V_{CY} &= V_{C1} - 3V_d \end{aligned} \right\} \text{ON state} \quad (12)$$

$$\left. \begin{aligned} V_{LX} &= V_{in} - V_{C1} - 2V_d \\ V_{LY} &= \frac{2V_{C1} - V_0 - 6V_d}{2} \end{aligned} \right\} \text{OFF state} \quad (13)$$

By volt second balance law for inductor  $L_X$

$$\int_0^{DT_s} (V_{in} - 3V_d) dt + \int_{DT_s}^{T_s} (V_{in} - V_{C1} - 2V_d) dt = 0 \quad (14)$$

$$V_{C1} = \left( \frac{1}{1-D} \right) V_{in} - \left( \frac{2+D}{1-D} \right) V_d \quad (15)$$

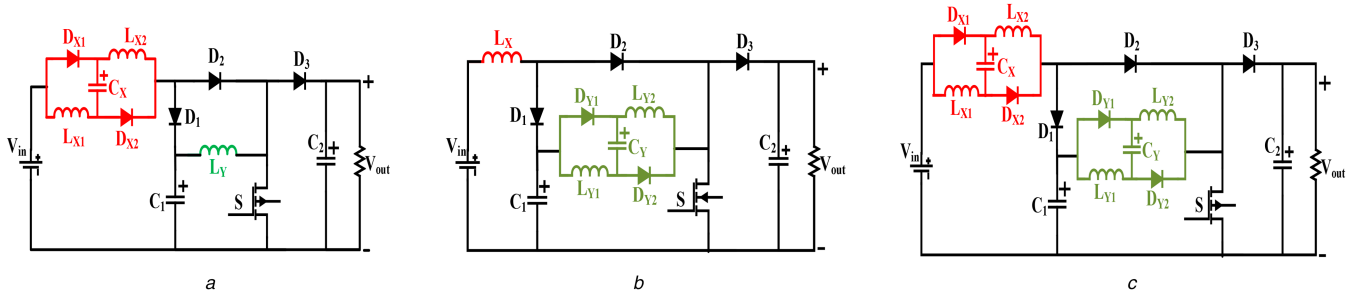

**Fig. 2** Modified boost converter with VLSI module at (a)  $L_X$  position, (b)  $L_Y$  position, (c)  $L_X$  and  $L_Y$  position

**Table 1** Number of components and voltage conversion ratio of proposed converter Configurations

Modified boost converter	Modified boost converter with VLSI module			Voltage conversion ratio	
	$L$	$C$	$D$	$V_{C1}/V_{in}$	$V_0/V_{in}$
VLSI module					
XL	3	3	5	$2/(1-D)$	$2/(1-D)^2$
LY	3	3	5	$1/(1-D)$	$2/(1-D)^2$
XY	4	4	7	$2/(1-D)$	$4/(1-D)^2$

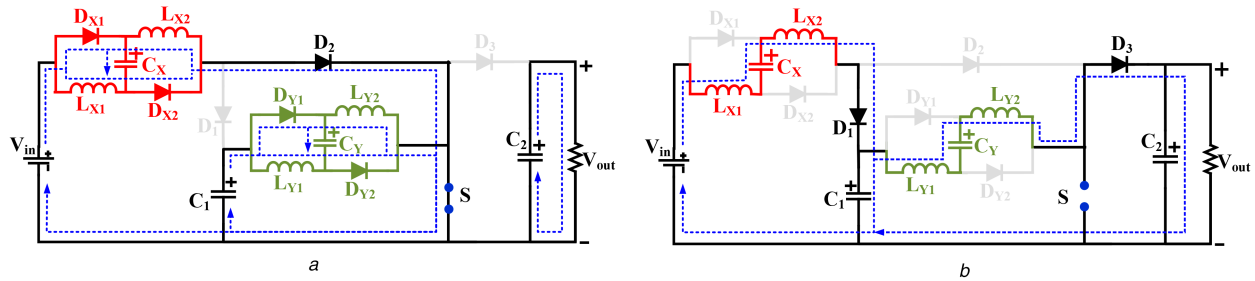

**Fig. 3** Working of  $MBC_{VLSI-XY}$  configuration in (a) Switch ON mode, (b) Switch OFF mode

$$\left. \begin{aligned} V_{LX1} + V_{LX2} &= V_{in} + V_{CX} - V_{C1} - 3V_d \\ V_{LX} &= \frac{2V_{in} - V_{C1} - 7V_d}{2} \\ V_{LY} &= V_{C1} - V_0 - 2V_d \end{aligned} \right\} \text{OFFstate} \quad (5)$$

for inductor  $L_Y$

$$\int_0^{DT_s} (V_{C1} - 3V_d) dt + \int_{DT_s}^{T_s} \frac{(2V_{C1} - V_0 - 6V_d)}{2} dt = 0 \quad (16)$$

$$V_0 = \left(\frac{2}{1-D}\right)V_{C1} - \left(\frac{2}{1-D}\right)V_d \quad (17)$$

From (15)

$$V_0 = \frac{2V_{in}}{(1-D)^2} - \frac{6V_d}{(1-D)^2} \quad (18)$$

If internal voltage drop is neglected, then voltage conversion ratio is

$$V_0 = \frac{2V_{in}}{(1-D)^2} \quad (19)$$

iv.  $MBC_{VLSI-XY}$  configuration: Steady-state equations of circuit during CCM are

$$\left. \begin{aligned} V_{LX1} &= V_{LX2} = V_{in} - 4V_d \\ V_{CX} &= V_{in} - 4V_d \\ V_{LY1} &= V_{LY2} = V_{C1} - 3V_d \\ V_{CY} &= V_{C1} - 3V_d \end{aligned} \right\} \text{ON state} \quad (20)$$

$$\left. \begin{aligned} V_{LX} &= \frac{2V_{in} - V_{C1} - 7V_d}{2} \\ V_{LY} &= \frac{2V_{C1} - V_0 - 6V_d}{2} \end{aligned} \right\} \text{OFF state} \quad (21)$$

By volt second balance law for inductor  $L_X$

$$\int_0^{DT_s} (V_{in} - 4V_d) dt + \int_{DT_s}^{T_s} \left(\frac{2V_{in} - 2V_{C1} - 7V_d}{2}\right) dt = 0 \quad (22)$$

$$V_{C1} = \left(\frac{2}{1-D}\right)V_{in} - \left(\frac{7+D}{1-D}\right)V_d \quad (23)$$

for inductor  $L_Y$

$$\int_0^{DT_s} (V_{C1} - 3V_d) dt - \int_{DT_s}^{T_s} \frac{(2V_{C1} - V_0)}{2} dt = 0 \quad (24)$$

**Table 2** Simulation parameter and value

Parameter	Value
input voltage	10 V
output power	250 W
switching frequency	50 KHz
duty ratio	70%

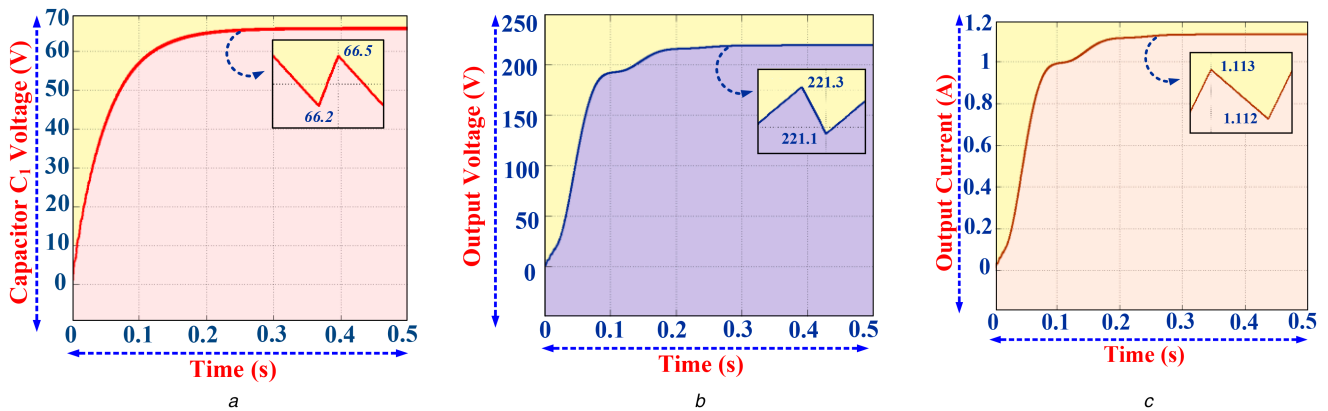
**Fig. 4** Simulation result of  $MBC_{VLSI-XL}$  configuration

(a) Voltage across capacitor  $C_1$ , (b) Output voltage, (c) Output current

$$V_o = \left( \frac{2}{1-D} \right) V_{C1} - \left( \frac{6}{1-D} \right) V_d \quad (25)$$

From (23)

$$V_o = \left( \frac{4}{(1-D)^2} \right) V_{in} - \left( \frac{10-4D}{(1-D)^2} \right) V_d \quad (26)$$

If internal voltage drop is neglected, then voltage conversion ratio is

$$V_o = \frac{4V_{in}}{(1-D)^2} \quad (27)$$

## 4 Result and discussion

To validate the working operation of proposed three configurations of MBC ( $MBC_{VLSI-XL}$ ,  $MBC_{VLSI-LY}$ , and  $MBC_{VLSI-XY}$ ), these converters are simulated in Matlab R2016a with resistive load. All three configurations are simulated at high switching frequency to reduce the components size and output waveform ripple content. The simulation parameters and their value for three configurations are tabulated in Table 2

- $MBC_{VLSI-XL}$  configuration:** The proposed configuration is simulated with resistive load (197.53  $\Omega$ ). Proposed converter is two-stage converter which give intermediate stage voltage of 66.4 V with fluctuation of 0.45% as presented in Fig. 4a. Proposed converter provides 221 V at the output with fluctuation of 0.09% as shown in Fig. 4b. Fig. 4c shows the output current waveform with resultant amplitude of 1.112 A with fluctuation of 1.17%. From Figs. 4b and c, proposed configuration work with 245.97 W power and shows efficiency of 98.38%.
- $MBC_{VLSI-LY}$  configuration:** The proposed configuration is simulated with resistive load (197.53  $\Omega$ ). The intermediate stage voltage of proposed configuration is 33.1 V with fluctuation of 1.2% as presented in Fig. 5a. Proposed converter gives 221.6 V at the output with fluctuation of 0.09% as shown in Fig. 5b. The output current waveform is shown in Fig. 5c which shows the resultant current is 1.114 A with fluctuation of 1.5%. From Figs. 5b and c, proposed configuration work with 247.41 W power and shows efficiency of 98.96%.

- $MBC_{VLSI-XY}$  configuration:** The proposed configuration is simulated with resistive load (788.5  $\Omega$ ). The intermediate stage voltage of proposed configuration is 65.5 V with fluctuation of 0.6% as presented in Fig. 6a. Proposed converter gives 443 V at the output with fluctuation of 0.04% as shown in Fig. 6b. The output current waveform is shown in Fig. 6c which shows the resultant current is 0.555 A with fluctuation of 0.36%. From Figs. 6b and c proposed configuration work with 245.86 W power and shows efficiency of 98.34%. Fig. 7 shows the comparative graph of voltage conversion ratio of three configuration of MBC with VLSI module and cascaded boost converter, conventional boost converter, multistage switched inductor boost converter, and MBC with SI module. It shows that  $MBC_{VLSI-XY}$  configuration is having highest voltage conversion ratio among the MBC family, conventional, and cascaded boost converter. If internal voltage drop is neglected, then  $MBC_{VLSI-XL}$  and  $MBC_{VLSI-LY}$  configuration have same voltage conversion ratio.

## 5 Conclusion

Here, the modified boost converter and its three configuration using VLSI module is discussed. The detail comparative analysis of proposed three converter configurations is carried out with existed high-voltage conversion ratio. The detail mathematical analysis of proposed is carried out with and without considering the internal voltage drop. The  $MBC_{VLSI-XY}$  configuration is having highest voltage conversion ratio as well as lower efficiency in among the other two configurations. The  $MBC_{VLSI-XL}$  and  $MBC_{VLSI-LY}$  configurations have same voltage conversion ratio in ideal condition and  $MBC_{VLSI-XL}$  configurations is having lower efficiency as compared to  $MBC_{VLSI-LY}$  configurations. The detail comparative analysis of three configurations is carried out with respective their voltage conversion ratio and number of components.

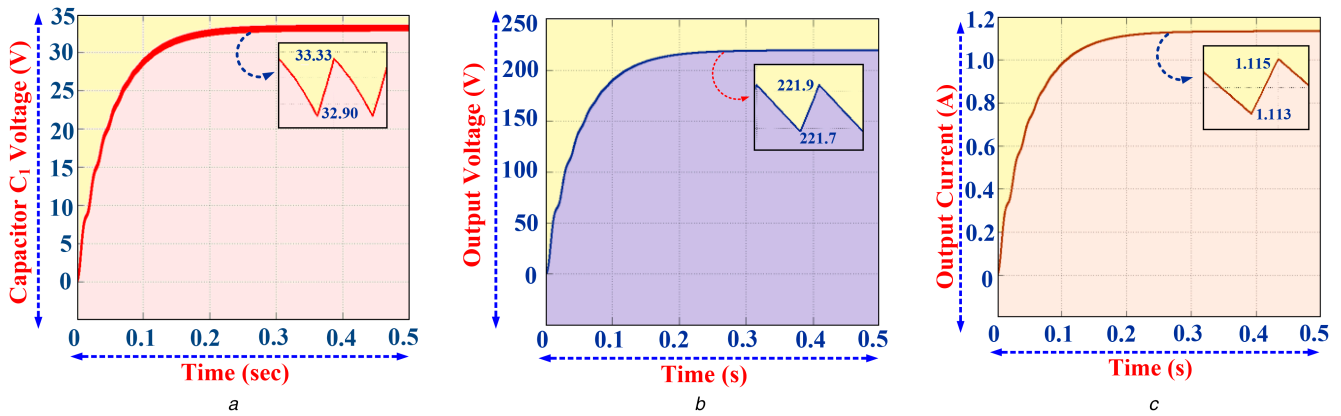

**Fig. 5** Simulation result of  $MBC_{VLSI-LY}$  configuration  
 (a) Voltage across capacitor  $C_1$ , (b) Output voltage, (c) Output current

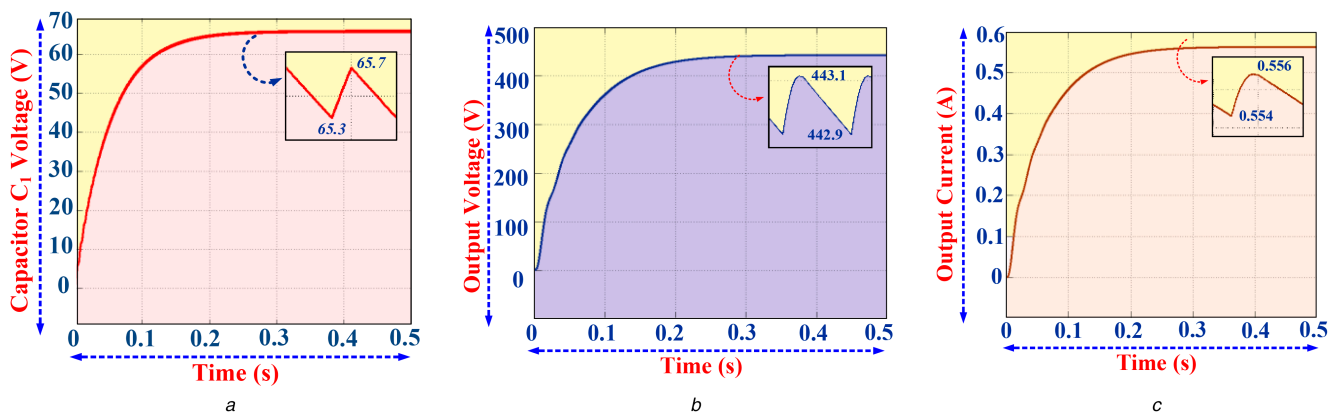

**Fig. 6** Simulation result of  $MBC_{VLSI-XY}$  configuration  
 (a) Voltage across capacitor  $C_1$ , (b) Output voltage, (c) Output current

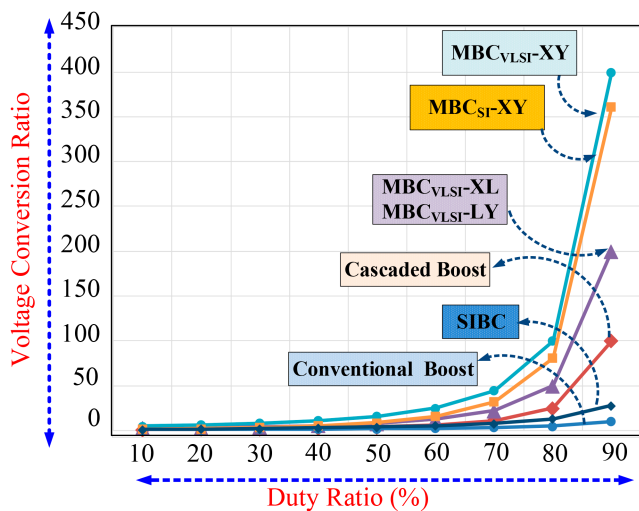

**Fig. 7** Graph of voltage conversion ratio of various boost converter configuration with respective duty ratio

## 6 References

[1] Blaabjerg, F., Yang, Y., Ma, K., *et al.*: 'Power electronics – the key technology for renewable energy system integration'. Intl. Conf. Renewable Energy Research and Applications (ICRERA), Palermo, November 2015, pp. 1618–1626

[2] Sanjeevikumar, P., Grandi, G., Wheeler, P.W., *et al.*: 'A simple MPPT algorithm for novel PV power generation system by high output voltage DC-DC boost converter'. IEEE 24th Intl. Symp. Industrial Electronics (ISIE), Buzios, June 2015, pp. 214–220

[3] Forouzes, M., Siwakoti, Y.P., Gorji, S.A., *et al.*: 'Step-Up DC-DC converters: a comprehensive review of voltage-boosting techniques, topologies, and applications', *IEEE Trans. Power Electron.*, 2017, **32**, (12), pp. 9143–9178

[4] Wu, B., Li, S., Smedley, K.M.: 'A new single-switch isolated high-gain hybrid boosting converter', *IEEE Trans. Ind. Electron.*, 2016, **63**, (8), pp. 4978–4988

[5] Muhammad, M., Armstrong, M., Elgandy, M.A.: 'Analysis and implementation of high-gain non-isolated DC-DC boost converter', *IET Power Electron.*, 2017, **10**, (11), pp. 1241–1249

[6] Schmitz, L., Martins, D.C., Coelho, R.F.: 'Generalized high step-up DC-DC boost-based converter with gain cell', *IEEE Trans. Circuits Syst. I*, 2017, **64**, (2), pp. 480–493

[7] Jain, S., Ritanjali, B., Agarwal, V.: 'High-gain boost converter with coupled inductor and switched capacitor for low voltage renewable energy sources'. Power Electronics, Drives and Energy Systems (PEDES), Mumbai, India, December 2014, pp. 1–6

[8] Maroti, P.K., Sanjeevikumar, P., Bhaskar, M.S., *et al.*: 'Multistage switched inductor boost converter for renewable energy application'. IEEE Conf. Energy Conversion, CENCON'17, Kuala Lumpur, Malaysia, Dec. 2017, pp. 1–6

[9] Rosas-Caro, J.C., Mancilla-David, F., Mayo-Maldonado, J.C., *et al.*: 'A transformer-less high-gain boost converter with input current ripple cancellation at a selectable duty cycle', *IEEE Trans. Ind. Electron.*, 2013, **60**, (10), pp. 4492–4499

[10] Al-Saffar, M.A., Ismail, E.H., Sabzali, A.J.: 'High efficiency quadratic boost converter'. Applied Power Electronics Conf. Exposition (APEEC), Twenty-Seventh Annual IEEE, Orlando, FL, USA, February 2012, pp. 1245–1252

[11] Leyva-Ramos, J., Mota-Varona, R., Ortiz-Lopez, M.G., *et al.*: 'Control strategy of a quadratic boost converter with voltage multiplier cell for high-voltage gain', *IEEE J. Emerging Sel. Topics Power Electron.*, 2017, **5**, (4), pp. 1761–1770

[12] Zhang, N., Sutanto, D., Muttaqi, K.M., *et al.*: 'High-voltage-gain quadratic boost converter with voltage multiplier', *IET Power Electron.*, 2015, **8**, (12), pp. 2511–2519

[13] Maroti, P.K., Sanjeevikumar, P., Wheeler, P., *et al.*: 'Modified boost with switched inductor different configurational structures for DC-DC converter for renewable application'. Southern Power Electronics Conf. (SPEC'17), Chile, December 2017, pp. 1–6

[14] Maroti, P.K., Sanjeevikumar, P., Blaabjerg, F., *et al.*: 'A novel switched inductor configuration for modified SEPIC DC-to-DC converter for renewable energy application'. Conf. Energy Conversion, CENCON'17, Kuala Lumpur, Malaysia, Dec. 2017, pp. 1–6

[15] Maroti, P.K., Bhaskar, M.S., Sanjeevikumar, P., *et al.*: 'A high gain modified SEPIC DC-to-DC boost converter for renewable energy application'. 3rd IEEE Conference on Energy Conversion, CENCON'17, December 2017, pp. 1–6

- [16] Maroti, P.K., Sanjeevikumar, P., Blaabjerg, F.: 'A novel multilevel high gain modified SEPIC DC-to-DC converter for high voltage and low current applications'. Conf. Proc. IEEE 12th Intl. Conf. Compatibility, Power

Electronics and Power Engineering (CPE-POWERENG'18), Doha, Qatar, April 2018