



Aalborg Universitet

AALBORG UNIVERSITY
DENMARK

Large Signal Stability Assessment of the Voltage Source Converter Connected to a Weak Grid

Shakerighadi, Bahram; Ebrahimzadeh, Esmaeil; Bak, Claus Leth; Blaabjerg, Frede

Published in:
Proceedings of CIGRE Symposium Aalborg 2019

Publication date:
2019

Document Version
Accepted author manuscript, peer reviewed version

[Link to publication from Aalborg University](#)

Citation for published version (APA):

Shakerighadi, B., Ebrahimzadeh, E., Bak, C. L., & Blaabjerg, F. (2019). Large Signal Stability Assessment of the Voltage Source Converter Connected to a Weak Grid. In *Proceedings of CIGRE Symposium Aalborg 2019* [18] CIGRE (International Council on Large Electric Systems). https://e-cigre.org/publication/SYMP_AAL_2019-symposium-aalborg-2019

General rights

Copyright and moral rights for the publications made accessible in the public portal are retained by the authors and/or other copyright owners and it is a condition of accessing publications that users recognise and abide by the legal requirements associated with these rights.

- ? Users may download and print one copy of any publication from the public portal for the purpose of private study or research.
- ? You may not further distribute the material or use it for any profit-making activity or commercial gain
- ? You may freely distribute the URL identifying the publication in the public portal ?

Take down policy

If you believe that this document breaches copyright please contact us at vbn@aub.aau.dk providing details, and we will remove access to the work immediately and investigate your claim.

Large Signal Stability Assessment of the Voltage Source Converter Connected to a Weak Grid

**Bahram Shakerighadi, Esmail Ebrahimzadeh, Claus Leth Bak, Frede Blaabjerg
Aalborg University
Denmark**

Accepted

SUMMARY

Voltage source converters (VSCs) are becoming more and more popular in the power electronic-based (PE-based) power systems. Using PE-based units in the system introduces some facilities like more controllability of the system states, while it brings some challenges regarding the stability and reliability of the grid operation. Accordingly, although conventional stability concepts are eligible for the PE-based power systems, it needs more detailed assessment in order to analyze the stability of the VSCs.

Regarding the stability analysis of the grid-connected VSCs, there are a couple of points to be considered. First, an appropriate model of the VSC based on the case study is required. A small signal model of the system using linearization techniques is credible for the small signal assessment, while a large signal model including nonlinear parts of the system is suited when a large signal disturbance happens like when a large such as a big change in the load and this is the subject of the study. Second, as the scale of the PE-based units become large, it is not adequate to model the main grid as a stiff voltage source. Therefore, the main grid will act as a weak grid, which needs a relevant model to be applied to the analysis. Modelling of the weak grid condition is one of the main challenges of the current PE-based power systems, specifically in island power systems with high penetration of distributed.

In this paper, a large signal model of the grid-connected VSC considering the weak grid condition is presented. To do so, the converter is considered as a voltage source in which its output active power can be controlled. Then, in order to evaluate the large signal stability, the nonlinear part of the system should be considered in the model without using the linearization techniques. In order to overcome this challenge, the Lyapunov function of the system is used for the stability assessment. The Lyapunov function is defined based on the VSC parameters, the grid parameter, and the phase angle difference between the VSC and the main grid. It is shown that as long as the proposed Lyapunov function is positive and its derivative with respect to the time is negative, the system works in its stable mode.

To verify the proposed model, time domain simulations are considered for a grid-connected VSC. In the case studies, the DC-link voltage of the VSC is considered to be constant for the sake of simplicity and in order to focus on the proposed method. It is shown that the stability boundaries can be predicted by using the proposed model, and the proposed method is valid both for the small signal and large signal stability assessments.

KEYWORDS

Power electronic stability, Grid-connected voltage source converters, Large-signal stability assessment, Lyapunov stability analysis.

1. Introduction

Dealing with large disturbances in the power system, such as line faults and generator losses, have always been of which interest and also a challenge to researchers and system operators of the electrical grids [1], [2]. What keeps some methods impractical in this manner is the time scale of the assessment [3], [4]. This is because these methods are time consuming, while the case studies need near real-time actions.

Generally, grid faults need to be determined, analysed, and cleared with in a small amount of time [5], [6]. On the other hand, large disturbances that include nonlinear phenomena such as lightning make the challenges more complicated [7], [8]. These large disturbances affect the stability of the system. In case that a fault stays more than a specific time, then a part of the system or the whole system may get out of order as a blackout case. The research related to this topic are categorized as the large signal stability assessment [9]–[12].

The topic of large signal stability is a well-matured analysis technique in the power system literature [13]. On the other hand, as the power electronic-based (PE-based) units increases in the system, the scope of the stability assessment has been changed [11], [13]. As the penetration of the PE-based units increases in the system, the hierarchical structure of the power systems change into a more distributed one. In the new scope of the restructured power systems, more detailed control systems are also used in order to increase the controllability of the system state variables. This may make the system more vulnerable to the system perturbations [14], [15].

Regarding the stability of the PE-based power systems, many models have been developed in order to emulate the behavior of the real system [8], [16]. Most models regarding the grid connected VSC's are developed based on linearization, which are mostly credible for small disturbances and around one specific operation point [16]. Stability assessment techniques for the linear (or linearized) systems are well-developed in the literature. The main objective in the small signal stability assessment is to determine the stability burden. Afterwards, it is important to determine how far the operating point is from the stability margin. Do to so, frequency-domain stability methods, such as Nyquist stability criteria and Bode plot, can be used [16], [17]. On the other hand, when the system is subjected to a large disturbance, such as a large change in the load or a loss of generation, it is not accurate enough. The large signal stability assessments, such as the Lyapunov stability method and the phase portrait, are developed to analyze the system stability when the system is subjected to a large disturbance [12], [18], [19]. The main advantage of these systems compared with the small signal assessment methods is that they are capable to determine the stability of nonlinear systems. Therefore, it is not necessary to linearize the system model. While more accurate stability margin can be determined when using the large signal stability methods compared with the small signal stability methods when the system is subjected to a large disturbance, there is no straightforward method to determine the stability margin based on the large signal methods. For instance, the Lyapunov function can be defined in infinite ways, and there is no guarantee if one can apply it to different system topologies [20]. In this way, some authors have tried to define a step-by-step method in order to evaluate the large signal stability of the grid connected VSC [11], [12]. Although, these methods are doubt to be expandable for more complex systems with more detailed components. This is because the stability analysis becomes much more complex when the order of the system increases.

In this paper, a Lyapunov function is defined to be used for large signal stability analysis which is based on the synchronous generator equivalent of the VSC. As the Lyapunov function is well-developed for the synchronous generator, the equivalent model can be applied for the VSC. To do so, first, the behavior of the grid-connected VSC is modeled as its synchronous generator equivalent. Then, the Lyapunov function defined for the SG will be applied for the VSC. Although the control system of the VSC may not include a moment of inertia, it is shown that this can be determined based on its swing equation. Results show that the stability margin of the grid-connected VSC can be determined based on its Lyapunov function.

The rest of the paper is organized as follows: In Section 2, the basic concept of the Lyapunov function stability and its use in determining the stability burden in the conventional power systems is discussed. Then in Section 3, the large signal model of the grid-connected VSC based on its Lyapunov function is presented. In Section 4, simulation results will be reported in order to validate the proposed method. The paper is concluded in Section 5.

2. The Lyapunov function stability for the power system

A well-known method to analyze the large signal stability of a system is to monitor its energy function behavior. The energy function or the Lyapunov function of a system is a function in which the total physical (or semi-physical) energy of the system including the kinetic and potential energies are considered. The main idea in the assessment of the stability of a system using its energy function is that a stable system includes a positive energy that decreases to a certain value. Therefore, the derivative of the energy function of a stable system with respect to the time is negative. This concept is valid for a system subjected to both the small perturbations and the large disturbances. The concept of the Lyapunov function is generalized in respect to the linearization; therefore, the method is valid for non-linear systems. The non-linear behavior of the PE-based power systems with respect to large disturbances makes the Lyapunov function method a good candidate for the assessment of the large signal stability. The main challenge in using the mentioned method is to define an appropriate energy function that express the system behavior. This concept is well- developed for the conventional power systems. Therefore, in this section, the basic concept of the Lyapunov function will be discussed for a simple model of a generator ($V_{Gen} \angle \delta$) connected to the grid ($V_{Grid} \angle 0$); which is illustrated in Fig. 1.

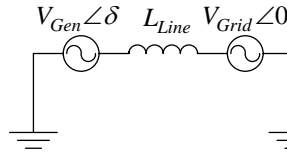

Fig. 1. A simplified model of the grid-connected synchronous machine.

The active and reactive power injected from the generator to the grid can be calculated as follows:

$$\begin{cases} P = \frac{V_c V_g}{X_L} \sin(\delta) \\ Q = \frac{V_c^2}{X_L} - \frac{V_c V_g}{X_L} \cos(\delta) \end{cases} \quad (1)$$

where P and Q are the active and reactive power injected to the grid, respectively. X_L is the line impedance with respect to its inductance (L_{Line}) and the system fundamental frequency (f_0). X_L is equal to $(2\pi f_0 L_{Line})j$. Considering the swing equation of the synchronous generator in eq. 2, a change in the system configuration can make a change in the phase angle δ [11].

$$\frac{2H}{\omega_0} \frac{d^2 \delta}{dt^2} = P_m - P_{\max} \sin(\delta) \quad (2)$$

where $P_{\max} = \frac{V_c V_g}{X_L}$ is the maximum transferable active power and the P_m is the mechanical active

power of the synchronous machine. In addition, H is the inertia constant in MWs/MVA. It is worth mentioning that this is a simplified model of the synchronous generator without considering the damping factor and more dynamic details of the system such as Power System Stabilizer (PSS), exciter, and Automatic Voltage Regulator (AVR). Although by using detailed model of the system, more accurate results can be accomplished, this is out of the scope of the paper. Therefore, without losing the generality of the proposed method, only the simplified model of the synchronous machines is considered.

To evaluate the system stability, a scenario is defined as follows. Increasing the grid impedance X_L caused by disconnecting one line in paralleled lines will make a decline in the

instantaneous active power. This scenario is shown in Fig. 2 (considering X_{L2} is disconnected from the system), and the respectively active power curves are as shown in Fig. 3 (a). As it can be seen from the Fig. 3 (a), first, the system works in its stable equilibrium point a with active mechanical power P_m and the same electrical active power. Then, by disconnecting one of the lines, the maximum transferable active power decreases. In addition, the instance of active power decreases after disconnecting one of the lines illustrated as, point b with electrical active power P_1 . As the mechanical power of the synchronous generator stands still, the difference between the mechanical and the electrical active power makes acceleration of the phase angle δ . Therefore, the electrical active power increases until it reaches the mechanical active power at point c with electrical active power P_2 . After that, the phase angle will continue increasing until the kinetic energy released from the point b to c . If this happens before the point d , then the system operating point will come back to point c (Fig. 3 (a)). Otherwise, the system will become unstable (Fig. 3 (b)).

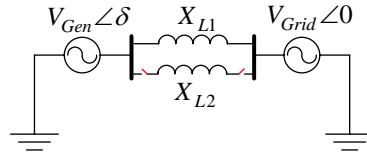

Fig. 2. A simplified model of the grid-connected synchronous generator when one of the tie lines is disconnected from the system.

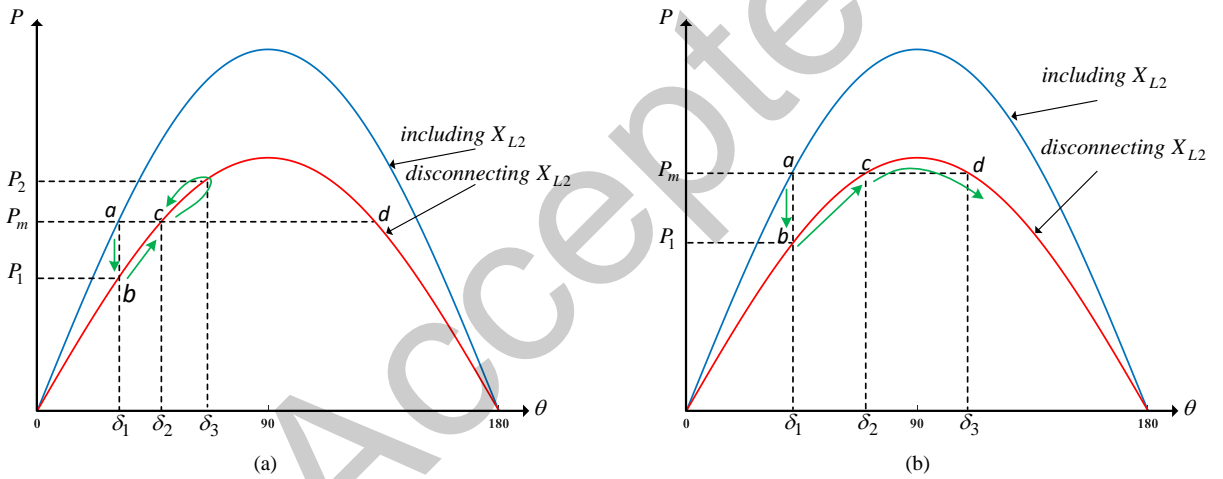

Fig. 3. The synchronous machine's active power versus phase angle (a) when there is an equilibrium point and (b) without an equilibrium point, when the system subjected to a large disturbance (changing the grid side impedance value).

Staying stable after system configuration change will be dependent on the ability of the system to absorb the kinetic energy released after the change. The total energy of the system including the kinetic and the potential energy of the system, called the energy function of the system, is introduced as follows in order to evaluate the system stability.

$$V(\delta, \omega) = \frac{H}{\omega_0} \omega^2 - P_m (\delta - \delta_2) - P_{\max} (\cos(\delta) - \cos(\delta_2)) \quad (3)$$

Both δ and ω are variables with respect to the time, while other parameters have constant values. It can be determined that for a stable condition, the energy function is positive and its derivative with respect to the time is negative.

$$\begin{cases} V(\delta, \omega) \geq 0 \\ \frac{\partial V(\delta, \omega)}{\partial t} \leq 0 \end{cases} \quad (4)$$

It can be concluded that if the kinetic energy released after the system change absorbs by the system, then the system remains stable. This can be shown mathematically as follows:

$$\frac{H}{\omega_0} \omega^2 \leq P_m (\delta_3 - \delta) + P_{\max} (\cos(\delta_3) - \cos(\delta)) \quad (5)$$

The aforementioned equations are calculated based on the dynamic response of the synchronous generator. This can also be used for other systems including a moment of inertia. In the next part, a large-signal model for the VSC is presented, in which the inertia of the VSC is considered. Therefore, an equivalent model of the synchronous machine can be used for the VSC. By using the equivalent model, the large-signal stability of the VSC is assessed and the stability margin is calculated.

3. Large-signal modelling of the grid-connected VSC

In this part, first, a model of the grid-connected VSC is presented. Then, based on the presented model, the energy function model is developed in order to evaluate the large signal stability of the system. In this way, a grid-connected VSC as shown in Fig. 4 is considered as the system under study. The dc-link of the VSC is considered to be constant. Although the dynamic of the dc-link control system may affect the stability margin, this is not the focus of the paper. Therefore, it is considered to have a constant value.

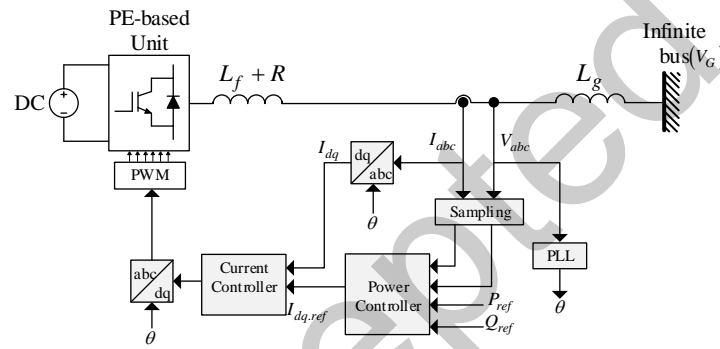

Fig. 4. A general schematic of the grid-connected VSC in grid feeding form with an active power control loop and a current control loop.

While there are some proposal for controlling the active power and the current, a well-accepted controller is the proportional-integral (PI) controller. Therefore, in both the active power controller and the current controller, the PI controller is used. The block diagram of the power loop and current loop controls are shown in Fig. 5. In order to decouple the d and q control, decoupling terms are added into current controllers. For the sake of simplicity, reactive power control is not considered in this paper.

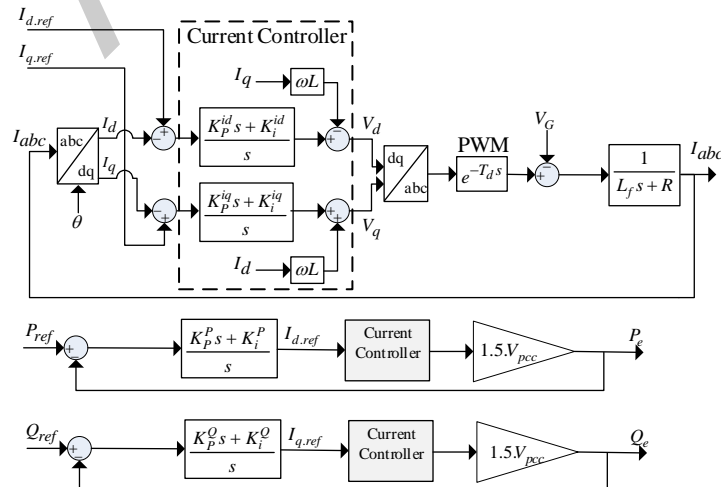

Fig. 5. Detailed model of the active power control loop and the current control loop.

A rule of thumb, the outer control loop should be 5-10 times faster than the inner loop in order to be not affected by the inner loop dynamic response. With this in mind, the power control loop, as an outer loop, is considered to be ten times slower than the current control loop.

On the other hand, in order to transfer the measured voltage and current from abc stationary frame into the dq rotational frame, the phase angle is needed. To determine the phase angle of the voltage, a PLL should be used. The block diagram of a conventional synchronous reference frame phase-locked loop (SRF-PLL) used to extract the phase angle of the output voltage of the converter is shown in Fig. 6.

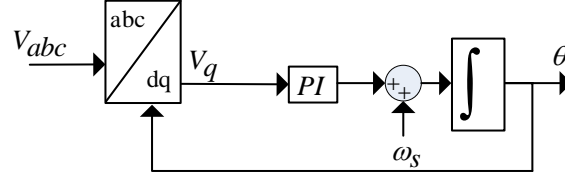

Fig. 6. The PLL control schematic for performing grid synchronization.

The dynamic response of the PLL affects the stability of the system, yet this are not be considered in this paper, as it is beyond the scope of this work, but an issue to have careful attention at. Although it is worth mentioning that other nonlinear terms such as current and voltage limiters are eliminated from the modeling part, without losing any generality of the proposed method.

Considering the aforementioned model of the grid-connected VSC, the next step is to define the Lyapunov function of the system in order to determine the stability margin. In this step, the general concept of the synchronous generator and the swing equation are used. Obviously, every physical object has a moment of inertia, which is dependent on its mass and the form of the force applied to the object. With this in mind, the grid-connected VSC, as a physical object, has an inertia given by its energy storage, and it reacts to external force applied to it based on its inertia. Considering this fact, the swing equation and the related Lyapunov function in eq. 2 can be used for the system.

$$\frac{1}{2} M \frac{d^2 \delta}{dt^2} = P_m - P_{\max} \sin(\delta) \quad (6)$$

where M is the moment of inertia of the grid-connected VSC. The M is very dependent on the configuration of the control system. Mostly, for the virtual synchronous machine control system of the VSC, the value of the M can be determined directly. Yet, in this paper, it is shown that for the conventional PI control of the active power, the system still acts as it has an inertia. With this in mind, the following equation is considered as the energy function of the VSC:

$$V(\delta, \omega) = \frac{1}{2} M \omega^2 - P_{ref} (\delta - \delta_2) - P_{\max} (\cos(\delta) - \cos(\delta_2)) \quad (7)$$

where P_{\max} and P_{ref} are the maximum and the reference active power of the VSC, respectively. In (7), M and ω are assumed as constant values. In the simulations and discussion part of this paper, it is shown that the stability status of the system can be monitored by tracking the Lyapunov function of the system.

4. Simulation results and discussion

In order to evaluate the proposed method, a single grid-connected VSC is considered as the case study. The information of the VSC is mentioned in Table I. The impedance value of the grid is considered to be variable with respect of the weakness of the grid. By increasing the impedance value of the grid, the capability of the main grid in controlling the state variables of the point of common coupling (PCC) becomes less. Therefore, in order to evaluate the effect of the weak grid, a larger value of the L_g is considered.

TABLE I. SYSTEM PARAMETERS FOR THE GRID-CONNECTED VSC.

System parameter	Value	Explanation
L_f	10 mH	An L filter is considered in the output of the system in order to smooth the system output current.
L_g	0 mH-30 mH	The L_g is variable based on the weakness of the main grid.
V_{grid}	400 V (rms phase to phase)	An ideal three-phase voltage source is used for the simulation of the grid equivalent.
System frequency	50 Hz	$\omega = 100\pi$ rad/sec
T_s	10^{-4} s	The sampling frequency is 10 kHz.
S_n	10 kVA	
V_n	400 V	

In this section, three scenarios are studied. In the first two scenarios, it is shown that when the system works in its stable mode, the energy function and its derivative with respect to the time is positive and negative, respectively. In the third scenario, the stability margin is determined, and it is shown that when the energy function derivative with respect to the time is equal to zero, then the system works on the marginal point of the stability. As the control system is controlled by a first order active power controller, then it cannot become unstable. In the third scenario, it is also shown that if there is no equilibrium point, then the energy function derivative with respect to time is zero.

A. Scenario 1: Increasing the active power reference

In this scenario, by increasing the active power reference, the output active power will increase. The active power reference is increased from 4 kW to 10 kW. The output active power of the VSC will follow the reference power, and as the maximum active power P_{max} is 15 kW, the system converges to its new equilibrium point. The maximum active power, the reference active power and

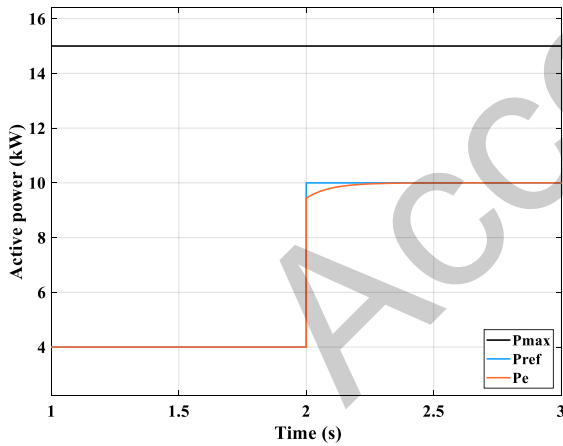

Fig. 7. Maximum transferable, reference, and output active power of the grid-connected VSC with a step change in the active power reference at $t = 2$ s.

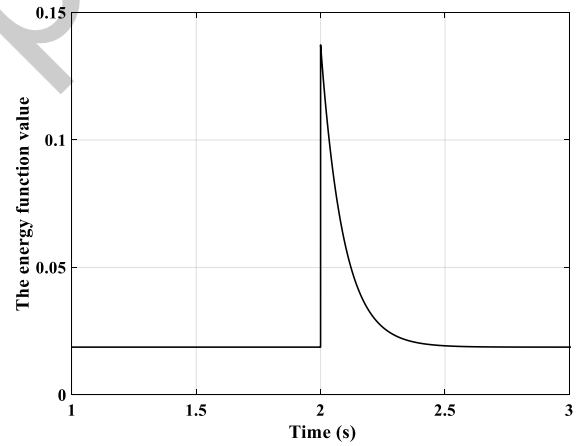

Fig. 8. The energy function value of the grid-connected VSC when the active power reference is changed at $t = 2$ s.

the output active power are illustrated in Fig. 7. The grid impedance is considered to be 10 mH, and the short circuit ratio (SCR) is equal to 5.09 p.u.

The energy function has a positive value as it is shown in Fig. 8. In $t = 2$ s, the energy of the system increases instantly. Then, after a transient, its value decreases to its initial point as the velocity of voltage phase angle and the VSC's inertia are considered to stay constant. The derivative of the energy function with respect to the time in the transient period is negative. This can be seen from Fig. 8. This proves that the energy function will decrease to a certain value, and the system stays stable.

B. Scenario 2: Changing system configuration by increasing the grid impedance (weak grid scenario)

This scenario is related to the VSC connected to a weak grid. The grid impedance is increased to twice compared to the first scenario, 20 mH. In this manner, the SCR is equal to 2.54 p.u. This can happen when there are two equal lines with the impedance equals to 20 mH used in parallel to connect the VSC to the grid and suddenly one of them is disconnected from the system. Considering (1), the maximum value of the active power and the output active power decrease instantaneously, which is also shown in Fig. 9. Then, the output active power increases to reach the reference active power regarding to by using the active power control loop. This also makes an increase in the phase angle of the output voltage. As a first order system, which will stay stable for all positive value of the control gains, the energy function and its derivative with respect to the time shown in Fig. 10 are positive and

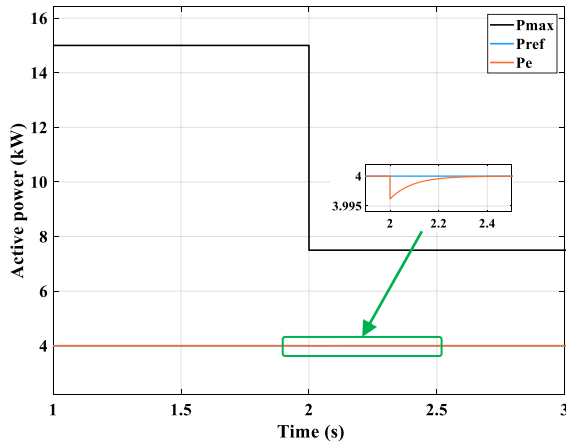

Fig. 9. Maximum transferable, reference, and output active power of the grid-connected VSC with a step change in L_g from 10 mH to 20 mH.

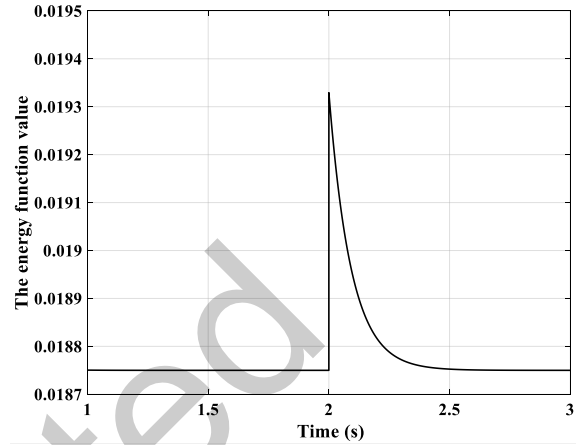

Fig. 10. The energy function value of the grid-connected VSC when the active power reference when in L_g is changed from 10 mH to 20 mH.

negative, respectively.

C. Scenario 3: Finding the marginal point of stability (very weak grid scenario)

In this case the value of grid impedance becomes larger, the output active power decreases more constantly. This makes the phase angle to become larger in order to compensate the loss of active power. Therefore, the kinetic energy released during the transient period becomes larger, and the raise in the energy function becomes larger too. This is shown in Fig. 11. Comparing Fig. 10 and 11, the increasing in the energy function is larger when the grid is weaker where L_g is increased from 10 mH to 37.5 mH. This means that the SCR decreases from 5.09 p.u. to 1.36 p.u. In this circumstance, the system works in a weak-grid condition. Although both cases are stable, if a second order control system is used, the kinetic energy released during the transient time should be absorbed after that. Therefore, there is a better chance for the system with more kinetic energy released during the transient period to become unstable.

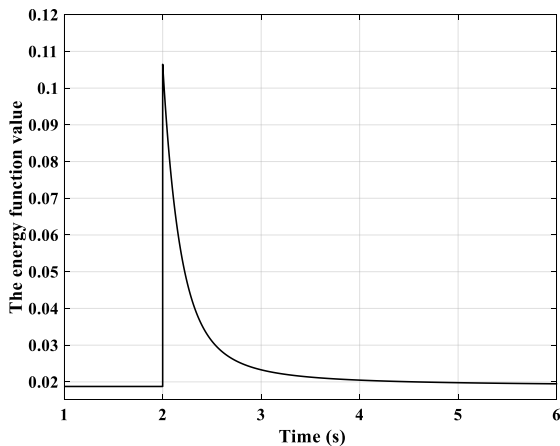

Fig. 11. Maximum transferable, reference, and output active power of the grid-connected VSC with a step change in L_g from 10 mH to 37.5 mH.

As the maximum active power becomes less than the real output active power, then it is assumed that the system does not have an equilibrium point for operation. Although this is not a

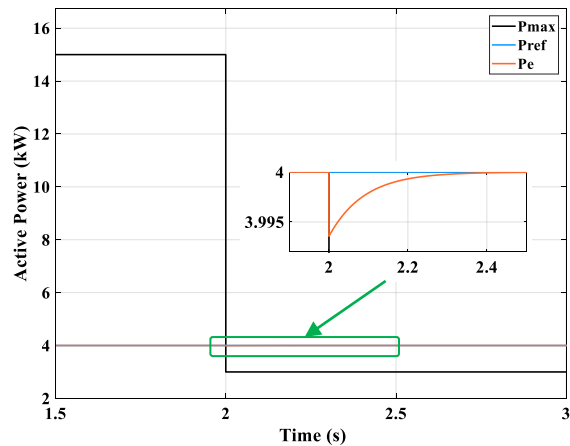

Fig. 12. Maximum transferable, reference, and output active power of the grid-connected VSC with a step change in L_g from 10 mH to 50 mH.

practical case study, it can show that the behavior of the energy function and its derivative with respect to the time in the marginal point of stability. In Fig. 12, the value of the grid impedance increases to a large value, so the value of the maximum active power becomes less than the actual output active power. In this condition, the SCR is equal to 1.02 p.u., which is related to a very weak grid condition. Therefore, there is no equilibrium point in this case. The value of the energy function stands constant. The reason is that its derivative with respect to the time becomes zero at this point. This means that the system cannot recover to its base energy value in the case that the energy function increases. It is not possible to have a positive derivative of the energy function with respect to the time with this control system.

5. Conclusions

In this paper, an energy function of the grid-connected VSC using an active power loop is developed. The energy function is defined based on the swing equation of the system. The concept of the stability of the synchronous machine connected to the infinite bus is used in order to find the energy function. It is shown that the system works in its stable mode with positive value of the energy function, while its derivative with respect to the time is negative. In addition, if there is no equilibrium point for the system to work on, then energy function derivative with respect to the time become zero. In addition, the weak grid's effects on the system's stability is studied. The weak grid is introduced as its SCR value, hence a general comprehension of the weak grid's modeling is presented.

More detailed models including the PLL and the time delay are needed in order to really evaluate the large signal stability of the grid-connected VSC by using the energy function.

References

- [1] S. Nandi, H. A. Toliyat, and X. Li, "Condition Monitoring and Fault Diagnosis of Electrical Motors—A Review," *IEEE Trans. Energy Convers.*, vol. 20, no. 4, pp. 719–729, Dec. 2005.
- [2] M. G. Taul, X. Wang, P. Davari, and F. Blaabjerg, "Grid Synchronization of Wind Turbines during Severe Symmetrical Faults with Phase Jumps," in *2018 IEEE Energy Conversion Congress and Exposition (ECCE)*, Portland, OR, USA, 2018, pp. 38–45.
- [3] S. M. Blair, C. D. Booth, G. M. Burt, and C. G. Bright, "Application of Multiple Resistive Superconducting Fault-Current Limiters for Fast Fault Detection in Highly Interconnected Distribution Systems," *IEEE Trans. Power Deliv.*, vol. 28, no. 2, pp. 1120–1127, Apr. 2013.

- [4] M. J. Duran, I. Gonzalez-Prieto, N. Rios-Garcia, and F. Barrero, "A Simple, Fast, and Robust Open-Phase Fault Detection Technique for Six-Phase Induction Motor Drives," *IEEE Trans. Power Electron.*, vol. 33, no. 1, pp. 547–557, Jan. 2018.
- [5] M. Ashouri, F. Faria da Silva, and C. Leth Bak, "A Harmonic Based Pilot Protection Scheme for VSC-MTDC Grids with PWM Converters," *Energies*, vol. 12, no. 6, p. 1010, Mar. 2019.
- [6] M. Ashouri, F. F. D. Silva, and C. L. Bak, "Application of short-time Fourier transform for harmonic-based protection of meshed VSC-MTDC grids," *J. Eng.*, Oct. 2018.
- [7] P. M. Anderson, "Reliability Modeling of Protective Systems," *IEEE Trans. Power Appar. Syst.*, vol. PAS-103, no. 8, pp. 2207–2214, Aug. 1984.
- [8] F. Blaabjerg, R. Teodorescu, M. Liserre, and A. V. Timbus, "Overview of Control and Grid Synchronization for Distributed Power Generation Systems," *IEEE Trans. Ind. Electron.*, vol. 53, no. 5, pp. 1398–1409, Oct. 2006.
- [9] H.-J. Kim, S.-W. Kang, G.-S. Seo, P. Jang, and B.-H. Cho, "Large-Signal Stability Analysis of DC Power System With Shunt Active Damper," *IEEE Trans. Ind. Electron.*, vol. 63, no. 10, pp. 6270–6280, Oct. 2016.
- [10] H. Li, F. Ren, J. Shang, B. Zhang, J. Lu, and H. Qi, "A novel large-signal stability analysis approach based on semi-tensor product of matrices with Lyapunov stability theorem for DC-DC converters," in *2016 IEEE Energy Conversion Congress and Exposition (ECCE)*, Milwaukee, WI, USA, 2016, pp. 1–5.
- [11] B. Shakerighadi, E. Ebrahimzadeh, F. Blaabjerg, and C. Leth Bak, "Large-Signal Stability Modeling for the Grid-Connected VSC Based on the Lyapunov Method," *Energies*, vol. 11, no. 10, p. 2533, Sep. 2018.
- [12] M. Kabalan, P. Singh, and D. Niebur, "Large Signal Lyapunov-Based Stability Studies in Microgrids: A Review," *IEEE Trans. Smart Grid*, vol. 8, no. 5, pp. 2287–2295, Sep. 2017.
- [13] "Definition and Classification of Power System Stability IEEE/CIGRE Joint Task Force on Stability Terms and Definitions," *IEEE Trans. Power Syst.*, vol. 19, no. 3, pp. 1387–1401, Aug. 2004.
- [14] Z. Tang, D. J. Hill, T. Liu, and H. Ma, "Hierarchical Voltage Control of Weak Subtransmission Networks With High Penetration of Wind Power," *IEEE Trans. Power Syst.*, vol. 33, no. 1, pp. 187–197, Jan. 2018.
- [15] M. Edrah, K. L. Lo, and O. Anaya-Lara, "Impacts of High Penetration of DFIG Wind Turbines on Rotor Angle Stability of Power Systems," *IEEE Trans. Sustain. Energy*, vol. 6, no. 3, pp. 759–766, Jul. 2015.
- [16] P. Kundur, N. J. Balu, and M. G. Lauby, *Power system stability and control*. New York: McGraw-Hill, 1994.
- [17] K. Ogata, *Modern control engineering*, 5th ed. Boston: Prentice-Hall, 2010.
- [18] H. Wu and X. Wang, "Transient Stability Impact of the Phase-Locked Loop on Grid-Connected Voltage Source Converters," in *2018 International Power Electronics Conference (IPEC-Niigata 2018 -ECCE Asia)*, Niigata, 2018, pp. 2673–2680.
- [19] B. Shakerighadi, E. Ebrahimzadeh, F. Blaabjerg, and C. L. Bak, "Lyapunov- and Eigenvalue-based Stability Assessment of the Grid-connected Voltage Source Converter," in *2018 IEEE International Power Electronics and Application Conference and Exposition (PEAC)*, Shenzhen, 2018, pp. 1–6.
- [20] P. Hart and B. Lesieutre, "Energy function for a grid-tied, droop-controlled inverter," in *Proc. North American Power Symposium (NAPS)*, 2014, pp. 1–6.

BIBLIOGRAPHY



Bahram Shakerighadi (SM' 17) received the B.Sc. degree from University of Mazandaran, Iran, in 2010 and the M.Sc. degree from University of Tehran, Iran, in 2014. He is currently working toward the Ph.D. degree in Department of Energy Technology, Aalborg University, Denmark. His current research interests include stability of Power Electronic-based power systems and control of voltage source converters.



Esmail Ebrahimzadeh (S'16) received the M.Sc. degree in Electrical Engineering from University of Tehran, Tehran, Iran, where he has also been a lecturer for undergraduate courses. In 2015, he was employed as a PhD Fellow at the Department of Energy Technology, Aalborg University, Aalborg, Denmark. He has been a visiting R&D Engineer at Vestas Wind Systems A/S, Aarhus, Denmark, in 2017, where he is currently working as a R&D Control Engineer. His research interests include modelling, design, and control of power-electronic converters in different applications, as well as power quality and stability analysis in large wind power plants. He is an IEEE member and received the best paper awards at IEEE PEDG 2016 and IEEE PES GM 2017.



Claus Leth Bak was born in Århus, Denmark, on April 13th, 1965. He received the B.Sc. with honors in Electrical Power Engineering in 1992 and the M.Sc. in Electrical Power Engineering at the Department of Energy Technology at Aalborg University in 1994. After his studies he worked as a professional engineer with Electric Power Transmission and Substations with specializations within the area of Power System Protection at the NV Net Transmission System Operator. In 1999 he was employed as an Assistant Professor at the Department of Energy Technology, Aalborg University, where he holds a Full Professor position today. He received the PhD degree in 2015 with the thesis "EHV/HV underground cables in the transmission system". He has supervised/co-supervised +35 PhD's and +50 MSc theses. His main Research areas include Corona Phenomena on Overhead Lines, Composite Transmission Towers, Power System Modeling and Transient Simulations, Underground Cable transmission, Power System Harmonics, Power System Protection and HVDC-VSC Offshore Transmission Networks. He is the author/coauthor of app. 290 publications. He is a member of Cigré SC C4 AG1 and SC B5 and chairman of the Danish Cigré National Committee. He is an IEEE senior member (M'1999, SM'2007). He received the DPSP 2014 best paper award and the PEDG 2016 best paper award. He serves as Head of the Energy Technology PhD program (+ 100 PhD's) and as Head of the Section of Electric Power Systems and High Voltage and is a member of the PhD board at the Faculty of Engineering and Science.



Frede Blaabjerg received the Ph.D. degree in electrical engineering from Aalborg University in 1995. He was with ABB-Scandia, Randers, Denmark, from 1987 to 1988. He became an Assistant Professor with Aalborg University in 1992, an Associate Professor in 1996, and a Full Professor of power electronics and drives in 1998, where he became a Villum Investigator in 2017. He is currently a Full Professor and a *honoris causa* at University Politehnica Timisoara (UPT), Romania and Tallinn Technical University (TTU) in Estonia. His current research interests include power electronics and its applications, such as in wind turbines, PV systems, reliability, harmonics, and adjustable speed drives. He has published over 500 journal papers in the fields of power electronics and its applications. He has co-authored two monographs and edited seven books in power electronics and its applications. Dr. Blaabjerg has been the President Elect of the IEEE Power Electronics Society since 2018. He has received 26 IEEE Prize Paper Awards, the IEEE PELS Distinguished Service Award in 2009, the EPE-PEMC Council Award in 2010, the IEEE William E. Newell Power Electronics Award 2014, and the Villum Kann Rasmussen Research Award in 2014. He was the Editor-in-Chief of the IEEE Transactions on Power Electronics from 2006 to 2012. He was a Distinguished Lecturer for the IEEE Power Electronics Society from 2005 to 2007 and the IEEE Industry Applications Society from 2010 to 2011, and from 2017 to 2018. Dr. Blaabjerg was nominated in 2014, 2015, 2016, and 2017 by Thomson Reuters to be between the most 250 cited researchers in Engineering in the world.

Accepted