



AALBORG UNIVERSITY
DENMARK

Aalborg Universitet

Real-time Monitoring of Low Voltage Grids using Adaptive Smart Meter Data Collection

Kemal, Mohammed Seifu

Publication date:
2019

Document Version
Publisher's PDF, also known as Version of record

[Link to publication from Aalborg University](#)

Citation for published version (APA):

Kemal, M. S. (2019). *Real-time Monitoring of Low Voltage Grids using Adaptive Smart Meter Data Collection*. Aalborg Universitetsforlag. Ph.d.-serien for Det Tekniske Fakultet for IT og Design, Aalborg Universitet

General rights

Copyright and moral rights for the publications made accessible in the public portal are retained by the authors and/or other copyright owners and it is a condition of accessing publications that users recognise and abide by the legal requirements associated with these rights.

- ? Users may download and print one copy of any publication from the public portal for the purpose of private study or research.
- ? You may not further distribute the material or use it for any profit-making activity or commercial gain
- ? You may freely distribute the URL identifying the publication in the public portal ?

Take down policy

If you believe that this document breaches copyright please contact us at vbn@aub.aau.dk providing details, and we will remove access to the work immediately and investigate your claim.

**REAL-TIME MONITORING OF LOW
VOLTAGE GRIDS USING ADAPTIVE
SMART METER DATA COLLECTION**

**BY
MOHAMMED SEIFU KEMAL**

DISSERTATION SUBMITTED 2019



AALBORG UNIVERSITY
DENMARK

Real-time Monitoring of Low Voltage Grids using Adaptive Smart Meter Data Collection

Ph.D. Dissertation
Mohammed Seifu Kemal

Aalborg University
Department of Electronic Systems
Fredrik Bajers Vej 7B
DK-9220 Aalborg

Dissertation submitted: April 2019

PhD supervisors: Associate Professor Rasmus Løvenstein Olsen
Aalborg University

Professor Hans-Peter Schwefel
Aalborg University

PhD committee: Associate Professor Jimmy Jessen Nielsen (chairman)
Aalborg University

Professor Andrea Bondavalli
University of Florence

Associate Professor Rune Hylsberg Jacobsen
Aarhus University

PhD Series: Technical Faculty of IT and Design, Aalborg University

Institut: Department of Electronic Systems

ISSN (online): 2446-1628
ISBN (online): 978-87-7210-433-1

Published by:
Aalborg University Press
Langagervej 2
DK – 9220 Aalborg Ø
Phone: +45 99407140
aauf@forlag.aau.dk
forlag.aau.dk

© Copyright: Mohammed Seifu Kemal

Printed in Denmark by Rosendahls, 2019

Dedicated to my late father, Seifu Kemal who instilled in me the value of learning at a young age and to my loving mother, Sekina Awel for the immense encouragement and inspiration in my life!

Abstract

Modern-day electric distribution grid is experiencing rapid and fundamental changes. The share of distributed generation units such as small-scale wind turbines, photovoltaic panels, electric vehicle charging stations and heat pumps is growing at low voltage distribution grids. The increase in the integration of renewable units transforms the traditional centralised uni-directional chain of energy production, to a distributed bidirectional power flow. This ongoing transition is challenging the Distribution System Operators as they can no longer rely on traditional methods to ensure reliable operation of the distribution grid. The first step towards the reliable operation of Low Voltage (LV) grids is to increase observability via real-time monitoring and enable data-driven novel applications such as Distribution System State Estimation, Demand Management, and Voltage Control.

Countries in Europe such as Denmark have close to 100% roll-out of Advanced Smart Metering Infrastructure (AMI) at the LV distribution grids. But the current AMI is developed and mainly used for billing of customer power consumption with a meter reading at long update rates (6 hours to once or twice a day). The low bandwidth AMI communication networks contribute to the slow updates of smart meter data and high latency that influences data quality for real-time LV monitoring applications. Data from smart meters should be collected in a resilient, secure and timely manner to fulfil requirements for real-time applications.

This thesis investigates the use of smart meter data in the context of real-time monitoring applications. The three main contributions of the thesis are **1)** Design and analysis of adaptive data collection mechanisms to support near real-time monitoring applications using AMI data **2)** Assessment of real-time LV grid applications such as Distribution System State Estimation, Demand Management, and Attack Detection in Voltage Control **3)** Extension and coupling of evaluation frameworks to create a co-domain simulation framework incorporating AMI, electrical grid and communication subsystems.

The proposed adaptive data collection mechanisms strive to facilitate near real-time data flow by utilising the existing AMI. The thesis introduces the so-called mismatch probability, as an information quality metric. This metric is useful to capture the com-

bined impact of delays, information dynamics and access to the information. Scheduling of smart meter data access that optimises information quality based on mismatch probability is proposed and assessed in the thesis.

Secondly, assessment of LV grid applications based on smart meter data is presented focusing on Demand Management framework, Distribution Systems State Estimation, and Voltage Control. The evaluations add insight in understanding the integrated system behaviour to various realistic conditions such as imperfect communication links, slow smart meter updates and cyber attacks.

Finally, the high complexity of designing and evaluating the systems mentioned above requires advanced design and testing methods. The thesis presents extension and coupling of evaluation frameworks ranging from event-based simulation tools to real-time co-domain simulation framework.

The work has been performed mainly under the framework of the Danish research project REMOTEGRID (REliable MOniToring and Estimation of distribution GRID for smart societies) and partly under European SmartC2Net and Net2DG projects.

Resumé

Det elektriske distributionsnetværk gennemgår i disse tider hurtige og fundamentale ændringer. Andelen af distribuerede strømgenererende enheder, såsom små husstandsvindmøller, solceller, ladestationer til el-biler og varmepumper, stiger i lavspændingsnetværket. Den øgede integration af vedvarende enheder transformerer den traditionelle og centraliserede produktion af energi fra et uni-direktionelt til et bi-direktionelt flow. Den igangværende transition udfordrer operatørerne af distributionsnetværkerne, da de ikke længere kan anvende traditionelle metoder til at sikre pålidelig drift af disse netværk. Det første skridt mod en pålidelig drift af lavspændingsnetværk, er at øge evnen til at kunne observere netværket via realtidsovervågning, der muliggør datadrevne applikationer såsom distribueret estimering af distributionsnetværkets systemtilstand, monitorering af energi og effektforbrug, samt regulering af forbrug og produktion. Europæiske lande såsom Danmark har næsten 100% udrulning af avanceret smart-måler infrastruktur (AMI) i lavspændingsnetværket. Den nuværende AMI er primært udviklet og brugt til at afregne kunders strømforbrug ved afmåling med lange opdateringer af tidsintervaller (fra 6 timer til en til to gange om dagen). Den lave båndbredde i AMI kommunikationsnetværk resulterer i sjældne data-opdateringer og meget høj latenstid, hvilket påvirker kvaliteten af den data, som er tilgængelig for realtids-applikationer. Data fra smart-målere bør indsamles på en modstandsdygtig, pålidelig, sikker og rettidig manér for at opfylde kravene fra realtids-applikationer.

Denne afhandling undersøger brugen af smart-målere i forbindelse med applikationer til realtidsovervågning. De tre hovedbidrag i denne afhandling er 1) Design og analyse af tilpassende dataindsamlingsmekanismer, der understøtter applikationer til nær-realtidsovervågning ved brug af AMI data 2) Vurdering af realtidsapplikationer til lavspændingsnetværket såsom distribueret systemtilstands-estimering, regulering og håndtering af energi og effektforbrug, og produktion samt detektering af cyber-angreb i spændingsreguleringsscenarier 3) Udvidelse og sammenlægning af flere evalueringsværktøjer, der sammenfatter AMI, el-netværk og kommunikationsdelsystemer i et ko-domæne simuleringsrammeverk.

De foreslåede tilpassede strategier søger at fremme de nære realtids-datastrømme ved at anvende det eksisterende AMI. Afhandlingen introducerer en parameter for informa-

tionskvalitet kaldet mismatch probability. Denne måleenhed kombinerer påvirkningen af rettidige forsinkelser, informationsdynamik og adgangsteknik til information i en metrik. Planlægning af smart-måler data tilgange, der optimerer informationskvaliteten baseret på mismatch probability, er foreslået og vurderet i afhandlingen.

Dernæst præsenteres en vurdering af lavspændingsnetværkets applikationer baseret på smart-måler data, og med fokus på energi- og effektreguleringsrammeværk, distribueret systemtilstands estimering og effekt regulering. Evalueringerne giver indsigt i, hvordan det integrerede system opfører sig under forskellige realistiske forhold, såsom fejlbehæftede kommunikationskanaler, langsomme smart-måler opdateringer og cyberangreb. Den høje kompleksitet i design og evaluering af de ovennævnte systemer, kræver avancerede design- og testmetoder. Denne afhandling præsenterer udvidelse og sammenlægning af evalueringsrammer rangerende fra hændelsesbaserede simuleringstværværker til realtids ko-domæne simulering rammeværker. Arbejdet er primært udført under rammerne i det danske forskningsprojekt REMOTEGRID (REliable MOniToring and Estimation of distribution GRID for smart societies), og delvist under European SmartC2Net og Net2DG projekter.

Contents

Abstract	iii
Resumé	v
Thesis Details	xiii
Acknowledgements	xv
Acronyms	xvii
I Summary of Contributions	1
1 Introduction	3
1.1 Motivation	3
1.2 Challenges for Real-time Monitoring of LV-grids	6
1.3 Adaptive Data Collection in Context of Real-time Monitoring of LV-grids	7
1.4 Problem Statement	8
1.5 Summary of Contributions	9
2 Background	13
2.1 Collaborative Projects	13
2.1.1 REMOTEGRID Project	13
2.1.2 SmartC2Net Project	15
2.1.3 Net2DG Project	15
2.2 Evolution of AMI Infrastructure	15
2.2.1 History of Electricity Measurement	16
2.2.2 Evolution of Electricity Meters	16
2.3 Advanced Metering Infrastructure Architecture	18
2.3.1 Metering Data Access	18

2.3.2	Metering Reading Cycle	19
2.3.3	Metering Infrastructure Characterization	20
2.3.4	Communication Technologies in Advanced Metering Infrastructure	20
2.4	Information Quality Metrics	21
3	Co-domain Simulation for Evaluation of Low Voltage Grids	23
3.1	Introduction	23
3.2	Simulation Framework	24
3.2.1	Simulation of Proactive Smart Meter Data Access	24
3.2.2	Simulation of Reactive Smart Meter Data Access	26
3.2.3	Cyber Attack Models for Voltage Control in Low Voltage Grids	28
3.3	Contribution to Real-time HIL Testbed	28
3.3.1	Background on Real-time HIL Testbed	28
3.3.2	Contribution to Network Emulation Platform	30
3.3.3	Contribution to Integration of Use Cases	31
3.4	Active Power Management Use Case	32
3.5	Summary	33
4	Monitoring of LV Grid Using AMI Data	35
4.1	Introduction	35
4.2	Information Quality Metric for Adaptive Data Collection	36
4.3	Adaptation of Smart Meter Update Rates for Proactive Data Access	36
4.3.1	Assessment of Static Delay Scenario	36
4.3.2	Impact of Load-dependent Delays	38
4.4	Adaptive Scheduling of SM Data Using Reactive Data Access	39
4.4.1	Analysis of Dynamicity of Smart Meter Measurements	39
4.4.2	Analysis of Scheduling Impact on Information Quality	40
4.5	Heuristic Scheduling Algorithm for Improved Information Quality	41
4.5.1	Parametric Analysis	42
4.6	Towards On-line Scheduling Optimization	42
4.7	Summary	44
5	Assessment of LV Grid Applications	45
5.1	Introduction	45
5.2	Assessment of Distributed Systems State Estimation	46
5.2.1	Embedding Periodical Data Collection in Smart Meter Reading Cycles	46
5.2.2	Trade-off Between Timeliness and Accuracy	47
5.3	Assessment of Demand Management Application	51
5.3.1	System Description	52
5.3.2	Verification Tests	53
5.4	Assessment of Detection of Cyberattacks for LV Control Application	55

Contents	ix
5.4.1 System Description	55
5.4.2 Adversary Model and Attack Scenarios	56
5.4.3 Evaluation	57
5.5 Summary	58
6 Conclusion and Outlook	59
References	63
II Publications	69
A A Real-Time Open Access Platform Towards Proof of Concept for Smart Grid Applications	71
A.1 Introduction	73
A.2 Smart Energy Systems Laboratory Architecture	75
A.2.1 Electrical GRID	75
A.2.2 DiSC-OPAL Toolbox	79
A.2.3 ICT and Network Emulation	80
A.2.4 Control Layer	82
A.3 Real Time Test Cases	83
A.3.1 Active Power Management in Distribution Grid Test Case	83
A.3.2 Demand Management Platform	84
A.4 Conclusion	92
References	92
B On-line Configuration of Network Emulator for Intelligent Energy System Testbed Applications	95
B.1 Introduction	97
B.2 Related Works	98
B.3 Smart Energy Systems Laboratory	98
B.3.1 Communication Layer	98
B.3.2 Control Layers	100
B.3.3 Power System Assets	100
B.3.4 Online Configuration of Network Emulator Overview	100
B.4 System Model	101
B.4.1 Visualization Interface	101
B.4.2 Kaunet Configuration	102
B.4.3 Network Sockets	104
B.4.4 Network Emulation Configuration	104
B.5 Conclusion	105
References	105

C	Information Quality Aware Data Collection for Adaptive Monitoring of Distribution Grids	107
C.1	Introduction	109
C.2	Adaptation Functionalities	110
C.3	Analysis of Two Level Smart Meter Data Access Infrastructure	111
C.3.1	System Description	111
C.3.2	Simulation Model and Metrics	112
C.3.3	Quantitative Analysis of Smart Meter Update Rates Over Static Delay Model	113
C.3.4	Quantitative Analysis of Smart Meter Update Rates Over Update Rate Dependent Delay Model	116
C.4	Summary and Outlook	117
	References	117
D	Optimized Scheduling of Smart Meter Data Access: A Parametric Study	121
D.1	Introduction	123
D.2	Related Work	125
D.3	System Description	126
D.3.1	Information Quality Metrics	127
D.4	Parametric Study	128
D.4.1	Smart Meter Scheduling Parameters	128
D.4.2	Low-Voltage Grid Scenarios	129
D.5	Optimized Data Access Scheduling Algorithm	132
D.6	Conclusion	135
	References	136
E	On the Trade-off Between Timeliness and Accuracy for Low Voltage Distribution System Grid Monitoring Utilizing Smart Meter Data	139
E.1	Introduction	141
E.2	Towards Near Real Time Monitoring of LV Grid Using Smart Meter Data	145
E.2.1	Requirements for Monitoring Systems in Active LV Grids	145
E.2.2	AMI Data Access Constraints	146
E.2.3	Conceptual Approach for Near Real-time SM Data Access for LV DSSE	147
E.3	On the Trade-off Between Timeliness and DSSE Accuracy	149
E.3.1	Weighted Least Squared State Estimation	149
E.3.2	Evaluation Metrics	151
E.3.3	LV Grid Scenario	152
E.3.4	AMI Scenario	153
E.3.5	Impact of Size of Selected Smart Meters on Timeliness	154

E.3.6	Analysis of Trade-off Between DSSE Accuracy and Timeliness	155
E.4	Conclusion and Outlook	159
	References	160
F	Model-Free Detection of Cyberattacks on Voltage Control in Distribution Grids	165
F.1	Introduction	167
F.2	Background	168
F.2.1	Low-Voltage Distribution Grids	168
F.2.2	Related Work	169
F.3	System Description	170
F.4	Adversary Model and Attack Scenarios	171
F.5	Attack Detection Methodology	174
F.6	Evaluation	175
F.6.1	Experimental Setup	176
F.6.2	The DoS Attack Experiment	176
F.6.3	The Replay Attack Experiment	176
F.6.4	The Integrity Attack Experiment	177
F.6.5	Discussion	177
F.7	Conclusion	181
	References	181
G	Distributed flexibility management targeting energy cost and total power limitations in electricity distribution grids	185

Thesis Details

Thesis Title: Real-time Monitoring of Low Voltage Grids using Adaptive Smart Meter Data Collection
Ph.D. Student: Mohammed Seifu Kemal
Supervisors: Assoc. Prof. Dr. Rasmus Løvenstein Olsen, Aalborg University
Prof. Dr. Hans-Peter Christian Schwefel, Aalborg University

The main body of this thesis consist of the following papers.

- [A] Kemal, Mohammed Seifu; Petersen, Lennart; Iov, Florin; Olsen, Rasmus Løvenstein, “A Real-Time Open Access Platform Towards Proof of Concept for Smart Grid Applications.,” *Journal of Communication, Navigation, Sensing and Services*, Vol. 2017, No. 1, 3, p. 49-74, 19.02.2018.
- [B] Kemal, Mohammed Seifu; Iov, Florin; Olsen, Rasmus Løvenstein; Kristensen, Thomas le Fevre; Apostolopoulos, Christos, “On-line Configuration of Network Emulator for Intelligent Energy System Testbed Applications,” *IEEE AFRICON 2015*, IEEE Press, 2015.
- [C] Kemal, Mohammed Seifu; Olsen, Rasmus Løvenstein; Schwefel, Hans-Peter, “Information Quality Aware Data Collection for Adaptive Monitoring of Distribution Grids,” *SGIoT: The 1st EAI International Conference on Smart Grid Assisted Internet of Things*, EAI - European Alliance for Innovation, 2017.
- [D] Kemal, Mohammed Seifu; Olsen, Rasmus Løvenstein; Schwefel, Hans-Peter, “Optimized Scheduling of Smart Meter Data Access: A Parametric Study,” *2018 IEEE International Conference on Communications, Control, and Computing Technologies for Smart Grids (SmartGridComm)*, IEEE, 2018.
- [E] Kemal, Mohammed Seifu; Martin-Loeches, Ruben Sánchez, Iov, Florin; Olsen, Rasmus Løvenstein and Schwefel, Hans-Peter, “On the trade-off between timeliness and accuracy for low voltage distribution system grid monitoring utilizing smart meter data,” *Submitted to: IEEE Transactions on Industrial Informatics journal*, ISSN: 1551-3203, 2019.

- [F] Kemal, Mohammed Seifu; Aoudi, Wissam; Olsen, Rasmus; Almgren, Magnus, “Model-Free Detection of Cyberattacks on Voltage Control in Distribution Grids,” *Submitted to: European Dependability Computing Conference, EDCC 2019.*
- [G] Bessler, Sanford; Kemal, Mohammed Seifu; Silva, Nuno ; Olsen, Rasmus Løvenstein; Iov, Florin; Drenjanac, Domagoj; Schwefel, Hans-Peter, “Distributed Flexibility Management Targeting Energy Cost and Total Power Limitations in Electricity Distribution Grids,” *Sustainable Energy, Grids and Networks*, Vol. 14, p. 35-46 , 01.06.2018.

This thesis has been submitted for assessment in partial fulfilment of the PhD degree. The thesis is based on the submitted or published scientific papers which are listed above. Parts of the papers are used directly or indirectly in the extended summary of the thesis. As part of the assessment, co-author statements have been made available to the assessment committee and are also available at the Faculty. The attached papers have been reformatted to fit the format of this dissertation, but is otherwise left unedited since publication.

Acknowledgements

First, I would like to express my sincere gratitude to my supervisors Assoc. Prof. Dr. Rasmus Løvenstein Olsen and Prof. Dr. Hans-Peter Christian Schwefel for the continuous support of my Ph.D. study and related research, for their patience, motivation, and immense knowledge. Their guidance helped me in all the time of research and writing of this thesis. I could not have imagined having a better advisor and mentor for my Ph.D. study.

This journey would not have been possible without the support of my family and friends. To my big family in Addis Ababa, thank you for encouraging me in all of my pursuits and inspiring me to follow my dreams. I also owe special gratitude to my family in Copenhagen, The Hissabus, who has provided me through moral and emotional support. Especially my fiancé, Semira Hissabu for her great love and support, though I was working late nights and weekends on our first year of moving in together.

Further, I would like to express my gratitude to my colleagues at the Wireless Communication Networks section for a friendly and enjoyable work environment. Thank you Kamal Shahid for sharing the journey as my office mate, for all the fun and helpful discussions. Thank you Dorthé Sparre and Linda Villadsen for your cooperation in all matters.

Also, I thank my fellow lab-mates at Smart Energy Systems Laboratory, Department of Energy and Technology, most notably Assoc. Prof. Dr. Florin Iov for his valuable guidance and coordination of the experimental works in the lab, Lennart Petersen and Ruben Sanchez with whom I collaborated and learned a lot from. I must thank Magnus Almgren and Wissam Aoudi of Chalmers University of Technology, Department of Computer Science and Networks in Gothenburg Sweden where I spent three months as a visiting researcher. Many thanks for providing supportive and lively working environment and continued collaboration afterwards.

Finally, My sincere thanks goes to fellow members of the RemoteGRID, SmartC2Net and Net2DG projects for the stimulating discussions and collaborations throughout my Ph.D. Many thanks for all your encouragement!

Mohammed Seifu Kemal
Aalborg University, April 30, 2019

Acronyms

ADCM Adaptive Data Dollection Mechanism.

AMI Advanced Smart Metering Infrastructure.

AMI-DAS AMI Data Access System.

AMR Automated Meter Reading.

CEMS Customer Energy Management System.

DC Data Concentrator.

DM Demand Management.

DSO Distribution System Operators.

DSSE Distribution System State Estimation.

HES Head End Systems.

HIL Hardware-in-the-Loop.

LV Low Voltage.

LVGC Low Voltage Grid Controller.

mmPr Mismatch Probability.

MVGC Medium Voltage Grid Controller.

Net2DG Leveraging Networked Data for the Digital Electricity Grid.

ODAS Optimized Scheduling of Smart Meter Data Access Algorithm.

PLC Power Line Communication.

PV Photovoltaic.

QoS Quality of Service.

REMOTEGRID REliable MOniToring and Estimation of distribution GRID for smart societies.

RES Renewable and Sustainable Energy Sources.

RF Radio Frequency.

SES Smart Energy Systems.

SM Smart Meter.

SmartC2Net Smart Control of Energy Distribution Grids over Heterogeneous Communication Networks.

VC Voltage Control.

Part I

Summary of Contributions

Chapter 1

Introduction

1.1 Motivation

In today's world, energy availability is limited due to scarce resources. At the same time, carbon emissions should be decreased. A UN report says carbon emissions must be cut 'significantly' by 2020 [1]. Renewable and Sustainable Energy Sources (RES) help reduce carbon emissions [2]. The increasing penetration of RES has begun to transform the traditional power system. In the past, large power plants at the transmission level supplied power to the entire power system. Nowadays, decentralized generation at the medium and low voltage level has transformed the distribution system from a passive to an active role in the power systems.

The massive integration of grid-connected Photovoltaic (PV) systems and heat pumps based on power electronic converters is adding operational challenges on Danish Distribution System Operators (DSO)s [4]. To illustrate the current challenges faced by the DSO, the evolution of PV capacity in Denmark from 2011 to 2016 is plotted in Fig. [4]. From the plot, the blue line shows that there is a drastic increase in the number of PVs installed in Denmark due to tax deduction between 2012 and 2013 while the red line shows an increase in the amount of energy generated by PVs. The technical challenges faced by the DSOs include sudden voltage dips and swells, unexpected and uncontrollable voltage variations, congestion or bidirectional power flows [2].

Currently, DSOs lack the technologies in LV grids that can ensure fulfillment of operational requirements defined by grid codes and technical standards [7]. For example, the awareness in case of the faulty operating condition depends entirely on customer complaints since abnormal conditions and outages are not automatically reported in the control centers [3]. Furthermore, the origin of the problems are often not identified, and system restoration might last for hours while requiring a significant amount of workforce [3]. The goal of DSOs is to keep LV grid under normal operational conditions, i.e., all the

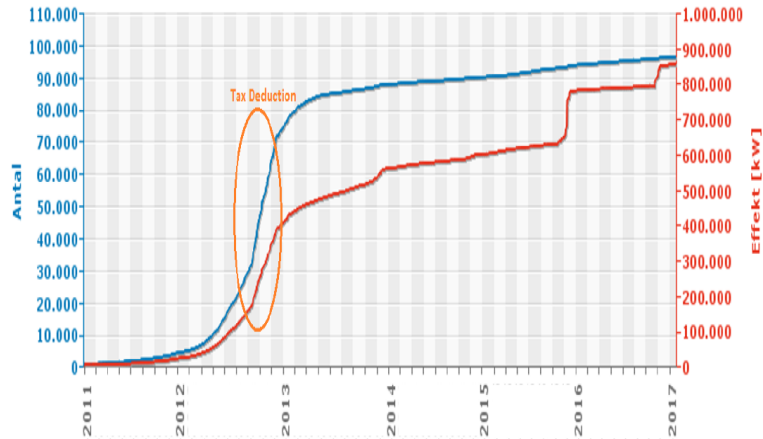

Fig. 1.1: Solar PV capacity growth in Denmark from 2011 to 2016 [4]

loads are supplied without violating any operational constraints [7]. To attain this goal, continuous monitoring of the system is required, referred to as *real-time monitoring of the LV grid* in this thesis.

Real-time monitoring increases grid observability and enables data-driven novel applications such as Distribution System State Estimation, Demand Management, and Voltage Control. In LV grids, the operating conditions can be determined if the grid topology, parameters of lines/cables and complex voltage phasors in every node of the system are known [5]. The DSOs operate the power grid from the control centers and require the acquisition of electrical measurements from measurement devices placed along the distribution grid (smart meters in this thesis). Nevertheless, since there are a sizable amount of customers/prosumers located in LV grid, and thus, a large number of potential measurement points, deploying and maintaining expensive communication technologies such as Fiber, Ethernet and cellular would not be economically feasible for the DSOs. Smart Meter (SM) systems using low bandwidth technologies such as Radio Frequency (RF) Mesh and Power Line Communication (PLC) are widely deployed in existing LV grids in Europe. Therefore, there is a need for a solution that can utilize limited measurements to enable monitoring of LV grids utilizing SM data. The application responsible for overcoming the problem of shortage of measurements by predicting the missing states using historical measurements is referred to as *Distribution System State Estimation (DSSE)*.

An accurate estimate of LV distribution grid open doors to enable data-driven real-time monitoring applications. The focus of this thesis is voltage control and Demand management applications. *Voltage Control (VC)* at DSO control center utilizes voltage

measurements collected from the metering devices to ensure that the LV grid satisfies the grid code by maintaining average operational voltages. *Demand Management (DM)* in the context of this thesis is the function that handles electricity demand dynamically for energy cost minimization and peak shaving.

It is intuitive that enabling such functions requires as a first step a reliable source of information providing knowledge about the operational state of LV grid. Smart meters could be used to provide measurements for monitoring applications since they are massively deployed and measure a lot of signals potentially useful for LV grid observability. A *SM* is defined as an electronic device that measures the consumption of electric energy and with two-way communication between the DSO and households for consumption billing and monitoring. For electrical distribution systems, data from SMs can be employed to monitor and control the condition of the LV-grid. Therefore, it is essential that information from SMs must be gathered in a resilient and timely way satisfying all the communication standards and requirements. Several initiatives have been offered in contemporary years to regulate the communication to and from the SMs. Examples include IEC 62056-62, IEC 62056-58 data exchange for meter reading and load control, communication system for meters and remote reading of meters and standard language for smart devices DLMS/COSEM protocol [9].

Integration of metering in LV grid has been the focus of most recent infrastructure developments. One of the first implementation of automatizing the energy metering system at LV grids, *Automated Meter Reading (AMR)* [10], facilitated remote reading of customer consumption records by DSOs. Due to its one-way communication system, *AMR* has limited capabilities for remote reading and cannot run additional applications such as on-demand SM access, over voltage and over current alarms. The limitations inspired the industry to evolve towards the *AMI*, which provides bidirectional communication between DSO centre and SMs.

Advanced metering infrastructure (AMI) is a system of SMs, communication networks with data management systems that aim to offer the DSOs access to precise data employed for billing, collecting consumer info, and facilitating a two-way communication on the distribution grid [11] (see Fig. 1.2). *AMI* systems comprise software, hardware, communications and displays of user energy, meter data management software, customer-related systems, and supplier business systems [12]. In Denmark, where all homes are about to have smart electric meters by 2020 [13], DSOs can employ *AMI* to provide measurements for real-time monitoring applications. However, to leverage the existing *AMI* for monitoring of distribution grids, there are challenges such as; adapting the current infrastructure (intended mainly for electricity billing with slow update frequency from around 6 hours to once or twice a day) for the collection of real-time data and collecting more data by the constrained *AMI* network.

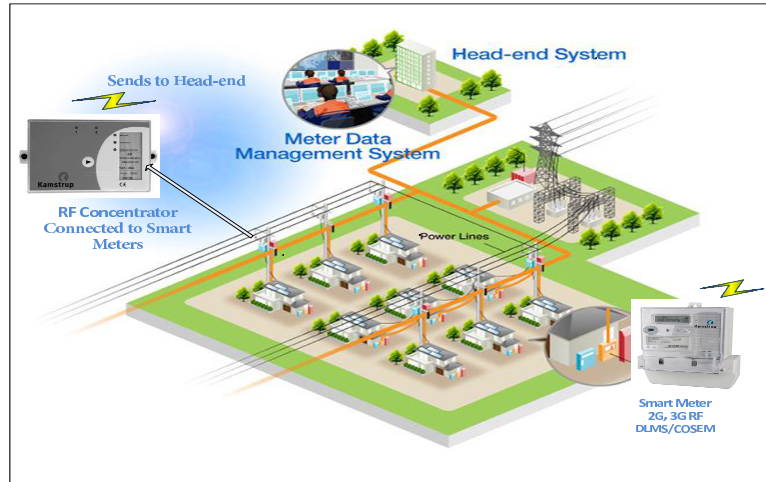

Fig. 1.2: Depiction of an example AMI with wireless 2G/3G smart meters, concentrators and Head-end system for metering data management applications [9]

1.2 Challenges for Real-time Monitoring of LV-grids

Real-time monitoring of LV distribution grids using SM data represents significant challenges mainly because of 1) the increasing integration of RES at LV grid contributing to new electrical behavior which is referred as *grid dynamics* 2) the constrained low bandwidth AMI communication network adding to limited data collection capability which is presented in the thesis as *AMI communication dynamics*.

For LV grids with high integration of RES, the grid is liable to short and unpredictable power and voltage variations. For instance, during partially cloudy conditions, PV generation can fluctuate as fast as within a few seconds, which affects part of the LV grid behavior. Similarly, wind speed variations have the same impact on electrical behavior of LV-grid. The primary challenge for real-time monitoring of LV-grid using SM data presented by dynamic LV grid are:

1. The generation from distributed generation units does not necessarily match with the distribution grid's load demand, i.e., the peak demand in residential areas occurs commonly when there is no or few PV productions [7]. Thus, the distribution system has to be designed to balance load utilizing SM data.
2. The unpredictable production from distributed generation units threatens the legal and physical limits of the distribution grid. It can produce critical voltage variations, notably when the local consumption is surpassed by the local production [7]. The challenge is to provide required SM measurements for reliable voltage

control application.

3. Distributed Generation can contribute to an efficient grid infrastructure, e.g. when production and generation are close to each other in the grid topology and follow similar profiles, a positive impact on grid loss reduction can result. In order to apply such loss minimization approaches, grid monitoring and its coupling to demand and generation management functions is required.
4. Bidirectional power flow challenges the normal operation of existing LV grid, which originally was not designed to operate under such conditions [1]. DSO's need to maintain normal operational conditions. The challenge is to provide the required measurements utilizing SMs for DSSE to assist LV grid management system.

Since there is a large amount of households located in LV grid, and thus, a large number of measurement points, deploying and maintaining traditional wired communication, e.g., Ethernet or Fiber are not economically feasible for AMI operators [15]. Hence, most AMI systems in Europe deploy existing cost-effective low bandwidth communication technologies such as RF mesh networks or PLC and cellular (2G, 3G for geographically remote areas) [14]. The main challenges for supporting near real-time monitoring of LV-grids presented by constrained AMI communication dynamics are:

1. For PLC and RF mesh type networks, small data rate, and imperfect/variable Quality of Service (QoS) properties within the system.
2. If the communication medium is shared with other users (e.g., GSM, 3G, shared PLC), the impact of cross traffic affects the performance of the whole system creating increased delays, packet losses, and low throughput.
3. Data communications and AMI components are influenced by noisy and crowded ISM cellular licensed bands in urban areas.
4. Also, another challenge is of cyber-attacks and security of data. As per reference [17], the growing integration of communication technologies makes LV grids vulnerable to cyber-attacks, which can cause grave damage to the LV infrastructure.

1.3 Adaptive Data Collection in Context of Real-time Monitoring of LV-grids

For applications such as DM, VC, and DSSE, the SM data needs to be used in near real-time with different time-horizons. The update rate requirement varies accordingly ranging from a few seconds for grid state estimation to few minutes for DM. The actual measurement and data transmission frequency of the individual SMs may, however, depend on various factors due to the dynamic AMI communication network.

Adaptive data collection is regarded as data collection functionality which reacts to changes in the communication network and electrical behavior for efficient use of communication resources. The approach suggested in this thesis for monitoring of LV grid by adaptive data collection mechanisms is concentrating on employing AMI with the adaptivity of update rates on metering information. At present, in Denmark, most of the SMs installed are used for purposes of billing with a meter reading at long update rates from 6 hours to once or twice a day [18]. The contribution of this Ph.D. dissertation is to study how we can access smart meter data with short time granularity and investigate configurations of access procedures and the influence on the quality of SM measurement data for real-time monitoring applications.

1.4 Problem Statement

The growing penetration of RES in low voltage grid has brought new challenges presented above in ensuring normal operational conditions due to the dynamic nature of the electrical grid and low bandwidth AMI communication. For higher layer monitoring applications, it is evident that more accessible and frequent access to the state of these systems is hugely beneficial. The PhD dissertation aims to investigate:

It is hypothesized that by collecting and providing high-quality SM data, real-time monitoring of the low voltage distribution grid can be supported.

The problem statement leads to the following questions used to guide the studies performed in the dissertation:

1. ***How can adaptive SM data collection mechanism be designed to support real-time monitoring?***
 - (a) How to design an adaptive data collection algorithm that considers communication and grid dynamics?
 - (b) Can information quality metric be useful for designing adaptive data collection algorithms?
2. ***What is the impact of imperfect SM data collection mechanism on real-time monitoring applications:***
 - (a) How to evaluate DSSE utilizing near-real-time SM data?
 - (b) How to evaluate detection of cyber attacks for voltage control using SM data?
 - (c) How to evaluate DM systems utilizing SM data with imperfect communication network conditions?
3. ***How can real-time monitoring applications utilizing SM data be evaluated:***

- (a) How can AMI and communication network emulation systems be realized in a co-domain real-time evaluation framework involving electrical grid subsystems?
- (b) How to model information quality metric for simulating adaptive data collection mechanisms?

1.5 Summary of Contributions

The following section presents a summary of the studies conducted to address the research problems mentioned above.

Adaptive SM Data Collection (in publications **C** and **D**, relating to research problems **1a** and **1b**): Publication **C** introduced adaptation functionalities for proactive SM data collection mechanisms. For this purpose, a two-layer information quality-aware, proactive, smart metering data access infrastructure is simulated. The paper employed Mismatch Probability (mmPr) as a metric for information quality and conducted the quantitative analysis of two-layer data access system simulated in MATLAB. Publication **D** presented a reactive SM data access method. The paper presented an optimized data access algorithm for adaptive scheduling of reactive SM data access. Information quality metric, mmPr is used for designing the optimized scheduling algorithm. A systematic parametric study showed improved information quality for voltage quality monitoring use case. Chapter 4 presents further discussion.

Assesment of LV-grid Monitoring Applications (in publications **E,F** and **G**, relating to research problems **2a**, **2b** and **2c**): Publication **E** presents evaluation of LV DSSE focusing on the trade-off between collective impact of the number of accessed smart meters on the accuracy and delay of the monitoring application. The concept of embedding periodical data collection for monitoring purposes utilizing idle periods of legacy smart meter systems is proposed in the paper. Publication **F** presented an assessment of model-free detection of cyber attacks on voltage control in distribution grids. For that, the paper presents design and simulation of three common types of cyber attacks by adversaries: denial of service, replay and integrity attacks. The effectiveness of a PASAD, a model-free detection system on detecting common types of cyber attacks is studied. Chapter 5 presents a further discussion.

Publication **G** explored how demand management employs the exchange of data and conducts interaction among different control functions to realize goals that can differ in various application contexts. The paper utilized demand management architecture to develop and evaluate a set of algorithms that combine the optimization of energy costs in situations of variable day-ahead prices intending to enhance the reliability of LV grid. The contribution for the thesis is real-time verification of the DM application by using Hardware in the loop (HIL) platform to quantitatively show the improvement of power quality in LV grid by the DM functions.

Co-domain Simulation for Evaluation of LV Grids (simulation and emulation models in publications **A** to **G**, relating to research problems **3a** and **3b**): Publication **A** presented the architecture and setup of a real-time open access platform for towards proof of concept of smart grid applications implemented at Smart Energy System Lab at Aalborg University. The paper presents the three main layers: electrical grid, ICT and, network emulation and control layer. The publication also presented DiSC-OPAL, which is a simulation framework for the real-time evaluation of LV grids including models for an extensive range of assets, stochastic sources of renewable energy for solar and wind power plants and actual consumption data. To present real-life implementation of the whole system, an assessment of two test cases focused on control and market integration of LV distribution grid is presented.

Publication **B** outlines the design of network emulation platform for monitoring of heterogeneous communication technologies implemented at Smart Energy Systems (SES) lab. It proposes a model with three main units, a network emulator used to emulate dynamic communication conditions, a graphical user interface to visualize, configure and monitor the emulated scenarios and a network socket connecting the graphics server with network emulation server. Besides, Publications **C**, **D**, **F** present simulation models for three AMI data access systems which are coupled with a reference LV grid model based on measurement data from a Danish grid explained further detailed in Chapter 3.

List of contributing publications attached to this thesis:

- A. A Real-Time Open Access Platform Towards Proof of Concept for Smart Grid Applications. / Kemal, Mohammed Seifu; Petersen, Lennart; Iov, Florin; Olsen, Rasmus Løvenstein. In: Journal of Communication, Navigation, Sensing and Services, Vol. 2017, No. 1, 3, 19.02.2018, p. 49-74
- B. On-line Configuration of Network Emulator for Intelligent Energy System Testbed Applications. / Kemal, Mohammed Seifu; Iov, Florin; Olsen, Rasmus Løvenstein; Kristensen, Thomas le Fevre; Apostolopoulos, Christos. In: IEEE AFRICON 2015. IEEE Press, 2015
- C. Information Quality Aware Data Collection for Adaptive Monitoring of Distribution Grids. / Kemal, Mohammed Seifu; Olsen, Rasmus Løvenstein; Schwefel, Hans-Peter. In: SGIoT: The 1st EAI International Conference on Smart Grid Assisted Internet of Things. EAI - European Alliance for Innovation, 2017
- D. Optimized Scheduling of Smart Meter Data Access: A Parametric Study. / Kemal, Mohammed Seifu; Olsen, Rasmus Løvenstein; Schwefel, Hans-Peter. In: 2018 IEEE International Conference on Communications, Control, and Computing Technologies for Smart Grids (SmartGridComm). IEEE, 2018.
- E. On the trade-off between timeliness and accuracy for low voltage distribution system grid monitoring utilizing smart meter data. / Kemal, Mohammed Seifu;

Martin-Loeches, Ruben Sánchez, Iov, Florin; Olsen, Rasmus Løvenstein and Schwefel. Submitted to: IEEE Transactions on Industrial Informatics journal, ISSN: 1551-3203, 2019

- F. Model-Free Detection of Cyberattacks on Voltage Control in Distribution Grids. / Kemal, Mohammed Seifu; Aoudi, Wissam; Olsen, Rasmus; Almgren, Magnus. Submitted to: European Dependability Computing Conference, EDCC 2019.
- G. Distributed Flexibility Management Targeting Energy Cost and Total Power Limitations in Electricity Distribution Grids. / Bessler, Sanford; Kemal, Mohammed Seifu; Silva, Nuno ; Olsen, Rasmus Løvenstein; Iov, Florin; Drenjanac, Domagoj; Schwefel, Hans-Peter. In: Sustainable Energy, Grids and Networks, Vol. 14, 01.06.2018, p. 35-46

List of related publication not included the thesis:

- i. Enabling smart grid features by enhanced utilization of actual advanced metering infrastructure, / Martin-Loeches, Ruben Sánchez; Pombo, Daniel V; Iov, Florin; Kemal, Mohammed Seifu; Olsen, Rasmus Løvenstein. In: CIRED 2019, 25th International Conference on Electricity Distribution
- ii. Optimized Scheduling of Smart Meter Data Access for Real-time Voltage Quality Monitoring. / Kemal, Mohammed Seifu; Olsen, Rasmus Løvenstein; Schwefel, Hans-Peter. In: 2018 IEEE International Conference on Communications Workshops (ICC Workshops). IEEE, 2018. p. 1-6
- iii. Observability of Low Voltage grids : actual DSOs Challenges and Research Questions. / Martin-Loeches, Ruben Sánchez; Iov, Florin; Kemal, Mohammed Seifu; Stefan, Maria; Olsen, Rasmus Løvenstein. In: Proceedings of the 2017 52nd International Universities' Power Engineering Conference (UPEC). IEEE Press, 2017.
- iv. DiSC-OPAL : A Simulation Framework For Real-time Assessment of Distribution Grids. / Kemal, Mohammed Seifu; Pedersen, Rasmus; Iov, Florin; Olsen, Rasmus Løvenstein. In: 2017 Workshop on Modeling and Simulation of Cyber-Physical Energy Systems (MSCPES). IEEE, 2017.
- v. Adaptive Data Collection Mechanisms for Smart Monitoring of Distribution Grids. / Kemal, Mohammed Seifu; Olsen, Rasmus Løvenstein. Fast Abstracts and Student Forum Proceedings: In: EDCC 2016 - 12th European Dependable Computing Conference. Vol. 12 1. ed. 2016.
- vi. Gateway placement for wireless mesh networks in smart grid network planning. / Kemal, Mohammed S.; Ceocea, Alexandru; Olsen, Rasmus L. Compatibility, Power Electronics and Power Engineering (CPE-POWERENG), In: 2016 10th International Conference on. IEEE, 2016. p. 144-147 7544174.

- vii. Analysis of Timing Requirements for Data Aggregation and Control in Smart Grids. / Kemal, Mohammed Seifu; Olsen, Rasmus Løvenstein. In: Telecommunications Forum (TELFOR), 2014. IEEE, 2014. p. 162-165.

Chapter 2

Background

2.1 Collaborative Projects

This Ph.D. dissertation was conducted as part of three collaborative projects involving the Department of Electronics and the Department of Energy Technology of Aalborg University and multiple Danish and European research institutions involving academia and industry.

2.1.1 REMOTEGRID Project

REliable MOniToring and Estimation of distribution GRID for smart societies (REMOTEGRID) is a Danish project supported by ForskEL where Aalborg University, the DSO Thy-Mors Energi and the metering company Kamstrup are looking to find solutions to challenges incurred at Danish LV-grid due to high integration of renewable energy units [4].

The objective of the project is to enable energy system managers to obtain a cost-effective, flexible, comprehensive and reliable visualised overview of LV distributions grid for near-real-time operations and planning. The plan of achieving this objective is to prove the project hypotheses *'by collecting and providing high-quality data to the operator or any automatized process; delivered data can effectively be used to optimise operational grid processes, whether these are carried out by human beings or machines.'* The project hypothesis is assessed using two methods, a) with a developed demonstration, implemented and running at project partner DSO premises (Thy-Mors Energi of Denmark), which benefit from the technology in their daily operation and grid planning, and b) for safety reasons a real-time test-bed is used at Aalborg University to assess the developed monitoring solutions in a case study of the same Thy-Mors Energi electrical grid. The combined set of objectives for the project is

broken down to three tracks when put together lead to the achievement of the overall project objective as mentioned. Figure 2.1 shows system architecture for the project highlighting the three main tracks presented as follows:

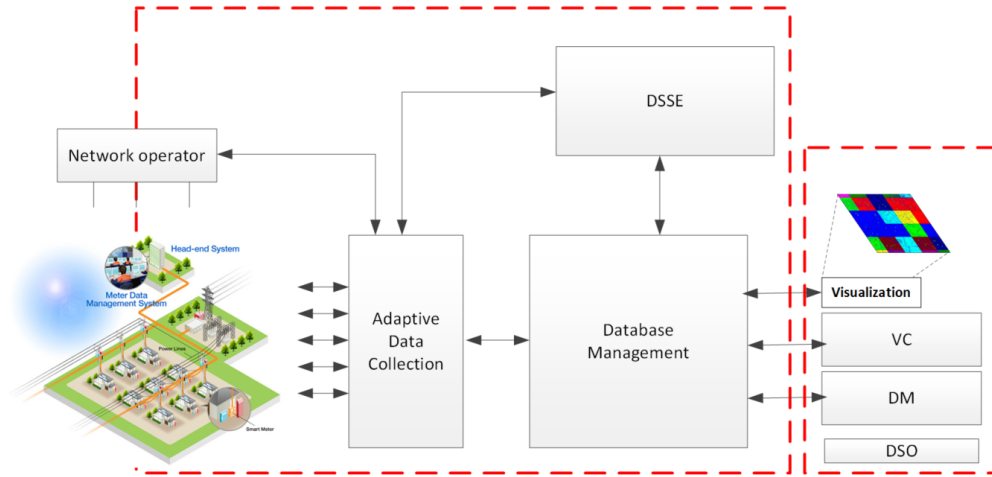

Fig. 2.1: REMOTEGRID system architecture [4]

Adaptive Data Collection and Network Configuration - The technical solution on how to collect data efficiently and securely from the SMs is developed in this track. The focus is on the management of the network and how to configure the data collection system effectively, and solutions based on novel mechanisms relating to meta-data and data quality to the way of accessing data. This happens in close collaboration with the development of the database system, data processing and feature extraction, done in the other tracks since the networking part has an impact and will impact the operations of the different functionalities. Most of the work presented in this thesis is an outcome of this work track, although some of the contributions are in collaborations with other work tracks.

The Database, Data Processing and Visualization - This track provides the technical solution on how to manage a large amount of data, how to store these effectively and extract features from the data sets. This also includes the development of effective ways to visualize relevant data sets, so that they become easily accessible for DSOs. The work of handling the data is tightly coupled to the approach of accessing the data done in the data collection track and will lead to novel interaction of providing highly reliable data that meets given requirements while spending only required network resources for the purpose.

Distribution System State Estimation - In this track, models to perform real-

time estimates of the grid state is developed. These models ensure that high-quality data can be provided at the required time scale and gives certain independence of the performance of the network, although, the link to how the network is configured and data is collected.

2.1.2 SmartC2Net Project

Smart Control of Energy Distribution Grids over Heterogeneous Communication Networks (SmartC2Net) is a European research project under the European Community's Seventh Framework Programme (FP7/20072013). The project involved 7 industrial and academic partners from 5 European countries. The three main objectives of the project are *'1) provide reliable and low-cost energy infrastructure 2) position capabilities of telecommunication operators and energy system integrators in smart grid chain 3) strengthen European research and innovation by bringing together involved stakeholders'* [19]. The project followed various approaches which can be found at [19]. This dissertation contributed to the assessment of smart grid control applications, which are aware of the communication network dynamics and the impact it has on the information quality and reactivity of actuators. Chapter 3 and 5 present the contribution to the real-time testbed used for verification of the control approaches within the project.

2.1.3 Net2DG Project

Leveraging Networked Data for the Digital Electricity Grid (Net2DG) is a project in the European Union's Horizon 2020 research and innovation program with 8 European partners involving Aalborg University. The project objective is to *'develop a proof-of-concept solution based off-the-shelf computing hardware that utilizes available communication technologies to leverage measurements from smart meters, smart inverters in LV-grids. The project strives to develop novel LV grid observability applications for voltage quality, grid operation efficiency and LV grid outage diagnosis'* [20]. Chapter 5 presents an assessment of DSSE application as part of the collaboration within the project.

2.2 Evolution of AMI Infrastructure

An electric meter is an electro-technical device employed to measure the amount of electrical energy used in a place: home or industry. It is used by electricity suppliers to bill the customers for the consumption of energy. Initially, these devices were an electromechanical design which is currently substituted by electronic models. The contemporary versions of electric meters are two-way communicating meters also called "smart meters" [21].

2.2.1 History of Electricity Measurement

- i. **DC Measurement** - Thomas Edison, a supporter of direct current distribution, firstly used an electrolytic counter (Cu / CuS and then Zn / ZnS), the metal deposit being proportional to the current flowing through the circuit (a derivation of the main circuit) [22]. The electrodes were collected and weighed in the laboratories of the producing company (for example, the Pearl Street Station) once a month. Lawrie-Hall developed a modified version for use with alternating current in 1887 [22].
- ii. **AC Measurement** - The first specimen of an AC power meter was presented at the Frankfurt Fair in the autumn of 1889 by the Ganz Companies on the basis of a patent by the Hungarian engineer Ottó Bláthy. It was marketed at the end of the same year, under the name of "Bláthy-meters" [23]. In 1894, Oliver Shallenberger of Westinghouse Electric Company succeeded in using the principle of induction hitherto only used to build ampere-hours- meters to produce a watt-hour meter using a disc whose rotational speed is proportional to the power consumed [24]. In electromechanical meters of the 20th century, the energy metering is done by counting the number of rotations of a drive led by eddy currents [25]. Their operating principle is based on electromagnetism. A movable disk (usually aluminum) mounted on a rotating shaft drives a mechanical counting mechanism. This disk is subjected to the alternating magnetic fields produced by two electromagnets arranged at its periphery with parallel axes, one is traversed by the current flowing in the phase conductor and the other by a current proportional to the voltage of the network [26]. These two magnetic fields, which are in quadrature (shifted by 90°) and directed perpendicular to the disk, induce eddy currents, which, by generating an opposite magnetic field (Lenz-Faraday's law) determine the rotation of the disk. The disc passes between the poles of a permanent magnet, also disposed at its periphery and generating a resistive torque proportional to its rotational speed; the role of this magnet is twofold: it makes the rotational speed of the disk proportional to the instantaneous power and allows the setting of the counter. After calibration, one revolution of the disk determines the counter constant in Wh/ revolution [25].

2.2.2 Evolution of Electricity Meters

- i. **First Generation: Electromechanical Conventional Meters** - These are the oldest counters. They are recognized by their disc which rotates proportionally to the energy consumed. The meters attached using three attachment points. First generation meters are known for their robustness and ease of installation. The meters found currently on the market are refurbished meters [27].
- ii. **Second Generation: Electronic Meters** - Although this type of meter exists

since the 1980s, it is from the 1990s that they appear in the European landscape. The counting system is electronic, and they are often less bulky than conventional meters. The operation is done using a shunt. The voltage measured across this shunt is proportional to the intensity that passes through it. They can be a mechanical display or LCD (digital). These meters are more sensitive to overcurrent and surge, and especially to lightning [27].

- iii. **Third Generation: AMR** - As per reference [4], Automatic Meter Reading (AMR) is the technology of automatically gathering usage, diagnostic, and status statistics from the electric meters and transmitting that information to a central database for troubleshooting, billing, and examining. This technology mostly saves utility suppliers the expenditure on regular trips to each physical area to read a meter. Another benefit is that billing can be founded on near actual consumption instead of on estimations based on past or anticipated consumption. This up-to-date info coupled with examination can assist both customers and utility providers to control the usage and production of electric energy better.

There are several metering devices which employ AMR technology: *Modular counters*: Modular electrical meters have an electronic measuring system. They are compact and easy to install because they are mounted on a DIN rail. The display can be mechanical or LCD (digital) [10].

Central measurement type counters: A datalogger usually gives more information than a simple electricity meter. It typically provides the voltage, the intensity and also measures the harmonics. It often has the memory to record these magnitudes. It also has outputs (RS232, RS485 or Ethernet) that allow it to communicate [10].

Equipment consumption meter: The electrical energy metering device is inserted between the socket and the device whose consumption is to be measured. The counting system is electronic [28].

- iv. **Fourth Generation- Communicating Electric Meter** The latest generation of electric meters offers two-way communications. The main characteristics of these meters are to be able to read, cut and start again distantly. An AMI varies from AMR in that it allows two-way communication between the supplier and the meter. Communications from the meter to the network might be wireless or utilizing fixed wired connections like power line carrier (PLC). As per reference [29], wireless communication options in general usage comprise cellular communications (which can be expensive), Wi-Fi (freely accessible), wireless mesh networks, wireless ad hoc networks over Wi-Fi, ZigBee (low power, low data rate wireless), long-range low power wireless (LORA) and Wi-SUN (Smart Utility Networks).

2.3 Advanced Metering Infrastructure Architecture

Modern AMI infrastructure includes SMs, Data Concentrator (DC) and data management Head End Systems (HES) establishing a new AMI architecture. A simplified high-level architecture, presented in Fig. 2.2, shows SMs connected via common types of communication technologies such as PLC, RF mesh or cellular to a DC. Most AMI systems in Europe utilize the low bandwidth communications such as PLC or RF mesh, but for cases where there is low-density of houses in rural areas, GPRS, 3G or others are utilized. The DC collects SM information via the communication technologies mentioned above and pushes the collected data to HES. Then, the data is prepared at HES in a format accessible to DSOs via a dedicated interface. It is also important to note that there is no overlap between AMI and electrical grid topologies. For instance, some of the SMs in LV grid 2 can be accessed by both DC1 and DC2 as they are within coverage area 1 and coverage area 2.

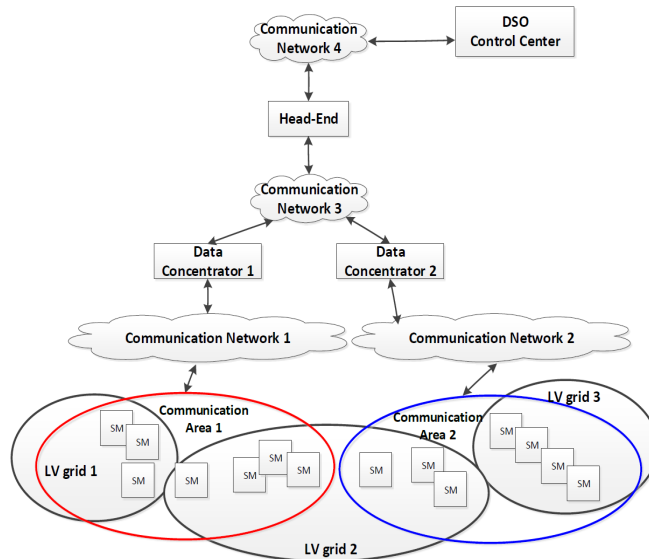

Fig. 2.2: AMI system architecture [30]

2.3.1 Metering Data Access

For access to smart metering data, two dominant modes mentioned in the literature are a push (Proactive) or pull (Reactive) mode to communicate with the layers of AMI.

- i. **Proactive Mode** - The smart meter starts the exchange of message to DC as shown in Fig. 2.3a. Instances of push operations in AMI comprise periodic reading as per pushing data to the concentrators or dispatching push alarms when particular events are recorded by the meter [31].
- ii. **Reactive Mode**: - The smart meter responds to request from concentrators. An instance of pull access is where DC is starting meter reading by sending read request is presented in Fig. 2.3b. The concentrator requests smart meter via Request command and the latter responds with the response information. The data pulling is repeated from all meters occasionally [31].

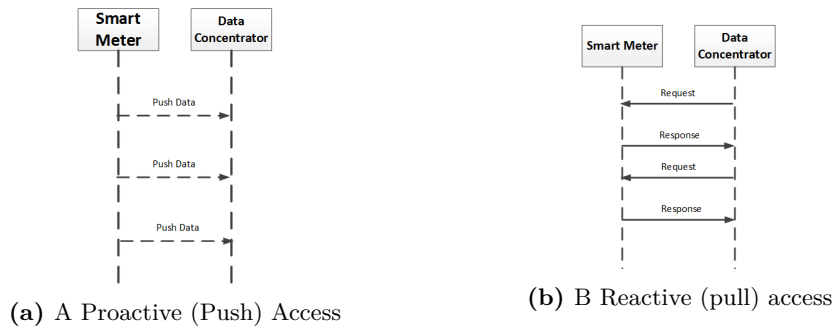

Fig. 2.3: Access Mechanisms

2.3.2 Metering Reading Cycle

To support near real-time monitoring using the existing AMI infrastructure, it is paramount that data from SMs should be collected with small-time granularity. The communication technology used for the study is RF mesh-based systems executing pulling of SM data with multi-hop strategies. RF Mesh infrastructure transmits data over long distances by dividing the range into a series of short hops, using SM nodes as routers in each hop [7]. Figure 2.4 shows the reading cycles for such systems.

The concentrator repeats the pulling of data from all meters periodically with a period of T_{TR} . The DC pulls its current view on the SM measurements from all the SMs in the range which results in with reading time T_r , The Idle time T_i is the remaining time from the fixed total allocated reading time of $T_{TR} = T_r + T_i$. The idle time has some lower threshold value T_{imin} where going below this would affect services executed at an idle time for eg. (potential firmware updates).

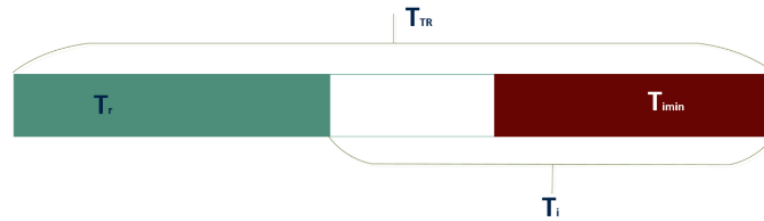

Fig. 2.4: AMI Reading Cycle

2.3.3 Metering Infrastructure Characterization

The smart meter can access a local measurement, which varies value over time. Two kinds of messages reported by the smart meter:

- i. **Periodic Updates** - These are load profiles, mentioning voltage, power and current values to the concentrator regularly. SM presently provides data in slow intervals between every 6 hours to once or twice a day. The load profile logger is reliant on energy readings (both produced and consumed) where the energy to be logged is reliant on the configuration of Smart Meter [4].
- ii. **Grid Events** - These are registers logged by analysis loggers and are either pushed directly to the concentrator or reported with constant measurements [4]. In a traditional AMI system, the concentrator dispatches data to the head-end system which also sends the data to the Distribution System Operators.

2.3.4 Communication Technologies in Advanced Metering Infrastructure

The communication architecture in AMI is hierarchical and multi-layered as put in Fig. 2.2.

The main communication technologies in AMI are:

- **Communication Network 1 and 2:** Network between SMs and concentrators, widely used technologies in Europe are PLC, Radio Mesh and Wireless technologies.
- **Communication Network 3** Communication between DC and HES, Example of widely used technologies include Cellular 3G/4G and Fiber.
- **Communication Network 4:** Communication Network between HES and DSO, Example of widely used technologies include Fiber optic communications.

Standard	Technology	Data rates	Frequency band
PLAN	PLC	200bit/s–2.4 kbps	CENELEC A
Meters&More	PLC	4.8–57.6kbpsn	CENELEC A, ARIB, FCC
PRIME	PLC	21.4–128.6kbps	CENELEC A
1901.2	PLC	Approx. 80 kbps	CENELEC A, ARIB, FCC
G.9902	PLC	Approx. 80 kbps	CENELEC A, ARIB, FCC
RF 1	RF Mesh	Approx. 4.8 kbps	444 MHz unlicensed ISM band
MeshNet3	RF Mesh	9.6 kbps	869.400–869.650 MHz

Table 2.1: Examples of Communication Technologies for AMI in Europe [14]

Since there is a considerable number of highly distributed smart meters located in current LV grid, deploying and maintaining traditional wired communication (such as Ethernet or Fiber) would not be economically feasible for grid operators [15]. DSOs usually deploy low bandwidth and relatively cheaper technologies. Table E.1 presents a comparison of widely used communication technologies for AMI applications in Europe. The table elaborates three categories based on the communication technologies used namely, wireline (PLC), Wireless and RF mesh technologies.

2.4 Information Quality Metrics

Information quality metrics allow to quantitatively represent the quality of information from SMs accessed via AMI to be used as an input for monitoring application. Information quality here is the quality of the content of measured information by SMs. The quality of SM information may be affected by various factors, but in this dissertation, we focus on two main factors namely, grid dynamics and communication dynamics which are defined in Chapter 1. For example, communication network dynamics such as delays and packet losses cause gaps in the collected data which leads to low-quality information. Regarding grid dynamics, for instance, a household with PV tends to show higher variability compared to a household with no PV and could be more useful input for monitoring application. Two information quality metrics are used in this thesis, information age, and mismatch probability.

Information age (in short, age) in this work is defined as the length of the time interval from the time instance at which the SM measures information until the monitoring application at the control center uses this value for computation [30]. Note that information age does not take in to account the behavior of measured SM information over time, for example, impacted by grid dynamics.

Instead of information age, the impact of this age on the information quality, however, can be a more beneficial metric. *Mismatch probability (mmPr)*: in this dissertation is defined as the probability that information at the monitoring application level, during

the time of application execution does not match with the true measurement value at the SM [30]. The mmPr is first introduced in [32] and further used for information quality analysis in [33]. The mmPr metric is beneficial because it captures the impact of both communication dynamic and grid dynamics in one metric. This dissertation proposes a method to improve the information quality by using an adaptation of SM data collection based on mmPr, detailed in Chapter 4.

Chapter 3

Co-domain Simulation for Evaluation of Low Voltage Grids

3.1 Introduction

The increasing penetration of RES such as PV, wind and combined heat pumps (CHP) and the new type of loads such as Electric Vehicles (EV), single connected heat pumps, electric boilers into the Danish electricity supply require advanced design and testing methods [34]. Consequently, real-time hardware in the loop (Hardware-in-the-Loop (HIL)) simulators coupled with ICT and communication network emulation platform can be crucial in this context, allowing researchers to test methods and complex systems associated with smart grid development directly in their labs [35].

Co-domain simulation is also essential as smart grid functionalities necessitate developing, testing and validation of complex systems in an environment that captures the three main areas: Electrical Grid, ICT and Control [34]. The simulation frameworks and tools are anticipated to model flexible assets and Electrical Grid with different resolution levels and time scales satisfying particular functionalities. The dissertation contributes to extension and coupling of evaluation frameworks that cover event-based and time discrete simulation tools and real-time co-domain simulation framework. This chapter summarizes simulation and emulation models utilized for experiments in publications **A** to **G**, relating to research problems **3a**, **How can AMI and communication network emulation systems realized in a co-domain real-time evaluation framework involving electrical grid subsystems?** and **3b**, **How to model information quality metric for simulating adaptive data collection mechanisms?**.

3.2 Simulation Framework

The codomain simulation framework used for experiments in this dissertation is presented in Fig. 3.1. The reference LV grid has 42 buses, 37 households with SMs, 8 PV and 3 controllable assets. The controllable assets are PV systems equipped with energy storage units. Household consumption models are based on real consumption data in Denmark. The monitoring application in focus is a voltage controller where a Low Voltage Grid Controller (LVGC) is located at a secondary substation. The LVGC model is a generalized event-based controller where LVGC starts executing whenever voltage measurements are violated at the controllable assets. The controllable assets send local voltage, minimum and maximum active and reactive power (see [30] for simulation parameters). DiSC, An open source MATLAB based tool is used for the simulation. The tool is developed to verify voltage control in European distribution grids. Details of DiSC with a description of the asset models and consumption data can be found in [13]. Further description and usage of the reference LV grid and control scenario is detailed in [37]. All papers attached to this dissertation use the reference grid except for Paper **E** and with slight modification for paper **G**.

This section presents the contribution to three AMI Data Access System (AMI-DAS) simulations which are coupled with the reference grid model explained above. The coupling is added to investigate 1) The use of mismatch probability as information quality metric in AMI systems to answer research question, **3b** 2) the influence of configuration parameters that can be adapted in AMI data access to answer research question (**1b** detailed in Chapter 4) and 3) detection of cyber attack for research question (**2b** detailed in Chapter 5).

The three presented models as shown in Fig. 3.1 are, first AMI-DAS 1, a simulation model built to evaluate proactive SM data access strategy by modeling an information quality metric (further elaborated in Paper **C**). Second, AMI-DAS 2 simulation of reactive access strategy to assess and propose adaptive scheduling methods using mismatch probability as presented in Paper **D** and [30]. Finally, in AMI-DAS 3, models of cyber attack scenarios are added as an extension of event-based LV grid data collection system implemented for paper **F**.

3.2.1 Simulation of Proactive Smart Meter Data Access

To analyse the information quality of two-level proactive data access strategies in AMI, the dissertation presents the development of stochastic discrete event-based simulation. The model is used for quantitative analysis of a two-layer architecture and analyse dependencies between configuration parameters that can be adapted to the data collection system. Paper **C** considered push access where the SM pushes request to the concentrators. In the push data access, data is retrieved via concentrators that save, aggregate, and forward info from several meters (see Chapter 2.3). We used SM voltage traces

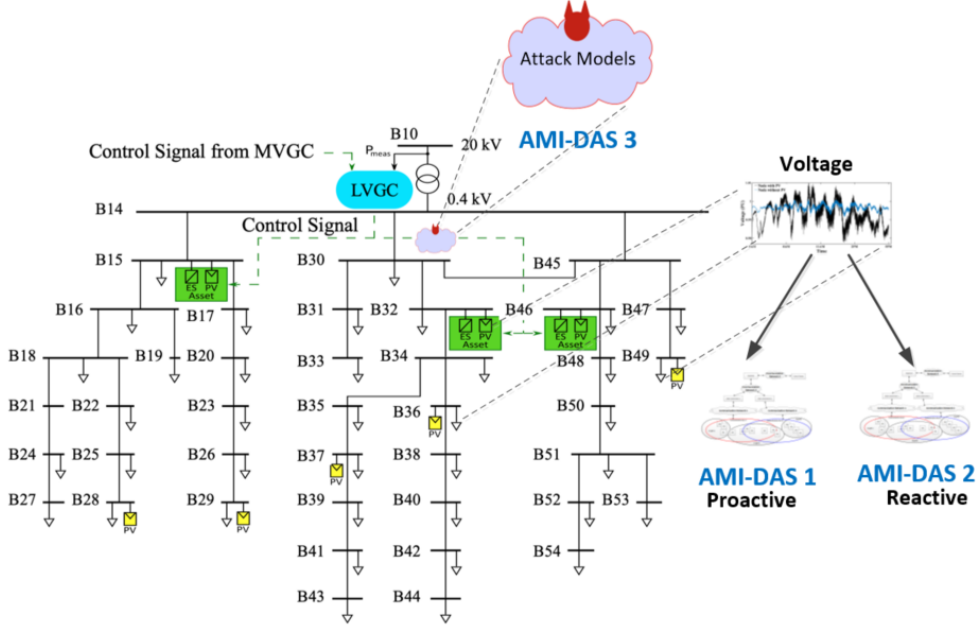

Fig. 3.1: LV reference grid for the simulations adapted from [Paper D].

from the reference grid in Fig. 3.1 to characterize the dynamics of SM information (see Fig. 3.3). A static network model is used to model the communication dynamics for PLC and 3G networks. The model incorporates information quality model, mismatch probability. The contribution includes architecture design, development and test of the simulation platform with full details found in Paper C.

Data Access System Architecture: Smart meter data is typically accessed via DCs that store, aggregate, and forward information from a number of SMs per reading cycle as presented in Chapter 2. That way, a two-level access structure is resulting for proactive SM data access strategies, which is illustrated in Fig. 3.2 and further described as follows. Every SM takes a measurement and sends it to the data concentrator with the rate of τ_{sm} . The SM has the competence to access a local power or voltage which varies value over time represented by E_i and λ as the rate parameter of this process. Likewise, the data concentrator sends its current value on the SM power or voltage to the control layer with an update rate of τ_a . T_c signifies the moments where the controller takes action based on the available information of SM measurements. Communication between every layer is signified by stochastically changing delays with mean values ν_{sm} and ν_a . Details of the architecture can be found in Paper C.

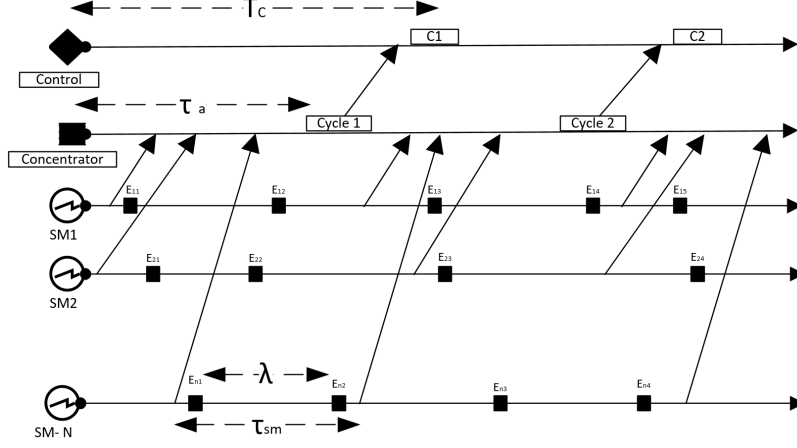

Fig. 3.2: Two level SM proactive data access infrastructure adapted from [Paper C]

3.2.2 Simulation of Reactive Smart Meter Data Access

Paper **D** examined pull access (AMI-DAS 2) in which the SM pulls request from the data concentrators. The data concentrators pull the instantaneous voltage measurements from all SMs periodically. SM information is modelled by using traces from two reference grids, SmartC2Net data for a grid in Denmark and ADRES data for a grid in Austria [19]. The communication network is modelled by static delays inspired by RF mesh and 3G scenarios. Paper **D** presents a detailed description of the models, and the outcome of the analysis is presented in Chapter 4. Contribution includes, architecture design, development and test of the simulation platform in MATLAB.

Data Access System Architecture: A variant of two-layer architecture presented for the proactive case is used here. As shown in Fig. 3.4 the DCs pull the instantaneous voltage values from all SMs with a period of T_{TR} . It takes T_r for the concentrators to pull all SMs in range. The Idle time of $T_I := T_{TR} - T_r$ is the remaining time from the fixed overall allocated reading time. It should be highlighted that T_I has a lower threshold where going below this threshold can affect firmware updates and alarms. A round trip delay of D1 signifies the communication delay between the SM and concentrator. D2 signifies a one-way delay between Head-End and concentrator. The order of sequential pull access by the DC is *schedule* in this dissertation as shown in Fig. 3.4 detailed further in Chapter 5 and in Paper **D**.

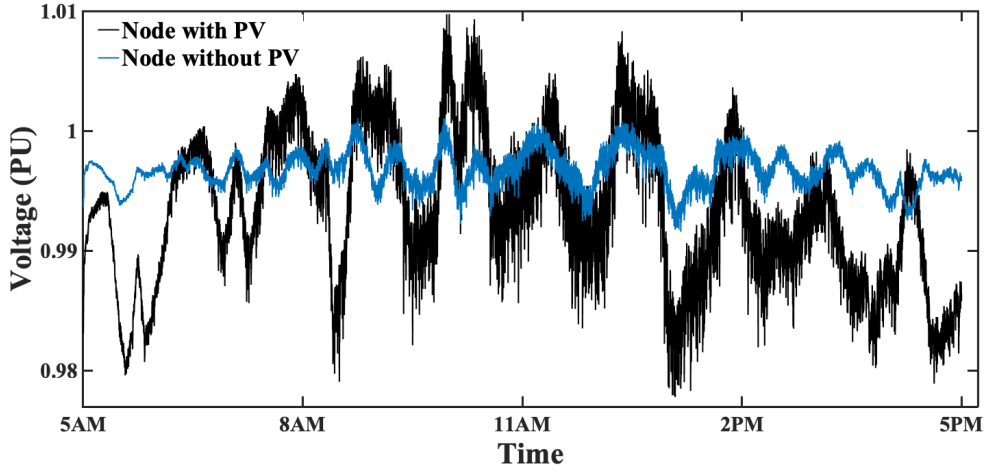

Fig. 3.3: The dynamics of voltage behaviour for two nodes with and without PV systems in the reference grid model [Paper F].

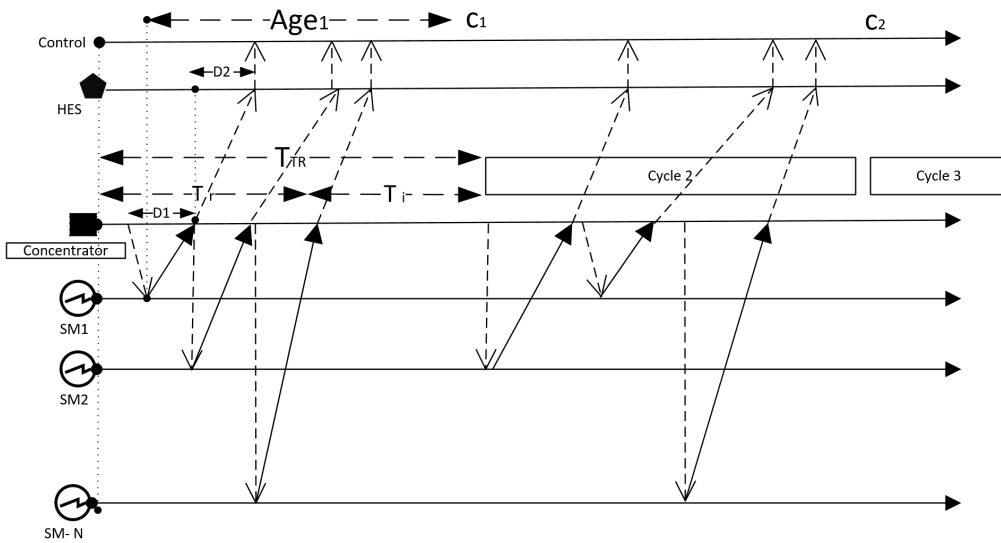

Fig. 3.4: Two Level Reactive Smart Meter Data Access Infrastructure where schedule for cycle 1 is (SM1,SM2,SM3) and while for cycle 2 it is (SM2,SM1,SM3) adapted from [Paper D]

3.2.3 Cyber Attack Models for Voltage Control in Low Voltage Grids

The LVGC in Fig. 3.1 controls the behaviour of the reactive power by communicating control signals (set-points) to the controllable assets. For AMI-DAS 3 presented in Paper **F** presents three common attack types, namely, denial of service, replay, and integrity attacks. The adversary can manipulate the control signals by either compromising the communication link between the controller and the controllable assets or by directly compromising the controller, in which case the assets would execute malicious signals sent by the adversary. On the other hand, the adversary may compromise the SMs and manipulate the SM voltage readings transmitted to the controller, so that the latter reacts erroneously. Contribution for this work includes, an extension of the event-based control simulation shown in Fig. 3.1 and proposed in [37] to model the cyber attack scenarios.

3.3 Contribution to Real-time HIL Testbed

Smart Energy System (SES) Lab of Aalborg University is built with a primary aim to create a platform that can assimilate the prevailing smart energy system demonstrators, real-time hardware in the loop (HIL) platforms, and all associated stakeholders (see Fig. 3.5). The main contribution of the thesis for the platform is 1) design of system architecture and integration of network emulation modules and 2) Integration of monitoring use cases in real-time HIL environment with a focus on active power management and demand management platforms. Before elaborating on the contributions, here is the introduction of SES laboratory:

3.3.1 Background on Real-time HIL Testbed

It is developed to support the three main layers in intelligent power systems: the electrical grid, ICT with communication network emulation, and the control layer [34].

Electrical Grid

OPAL-RT Real-Time Simulator: The main aim of this real-time simulator based on OPAL-RT technology is to attain the electrical system from the transmission level (TSO) down to low voltage distribution grids. Owing to real-time simulation, the user can perform HIL testing with industrial controllers and incorporate realistic communication networks as an interface between physical components and the simulated electrical network [34].

Internal Electrical Grid: The 3-phase voltages measured at a particular point in the simulated distribution network can be implemented to the 50 kVA AC/DC Four



Fig. 3.5: Smart Energy System Laboratory Setup[34]

Quadrant grid simulator providing the physical components, i.e. distributed energy resource, flexible load as they are part of the more extensive system [34].

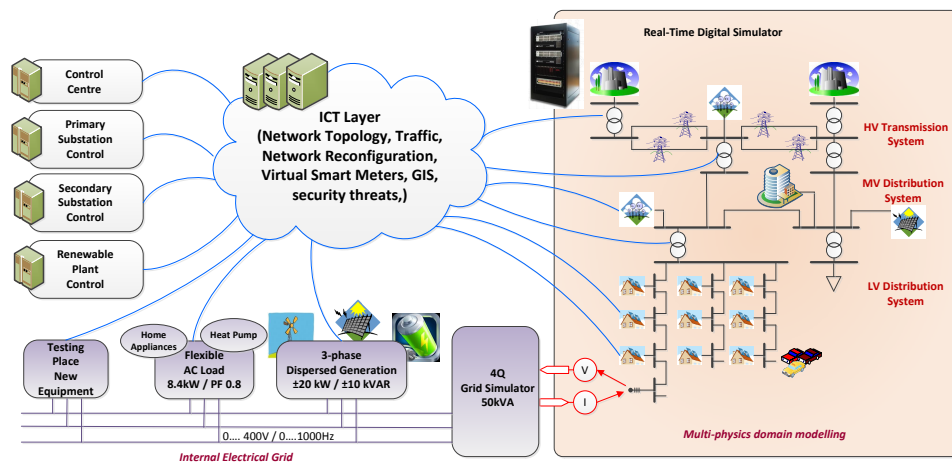

Fig. 3.6: Overview of the Architecture for Smart Energy System Laboratory [Paper A]

ICT Layer

Advancements in ICT and communication network ensure to exchange information and update and monitor the status of each component in the power generation, transmission and distribution systems. A brief description of the main components is presented in the following [34].

Cisco Catalyst 2960xseries Switch: This is a stackable layer 2 and layer 3 access switch placed in the central core of the setup. It has been selected because of ease of deployment, management, troubleshooting and high security (e.g., protects against IPV6 address theft attacks).

Network Server: The network server runs Ubuntu Linux operating system and functions as a router providing NAT and Internet services for the local LAN as well as DHCP functionality, network traffic logs, NTP services, and acts as a network emulator for studying different communication technologies.

CEMS Server: Customer Energy Management System (CEMS) server is dedicated to an application service that communicates with household devices for demand management systems using the standard OpenADR protocol. *Virtual Smart Meter Server:* It is developed to copy multiple real SMs and to allow simulation-based assessment of different automation and control strategies.

Visualization Server: It is employed to facilitate automation of different smart grid applications applied in the setup.

Control Layer

The control layer has components to analyze and model automation, demand response, and control of low voltage grid controller, medium voltage grid controller, primary and secondary substations and plant control unit.

3.3.2 Contribution to Network Emulation Platform

Network emulation is usually employed to assess and examine the performance and behaviour of transport and application layer protocols. Figure 3.7 displays a model for online configuration of network emulation applied at SES testbed. It includes the graphic server employed as the visualization user interface to examine, monitor and configure the emulated situations detailed in Paper **B**. The network server emulates the communication infrastructure utilizing KauNet on a pattern produced from actual experimental tests [39]. The dissertation contributes to the development of the KauNet based network emulation and designing imperfect communication network scenarios for PLC and 3G networks.

One of the main challenges when implementing network emulator is to handle dynamic network patterns. This challenge affects the continuous stream of data which is essential to get information and update the graphics server in real time. So a UDP

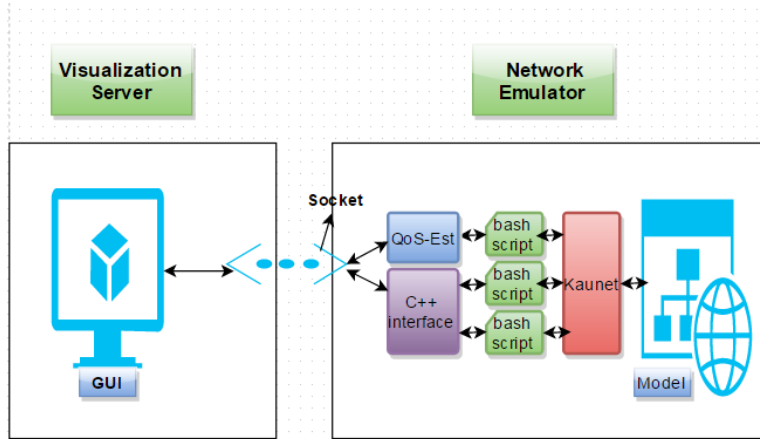

Fig. 3.7: System Model for the On-line Configuration of Network Emulator from [Paper B]

socket connection with C++ interface configuring scripts which create changing network patterns is implemented to send and retrieve data between the visualization server and the Network emulator [39]. Another challenge is the format difference when sending network parameter information from the network emulator to the visualization server. This has been addressed via QoS estimator between KauNet and GUI which translates the network parameter in a format convenient to the GUI.

3.3.3 Contribution to Integration of Use Cases

One of the main contributions here is importing the Matlab based DiSC model to OPAL-RT compatible DiSC-OPAL toolbox. The primary motivation for building this library is as a need for simulation platform which can integrate the three main layers in real-time HIL environment. The main contribution here is to migrate the MATLAB based DiSC tool to Simulink based DiSC-OPAL library. DiSC-OPAL is an OPAL-RT compatible platform to model assets with sampling valid down to 1 Hz [35]. The toolbox comprises models of a wide variety of controllable flexible assets, stochastic wind, and solar irradiance models, real consumption data and electrical grid components. This toolbox is an extension of DiSC, a MATLAB based simulation framework originally built to verify control approaches in power distribution systems. The models are used for realizing two primary use cases, active power management which is presented in Paper A and DM use case presented in paper Paper G and detailed in Chapter 5.

3.4 Active Power Management Use Case

To demonstrate the usage and functionality of DiSC-OPAL library, Paper **A**, and Reference [35] outlined active power management scenario in a real-time environment. The experiments also use the network emulation platform to create non-ideal PLC communication scenarios. The three main functionalities in the context of active power management scenario are Energy balancing, loss minimization, and impact of communication constraints. The OPAL-RT version of the reference grid in Fig.3.1 developed with OPAL-RT for LVGC and Medium Voltage Grid Controller (MVGC). Uncontrollable and controllable assets from DiSC-OPAL were also added on both grids [13].

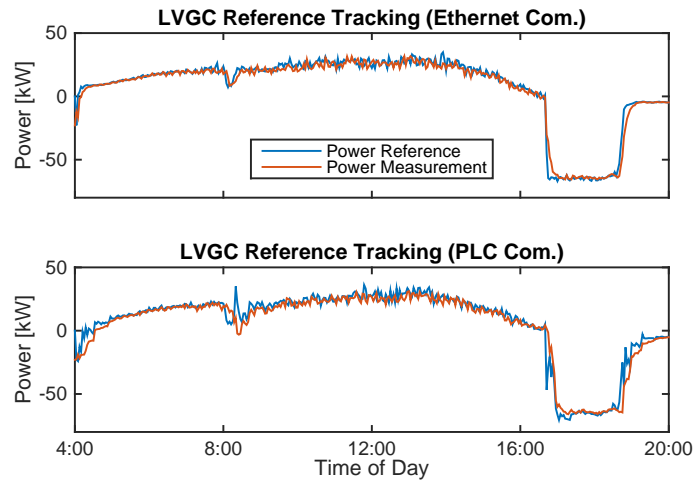

Fig. 3.8: Reference tracking of low voltage grid [Paper A].

Figures 3.8 and 3.9 show a result that contrasts the reference following capability for LVGC and MVGC by employing ideal communication and non-ideal communication. The network emulator delay traces for PLC measurements to realize the non-ideal network case while the typical case uses local high-speed Ethernet. For the ideal case on LVGC, an average error of 4.5 percent is measured, while for the non-ideal case the average error increased to 15.1 percent. The MVGC reference following capability has not been affected as the LVGC case for the reason that ideal communication is implemented between LVGC and MVGC for this specific test-case.

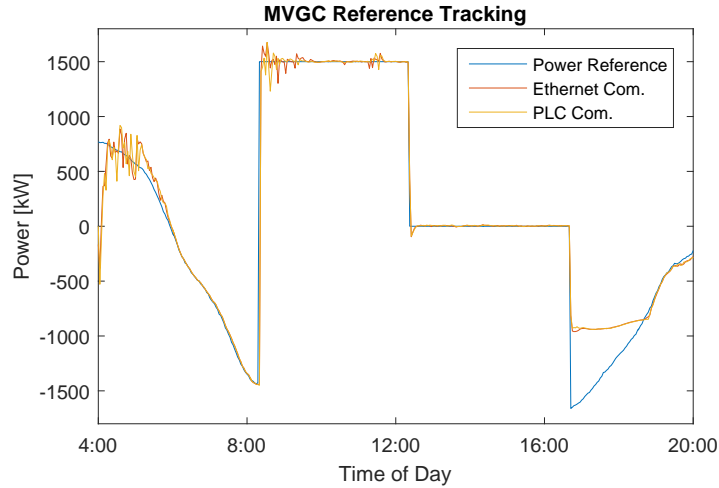

Fig. 3.9: Reference tracking of Medium voltage grid [Paper A]

3.5 Summary

The current LV grids with high penetration of RES and dynamic loads such as Combined Heat Pumps and Electric Vehicles require advanced design and testing methods to implement monitoring applications. This chapter first presents three co-domain simulation frameworks coupled with the reference LV grid model. The focus of the codomain simulation framework is to investigate the use of mmPr as information quality metric to adapt the data collection infrastructure. AMI-DAS 1 simulates information quality aware proactive data access strategies. A reactive data access strategy is implemented in AMI-DAS 2 while cyber attack models are added with AMI-DAS 3. The tool will be used in Chapter 4 and 5 for quantitative analysis experiments.

Real-time simulators coupled with ICT and communication network emulation platform is beneficial to test complex systems and methods related to LV grid monitoring applications in a controlled setup. Coupling an extension of Smart Energy Systems Laboratory is presented with two main contributions 1) Design and implementation of ICT Network Emulation tool and 2) Integration of use cases for real-time verifications. An active power management use case shows how the real-time HIL platform could be used to verify control applications.

Chapter 4

Monitoring of LV Grid Using AMI Data

4.1 Introduction

Smart meters, primarily employed for billing purposes, have the potential to support monitoring applications such as VC, DM, and DSSE applications. But, due to low bandwidth communication technologies between SMs and DCs, it is challenging to get relevant measurements with short-time granularity. This chapter presents the design and analysis of adaptive data collection mechanisms to support near real-time monitoring application using SM data. The key contribution of this chapter is to examine scenarios of access to SM data with short time granularity for proactive and reactive strategies using the system architecture in Chapter 3 and by exploring the ways to model information quality metric that captures both SM information dynamics and the AMI communication dynamics. Chapter 2 introduced the two information quality metrics in focus, the information age and Mismatch probability (mmPr). The study here is to investigate the use of mmPr for adapting AMI data access infrastructure. Moreover, the chapter summarizes contributions in publications **C** and **D**, relating to research problems **1a**, **How to design adaptive data collection algorithm that considers communication and grid dynamics?** and **1b**, **Can information quality metric be useful for designing adaptive data collection algorithms?**

4.2 Information Quality Metric for Adaptive Data Collection

The approach for adaptive data collection of SM data is focused on using the AMI infrastructure with an adaptation of SM access procedures, on using SMs for delivering useful information for monitoring applications. Control application is considered in both proactive and reactive strategies as presented in Chapter 3, where control function is executed during control time (C_i in Equa. 4.1). The mmPr is defined as the probability that voltage value at the controller during control execution does not match with the actual voltage value at the SM at the same time instant:

$$mmPr = Pr(info_{controller}(C_k) \neq info_{SM}(C_k)), \quad (4.1)$$

Chapter 3 presented the system architecture for both reactive and proactive strategies which are used to model mmPr and simulate the AMI data access system. The following sections present a quantitative assessment of the impact of changing SM access configurations on information quality for proactive and reactive cases.

4.3 Adaptation of Smart Meter Update Rates for Proactive Data Access

Monitoring functionalities such as LV voltage control require more frequent access to SM information in comparison to the slow update frequency for billing purposes. As presented in Paper **C**, the goal for adaptivity in proactive data access is to examine how update rate configurations at SM and DC can be utilized for a more frequent data access leading to improved information quality. SM and DC update rates are τ_{sm} and τ_a as explained in proactive data access system architecture in Chapter 3. Paper **C** presents quantitative analysis of dependencies between τ_{sm} and τ_a and how they affect mmPr for variable communication dynamics. The summary here compares the impact of varying τ_{sm} and τ_a on information quality by comparing two scenarios, static delay and variable delay for PLC communication between SM and DC.

4.3.1 Assessment of Static Delay Scenario

The motivation for the reactive SM data access is a control scenario for example analysed in [40] for a power balancing controller. However, the analysis here stays independent of the specific controller realisation as detailed in Paper **D**. For the analysis, the paper uses a stochastic discrete event simulation developed in Matlab. It is assumed that the information element was maintained by a smart metering node and dynamically changed its value at some points with a Poisson process. The communication technology under

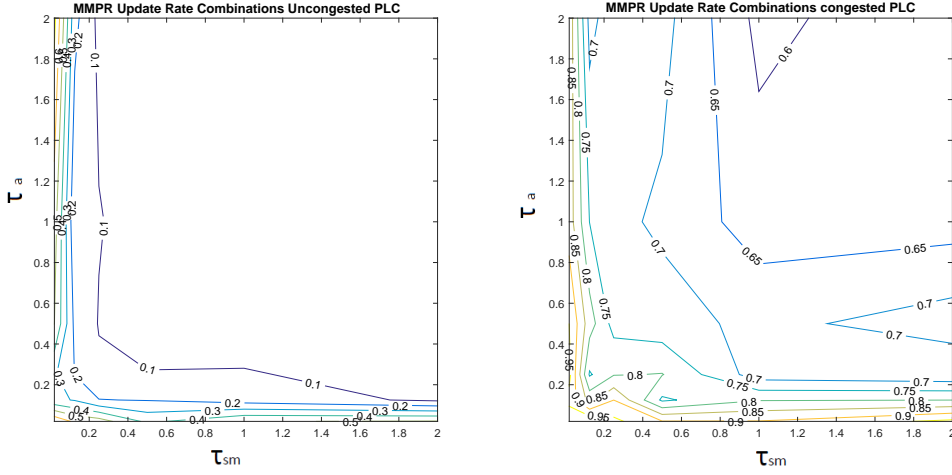

(a) Update Rate Combinations to fulfil mmPR requirement bounds for non congested PLC scenario (b) Update Rate Combinations to fulfil mmPR requirement bounds for congested PLC scenario

Fig. 4.1: Congested vs Non-congested PLC [Paper C]

consideration between SM and DC is non-congested PLC communication characterised by ν_{sm} . Whereas 3G communication is assumed for communication between DC and Controller ν_a . Data access is influenced by the different update rate at SMs and the DC which affect the information quality at the control instances.

To examine how update rate configurations at SM and data concentrator affects the information quality at control instances, we ran a stochastic simulation and vary the update cycles in the ranges 0s to 2s, and $1/\lambda$ of 10s which is derived for a typical household based on statistical studies for residential load modelling done by [41]. We use mean communication delays of 5s and 250ms to study normal PLC and congested PLC. The choices for the PLC scenario are motivated based on experimental studies also presented by [40] [42]. The stochastic values for the change event process and communication delays are iid and exponentially distributed random variables. It can be seen from Figs. 4.1a and 4.1b for both congested and noncongested PLC when any of the update rates go to a zero value, and the mmPr values approach to 1. The increase in mmPr is because of fewer update results in less knowledge of the current state of the SM (greater mismatch). One can see for the congested PLC that, due to long delays small mmPrs of 50% are not even reachable in contrast to the congested one with mmPr of 0.1. As expected, the mmPr values seem to degrade due to the congested PLC scenario on the SM layer. The analysis shows for both congested and noncongested cases; it is

possible to get update rate combinations to minimize the mmPr value, giving improved information quality.

4.3.2 Impact of Load-dependent Delays

In a realistic scenario increased update rate means increased delay due to limited communication bandwidth. Figure 4.2 shows the results of load-dependent delay communication scenario for linearly dependent network model ($\nu_{sm} = a * \tau_{sm} + b$). The values for a and b are chosen to maintain a delay range of 0.2s to 2.5s covering the range for a PLC scenario and τ_{sm} range of 0.02 to 2. One can assume that because of the impact of the update rate combinations of $\tau_{sm}=1/2$ and $\tau_a=2$ led to an mmPr of 1 unlike the relationships for the static delay models in Figs. 4.1a and 4.1b. The circular shape of the mmPr curves in Fig. 4.2 displays a very interesting finding that there is a combination of update rates that gives absolute minimum value for the mmPr; the value of the minimum in these simulation results is between 0.5 and 0.55, and it is achieved for $\tau_{sm} \approx 0.46$ and $\tau_a \approx 0.17$.

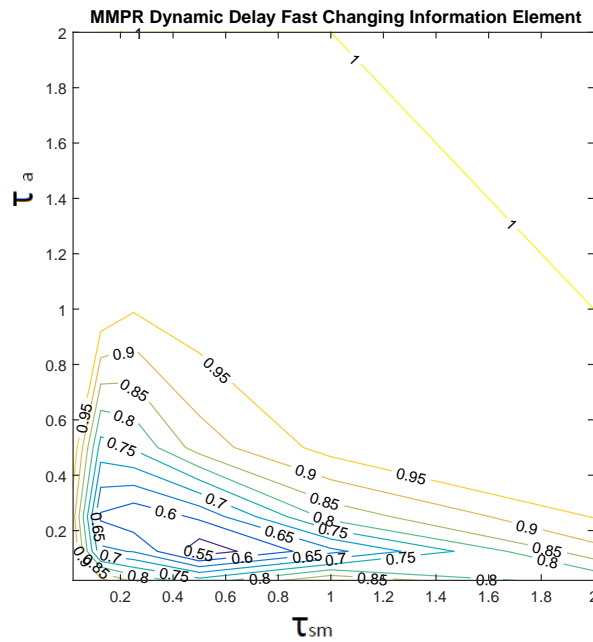

Fig. 4.2: Update rate combinations to fulfil mmPr requirement for linearly dependent delay model [Paper C]

Additional analysis can be found in Paper **C**. The results presented above show that update rate configurations at the smart meter and data concentration layers can be used to improve the quality of SM data. The mmPr metric can be useful as an optimization target to enhance the quality of information and adapt the data collection system. To further strengthen this understanding, the next section presents mmPr based analysis of reactive data access system.

4.4 Adaptive Scheduling of SM Data Using Reactive Data Access

In reactive data access, the SM pulls request from the data concentrator as presented in section 3.3. The constrained AMI networks and current access strategies result in infrequent updates cycles and high latency which strongly affects SM data quality for potential use for real-time applications. For the reactive data access, the order of periodic SM pull access by the DC is called, schedule (see Section 3.2.2). Traditionally, the information age, i.e., time from measurement at SM until the application is utilizing the data, is used to indicate its validity. SM schedule affects information age, but associating the information age to the dynamics of SM information leads to a useful information quality metric, mmPr as presented in Paper **D** and [8]. The main goal of this parametric study is to have an understanding of the impact of SM scheduling on mmPr. To achieve the goal, Paper **D** performs: 1) Study of the impact of scheduling on information age 2) study the dynamicity of SM information by utilizing LV grid voltage measurements based on real data from SmartC2Net and ADRES projects 3) investigate the impact of SM scheduling on mmPr:

4.4.1 Analysis of Dynamicity of Smart Meter Measurements

As shown in Fig. 4.3, Paper **D** demonstrated the information dynamics for selected ten voltage measurements from the reference grid simulation presented in section 3.2. We utilized a sliding window method to obtain the mmPr over increasing information ages. Through the analysis shown in Figure 4.3 mmPr behaves differently for different SMs as the variability of voltage differs at different LV grid points. Two key understanding from the analysis as seen in Fig. 4.3 is, 1) information age influences mmPr in a non-linear manner with different characteristics for different SM nodes and 2) the effect of the information age on mmPr is bounded and not binary (either 0 or 1) but ramps up to values between 0 and 1. It can be seen that as opposed to employing only information age as a metric, the mmPr offers a way to distinguish information from the several SMs and additionally provide an estimation of the appropriate age range that influences mmPr based optimization of scheduling.

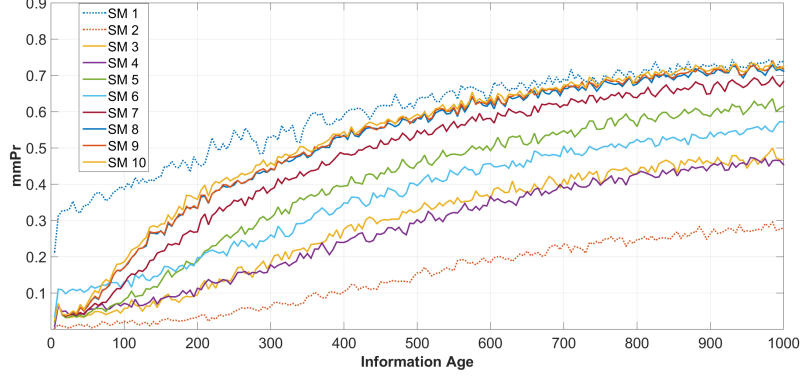

Fig. 4.3: mmPr-information age relationship for 10 SMs from the Sc2Net (SmartC2Net) reference grid from Chapter 3 [Paper D]

4.4.2 Analysis of Scheduling Impact on Information Quality

To analyze the impact of scheduling on information quality, we performed an analysis based on the system in section 3.2.2. For N SMs and deterministic D_1 and D_2 and sufficient idle time $t_I > D_2$, Paper **D** presents the relations:

$$T_r = N \cdot (D_1 + D_{con}) \quad (4.2)$$

$$Age_{min} = T_I + \frac{D_1}{2} + D_{con} \quad (4.3)$$

$$Age_j = Age_{min} + (D_1 + D_{con}) \cdot (N - j) \quad (4.4)$$

$$Age_{max} = Age_{min} + (N - 1) \cdot (D_1 + D_{con}) \quad (4.5)$$

The parameters are configured so that the DC reads through the N SMs in one cycle and up to 10 SMs are used for the study as it is possible to assess all permutations access order combinations. For a higher number of N , the computational effort in determining all permutations becomes high as the effort for the validation of the algorithm grows as order of $O(N!)$ (details in Paper **D**).

Figure 4.4 displays the effect of round trip delay D_1 on the maximum and minimum of the average information quality throughout all schedules. The two different data sets used for the voltage values (Sc2Net and ADRES with detail in Paper **D**) display an overall decay on mmPr margin because of increase in D_1 as anticipated.

The analysis above shows, finding a schedule for SM access that optimizes information quality is a cumbersome task that can be solved by brute force search mechanism

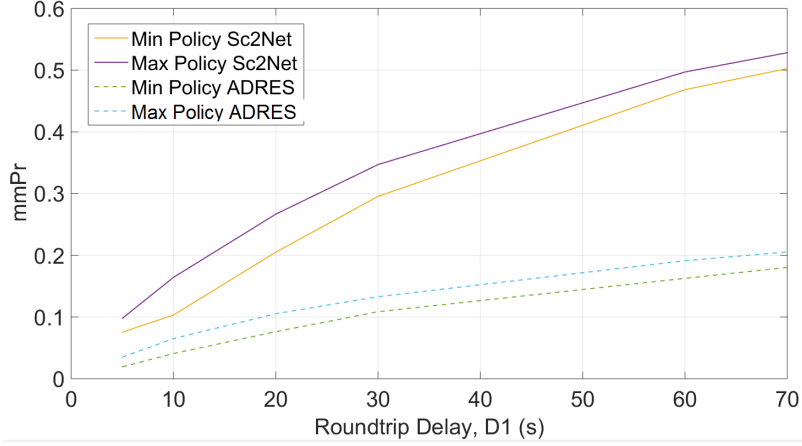

Fig. 4.4: Parametric comparison impact of delay on schedules with absolute min and max mmPrs [Paper D]

only for minimal numbers of SMs (as $N!$ possibilities for N SMs). But, as presented above, the mmPr metric can be used to find the schedules that optimize information quality. The next section shows how a heuristic algorithm uses mmPr to find schedules that improve information quality. Further parametric analysis results are detailed in Paper D.

4.5 Heuristic Scheduling Algorithm for Improved Information Quality

Reference [8] proposes Optimized Scheduling of Smart Meter Data Access Algorithm (ODAS) a heuristic algorithm that clusters the SMs into two groups based on mmPr behavior shown above. The scheduling task for two clusters has an efficient algorithm to obtain an optimal policy, and details of the clustering method can be found in [8]. The pseudo-code for the algorithm is presented in Alg 1. It can be seen that the algorithm takes an information age vector as an input (line 3) for the SM access positions which is pre-calculated using simulation and also approximations of two-step functions. A step function is chosen to limit the number of parameter for the computation. The output of the algorithm is the optimal order of access for the SM scheduling reducing the overall average mmPr of the SMs (high information quality).

Algorithm 1 ODAS [8]

```

1: procedure ODAS
2:   input  $A$  vector  $\leftarrow$  Age Vector for  $N$  SMs
3:   input  $A$  vs  $mmPr$   $\leftarrow$  Step Function 2 class SMs
4:    $AG_1, AG_2 \leftarrow$  Ages for  $mmPr$  jump of 2 classes
5:    $mmPr1, mmPr2 \leftarrow$  height for  $mmPr$  jump of 2 classes
6:   for  $\langle A$  ( between  $AG_1$  and  $AG_2$ )  $\rangle$  do
7:      $\langle$  fill with SM groups with max ( $AG_1$  and  $AG_2$ )  $\rangle$ 
8:   for  $\langle A$   $\langle$  min (  $AG_1$  and  $AG_2$ )  $\rangle$  do
9:      $\langle$  fill with Smart meter groups with max ( $mmPr1$  and  $mmPr2$ )  $\rangle$ 
10:   $\langle$  fill unassigned access out of  $N$  SMs positions  $\rangle$ 

```

4.5.1 Parametric Analysis

In reference [8], ODAS demonstrated improvement when compared to heuristically chosen poor schedules. Paper **D** performed a detailed parametric study for 7 systematically selected cases. Figure 4.5 presents the $mmPr$ comparison for the 7 cases in Paper **D**, in which the ODAS schedule is compared to the average of 10000 selected random policies. On all the cases ODAS outperforms the average of 1000 cases.

To understand further the improvement by ODAS from random policies Paper **D**) introduces the following degradation metrics:

Deg_{min} , relative degradation to the actual minimum $mmPr$:

$$Deg_{min} = \frac{(mmPr - mmPr_{min})}{(mmPr_{min})} \quad (4.6)$$

Deg_{range} , relative degradation to the achievable $mmPr$ range:

$$Deg_{range} = \frac{(mmPr - mmPr_{min})}{(mmPr_{max} - mmPr_{min})} \quad (4.7)$$

Although ODAS outperforms the average $mmPr$ of the selected random schedules, the last column in table 4.1 demonstrates that the suboptimal solution based on the step function approximation does not seem to perform as well in Scenarios 4, 6, and 7 (see Fig. 4.5); these cases should be investigated for further understanding and improvements of ODAS in the future.

4.6 Towards On-line Scheduling Optimization

The heuristic scheduling algorithm presented above uses offline SM measurements to cluster SMs according to their dynamicity. This section presents a conceptual archi-



Fig. 4.5: ODAS is compared to actual min, actual max and randomly selected schedules [Paper D]

Table 4.1: Relative Degradation Comparison [Paper D]

Cases	ODAS		P (ODAS<Random)
	Deg Min	Deg Range	
Case 1	14.65%	24.52%	87%
Case 2	7.73%	15.03%	92%
Case 3	9.64%	32.50%	82%
Case 4	13.32%	44.31%	70%
Case 5	2.69%	29.21%	82%
Case 6	12.27%	71.83%	64%
Case 7	6.27%	50.63%	62%
Case 8	3.48%	18.37%	96%

ecture for online scheduling optimization of SMs for LV grid monitoring application. The architecture incorporates Adaptive Data Dollection Mechanism (ADCM) referring to functionality, eg at HES to adapt the sequential pull of SM information. In Fig. 4.6, ADCM takes as an input the SM selection requirements by the monitoring application and forwards the selection to ODAS. The selection criteria by the monitoring application is out of the scope of this work, but SMs with PVs, for example, could be of interest to the application. ODAS uses SM data from historical measurements, AMI topology information to get the age values for the SMs, and gives as an output the schedule that optimizes the information quality. The ADCM collects SMs based on the schedule to provide the data to a monitoring application

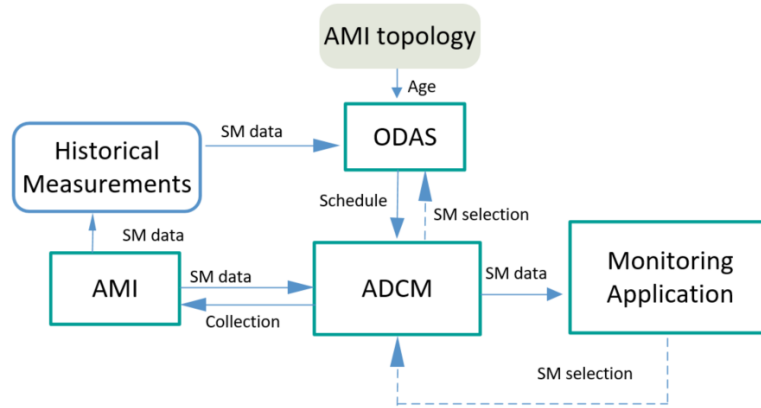

Fig. 4.6: Proposed System Architecture ADCM

4.7 Summary

This chapter presented a general overview of adaptive data collection functionalities for monitoring of distribution grids through the existing smart metering infrastructure. The results in the chapter first show that update rate configurations at a SM and data concentration layers can be used to adapt the data collection system for a proactive data access system. A performance metric $mmPr$ is introduced and used for quantitative analysis of two-layer data access infrastructure.

For a reactive data access system, adapting the order of access of SM by DC influences the quality of the obtained SM data. A heuristic algorithm for adapting SM schedules, called ODAS is introduced. Paper **D** analyses the algorithm in comparison to possible maximum and minimum $mmPr$ by using brute force enumeration of all the schedules. Results show ODAS is in many cases close to the achievable best schedule. For a system with a high number of SM nodes, for which it becomes increasingly difficult to find the optimal solution using brute-force enumeration, Paper **D** argues that ODAS offers a relatively simple and computational more efficient solution.

The analysis and discussion presented above for both reactive and proactive data access method demonstrates that $mmPr$ could be useful for adapting the data access system to support near real-time monitoring applications. The analysis for the proactive SM access showed that the $mmPr$ metric could be helpful as an optimization target to enhance the quality of information by proper configuration of SM and DC update rates. While, for the reactive case, $mmPr$ is used to design a heuristic algorithm ODAS, that optimizes schedules for improved information quality.

Chapter 5

Assessment of LV Grid Applications

5.1 Introduction

When integrating distributed generation in LV grids, there can be several challenges as highlighted by [7] and presented in Chapter 1. First of all, the unpredictable generation from renewable resources challenges the physical and legal limitations of the distribution system and can cause power system congestions or critical voltage variations and VC applications can be beneficial to limit the fluctuations. Secondly, the generation from renewable resources does not necessarily match the peak load of the distribution system, and DM functions could be useful to balance load and demand which for, e.g., leads to improved power quality. Lastly, the flow of power in both directions threatens the operation and safety limit of the LV grid which adds to the need for better observability using monitoring applications such as DSSE. This chapter presents a short summary of the studies performed to answer mainly research questions **2a, How to evaluate DSSE utilizing near-real-time SM data?**, **2b, How to evaluate detection of cyber attacks for voltage control using SM data?** and **2c, How to evaluate DM system utilizing SM data with imperfect communication network conditions?** by publications **E**, **F** and **G** respectively and presented as follows:

5.2 Assessment of Distributed Systems State Estimation

The challenges mentioned above justify the need to adopt a smarter and more dynamic operational approach by using monitoring applications. But as the system operators operate the LV grids from the control centers; this procedure necessitates the attainment of electrical measurements. Chapter 1 presented that collecting from all nodes of LV grids is not achievable and DSSE can fill the gap of the missing measurements. Paper **E** investigated Weighted Least Square (WLS) based DSSE for LV-grids which is widely deployed method in existing medium voltage grids. However, to apply WLS to LV grids, there are challenges such as increased computational needs, prominent numerical instabilities and lack of real-time measurements due to low-bandwidth AMI. Paper **E** investigated 1) The use legacy SM systems for monitoring functions 2) Investigate the use of WLS based DSSE for LV grid monitoring with a focus on the cumulative impact of the number of selected SMs on monitoring system accuracy and its delay.

5.2.1 Embedding Periodical Data Collection in Smart Meter Reading Cycles

In Chapter 2, the basic structure of the SM reading cycle is introduced, and it is shown that the spare idle time can be used to collect data to support monitoring functions. Paper **E** proposed the concept of using the spare idle time ($T_i - T_{imin}$ in Fig. E.4). Figure E.4 presents the concept where access schemes represent the scheme of executing DSSE during the spare idle time. It is assumed that an estimator is executed upon access of R relevant SMs with an allocated time for reading T_{rR} within the spare idle time. Three types of access schemes are exemplified in Fig. E.4. Depending on the choice the strategies give the monitoring system flexibility to run DSSE. For example, an access scheme 1, where DSSE is executed once every reading cycle, means the estimator can have more R as $T_{rR} = (T_i - T_{imin})$ time could be bigger. However, for access scheme 2 and 3 examples, DSSE is executed three times and but $T_{rR} = (T_i - T_{imin})/3$ is shorter as it is divided into 3. Access scheme 1 improves the estimation accuracy with more R while access scheme 2 and 3 give an increased update for monitoring as DSSE is executed 3 times per cycle. In general to execute DSSE R times, the upper bound T_{rR} is $(T_i - T_{imin})/k$. The concept of access schemes can be used to design the monitoring strategy, for example, a periodic estimator can be designed with access scheme 1 and 3 while event triggered estimation can only be designed with a variant of access scheme 3 for a DSSE system to be executed at any time on occurrence of some event.

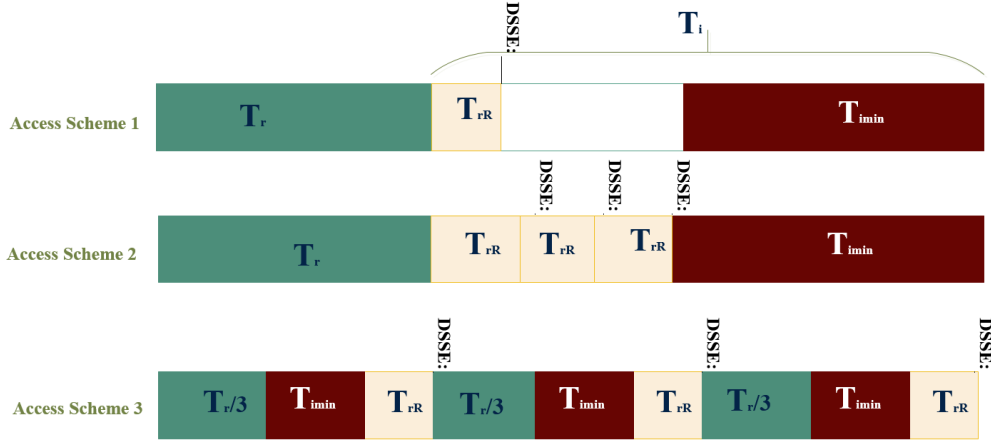

Fig. 5.1: AMI Access Schemes [Paper E]

5.2.2 Trade-off Between Timeliness and Accuracy

The previous section shows the spare idle time has limited capacity to collect relevant SMs. Paper **E** further investigates the combined impact of the number of selected SMs (R) on the DSSE accuracy and the delay to execute DSSE, which is called *timeliness* in the thesis. Timeliness as shown in Fig. E.3 is the time it takes for the data collection system to access R SMs required to execute the DSSE and represented by Δt_R . It is assumed that the DSSE is performed using metering data with the timeliness of Δt_R and the estimated states correspond to the time instant Δt_R seconds in the past.

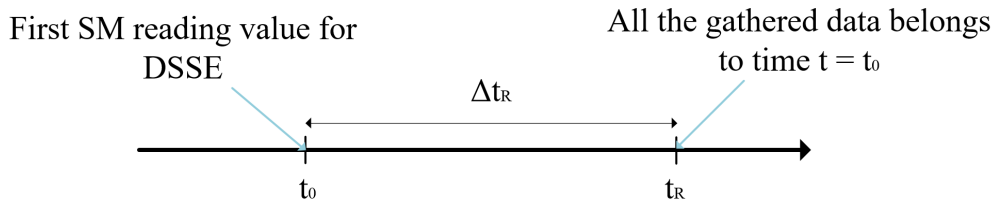

Fig. 5.2: DSSE is executed with timeliness of Δt_R [Paper E]

To quantitatively analyse the relationship between the relevant R SMs on Δt_R , Paper **E** uses the system architecture in Fig. E.5. The presented two-layer architecture shows SMs at the bottom which have access to local measurements, such as root mean squared

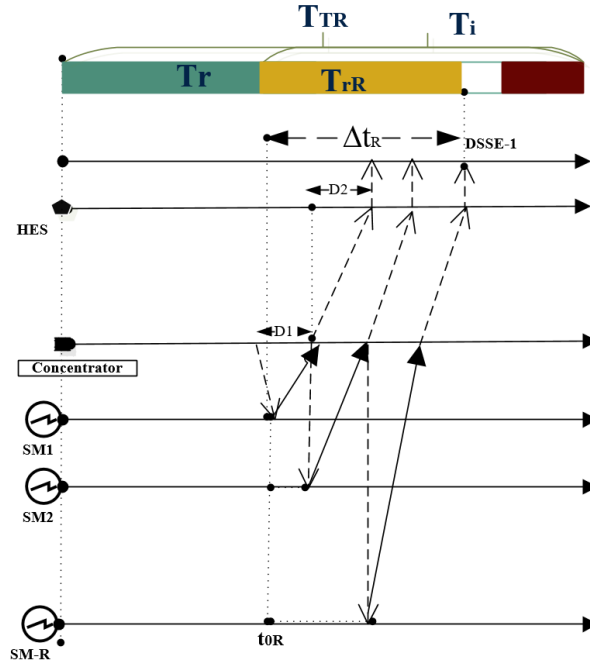

Fig. 5.3: AMI Data Access System Characterization adapted from [Paper E]

(RMS) voltages and currents, energy consumption, etc. per phase. RF mesh technology is the communication technology of interest between SMs and concentrators. The SMs nodes are structured in a mesh topology where each node transmits data over large distances by dividing it into shorter hops creating multihop architecture in-between. D_1 represents the communication delay between SM and concentrator and is affected by the number of hops. It is assumed that the communication technology between DC and head-end-system is 3g. T_{rR} is the allocated time for reading relevant SMs to DSSE and timeliness Δt_R is the maximum time it takes to read R SMs with $\Delta t_R \leq T_{rR}$.

Evaluation of Impact of Size of Selected Smart Meters on Timeliness

The choice of R SMs in Fig. 5.3 affects the timeliness metric as a different group of SMs represent varying topology as SMs are normally located at different geographical locations which can have different path length to the concentrator. Considering that $T_{rR} < (T_i - T_{imin})$, and deterministic single hop communication delays, the resulting Δt_R value is :

1-hop		5-hop		het-hop		All cases	
Case 1	T_{rR}	Case 2	T_{rR}	Case 3	T_{rR}	T_{TR}	T_I
1.1	75s	2.1	375s	3.1	225s	1hr	24min
1.2	90s	2.2	450s	3.2	270s	1hr	24min
1.3	105s	2.3	525s	3.3	315s	1hr	24min
1.4	120s	2.4	600s	3.4	360s	1hr	24min
1.5	135s	2.5	675s	3.5	405s	1hr	24min
1.6	150s	2.6	750s	3.6	450s	1hr	24min
1.7	165s	2.7	825s	3.7	495s	1hr	24min
1.8	180s	2.8	900s	3.8	540s	1hr	24min
1.9	195s	2.9	975s	3.9	585s	1hr	24min
1.10	210s	2.10	1050s	3.10	630s	1hr	24min
1.11	225s	2.11	1125s	3.11	675s	1hr	24min

Table 5.1: Communication topology scenarios, each table corresponds to a different meshed topology [Paper E]

$$\Delta t_R = D_{11}/2 + \sum_{n=2}^R (D_{1n}) + D_2 \quad (5.1)$$

Three main cases are shown in Table 5.1 caused by different AMI communication topologies. The LV grid scenario considered has 20 SMs as in Fig. 5.4. For all cases, the 20SMs are assumed to be connected to a single concentrator. Values for D_1 and D_2 are $D_1 = 10s(perhop)$ and $D_2 = (1/4)s$ inspired by RF mesh and 3G scenarios respectively. The 1-hop case represents that all SMs are 1 hop away from the DC and 5-hop represent that all the 20 SMs are 5 hops away. The heterogeneous scenario is designed in such a way that 20% of SMs located evenly distributed from first to the fifth hop. The choices are inspired by realistic AMI scenarios [4].

The quantitative analysis is focused on answering the following research questions 1) Given T_{rR} , what is the maximum set of SMs to be accommodated? 2) How does the selection of R SMs affect the timeliness metric? The study considers all possible combinations for each case. For example, for case 1.1 there are 77.520 different groupings of SMs fulfilling the T_{rR} requirement. Figure 5.5 shows the maximum, minimum and average values of Δt_R per selection of R SMs. Comparing 1-hop and 5-hop scenario shows the timeliness metric grows for selection of 5-hop R SMs compared to 1 hop as the SMs are further away from the concentrator. Also, the choice of SMs affects Δt_R . For example, given a T_{rR} of 400, one can collect all the 20SMs for the 1-hop case but only collecting 8SMs for the 5-hop. For the heterogeneous case, the maximum number of R one can access around 15 and minimum around 8 depending on the mesh topology of the chosen SMs.

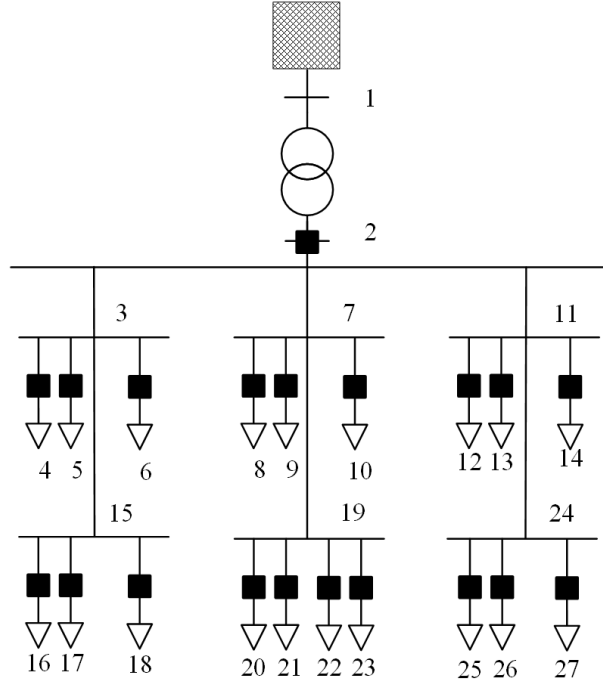

Fig. 5.4: LV Grid Scenario, the black squares represent the position of the 20 SMs [Paper E].

Analysis of Trade-off Between DSSE Accuracy and Timeliness

As summarized in the previous section, the relationship between selected R SMs within T_{rR} affects the timeliness metric. Another interesting research problem is how the selected SMs affect estimation accuracy which leads to a trade-off between Δt_R and estimation accuracy. WLS DSSE is implemented for the study and elaborated in Paper E. The accuracy of the estimator is evaluated by Root Mean Square Error (RMSE) of the estimated voltages \hat{x}_i compared to the true voltages x_i in Equa. 5.2. The considered SM data is active and reactive powers as well as voltage phasors.

$$RMSE_{\hat{x}_i} = \sqrt{\frac{\sum_{n=1}^N (\hat{x}_i - x_i)^2}{N}} \quad (5.2)$$

Figure 5.6 shows the combined plot of the relationship between the number R of the selected SMs compared to the DSSE accuracy. The trend on DSSE accuracy is that generally having more relevant SMs improves the estimation accuracy, further detailed in Paper E. The plot in Fig. E.7 gives an easier way to making SM selection

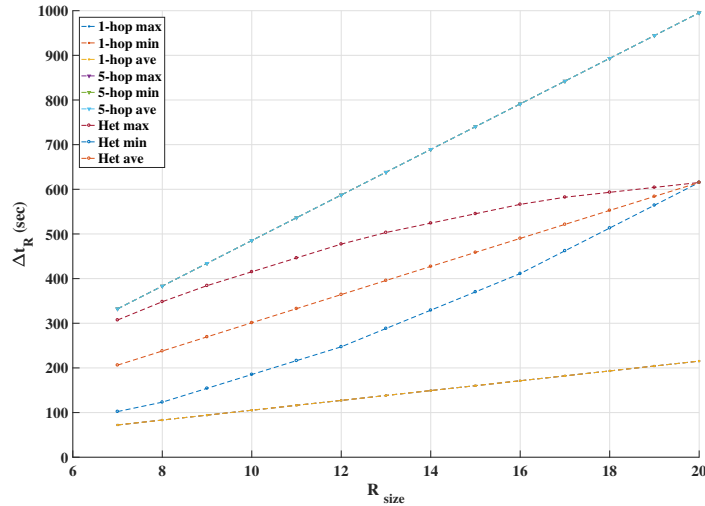

Fig. 5.5: Relationship between number of relevant SMs and the resulting Δt_R for the three communication topology scenarios [Paper E]

decision fulfilling T_{rR} bound and monitoring constraints. Following on the example in the previous section, for T_{rR} limit of 400s, for the 1-hop case, it is possible to access 20SMs which gives the best DSSE accuracy. However, for the 5-hop case, one can only access 8SMs leading to the worst accuracy in the figure. For the heterogeneous case, the best case improves the DSSE accuracy from 0.6% to 0.45% (for R_{10} and R_{15} case respectively). In a real-life scenario, depending on how far the R SMs from the concentrator are located in the AMI topology, the timeliness is affected.

The analysis presented above shows the correlation between DSSE accuracy and the timeliness of estimation. For instance, for SMs 10 hop away from the concentrator, the delay in accessing them is large which contributes to large Δt_R and less DSSE estimation timeliness or lower accuracy. Paper E presented the full procedure to quantify the collective impact of the number of selected SMs on spare idle time of legacy SM systems and estimation accuracy and its timeliness. This knowledge is useful to utilize the existing AMI system for collecting SM data needed for monitoring applications.

5.3 Assessment of Demand Management Application

The concept of Demand Management revolves around the collaboration and exchange of information amid multiple control functions to attain goals that can differ in various

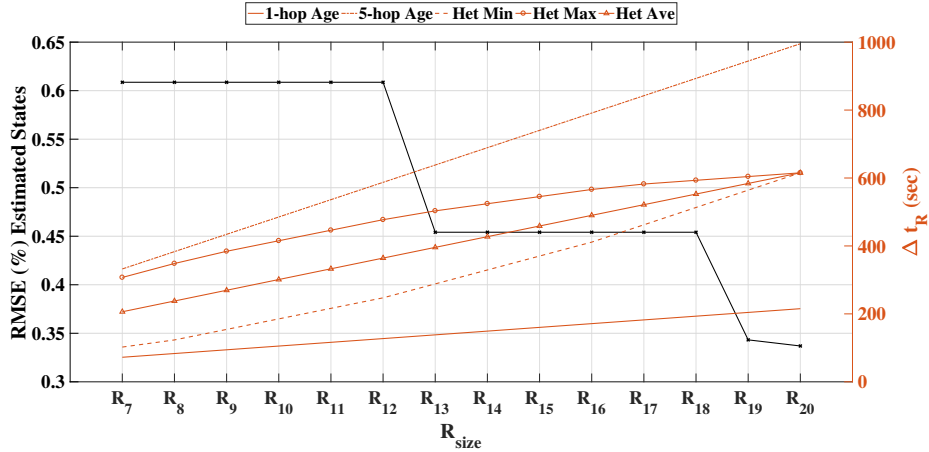

Fig. 5.6: Analysis of the relationship DSSE accuracy vs. timeliness for different sizes of vector R [Paper E].

applications as presented in paper **G**. This is also important because of the different goals and architectures that dynamically manage power demand. The behavior of the Demand Management system can be determined by various entities in a control hierarchy and can be affected by the implemented collaboration protocols. However, this makes the examination of the general integrated system behavior complex and requires careful design and execution. When evaluating the developed algorithms, it should be noted that the DM system is distributed by nature with the ability to exchange information between remote entities through protocols and communication networks. Paper **G** examined the DM algorithms on top of an open industry standard OpenADR via a real-time HIL simulation method presented in Chapter 3 involving communication networks and the reference distribution grid. The HIL simulation demonstrated the effectiveness and convergence of the approach and quantitatively showed an improvement in the power quality in the LV grid.

5.3.1 System Description

Figure 5.7 shows an HIL platform to examine real-time demand management situations. As compared to a hybrid simulation in Paper **G**, the platform integrates an OPAL-RT grid simulation, performs the real communication amid distributed entities through a communication network emulator, and comprises an industrial grid controller which is employed by the DSO to retrieve the metering data at the consumer premises [Paper **G**].

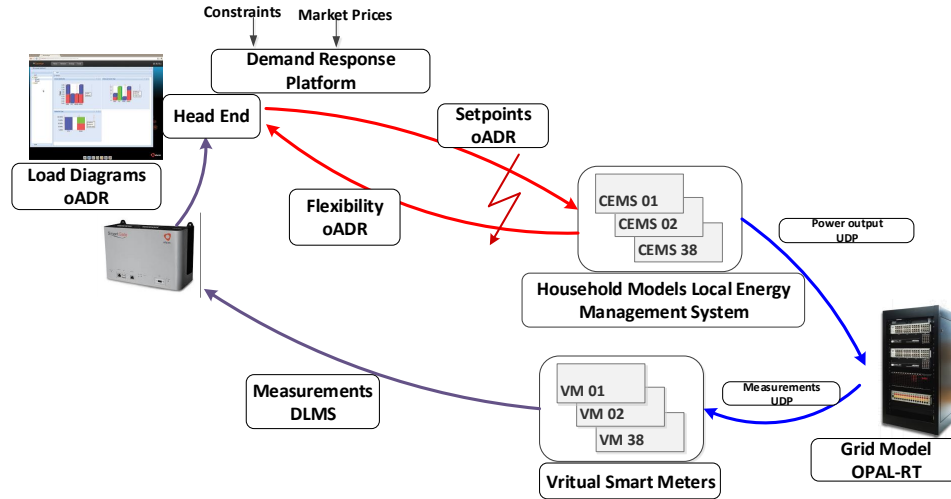

Fig. 5.7: Demand Management Architecture [Paper G]

The smart grid controller retrieves the metering data in Device Language Message Specification (DLMS) format which is communicated to the head-end via OpenADR. All customer energy management controllers (CEMS) and their local asset models run on one dedicated server (see Chapter 3.3.1). The Head-end (HES) and the aggregation controller, operate on a particular machine signifying the demand management controller. Also, the communication network emulator works over a Gigabit Ethernet network as presented in Chapter 3.

5.3.2 Verification Tests

Paper G examined the effect of DM on the voltages at the buses. For this determination, Paper G compared situations with No-Demand Management Controller and Active-Demand Management Controller using a total power limit from the DSO of 70 kW. Figures 5.8 and 5.9 shows 20 h of real-time test performed for both situations, with and without set points from the DM Controller.

Because of the PV generation in LV grid implementation, the voltages at the buses might be higher than the nominal voltage. The drops in Fig. 5.8 and Fig. 5.9 display that because of high household consumption, the voltages can decline, occasionally even less than 95 percent of the nominal voltage for Bus 14. The voltages drop even worse, less than 90 percent, at Bus 38 as this bus is at the end of the feeder. The red lines in the figures display the stochastically similar situation as the blue line, however the DMC is active and employs ideal communication to send set points to the various CEMS units.

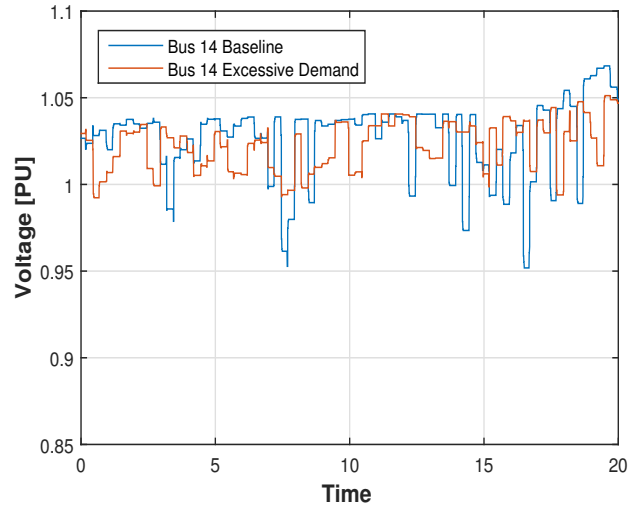

Fig. 5.8: Bus-14 Voltage Traces Baseline Vs Excessive Demand at Secondary Side of Transformer [Paper G]

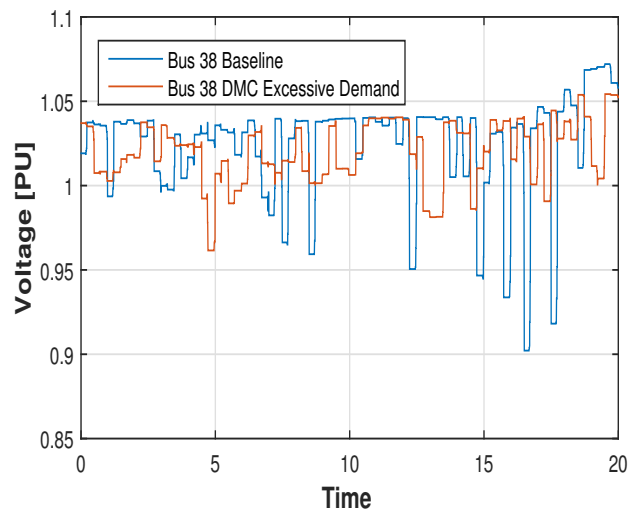

Fig. 5.9: Bus-38 Voltage Traces Baseline Vs Excessive Demand at Feeder end [Paper G]

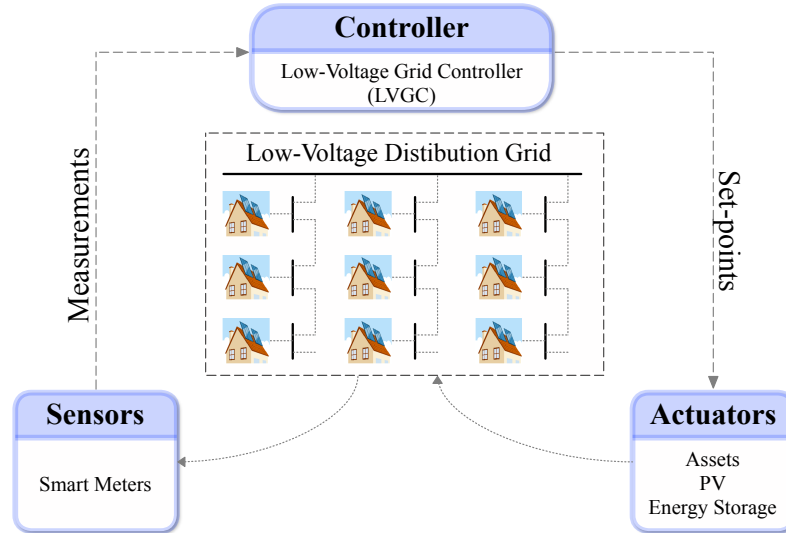

Fig. 5.10: A conceptual control loop for maintaining low-voltage grids within the operational bounds [Paper F].

5.4 Assessment of Detection of Cyberattacks for LV Control Application

Integrating ICT in the LV grid is undoubtedly contributing to more controllable, cost-efficient, and enhanced interfacing for the energy industry. Nevertheless, since this technology is endorsing convenience and flexibility, its incorporation with the LV grid is rendering this vital infrastructure susceptible to cyber-attacks that have potential to generate far-reaching and large-scale damage. So the development of attack-detection mechanisms has become a paramount requirement.

Paper **E** investigated the efficiency of PASAD, a model-free technique, in detecting several types of cyber-attacks on voltage control in LV grids. The results demonstrate that, by monitoring SM and controller signals in real time, the proposed technique is capable of effectively identifying cyber-attacks like Denial of service (DoS), replay, and integrity attacks; consequently, contributing to a more robust LV grid.

5.4.1 System Description

Figure presents a conceptual control loop together with a high-level depiction of the information flow in a particular voltage-control scenario in a grid. Smart meters measuring

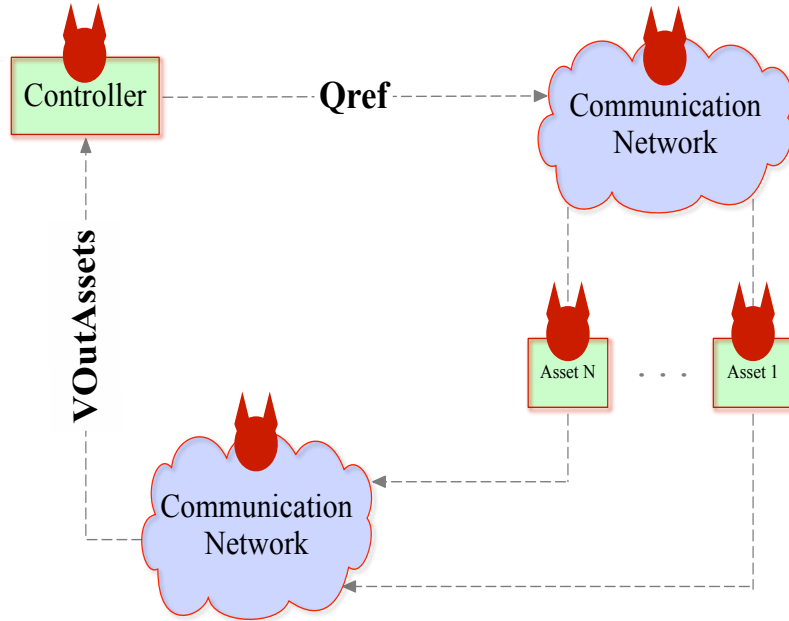

Fig. 5.11: The adversary model [Paper F].

the state of the grid send their readings to a voltage controller over a communication network that is reliable and fast to enhance the usage of controllable assets (combined PV and energy storage units further elaborated in Paper **E**).

5.4.2 Adversary Model and Attack Scenarios

Publication **E** developed an adversary model presented in Fig. 5.11. The voltage control loop is exploitable by an adversary whose aim is to undermine the LV grid. Because of the closed-loop structure, minor malicious changes to the control signals can be iteratively magnified by the control loop, producing a violation of voltage thresholds, drainage of energy storage, and increased system operational costs.

As displayed in Figure 5.11, on the one hand, the adversary can manipulate the control signals Q_{ref} by either directly compromising the controller or by compromising the communication link between the controller and the assets. Alternatively, the adversary might compromise the SMs and manipulate the $V_{OutAssets}$ signals sent to the controller.

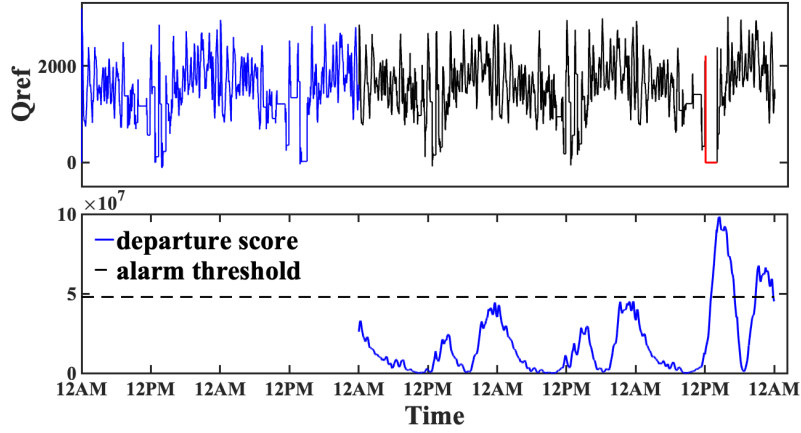

Fig. 5.12: DoS attack on set-points (Q_{ref}) [Paper G].

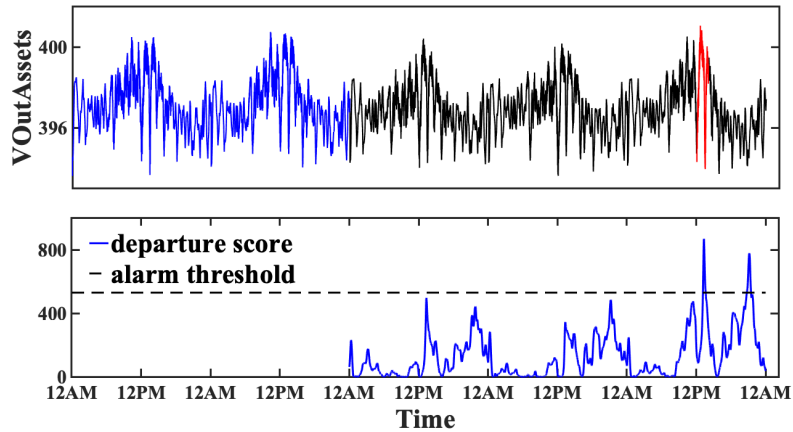

Fig. 5.13: DoS attack on measurements ($V_{OutAssets}$) [Paper F].

5.4.3 Evaluation

The investigated three common types of attack are DoS, replay, and integrity attacks.

- DoS attack is a resource exhausting attack that efficiently interrupts the control of the system in an effort to bring it to an insecure condition.
- In a replay attack, the adversary replays formerly recorded traffic in an effort to fool the controller.
- In an integrity attack, the Q_{ref} signal is wickedly manipulated by the adversary

so that the set-point in the current control loop received by the asset varies from the actual set-point sent by the controller.

The LV grid simulation model used by paper **E** in experiments is an extrapolation of an actual distribution grid in northern Denmark. The simulated grid includes 37 housing units amongst which 3 units have controllable PV systems joined with energy storage (battery), and 8 units had uncontrollable PV systems. To perform the DOS attack, paper **E** assumed that the attacker compromises and switches off the controller for 120 minutes, which causes the Qref signals to become zero during the attack (in Fig. 5.13). The figure shows that PASAD detected the attack in both Qref and VOutAssets.

5.5 Summary

Smart meters widely deployed in current LV grids can be utilized to support for monitoring applications. This chapter presented the use of SM for three kinds of monitoring applications. Firstly, the concept of using the spare idle times of legacy SM data access is introduced. LV-DSSE is evaluated with a focus on the trade-off between DSSE accuracy and its timeliness due to the size of the selection of SMs. The evaluation method shows a procedure to quantify the cumulative impact of the number of selected SMs on DSSE accuracy and its timeliness. Results showed that a small amount of smart meters data could provide fairly good state estimates.

Secondly, It can be concluded that demand management is essential in contemporary LV grids because of different objectives and architectures to handle power demand. The presented distributed demand management architecture can help strengthen grid operations reliability and facilitate easier interfacing with the existing industry standard OpenADR. Lastly, the efficient operation of LV grids demands security and reliability with increased interfacing of ICT systems. The techniques such as PASAD can help to achieve this determination by successfully detecting common cyber-attacks like DDoS, replay and integrity attacks, thus contributing to a more robust LV grid.

Chapter 6

Conclusion and Outlook

This dissertation mainly aimed to investigate the hypothesis: *by collecting and providing high-quality SM data, real-time monitoring of the low voltage distribution grid can be supported.* To perform the investigation, three main contributions are presented in the thesis.

1) Design and analysis of adaptive data collection mechanisms to support near real-time monitoring applications using AMI data. This contribution relates to *collecting and providing high-quality SM data* part of the hypothesis. For this, the dissertation introduced an information quality metric mismatch probability in Chapter 2 first and explained further according to the scope of the thesis in Chapter 4. For quantitative analysis in Chapters 4 and 5, the two-level SM data access structure is presented in Chapter 3. Results via analysis performed in Chapter 4 for static and update rate dependent communication network scenarios show how update rate configuration at SM and DC layer affect information quality and could be used for adapting the data collection scheme. For reactive SM data access, quantitative analysis shows that adapting the order of access at HE to the SM influences the quality of obtained measurement data. The mmPr based heuristic scheduling algorithm called ODAS is proposed to optimize the scheduling of data access of SM by DC. The systematic parametric study shows ODAS algorithm in many cases gives close to the achievable best schedule. ODAS offers a relatively simple and computationally efficient approach to find a good schedule for adaptive SM data access for real-time monitoring applications.

2) Assessment of real-time applications relates to *by providing high-quality SM data, real-time monitoring of the low voltage distribution grid can be supported.* The electrical behavior of current LV grids is transforming because of the increasing integration of RES and new types of loads such as Electric Vehicles and Combined Heat Pumps (CHP). The monitoring application can help tackle some of the challenges faced due to the evolution of the grid. Existing SMs in LV grids, mostly

used for billing purposes, can be used to provide information for the monitoring applications. Chapter 5 presents an assessment of real-time LV grid monitoring applications Distribution System State Estimation, Demand Management, and Attack Detection in Voltage Control.

One of the challenges presented in the thesis is that LV grids are susceptible to short term unpredictable power and voltage variations due to PV or small scale wind power generation. For that voltage control application that utilizes, SM data is assessed in the thesis. Chapter 4 presented mmPr based analysis of the data access system to improve information quality for VC applications. Further, the integration of communication technologies such as AMI systems in LV grids makes the system vulnerable to cyber attacks capable of causing severe damage to the electricity infrastructure. For instance, a likely consequence of malicious modifications by cyber attackers on the AMI system is the collection of erroneous measurements collected from compromised SM nodes, which in turn leads to bad control decisions by the controller. Regarding the challenge of cyber attacks and security of SM data for VC, Chapter 5 presented an investigation of model-free detection of cyber attack for VC applications utilizing SM data. The proposed approach shows promising potential in detecting common types of attacks such as DOS, Replay and integrity attacks. The contribution here is the assessment of the existing anomaly detection mechanism in the context of voltage control in LV-grids.

Another challenge is due to the new loads such as single phase connected heat pumps, electric boilers, or electric vehicles and new generation units such as PV or small scale wind turbines. These new loads and generation units produce new power and voltage profiles with technical challenges such as bidirectional power flows, sudden voltage dips, and swells. DSOs, responsible for maintaining the acceptable operating condition of LV grids require real-time monitoring application. The current metering infrastructure, with low bandwidth communication, cannot provide all measurements needed to support real-time monitoring. Chapter 5 presented Weighted Least Squared (WLS) based state estimator for LV grids that utilizes data collected at the idle periods of legacy SM systems. The investigated WLS DSSE method showed that it is possible to monitor LV grid with limited SM data. The thesis 1) proposes concepts of embedding periodic data collection for DSSE during the spare idle time of legacy SM data collection systems 2) present methodology to quantitatively assess the cumulative impact of the size of data collection for monitoring with estimation accuracy and its timeliness. Results showed an interesting trade-off between DSSE accuracy and its timeliness due to the size of collected SMs.

The third challenge addressed in the dissertation is related to balancing the generation from RES with the load demand in LV grids. Demand management facilitates the cooperation of multiple control functions exchanging information to attain goals such as load shading and cost minimization. The performance of DM application depends on entities in the control layers and the collaboration protocols. Chapter 5 contributed to the assessment of DM architecture that combines optimization of energy costs in

situations of variable day-ahead prices is presented and assessed. Evaluation by using real-time HIL platform showed that DM functions could be utilized to improve power quality in LV grids.

3) Extension and coupling of evaluation frameworks to create a co-domain simulation framework incorporating AMI, electrical grid and communication subsystems. Designing and evaluating the above-proposed systems requires complex testing and design methods, which sparked the development of evaluation frameworks as presented in chapter 3. The chapter presented the contribution for realizing network emulation module by extension of a co-domain real-time evaluation framework. As a use-case, the infrastructure is used to understand the impact of imperfect network conditions on active power management function.

Also, the dissertation contributes to modelling and simulation of AMI data access system with information quality metric to test adaptation functionalities focusing on proactive and reactive strategies in AMI-DAS 1 and AMI-DAS 2. Further, the simulation framework AMI-DAS 2 is used to design optimized data collection methods that utilize mmPr as information quality metric. In AMI-DAS 3, the thesis presents extensions to model cyber attacks for assessment of anomaly detector for LV voltage control applications in Chapter 5.

The results and discussions presented in the thesis open doors for future research problems in the area of real-time monitoring of LV grids utilizing SM data. Some of the research problems are:

1) Regarding design and analysis of adaptive data collection mechanisms:

- The mmPr based quantitative analysis for the proactive SM access takes stochastic assumptions for the SM measurements, and it would be of interest to use real SM measurements for modelling the information dynamics.
- Also for the proactive case, an extension could be to use the understanding of the impact of adapting update rates on information quality for designing a procedure for on-line adaptation of update rates to be used in real systems.
- ODAS algorithm is proposed for 2 class SMs; one future goal could be to extend the algorithm for N class SMs.
- Validation of the quantitative analysis for both proactive and reactive cases in a real-time environment with realistic electrical grid behaviour.

2) Regarding Assessment of real-time applications:

- For the DSSE case, a trade-off is presented between estimation timeliness and accuracy due to the size of access SMs. Next challenge could be to design adaptive data collection mechanism that utilizes the investigated trade-off.

- For the detection of cyber attack analysis, common types of attacks are detected, an interesting research direction is to design stealthier integrity attacks and also investigate detection capabilities for other types of control scenarios such as power balancing and medium voltage control.

3) Regarding extension and coupling of evaluation frameworks to create a co-domain simulation framework:

- The network emulation module in HIL testbed is preconfigured currently, for further robustness of real-time HIL testbed, an extension of network emulation module to support on-line modification of network behaviour would be useful for designing adaptive systems.
- for the testbed, a layer for injecting false data due to cyber attacks and network faults to study security related protocols
- Real-Time hardware in the loop (HIL) integration for validations of the solutions such, mmPr based optimized data access solutions, Weighted Least Squared (WLS) based estimation for LV grids and the detection of cyber attack for VC cases.

References

- [1] Oliver Milman. Carbon emissions must be cut ‘significantly’ by 2020, says un report. URL <https://ourworld.unu.edu/en/carbon-emissions-must-be-cut-significantly-by-2020-says-un-report>.
- [2] Chris Goodall. How to reduce your carbon footprint. URL <https://www.theguardian.com/environment/2017/jan/19/how-to-reduce-carbon-footprin>.
- [4] et al. Einfalt, A. Deployment of grid-connected pv, energinet.dk. URL <http://www.energinet.dk/DA/El/Engrosmarked/Udtraek-af-markedsdata/Sider/Statistik.aspx>.
- [4] REliable MO尼Toring and Estimation of distribution GRID for smart societies. Remotegrid. URL <http://www.remotegrid.dk/>.
- [2] Guido Pepermans, Johan Driesen, Dries Haeseldonckx, Ronnie Belmans, and William D’haeseleer. Distributed generation: definition, benefits and issues. *Energy policy*, 33(6):787–798, 2005.
- [7] Ruben Sanchez, Florin Iov, Mohammed Kemal, Maria Stefan, and Rasmus Olsen. Observability of low voltage grids: Actual dsos challenges and research questions. In *Universities Power Engineering Conference (UPEC), 2017 52nd International*, pages 1–6. IEEE, 2017.
- [3] Maria Stefan, Jose G Lopez, and Rasmus L Olsen. Exploring the potential of modern advanced metering infrastructure in low-voltage grid monitoring systems. In *2018 IEEE International Conference on Big Data (Big Data)*, pages 3543–3548. IEEE, 2018.
- [5] Antonio Gomez-Exposito and Ali Abur. *Power system state estimation: theory and implementation*. CRC press, 2004.
- [9] Mohammed S Kemal and Rasmus L Olsen. Adaptive data collection mechanisms for smart monitoring of distribution grids. *arXiv preprint arXiv:1608.06510*, 2016.
- [10] Syed Khizar Ali Zaidi, Hura Masroor, Syed Rehan Ashraf, and Ahmed Hassan. Design and implementation of low cost electronic prepaid energy meter. In *2008 IEEE International Multitopic Conference*, pages 548–552. IEEE, 2008.
- [11] Vehbi C Gungor, Dilan Sahin, Taskin Kocak, Salih Ergut, Concettina Buccella, Carlo Cecati, and Gerhard P Hancke. Smart grid technologies: Communication technologies and standards. *IEEE transactions on Industrial informatics*, 7(4): 529–539, 2011.

- [12] Florian Skopik, Zhendong Ma, Thomas Bleier, and Helmut Grüneis. A survey on threats and vulnerabilities in smart metering infrastructures. *International Journal of Smart Grid and Clean Energy*, 1(1):22–28, 2012.
- [13] Jonathan Spencer Jones. Denmark – all homes to have smart electric meters by 2020 | smart energy international. <https://www.smart-energy.com/regional-news/europe-uk/denmark-all-homes-to-have-smart-electric-meters-by-2020/>, 2013. (Accessed on 01/03/2019).
- [1] Adrien Saint-Pierre and Pierluigi Mancarella. Active distribution system management: a dual-horizon scheduling framework for dso/tso interface under uncertainty. *IEEE Transactions on Smart Grid*, 8(5):2186–2197, 2017.
- [15] Mislav Findrik, Jesper Groenbaek, and Rasmus L Olsen. Scheduling data access in smart grid networks utilizing context information. In *2014 IEEE International Conference on Smart Grid Communications (SmartGridComm)*, pages 302–307. IEEE, 2014.
- [14] Sabine Erlinghagen, Bill Lichtensteiger, and Jochen Markard. Smart meter communication standards in europe—a comparison. *Renewable and Sustainable Energy Reviews*, 43:1249–1262, 2015.
- [17] Mohammed Seifu Kemal, Wissam Aoudi, Rasmus Olsen, Magnus Almgren, and Hans-Peter Schwefel. Model-free detection of cyberattacks on voltage control in distribution grids. *Ieee Icc 2019*, 2018.
- [18] Abhinandan Jain, Dilip Kumar, and Jyoti Kedia. Smart and intelligent gsm based automatic meter reading system. *Int. J. Engin. Res. Technology (IJERT)*, 1(3), 2012.
- [19] Smart control of energy distribution grids over heterogeneous communication networks. URL <http://www.smartc2net.eu/>.
- [20] Leveraging networked data for the digital electricity grid, net2dg. URL <http://www.net2dg.eu/>.
- [21] Moonsuk Choi, Seongho Ju, and Yonghun Lim. Design of integrated meter reading system based on power-line communication. In *2008 IEEE International Symposium on Power Line Communications and Its Applications*, pages 280–284. IEEE, 2008.
- [22] Andrew B Hargadon and Yellowlees Douglas. When innovations meet institutions: Edison and the design of the electric light. *Administrative science quarterly*, 46(3): 476–501, 2001.

- [23] M Gayatri Lakshmi and S Srivani. Arduino based energy conservation using zigbee and gsm technology. *International Journal of Innovative Technologies*, 3(6), 2015.
- [24] Paul A David and Julie Ann Bunn. The economics of gateway technologies and network evolution: Lessons from electricity supply history. *Information economics and policy*, 3(2):165–202, 1988.
- [25] Nicola Bowler and Yongqiang Huang. Electrical conductivity measurement of metal plates using broadband eddy-current and four-point methods. *Measurement Science and Technology*, 16(11):2193, 2005.
- [26] Peng Weidong and Hu Jingquan. Research of preventing electricity power stealing in single-phase electric watt-hour meter [j]. *Electrical Measurement & Instrumentation*, 2, 2004.
- [27] PAV Loss, MM Lamego, GCD Sousa, and JLF Vieira. A single phase microcontroller based energy meter. In *IMTC/98 Conference Proceedings. IEEE Instrumentation and Measurement Technology Conference. Where Instrumentation is Going (Cat. No. 98CH36222)*, volume 2, pages 797–800. IEEE, 1998.
- [28] Sami Kara, Gerrit Bogdanski, and Wen Li. Electricity metering and monitoring in manufacturing systems. In *Glocalized solutions for sustainability in manufacturing*, pages 1–10. Springer, 2011.
- [29] Vehbi C Gungor, Dilan Sahin, Taskin Kocak, Salih Ergut, Concettina Buccella, Carlo Cecati, and Gerhard P Hancke. Smart grid technologies: Communication technologies and standards. *IEEE transactions on Industrial informatics*, 7(4): 529–539, 2011.
- [30] M. S. Kemal, R. L. Olsen, and H. Schwefel. Optimized scheduling of smart meter data access for real-time voltage quality monitoring. In *2018 IEEE International Conference on Communications Workshops (ICC Workshops)*, pages 1–6, May 2018. doi: 10.1109/ICCW.2018.8403786.
- [31] Young-Jin Kim, Marina Thottan, Vladimir Kolesnikov, and Wonsuck Lee. A secure decentralized data-centric information infrastructure for smart grid. *IEEE Communications Magazine*, 48(11):58–65, 2010.
- [32] Martin Bøgsted, Rasmus L Olsen, and Hans-Peter Schwefel. Probabilistic models for access strategies to dynamic information elements. *Performance Evaluation*, 67(1):43–60, 2010.
- [33] Mislav Findrik, Thomas le Fevre Kristensen, Thomas Hinterhofer, Rasmus L Olsen, and Hans-Peter Schwefel. Information-quality based lv-grid-monitoring framework and its application to power-quality control. In *International Conference on Ad-Hoc Networks and Wireless*, pages 317–329. Springer, 2015.

- [34] Mohammed Kemal, Lennart Petersen, Florin Iov, and Rasmus Løvenstein Olsen. A real-time open access platform towards proof of concept for smart grid applications. *Journal of Communication, Navigation, Sensing and Services (CONASENSE)*, 2017(1):49–74, 2017.
- [35] Mohammed S Kemal, Rasmus Pedersen, Florin Iov, and Rasmus Olsen. Discopal: A simulation framework for real-time assessment of distribution grids. In *2017 Workshop on Modeling and Simulation of Cyber-Physical Energy Systems (MSCPES)*, pages 1–5. IEEE, 2017.
- [13] R. Pedersen, C. Sloth, G. B. Andresen, and R. Wisniewski. DiSC: A Simulation Framework for Distribution System Voltage Control. In *2015 European Control Conference (ECC)*, July 2015.
- [37] Thomas le Fevre Kristensen, Rasmus L Olsen, Jakob G Rasmussen, and Hans-Peter Schwefel. Information access for event-driven smart grid controllers. *Sustainable Energy, Grids and Networks*, 13:78–92, 2018.
- [19] ADRES. onzeptentwicklung fur adres - autonome dezentrale erneuerbare energie systeme, endbericht, wien 2011. URL <https://www.ea.tuwien.ac.at>.
- [39] Mohammed Kemal, Florin Iov, Rasmus Olsen, Thomas Le Fevre, and Christos Apostolopoulos. On-line configuration of network emulator for intelligent energy system testbed applications. In *AFRICON, 2015*, pages 1–4. IEEE, 2015.
- [40] Rasmus Pedersen, Mislav Findrik, Christoffer Sloth, and Hans-Peter Schwefel. Network condition based adaptive control and its application to power balancing in electrical grids. *Sustainable Energy, Grids and Networks*, 10:118–127, 2017.
- [41] Ming Dong, Paulo CM Meira, Wilsun Xu, and Walmir Freitas. An event window based load monitoring technique for smart meters. *IEEE Transactions on Smart Grid*, 3(2):787–796, 2012.
- [42] Mislav Findrik, Rasmus Pedersen, Eduard Hasenleithner, Christoffer Sloth, and Hans-Peter Schwefel. Test-bed assessment of communication technologies for a power-balancing controller. In *2016 IEEE International Energy Conference (ENERGYCON)*, pages 1–6. IEEE, 2016.
- [8] M. S. Kemal, R. L. Olsen, and H. Schwefel. Optimized scheduling of smart meter data access: A parametric study. In *2018 IEEE International Conference on Communications, Control, and Computing Technologies for Smart Grids (Smart-GridComm)*, pages 1–6. IEEE, 2018.
- [6] Mohammed Seifu Kemal, Rasmus Løvenstein Olsen, and Hans-Peter Schwefel. Optimized scheduling of smart meter data access for real-time voltage quality monitoring. *Ieee International Conference on Communications*, 2018.

- [9] J. Zhang and Zhang J. Joint routing and scheduling in multi-radio multi-channel multi-hop wireless net-works.
- [14] Asheesh K. Kumar, Pradeepand Singh. *Grid Codes: Goals and Challenges*, pages 17–39. Springer Singapore, Singapore, 2014.
- [6] M. S. Kemal, R. L. Olsen, and H. Schwefel. Optimized scheduling of smart meter data access: A parametric study. In *2018 IEEE International Conference on Communications, Control, and Computing Technologies for Smart Grids (Smart-GridComm)*, pages 1–6. IEEE, 2018.

Part II

Publications

Paper A

A Real-Time Open Access Platform Towards Proof of Concept for Smart Grid Applications

Mohammed Kemal, Lennart Petersen, Florin Iov and Rasmus Olsen

The paper has been published in the
Journal of Communication, Navigation, Sensing and Services Vol. 2017, pp.49-74,
(ISSN 2246-2139), 2018.

The layout has been revised.

Abstract

This paper presents development of real time open access platform towards proof of concept of smart grid applications deployed at Smart Energy System Laboratory of Aalborg University. Discussed in the paper is the architecture and set-up of the platform by elaborating the three main layers: Electrical grid layer, ICT & network emulation layer and control layer. DiSC-OPAL, a toolbox built for OPAL-RT real time grid simulation; comprising of models for wide variety of controllable flexible assets, stochastic power sources for wind and solar power plants, real consumption data and electrical grid components is presented. A detailed model description of the whole set up and the corresponding functionalities is characterized. To showcase real life application of the whole framework, an overview of two test cases implemented for the European SmartC2Net project, with focus on control and market integration of low voltage distribution grids is presented.

A.1 Introduction

The current fast evolving global intelligent energy system is facing a daunting task of accommodating the major players on energy system infrastructures involving electricity from clean energy sources, intelligent supply of thermal energy, advanced energy storage facilities, and smart integration of the transportation sectors. It has become apparent to transform the energy system planning and strategies for an environmentally friendly and sustainable future [1] [17].

In 2015, Danish wind power generation units produced what corresponds to record breaking 42% of the country's electricity consumption. In Jutland and Funen regions, wind power in fact produced more electricity than the total consumption of 1,460 hours of the year [4]. After the historical 2012 Danish energy agreement with an ambitious goal of supplying 50% of the energy consumption from renewable energy sources, the penetration of distributed photo-voltaic (PV) systems and small wind turbines is increasing at a rapid rate.

This foreseen highly increasing penetration of wind and PV into the Danish electricity supply, imposes the requirement that this large scale renewable generation shall contribute to grid support services such as voltage, frequency and rotor angle stability control in order to ensure the system stability comprising both transmission and distribution level. In particular, the dispersed pattern of wind turbines and PV systems in distribution networks requires coordination of various controls with fast and reliable communication (i.e. between wind power plants and the system operator) to exploit those flexible assets in the medium-voltage (MV) grids [5] [6].

The high complexity of the aforementioned factors calls for advanced design and testing methods. Real-time (RT) simulators coupled with ICT and communication network emulation platform can be crucial in this regard, enabling researchers to test



Fig. A.1: *Smart Energy System Laboratory Setup* [17]

complex systems and methods related to smart grid development directly in their laboratories [3]. There is an urgent need for platforms that can take in to account both ICT layer and real-time grid simulation platform with capabilities to incorporate the key players across all related sectors and create an optimal environment to test new research methods, technologies and practices.

Smart Energy System Laboratory of Aalborg University (Fig. A.2) is built with a major goal to create a platform that can integrate the existing smart energy system demonstrators, real-time hardware in the loop (HIL) platforms, and involving all related stakeholders. This framework is unique because it can be used to incorporate aspects of power system, ICT & communication network and control functionalities simultaneously in real-time. Experimental platforms of this type would provide functionalities to perform complex experiments which would otherwise be impossible to test on a real life conditions.

The paper is structured as follows; Section A.2 illustrates the whole architecture and detailed overview of the layers in the *Smart Energy Systems Laboratory* platform. In Section A.3, practical applications of the setup dealing with Active Power Management, Demand Response platform and Wind Power Plant Voltage Control is presented. Finally Section A.4, summarizes the paper.

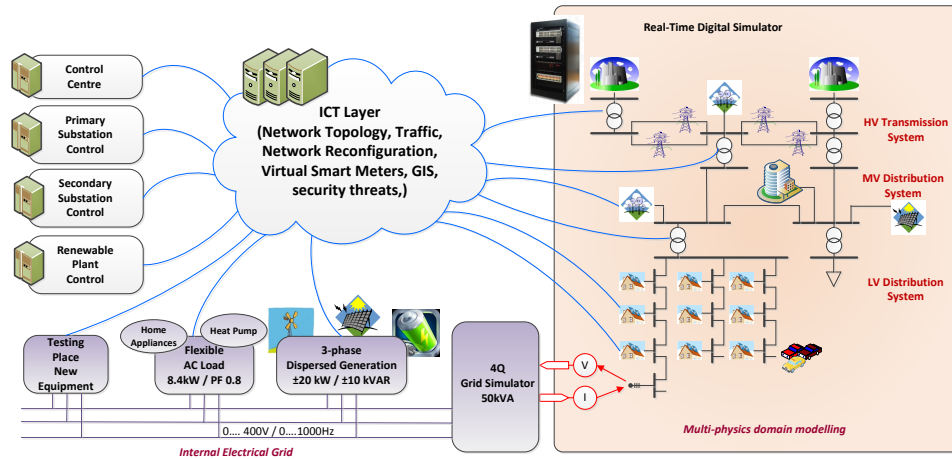

Fig. A.2: Overview of the Architecture for *Smart Energy System Laboratory Setup* [17]

A.2 Smart Energy Systems Laboratory Architecture

Smart Energy Systems Laboratory setup shown at Fig. A.2 is established with the vision to capture an integrated simulation of power and communication networks by using real life actual data to build and test new research findings and technologies.

It is constructed to support the three key layers in intelligent power systems: the electrical grid, ICT with communication network emulation, and the control layer. DiSC-OPAL library, development of a dynamic SIMULINK library toolbox built for OPAL-RT real-time simulation environment is also presented here.

A.2.1 Electrical GRID

The main electrical grid components as seen in Fig. A.2 at *Smart Energy Systems Laboratory* setup are presented as follows,

OPAL-RT Real Time Simulator

Inputs from a real-time digital simulator based on OPAL-RT technology is realizing the simulation of large scale energy networks including various systems using the multi-domain physics approach. Both electrical networks as well as thermal and mechanical

systems can be incorporated. However, the main goal for this real-time simulator in *Smart Energy System Laboratory* is to capture the electrical system from the transmission level (TSO) down to low voltage distribution grids (DSO). The power system algorithms produce output conditions that realistically represent states in a realistic network, making real-time simulation significant for two reasons; the user is capable of performing HIL testing such as with industrial controllers (see Section A.2.4) and realistic communication networks can be incorporated as interface between simulated electrical network and the physical components (see Section A.3). The OPAL-RT is able to simulate up to 10000 three-phase buses in RMS and 600 nodes in EMT. Implementation of all models is based on Matlab/Simulink.

For the test-cases in Section A.3, a medium voltage and low voltage network as part of a benchmark distribution grid used for *SmartC2net* is implemented on OPAL-RT simulation platform. Controllable and uncontrollable assets are added to the benchmark grid, as shown in Fig. A.3 (MV grid) and Fig. A.4 (LV grid). SPP is a 3 MW solar power plant, WPP is a 2.7 MW wind power plant. The low voltage grid controller (LVGC) is managing a LV grid at Bus B10; There are three controllable assets in the MV grid, PV plant connected to bus B4, a WPP connected to bus B11, and a low voltage grid (controlled through the LVGC at bus B10). All the remaining consumptions and productions in the MV grid are implemented according to realistic load profiles.

The controllable assets in the LV grid are three PV systems combined with energy storages. The uncontrollable consumption and production comprise household consumption and five uncontrollable PV systems. The data for the household consumption is given by traces from real consumption data provided in DiSC-OPAL toolbox (see Section A.2.2), which also provides the asset models used for the implementation.

Internal Electrical Grid

The 3-phase voltages measured in a given point in the simulated distribution network in OPAL-RT can be applied to the 50 kVA AC/DC Four Quadrant grid simulator supplying the physical components i.e. dispersed energy resource, flexible load as they are part of the larger system (see Fig. A.2). The three phase currents are fed in back to the real-time digital simulator. A fully regenerative four quadrant power converter is emulating the dispersed generation unit. It has $\pm 20kW / \pm 10kVAR$ capability and it is used to mimic characteristics of a small wind turbine, a PV systems or energy storage. Several controllable flexible AC/DC Loads are used to mimic the behavior of loads in a typical household. This system is receiving set-points from hierarchical control structure (see section A.2.4). Different smart meter technologies are installed on the platform and can provide power and energy consumption from the physical assets to the upper hierarchical control levels.

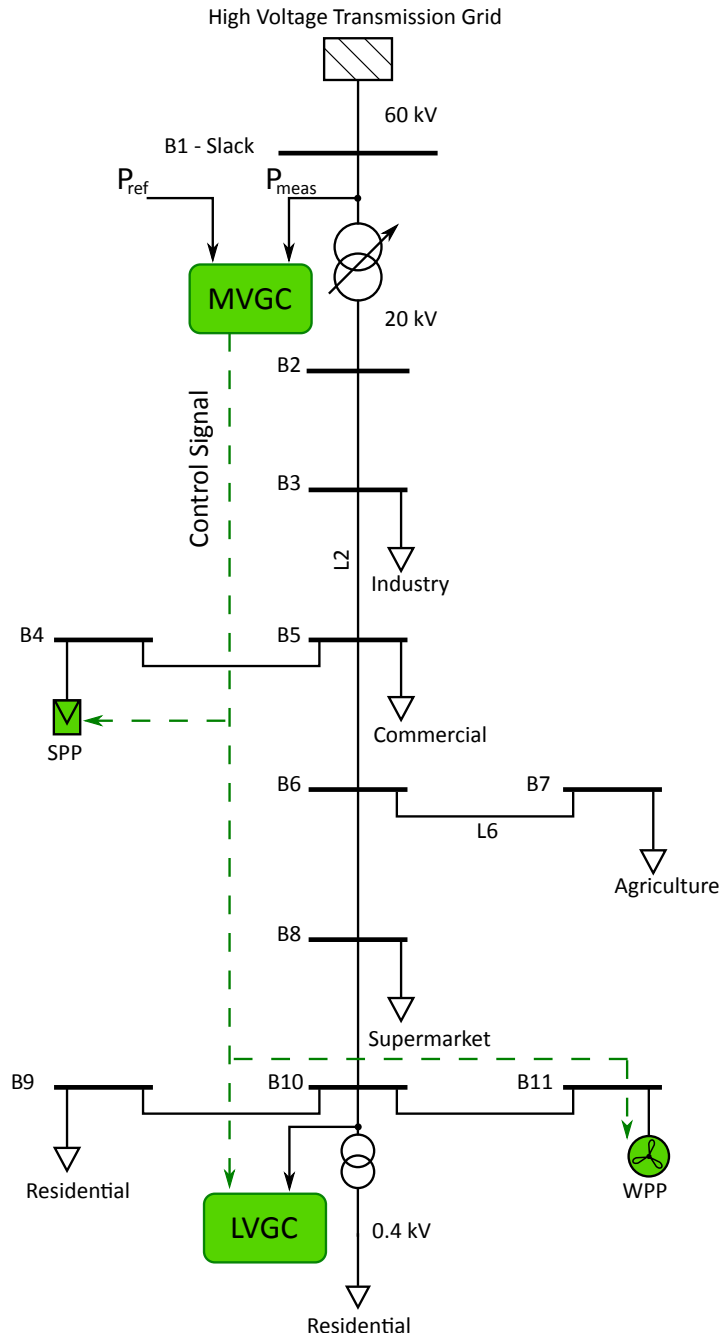

Fig. A.3: Medium voltage distribution grid.

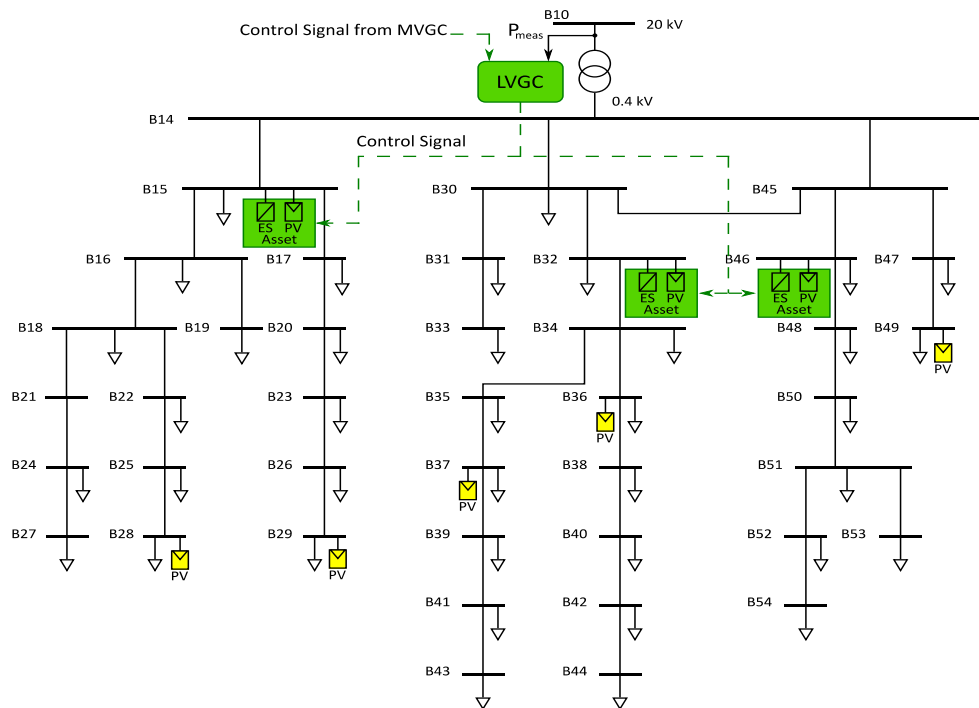

Fig. A.4: Low voltage distribution grid

A.2.2 DiSC-OPAL Toolbox

DiSC-OPAL Toolbox is primarily used to verify voltage control algorithms in power distribution grids during real-time simulations using OPAL-RT, for bandwidth range of less than 0.2Hz. The toolbox comprises SIMULINK models for wide variety of controllable flexible assets, stochastic power sources for wind and PV power plants, real consumption data and electrical grid components (see Fig. A.5). This toolbox is an extension of [5] and [10], a MATLAB based simulation framework originally built to verify voltage control approaches on power distribution systems. DiSC is primarily developed due to the unavailability of similar simulation platforms that can support flexible assets with grid control, models with dynamic consumption patterns and specifically targeted to study voltage control problems. The full platform and related documentation is available on the homepage [10].

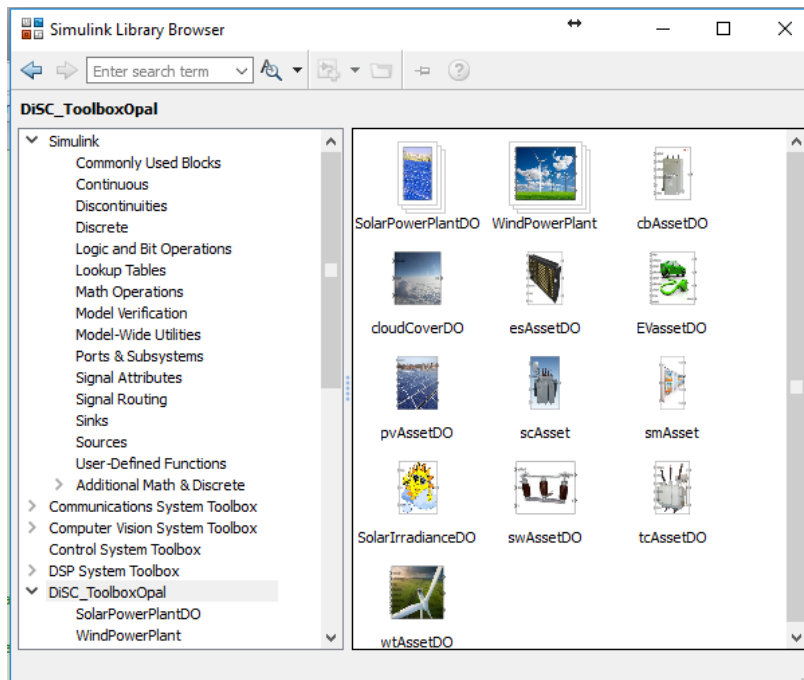

Fig. A.5: A snapshot of DiSC Toolbox for OPAL-RT based on MATLAB/SIMULINK environment [11]

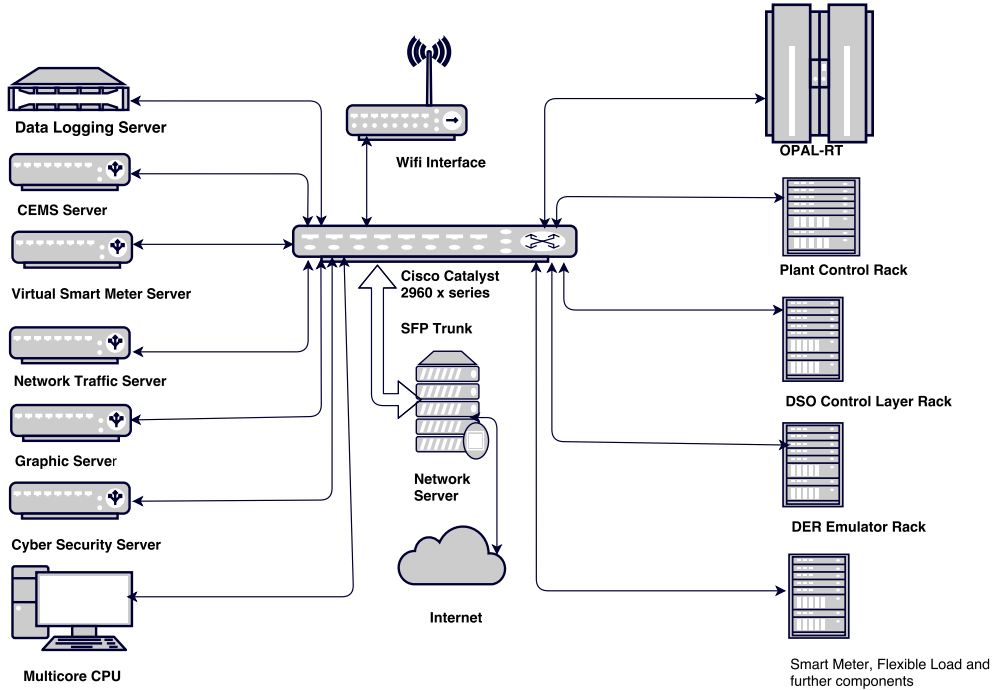

Fig. A.6: Overview of the ICT Setup for *Smart Energy System Laboratory* Laboratory Setup

A.2.3 ICT and Network Emulation

Intelligent energy systems benefit from modern ICT and communication network advancements to ensure the exchange of information used to update and monitor the status of each component in the power generation, transmission and distribution systems. This information is later used in making decisions used for management, monitoring and control functionalities.

The physical layout of the ICT layer in the *Smart Energy System Laboratory* is shown on Fig. A.6. All computers and hardware components are connected via Gigabit Ethernet local area network (LAN) dedicated only for the laboratory giving the setup a high level of flexibility and room for controlled expansion. A detailed description of the core components is outlined as follows.

Cisco Catalyst 2960xseries Switch

In the middle core of the set up is Cisco Catalyst 2960xseries stackable layer 2 and layer 3 access switch. This device is chosen due to its ease of deployment, management and

troubleshooting. It is highly secure in that it uses standards based 802.1x for port based network access control, capable of scalable and dynamic role based access control with Cisco TrustSec and protects against IPV6 address theft attacks with IPV6 first hop security [20]. The Switch is configured with a separate VLAN on ports 2-48. Port 1, gigabyte Ethernet small form-factor pluggable (SFP+ 1) and SFP+ 2 are all set up as trunks meaning that all traffic on ports 2-48 will be routed through one of the trunks to the network server and not directly between ports.

Network Server

The network server is running Ubuntu Linux operating system which gives flexibility and serve for several purposes in the laboratory. It functions as a router providing Internet and NAT services for the local LAN. Moreover, it provides DHCP functionality, logs network traffic, provides NTP services, and serves as a network emulator for studying different communication technologies. The network emulator is designed to accommodate state-of-the-art network emulation and simulation platforms like KauNet, OMNeT++, OPNET and NS3. The Network Server provides additional functionality of using SSH for remote access and configuration of the whole setup.

Currently KauNet communication network emulation platform is configured on the system and elaborated in [18]. It is chosen because of its capability to perform network modeling with large degree of control and repeatability. It also gives the highly desired functionality of placing deterministic delay and packet loss patterns as well as precise control over bandwidth and delay changes [18] and [23].

CEMS Server

Customer Energy Management System (CEMS) server is dedicated for an application service that communicates with household devices for demand management systems. The platform was primarily implemented for *SmartC2Net* project as part of demand management control system to address situations where household consumption loads shift in timely manner [17]. This server is built with capability to configure one or many virtual CEMS machines and talk with the high layer demand response platform using the standard OpenADR protocol. It gives the system high degree of flexibility in that it mimics a platform with multiple virtual CEMS models in one machine and which appear as multiple independent CEMS devices to the upper layer demand management controller. CEMS runs optimization algorithm for customer energy management by using generic Gurobi optimization tool [21].

Virtual Smart Meter Server

Similar to CEMS server, virtual smart meter server is also designed and implemented as an integral part of European *SmartC2net* project platform intended for demand

management control functionality. It is developed to mimic multiple real smart meters and by using the standard Device Language Message Specification (DLMS) protocol to exchange information with *G-Smart*, an industrial data aggregation hardware developed by EFACEC[17]. For the aforementioned use case, *G-Smart* was used for demand management control HIL platform implementation. The virtual smart meter platform enables simulation based evaluation of different control and automation strategies to the demand response system.

Visualization Server

The graphics visualization server is used to facilitate automation of different smart grid applications implemented in the set up. It is previously used for on-line configuration of the network emulation server, where further information can be found in [18]. It is built to be flexible in a way that it can be utilized to model SCADA system for DSO voltage regulations, SCADA system for wind power plants and automation functionalities with GIS mapping.

A.2.4 Control Layer

The control layer has components to model and analyse demand response platform (DR, see Section A.3.2), automation and control of primary and secondary substations, medium voltage grid controller, low voltage grid controller and plant control unit. Implementation of models as well as controls is done using MATLAB/SIMULINK. It is modelled by using hierarchical control mechanism which offers the ability of decomposing the complexity into smaller sub-problems.

Hierarchical control structure, as shown in Fig. A.7, operates on several levels; the central management level, the medium voltage level, the low voltage level and the household level. This model breaks down the overall complexity of the system in to the hierarchies specified in the system.

For the structure of the electrical grid implemented, a control layer is added where some of the control is distributed throughout the distribution grid in contrast to the traditional centralized system. The medium voltage grid controller and low voltage grid controllers handle any voltage issues locally and provide flexibility at the same time to the upper layers Fig. A.7.

The functionalities shown in Fig. A.7 are executed on physical machines located on multiple locations, which requires communication to be able to receive inputs and send set points between each other. However, as different controllers have varying quality of service (QOS) requirements which is dependent on the communication technology used, ICT platform of *Smart Energy System Laboratory* is essential in emulating this technologies.

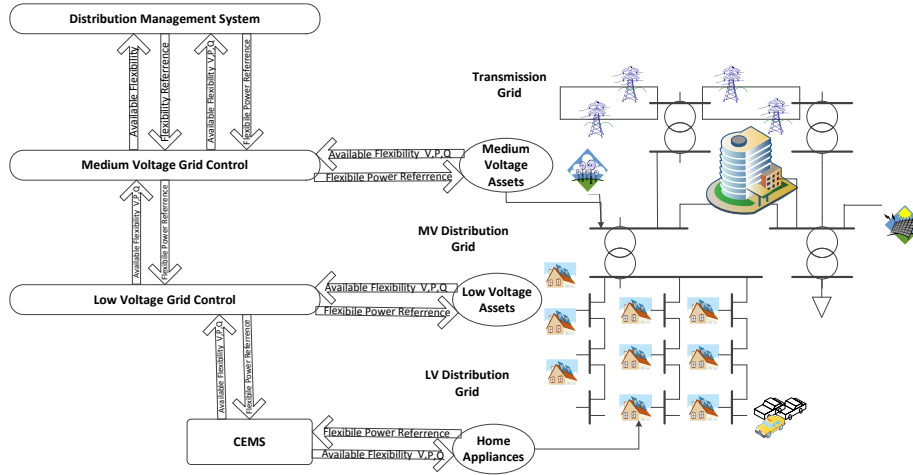

Fig. A.7: Implemented Hierarchical Control Model

A.3 Real Time Test Cases

To give us a better perspective of how *Smart Energy System Laboratory* can be employed to study Smart Grid applications involving ICT and real-time hardware in the loop platforms, the following test cases are presented.

A.3.1 Active Power Management in Distribution Grid Test Case

The functionalities validated in this test-case are:

- **Impact of Communication Technologies:** PLC, GPRS and LTE communication technologies are compared and the impact on the controller is studied. Real experimental traces for delay, packet loss, bandwidth and cross traffic is used to create a realistic real-time network emulation platform.
- **Energy Balancing:** It is shown that a distribution grid can be controlled to follow an active energy reference. The performance of the energy balancing is evaluated according to root mean square error of reference tracking [17].
- **Loss Minimization:** It is shown that active power losses in the MV grid can be reduced by making use of the medium voltage controller.

Active Power Management Test Result

To capture the full day disparity on consumption and production, each of the conducted tests has duration of 16 hours. For verification purposes, the MV grid is controlled to follow an active power reference. The controllable assets are used to compensate for the variations and follow the reference accordingly. The following scenarios are considered for the tests:

- Energy balancing with ideal communication (no loss introduced by the network emulator, Ethernet in the local LAN).
- Energy balancing with imperfect communication (PLC, Gprs, LTE technologies emulated).
- Energy balancing with imperfect communication and controller gain adaptation.

One result of the numerous test cases studied is shown in Fig. A.8 and A.9 compares the reference tracking ability for LVGC and MVGC by using ideal communication (only Ethernet LAN) and non ideal communication (PLC with 7kBps cross traffic). For the ideal case on LVGC, an average error of 4.5% is measured, while for the non ideal case the average error rises to 15.1%. From this, it is concluded that the tracking ability of LVGC tested with PLC with 7kBps is acceptable for power balancing control functionality satisfying requirement of the controller used for the experiment[17].

The MVGC reference following capacity has not been affected as the LVGC case because ideal communication is considered between LVGC and MVGC for this specific scenario. This shows the impact of PLC communication with 7kBps between LVGC controller and flexible assets has minimal impact on the higher layer MVGC. Further results of the remaining test cases are found at [17] and will be addressed on subsequent publications.

A.3.2 Demand Management Platform

Demand Management Test Case

Demand Management is a planning methodology that addresses the case of shifting electric consumptions in response to electricity prices by making use of proper scheduling mechanisms. *Smart Energy System Laboratory* is used to study realistic scenarios by implementing several standard protocols; Open Automated Demand Response (OpenADR), Device Language Message Specification (DLMS) protocol, and an industrial aggregator *Gsmart* (as seen in Fig. A.10); it shows the Demand/Response head-end system responsible to receive flexibility information from the customer energy management system (CEMS) that in combination with information from external factors (e.g. weather information, current market prices and more) is used by the Demand Response

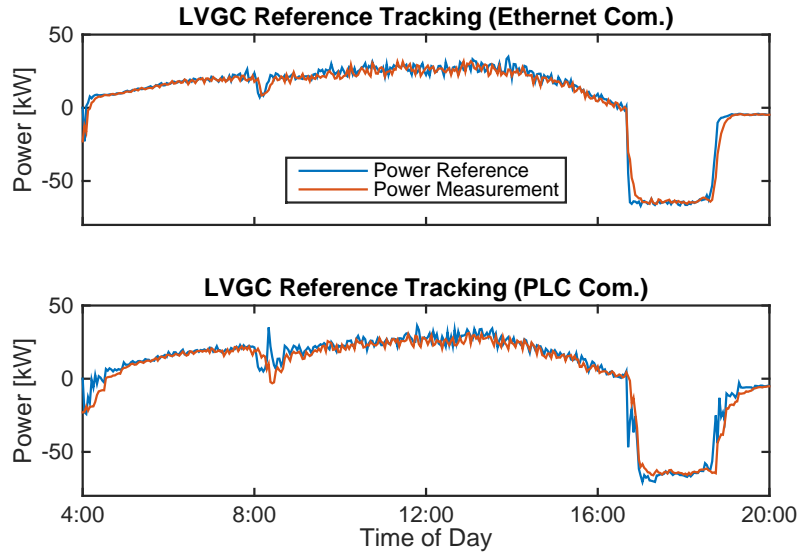

Fig. A.8: Reference tracking of low voltage grid.

platform to plan production and consumption for a longer time period. Set points are then calculated to be sent to the CEMS, which then enforces the values to the household [17].

The main components and protocols of the demand management system involved as shown in Fig. A.10 and their functionalities are described as follows:

- **Demand Management Control** : calculates demand energy reference for the available assets that can control the energy load, for example CEMS or Charging stations;
- **Head-end**: integrates systems from the back-end with the equipments on medium voltage and low voltage levels
- **Customer Energy Management System**: (CEMS), works as aggregator and controller for assets on a single household
- **Virtual Smart Meters**: Communicates with OPAL-RT grid model using UDP sockets (see Section 2.3)
- **G-Smart**: an industrial data aggregator from EFACEC used to accumulate load diagrams from virtual smart meters implemented at virtual smart meter server and by using the standard DLMS protocol

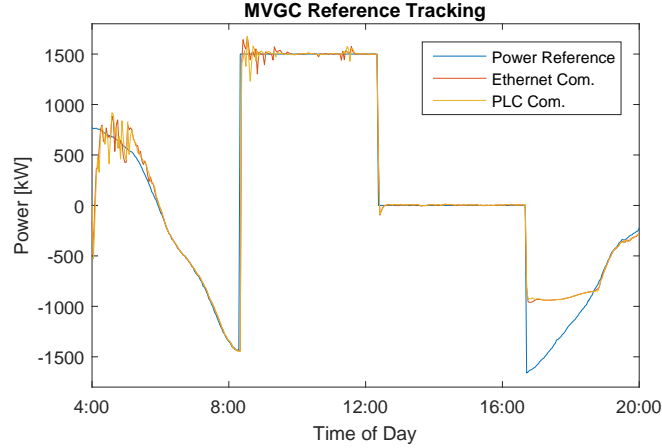

Fig. A.9: Reference tracking of Medium voltage grid

- **Open Automated Demand Response (OpenADR)**: is a standard protocol used to exchange information between CEMS and the Head-end system
- **Device Language Message Specification (DLMS)**: is communication standard modelling the communication entities between G-Smart and virtual smart meters

All CEMS controllers and their local asset models run on one CEMS server (see section A.2.3). The central DMC and the Head-end run on a dedicated machine on DSO control layer at *Smart Energy Systems Laboratory* (see Fig. A.11). The OpenADR protocol requires the definition of two additional client server pairs: the Virtual Tap Node (VTN) client & server and the virtual end node (VEN) client & server. In general clients have responsibility for sending messages, while the servers are responsible for listening and receiving messages (see Fig. A.11). At first the VTN sends a forecast of history data (background load, PV irradiation forecast and market clearing energy prices for that day). Periodical updates are initiated centrally by DMC once an hour. DMC collects the information at VTN database which also gathers the current updated information from CEMS served by VENReport. Once the data is collected the optimization loop is run over multiple iterations. Onwards, the computed setpoints are forwarded to VTN which then triggers VTNEvent for each VEN (household). The VENs call every 15 minutes to create reports and update the actuation values on CEMS.

The real-time HIL platform is used for validation of hybrid simulation-based evaluation implemented at FTW research center (a partner at *SmartC2Net* project). To fit with the hybrid simulation, a downscaled version of benchmark residential LV grid (see Fig. A.3 and Fig. A.4) is implemented where 38 households are connected to the low

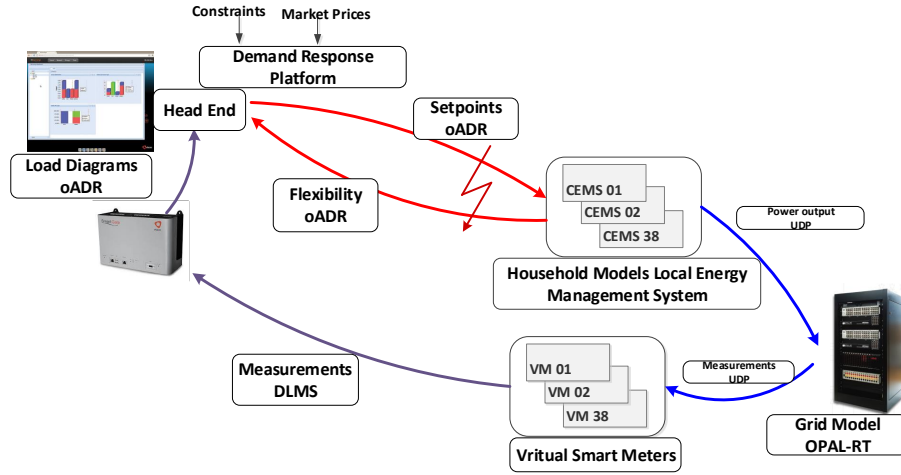

Fig. A.10: Demand Management Architecture

voltage grid. Real smart meter measurements are used to model the non-flexible load for each household. Each household is assumed to consume 5kW for heating, ventilation and air conditioning (HVACs). PV panels have a power rating of 4kW. Eight houses have electric vehicle charging points associated with various parking periods. The HVAC's initial indoor temperature is randomly distributed between 19.1 and 20.9°C, the outside temperature is assumed to be 1°C (January).

The experiments are performed in real-time, as CEMS setpoint consumption signals are sent to the real-time grid simulator which uses UDP sockets to get the values on the grid model at OPAL-RT. The virtual smart meters recreate metering information to be collected at the industrial aggregator G-Smart by using DLMS protocol and close the loop. Each test run is implemented for a span of 24+1 hours to get valid load profiles from smart meters for the full window a complete day.

Table A.1: Energy Cost Saving of Demand Response Platform [17]

Scenario	Baseline	DAP	DAP excessive demand
Total Energy/day	765KWh	1011KWh	1118KWh
Total Cost	33,75€	39,70€	48,25€
Resulting Avg. Price	44,23€/MWh	39,28€/MWh	43,15€/MWh
Savings	0	11%	2,5%

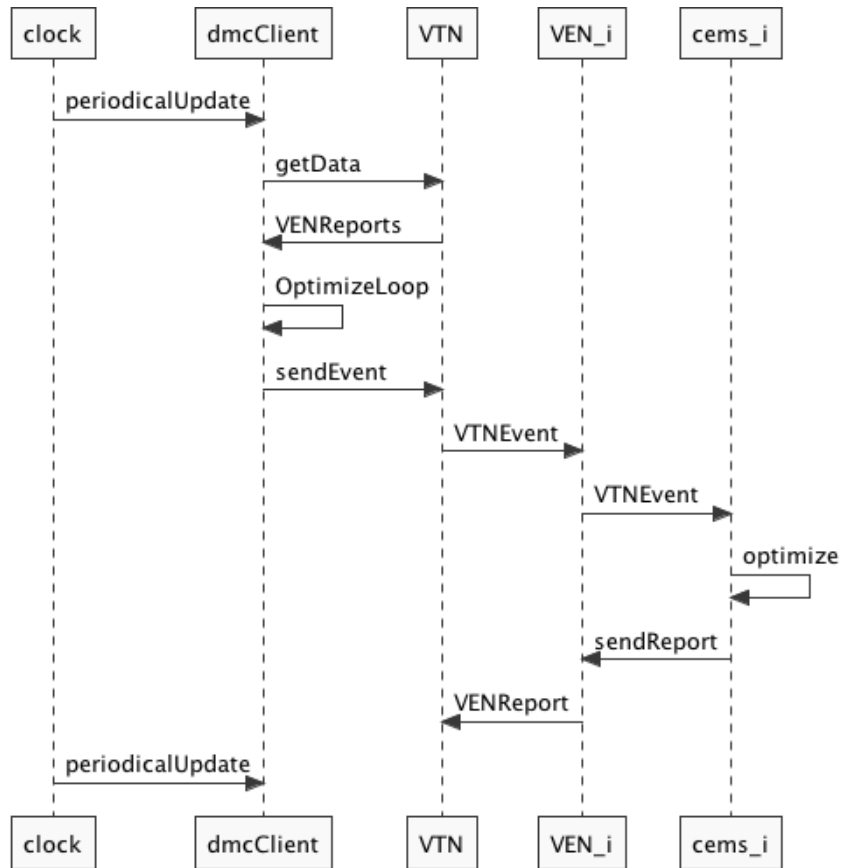

Fig. A.11: Interactions between the main DR components for CEMS [17]

Demand Management Test Result

To study energy cost saving by using the demand management platform; three scenarios are tested [17], with these specific test scenarios, the goal is to use local stored or produced energy internally when the price of electricity is expensive and to use more power from the grid when electricity price is low. The first scenario is tested as a measure of comparison (Baseline, fixed price and DMC in-active) for the remaining scenarios. Then the test scenario is repeated by using day ahead prices and DMC on, here an interesting correlation with the price value is observed. To study further extreme case, a scenario with day ahead prices and excessive demand on house holds is tested. Table A.1 shows the overall comparison of the three cases in-terms of Energy

cost saving.

Baseline with No DMC Control: CEMS is not getting set-points from the DMC instead assuming constant electricity price; the consumption and generation is independent of electricity prices for the whole time span. It is used as a baseline to compare and contrast improvements in energy cost saving when we turn on the DMC.

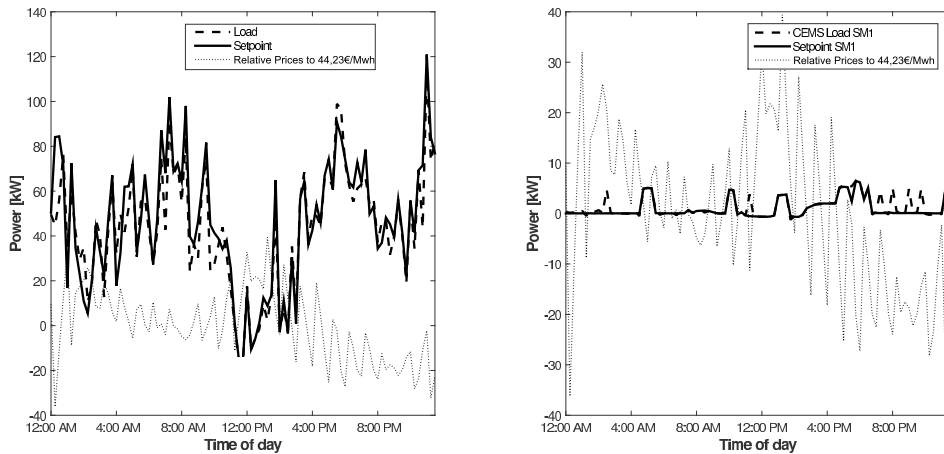

(a) DMC with day-ahead Price CEMS results

(b) Household CEMS Measurements

Fig. A.12

DMC with Day-ahead Prices Considered: DMC is sending setpoints to CEMS with day ahead electricity prices considered by the demand response platform. Fig. A.12a shows the results for the scenario DMC with day ahead prices (DAP) considered for CEMS on all 38 households. It shows the total load vs total setpoint of 38 houses (day ahead price considered), the load values are in 15 minute interval of the full 24 hours, 0 representing the time 00:00 [17]. Fig. A.12b also shows a measurement for one household. The price value is the relative increment or decrement from an average price of 44,236 €/Mwh. As seen in the figure, the demand response platform has mitigated impact of communication overhead created by using OpenADR, DLMS protocols and UDP communication with the OPAL-RT grid model; i.e on reference following capacity of CEMS. We can also see an significant correlation between the price value and the set points, where in case of low price the set points increase a bit in order to make use of the cheap electricity price from the DSO.

The energy cost saving capacity of the system has improved by 11% as seen in table A.1 when compared to the baseline scenario.

DMC with Day-ahead Prices and Excessive Demand: Overload is introduced

in to the system, which means, the DMC has to decrease demand limit (LVmax) to 70kw at the transformer. This has decreased the savings down to 2,5% but still households can benefit when compared to the baseline. The full set of results is documented in [17] and will be analyzed in great detail on subsequent publication.

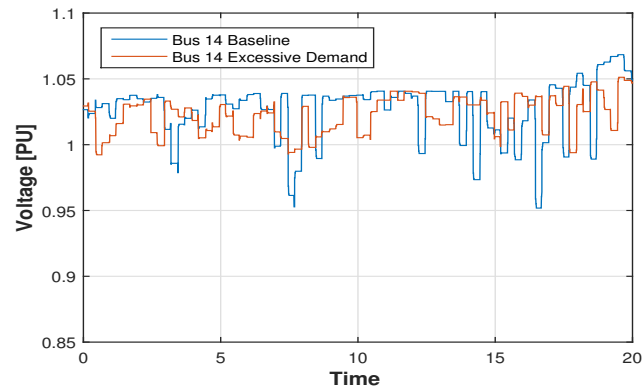

(a) Bus-14 Voltage Traces Baseline Vs Excessive Demand at Secondary Side of Transformer

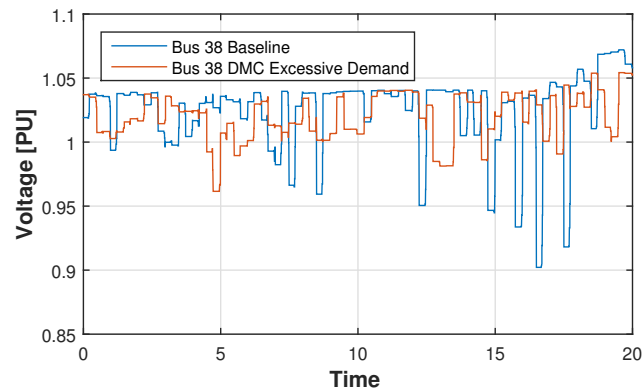

(b) Bus-38 Voltage Traces Baseline Vs Excessive Demand at Feeder end

Fig. A.13

Impact of Demand Management on Voltage Values: The presence of detailed power grid model on OPAL-RT has given us flexibility to study the impact of Demand Management system on voltage traces. Two scenarios are tested, Baseline scenario with

no connection to DMC and Excessive Demand with an Active-DMC set with a total power limit of PLVmax of 70KW. The scenarios are compared in Figs. A.13a and A.13b showing voltage traces of Bus 14 located at the secondary side of transformer and Bus 38 connected at Feeder end. Since the real-time simulations were executed on continuous dates with different start times; Out of 24+1 hour of real-time measurements, the plots show voltage traces of 20-hour measurements with perfect time alignments for both scenarios. It can be seen from the plots that due to the impact of PV generation in the LV grid, voltages often exceed the nominal voltage value. We can also see voltage drops down to 0.95pu of nominal from Bus 14 and even as low as to 0.9pu for bus 38 which is reasonable because it is located at feeder end.

To see the voltage improvement with DMC, Figs. A.14a and A.14b show the histogram plot of the voltage deviation index as normalized per unit voltage variation (see Eq. A.1 where V_{base} is the voltage for baseline scenario and V_{ED} is the voltage for excessive demand). A positive voltage deviation shows that the DMC is improving voltage profiles compared to the baseline scenario. The plots further show even for Excessive Demand scenario, the demand management system resulted in a better performance compared to the baseline scenario. Voltage deviation for Bus 14 at the secondary side of transformer goes as low as -0.1 where for the feeder end at bus 38 it goes even lower (-0.15) as it is located at feeder end.

$$V_{di} = \frac{V_{base} - V_{ED}}{V_{base}} \quad (\text{A.1})$$

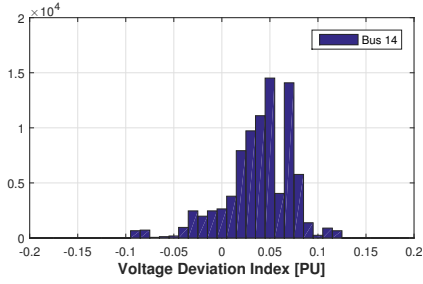

(a) Bus-14 Histogram of Voltage Deviation Index at Secondary Side of Transformer in Excessive Demand Scenario

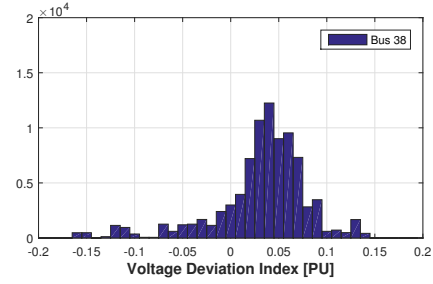

(b) Bus-38 Histogram of Voltage Deviation Index at Secondary Side of Transformer in Excessive Demand Scenario

Fig. A.14

A.4 Conclusion

This article provides a general overview of development of real-time open access platform towards proof of concept for smart grid applications at *Smart Energy System Laboratory* Laboratory of Aalborg University. The main components of the platform, namely physical domain comprising internal electrical grid and assets, the ICT layer, as well as the control layer are presented, and their interaction is highlighted. An innovative mechanism for setting and integrating of ICT and Network Emulation platform to real-time HIL smart grid laboratories is introduced. It is shown through the test case for Active Power Management in Distribution Grid how to investigate the impact of communication technologies on MV and LV controllers. The effect of communication Quality of service (QOS) parameters like delay, packet-loss, and bandwidth requirements can be studied in great detail by using the setup.

To show case how *Smart Energy System Laboratory* setup can be used to analyze current smart grid challenges; Active power management and Demand Management Platform implemented for European *Smartc2Net* project are presented. The article has shown practical implementation mechanisms taken to fulfill the vision of *Smart Energy System Laboratory* to capture key smart grid components and domains from energy markets down to individual smart assets in a real-time HIL framework.

References

- [1] H. Larsen, P. Erik Morthorst, H. Bindslev, and L. Sønderberg Petersen *The intelligent energy system for tomorrow*. WEC Montreal 2010, 12 – 16 September 2010
- [2] *Smart Energy System Laboratory*, [Online] Available: "<http://www.et.aau.dk/department/laboratory-facilities/smart-energy-systems-lab/>"
- [3] Christian Dufour and Jean Bélanger, *On the Use of Real-Time Simulation Technology in Smart Grid Research and Development*. IEEE transactions on industry applications : VOL. 50, NO. 6, November/December 2014.
- [4] Energinet Facts, [Online] Available: <http://energinet.dk/EN/El/Nyheder/Sider/Dansk-vindstroem-slaar-igen-rekord-42-procent.aspx>
- [5] R. Pederson, C. Sloth, G.B. Andersen, and R. Wisniewski, *DiSC: A Simulation Framework for Distribution System Voltage Control*. 2015 European Control Conference (ECC) : July 15-17, 2015. Linz, Austria.
- [6] M. Altin, A. D.Hansen, N. A.Cutululis, H. W.Bindner, F. Iov, and R. Olsen, *Ancillary Services from Renewable Power Plants- RePlan Project Perspective*. 14th

- International Workshop on Large-Scale Integration of Wind Power into Power Systems as well as on Transmission Networks for Offshore Wind Power Plants no. 4, pp., 20-22 October 2015.
- [7] P. Chen, R. Salcedo, Q. Zhu, F. de Leon, D. Czarkowski, Z. Jiang, V. Spitsa, Z. Zabar, and R. Uosef, *Analysis of voltage profile problems due to the penetration of distributed generation in low-voltage secondary distribution networks*, IEEE Transactions on Power Delivery : no. 4, pp. 2020 – 2028, Sept. 2012.
- [8] J. Østergaard, Q. Wu, and R. Garcia-Valle, *Real Time Intelligent Control Laboratory (RT-ICL) of PowerLabDK for Smart Grid Technology Development*. IEEE Complexity in Engineering (COMPENG) : 11-13 June 2012. Aachen, Germany.
- [9] Deliverable 6.3, *SmartC2Net - Smart Control of Energy Distribution Grids over Heterogeneous Communication Networks.*, November 2015, Aalborg, Denmark.
- [10] DiSC-A Simulation Framework for Distribution System Voltage Control, 2014, [Online]. Available:<http://kom.aau.dk/project/SmartGridControl/DiSC/>
- [11] M. S. Kemal, R. Pedersen, F. Iov and R. Olsen *DiSC-OPAL: A Simulation Framework For Real-time Assessment of Distribution Grids*. Workshop on Modeling and Simulation of Cyber-Physical Energy Systems, CPS Week 2017.
- [12] F. D. Bianchi, H. de Battista, and R. J. Mantz *Wind Turbine Control Systems: Principles, Modelling and Gain Scheduling Design*. Advances in Industrial Control : Springer, 2007.
- [13] I. V. der Hoven *Power spectrum of horizontal wind speed spectrum in the frequency range from 0.0007 to 900 cycles per hour*. Journal of Meteorology : vol. 14, pp. 160–164, April 1957
- [14] M. G. Villalva, J. R. Gazoli, and E. R. Filho *Comprehensive approach to modeling and simulation of photovoltaic arrays*. IEEE Transactions on Power Electronics : vol. 24, no. 5, pp. 1198–1208, May 2009.
- [15] M. K. Deshmukh and S. S. Deshmukh, *Modeling of hybrid renewable energy systems.* Renewable and Sustainable Energy Reviews: vol. 12, no. 1, pp. 235 – 249, 2008.
- [16] National travel survey Department for Transport, Tech. Rep., 2012. [Online]. Available: <https://www.gov.uk/government/publications/national-travel-survey-2012>
- [17] P. Kundur *Power System Stability and Control.* The EPRI Power System Engineering Series. McGraw-Hill, 1993.

- [18] M. Kemal, F. Iov, R. Olsen, T. Le Fevre, and C. Apostolopoulos, *On-line Configuration of Network Emulator for Intelligent Energy System Testbed Applications 2015* IEEE AFricon : 14-17 Sep, 2015. PP 1-4, Addis Ababa, Ethiopia.
- [19] J. Garcia, P. Hurtig, and A. Brunstrom *A Versatile and Flexible Emulation System 2015* Swedish National Computer Networking Workshop (SNCNW08) :2008, Sweden.
- [20] Cisco Catalyst 2960xseries Switch [Online]. Available: <http://Cisco.com>
- [21] Sandford Bessler, Mohammed Seifu Kemal, Nuno Silva, Rasmus Olsen, Florin Iov, Domagoj Drenjanac, Hans-Peter Schwefel *Grid-Aware Demand Management in Electricity Distribution Grids*. Sustainable Energy, Grids and Networks [Submitted for publication], 2017.
- [22] *Smart Control of Energy Distribution Grids over Heterogeneous Communication Networks*, [Online], Available:"<http://www.smartc2net.eu/>".

Paper B

On-line Configuration of Network Emulator for Intelligent Energy System Testbed Applications

Mohammed Seifu Kemal, Florin Iov, Rasmus Løvenstein Olsen, Thomas
le Fevre Kristensen and Christos Apostolopoulos

The paper has been published in the
IEEE AFRICON 2015, 2015.

The layout has been revised.

Abstract

Intelligent energy networks (or Smart Grids) provide efficient solutions for a grid integrated with near-real-time communication technologies between various grid assets in power generation, transmission and distribution systems. The design of a communication network associated with intelligent power system involves detailed analysis of its communication requirements, a proposal of the appropriate protocol architecture, the choice of appropriate communication technologies for each case study, and a means to support heterogeneous communication technology management system. This paper discusses a mechanism for on-line configuration and monitoring of heterogeneous communication technologies implemented at smart energy system testbed of Aalborg university. It proposes a model with three main components, a network emulator used to emulate the communication scenarios using KauNet, graphical user interface for visualizing, configuring and monitoring of the emulated scenarios and a network socket linking the graphic server and network emulation server on-line. Specifically, our focus area is to build a model that gives us ability to look at some of the challenges on implementing inter-operable and resilient Smart Grid networks and how the current state of the art communication technologies are employed for smart control of energy distribution grids.

B.1 Introduction

In our current world with intelligent energy systems, coupling major energy generation sectors with renewable and non-renewable sources is considered as a key to promote clean energy and improve efficiency and costs. Various researches are being done for a cost-effective solution incorporating existing and future communication networks of both energy and telecommunication providers, enabling exchange of data among end-users, power generating facilities and operators, and offering open service platform for implementation of the advanced grid monitoring and control functionalities [1].

However, there is limited availability of smart energy installations or real-time systems to test the standards being developed, address the resulting issues and to justify worth of using the technology. Hence smart energy systems testbed at Aalborg University is built as part of SmartC2Net EU project with the goal to develop, implement, and validate robust solutions that enables smart grid operation on top of heterogeneous communication infrastructures [3].

By making use of the testbed, the main focus for this work is a mechanism that enables detailed analysis of communication QoS requirements, choice of appropriate communication technologies for specific use cases and integrating heterogeneous communication technologies for intelligent energy network emulation.

B.2 Related Works

In relation to designing heterogeneous communication network for smart grid implementation, [4] is focused on proposing a heterogeneous communication paradigm for smart grids based on power line communications and wireless networks. The proposal is related to the framework of the ITU (International Telecommunication Union) ubiquitous sensor network architecture using the ITU next-generation network model. The article argues that this architecture allows for better management of the QoS in the smart grid and should facilitate interoperability with other technologies.

[5] discusses some of the challenges and opportunities of communications research in the areas of smart grid and smart metering. In particular, focus is given on some of the key communications challenges for realizing inter-operable and future proof smart grid/metering networks, smart grid security and privacy, and how some of the existing networking technologies can be applied to energy management.

As for standards regarding QoS parameters, [6] states the communication delivery times for different applications in smart grids. It has described a standard defining communication delivery times of information to be exchanged within and external to substation integrated protection, control, and data acquisition systems [6]. Our paper here differs from other literature's because it proposes a method for on-line configuration of heterogeneous communication technologies for a test-bed implementation and using the network emulation platform KauNet.

B.3 Smart Energy Systems Laboratory

Smart energy system setup shown in Fig. B.1 is a testbed built with the vision to capture key components and domains from energy markets down to individual smart assets in a real-time hardware in the loop framework and facilitate a platform to design, build and test the proposed new technologies [3].

It is of great aid for analysis of adaptive network and grid monitoring, strategies to control communication network configurations and QoS parameters, and extended information models and adaptive information management procedures. It is built to support three key sectors in intelligent power systems, the communication layer, control layer, and power system assets [7].

B.3.1 Communication Layer

The communication layer has traffic generator, network emulator and visualization server (shown in Fig. B.1). The traffic generator is built with capabilities to support platforms such as Scapy and TCPRelay. The network emulator is built to support state of the art network emulation and simulation tools like Dummynet, Kaunet, OMNeT++

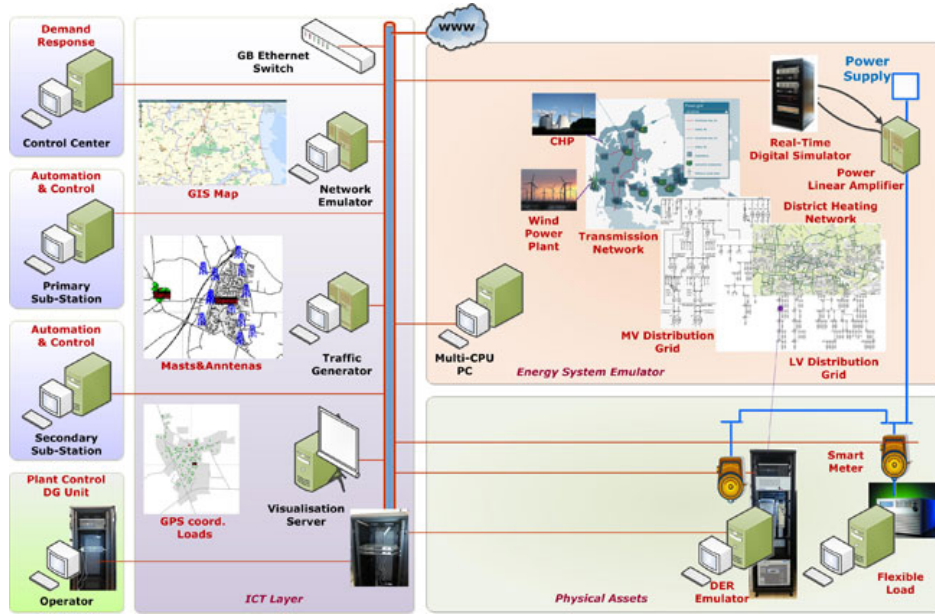

Fig. B.1: Overview architecture for Smart Energy Systems Laboratory Setup [3]

and NS-3. For the system proposed here, KauNet is used to emulate and model the communication infrastructure.

Kaunet Overview

KauNet is an add-on to the well-known Dummynet network emulation software. KauNet extends Dummynet by providing deterministic emulation capabilities [8]. Hence, It enables a higher control of the emulated network. The major reason why KauNet is used for modeling the emulation system is because it provides capability to perform network modeling with large degree of control and repeatability. It allows deterministic placement of packet losses as well as more precise control over bandwidth and delay changes.

Patterns are used to provide advanced control of per-packet, or per-millisecond, control over the emulated network model. To create patterns, we can use three types of input mechanisms, by using input data from analytical expressions, from practical experimental tests and from simulated tests. For example, experimental test results for GPRS, LTE and ADSL communication technologies are built by using this model.

Currently, the following five types of patterns are supported by the proposed model:

- packet loss patterns
- bit-error patterns
- bandwidth change patterns
- delay change patterns
- packet reordering patterns

B.3.2 Control Layers

The model implemented in the control layer has components to model and analyze, demand response platform(DR), automation and control for primary and secondary substation, medium voltage grid controller, low voltage grid controller and power control for distributed generation unit. Implementation of models as well as controls is done using MATLAB/ SIMULINK [7]. This system is receiving set-points from hierarchical control structure.

B.3.3 Power System Assets

The power system simulator is using real time energy system emulator where it consists of two elements namely the Real-Time Digital Simulator and Power Linear Amplifier. The assets supported by the emulator are a generic dispersed energy resource with wind, PV and battery connected through Smart Meter, a flexible load where a 4.5 kW controllable AC/DC load is used to mimic the behavior of loads in a typical household.

B.3.4 Online Configuration of Network Emulator Overview

The system is modeled with ability to visualize the whole communication system online where a graphic server is used to monitor and configure the telecommunication infrastructure modeled using the network emulator. It will help the emulation platform monitor the condition/impact of communication technologies used on our testbed. This model can be used to study the following three scenarios in detail.

Homogeneous Communication Environment

One communication technology is used for the whole system. To give an example, all smart meters, data aggregators and controllers are connected using Ethernet technology. Such scenarios may be obtained in new and completely projected installations.

Heterogeneous Communication Environment

The components on the power grid share a mix of different communication technologies. An example can be given where multiple smart meters via GPRS, other smart meters are utilizing LTE, Aggregators communicating using ADSL. This environment may be a case when a single communication technology cannot be deployed.

Multiple Communication-Interface Environment

Each component may have the ability to use more than one communication technology using multiple interface. To give an example, a scenario can be considered where smart meter can choose between LTE and ADSL depending on the condition of the communication link.

B.4 System Model

On-line configuration model implemented at smart energy systems testbed is depicted by Fig. B.2. It incorporates the graphic server used as the graphical user interface in order to visualize, monitor and configure the emulated scenarios. The emulation server is set to emulate the communication infrastructure using KauNet on a pattern generated from real experimental tests. The two systems are connected using UDP network sockets implemented on both the graphic server and the network emulation server.

B.4.1 Visualization Interface

The Google Maps API [10] which allows geometrical shapes (such as circles, rectangles, polylines, and pop up windows) to be overlaid on the standard maps provided by Google is used for the UI (User Interface) in order to visualize and configure the assets, voltage controllers and the connection between them. Even though this API is implemented in JavaScript, a wrapper that allows this to be accessed in Java is used for more robust data transfer and calculations [11]. An example of the UI implemented can be seen in Fig. B.3.

Assets are drawn as rectangles of varying colors where voltage controllers are drawn as standard circles. Colors indicate QoS levels for connections used by the particular asset. Each asset is colored with respect to its average quality based on the connections that it is consisted of (shown by the polylines connected).

From the UI it is also possible to send data back to the network emulator. Specifically, by clicking on a polyline we can change the current connection of an asset (e.g. from LTE to GPRS). In this way it is easy to re-configure the technologies that the assets use in the case where low quality connections exist.

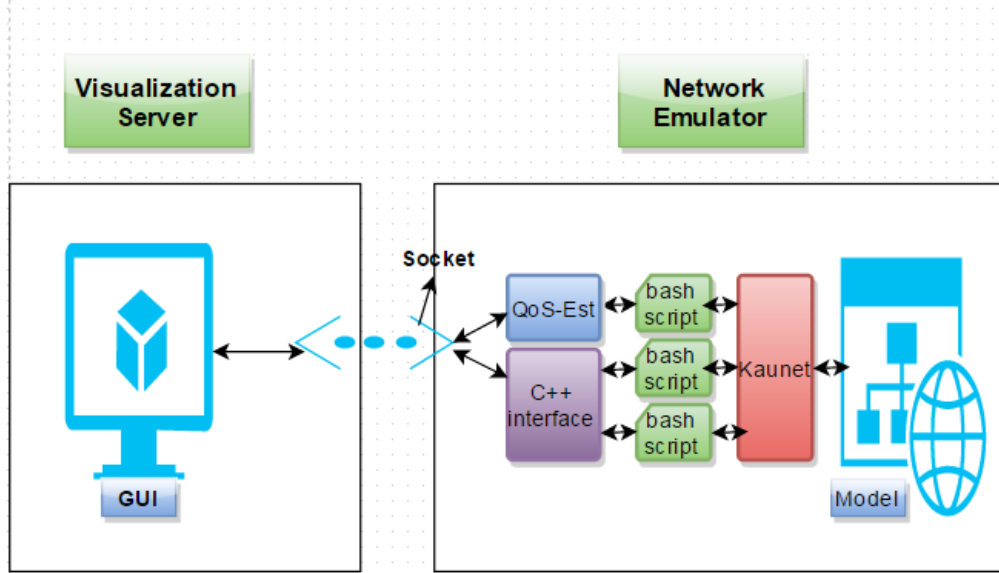

Fig. B.2: System Model for On-line Configuration of the Network Emulator

Database

The way the data for visualization is retrieved is from a local database which is stored on the graphics server. It is formatted in a text file and its structure can be seen in Table B.1:

Table B.1: Entry of Database that is consisted of an asset with two connections

1,	56.909777,	9.913101,	3,	green,	5,	green,
----	------------	-----------	----	--------	----	--------

An entry is sorted in the following order: ID, latitude, longitude, connections. Each connection is defined by its ID following the color denoting the QoS level.

B.4.2 Kaunet Configuration

Network Emulation

Network emulation is commonly used to evaluate and examine the behavior and performance of applications and transport layer protocols [8]. Its advantageous over simulations in that we can use wide range of real implementations of protocols and applications while testing the scenarios.

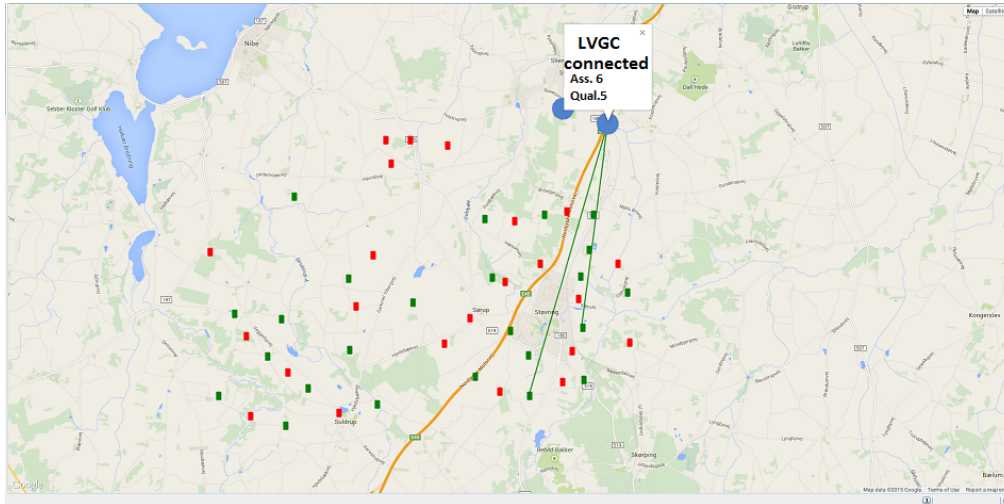

Fig. B.3: Screen Shot the Visualiation Interface Showing Assets and Communication Links

Figure B.4 is a schematic model description of the processing performed by KauNet queues. Pipes made of the three types of queues are used to generate introduce traffic delays, packet losses and changing other parameters. To elaborate more on the three types of queues and how they are used to change the parameters:

The queues denoted by \mathbf{q} are reception queues, or bandwidth queues. Packets coming from the network are put on wait for some time span, a delay equal to the transmission time for the emulated communication link. When the arriving traffic rate is higher than the bandwidth on the emulated communication link, the queues will add up introducing queuing delay on top of transmission time delay. During the occasion of overflowing, the queuing scheme used will determine on how the packets are dropped. The size of \mathbf{q} is configurable according to the scenarios used and has a default value of 100.

The second type of queue as shown by the schematics \mathbf{p} is a delay line queue where packets are made to wait for a period specified by the emulated delay pattern file to that corresponding packet.

The third type of queue is reordering queue \mathbf{r} , It is used by KauNet as per the information set on the pattern file. It has a simple mechanism where it holds the packets selected for reordering before it is put in the delay line queue. Packets not chosen for reordering bypass this queue completely.

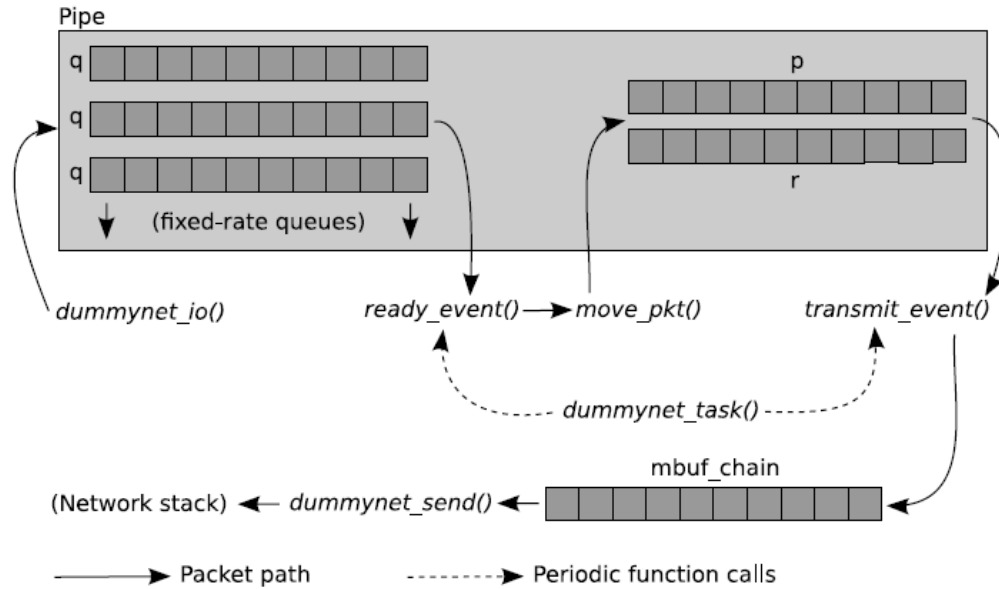

Fig. B.4: KauNet Pipe Used for Modeling QoS Parameters by Network Emulator[9]

B.4.3 Network Sockets

The connection between the Network emulator and the graphics server is implemented with a UDP socket. This is mainly due to the need of a continuous stream of data in order to retrieve information and update the graphics server in real time, since the network patterns can change dramatically over time.

For this, we are proposing C++ interface configuring scripts using a feature of Bash that allows a programmer to send and retrieve data from a device socket that we can build. This is especially handy because we have a service running on our system that is listening for data on a port, and a shell script that handles setting the parameters for KauNet pipes.

B.4.4 Network Emulation Configuration

To understand the process, let us go through steps taken to set up the whole system. During Initialization phase, the original structure of the network is located in the graphics server. Therefore, all the information regarding the assets is sent to the network emulator via the C++ interface used by calling the corresponding bash scripts used to set up the network emulator. The network emulator and the graphics server

need to use the same identification code. The most important information that is sent is the ID and link configurations of each asset, which will be used for adjusting the emulated communication technologies.

The next phase is sending network parameter Information from the network emulator to the graphics server. The medium that converts the emulations into the graphics server's format is the QoS estimator(see Fig. B.2).

After getting information regarding quality of each link, through the UI, connections can be configured in case when one technology does not provide the required QoS parameters. As seen in Fig. B.3, this change can be made by clicking on a connection and choosing the desired technology. The network emulator is then notified and creates a new network emulation which will be visualized by the GUI.

B.5 Conclusion

This article provides a general but complete view of how on-line configuration of network emulation can be modeled and implemented for intelligent power system setups. In essence, smart energy testbeds are built to support and incorporate different layers on the current smart grid systems. This proposal has shown heterogeneous communication infrastructures can be supported by using network emulation tools, in our case KauNet. On-line monitoring and configuration platform is also proposed by using visualization server and configuration interfaces to facilitate exchange of status details on the fly.

The major advantage of this set up is, effect of communication QoS parameters on multiple control layer applications can be tested on-line. Furthermore, a number of power system assets can be connected and studied. This will be very useful for making detailed analysis of its communication requirements, proposal and tests of appropriate protocol architecture and the choice of appropriate communication technologies for different case studies.

References

- [1] *Sustainable and robust networking for smart electricity distribution*, <http://sunseed-fp7.eu/publications/> 2014.
- [2] *Smart Control of Energy Distribution Grids over Heterogeneous Communication Networks*, [http:// www.smartc2net.eu](http://www.smartc2net.eu)
- [3] *Smart Energy Systems Lab*, <http://www.et.aau.dk/department/laboratory-facilities/smart-energy-systems-lab/>. 2014.

- [4] A. Zaballos, A. Vallejo, and J. Selga, University Ramon Llull *Heterogeneous Communication Architecture for the Smart Grid*, 3rd ed. IEEE Network • September/October 2011
- [5] Z. Fan, P. Kulkarni, S. Gormus, C. Efthymiou, G. Kalogridis, M. Sooriyabandara, Z. Zhu, S. Lambotharan, and W. Hau Chin *Smart Grid Communications: Overview of Research Challenges, Solutions, and Standardization Activities*, . IEEE Communications Surveys and Tutorials 2011
- [6] 1646TM IEEE Standard Communication Delivery Time Performance Requirements for Electric Power Substation Automation, 2004, IEEE Power Engineering Society,
- [7] C. Cioneta, R. P,T. Kristensen, C. Sloth, R. Olsen ,F. Iov *Smart Grid Control and Communication: the SmartC2net Real-Time HIL Approach*, POWERTECH EINDHOVEN, 2015.
- [8] Johan Garcia, Per Hurtig, and Anna Brunstrom., *KauNet: A Versatile and Flexible Emulation System*, . In Proceedings of the 5th Swedish National Computer Networking Workshop (SNCNW2008)
- [9] J. Garcia, P. Hurtig, A. Brunstrom, T. Hal *KauNet 2.0: Design and Usage*, Karlstad University, 2012
- [10] *Google Maps API*, <https://developers.google.com/maps/> 2014.
- [11] *GmapsFX* , <http://rterp.github.io/GMapsFX/> 2014.

Paper C

Information Quality Aware Data Collection for Adaptive Monitoring of Distribution Grids

Mohammed S. Kemal, Rasmus L. Olsen and Hans-Peter Schwefel

The paper has been published in the
*SGIoT: The 1st EAI International Conference on Smart Grid Assisted Internet of
Things*, 2017.

The layout has been revised.

Abstract

Information from existing smart metering infrastructure, which are currently mainly used for billing purposes, can also be utilized to monitor and control state of the grid. To add functionalities such as fault detection and real-time state estimation, data from smart meters should be accessed with increased frequency during run time. The data collection system should adapt to changing dynamics of the communication network and electrical grid. This paper first introduces adaptation functionalities for the data collection mechanism. To study and analyze the influence of configuration parameters that can be utilized for adaptation, a two-layer smart meter data access infrastructure is presented. An information quality metric, Mismatch Probability ($mmPr$) is introduced for the quantitative analysis of the two-layer data access system implemented in MATLAB based discrete event simulation study.

C.1 Introduction

In recent years, various initiatives have been proposed to standardize the communication to smart meter units. Examples of standardization and initiatives include, IEC 62056-58, IEC 62056-62 data exchange for meter reading, tariff and load control [5] [6], Device Language Message Specification DLMS/COSEM protocol [7], and communication system for meters and remote reading of meters [8]. The standardizations have opened the door for a better system integration of smart metering infrastructures for applications such as Demand Response and Home Energy Management Systems [9].

Regarding monitoring and automation of electric distribution systems, reference [10] presents a mechanism that utilizes smart metering infrastructure using GSM technology. The developed model is tested using two-way communication for remote control of supply and outage management along with automatic meter switching-off on the occurrence of a fault. References [11] and [12] propose a detailed examination of active and non-active power components by making use of modern smart meters for studying power quality, load monitoring and active power factor correction.

Adaptivity of network QoS and information access configurations is studied in great detail in the context of the SmartC2Net project [13], with the primary goal of enabling Smart Grid operations over imperfect, heterogeneous general purpose networks. References [14] and [15] studied an Information-Quality based low voltage (LV) grid monitoring framework and its application to power quality control. Reference [16] discusses utilizing network QoS for adaptive Smart Grid control with a focus on the influence of imperfect network conditions on Smart Grid controllers, and how this can be counteracted by utilizing Quality of Service (QoS) information from the communication network.

The approach proposed in this paper for monitoring of the electrical grid by adaptive

data collection methods is focusing on using smart metering infrastructures with an adaptation of access rates on metering data. Currently, most of the smart meters deployed in Denmark are used for billing purposes with meter readings at slow update rates [26]. The main contribution of this work is to investigate scenarios of access to smart meter data with short time granularity; specifically, the paper evaluates the impact of configurations of access procedures and the influence on the quality of smart meter data for varying communication delays and different scenarios of smart meter data variability. The overall concept of adaptivity is outlined in reference [4], here we go beyond this concept by adding the quantitative analysis of a two layer architecture and analyze dependencies between configuration parameters that can be adapted to the data collection system.

C.2 Adaptation Functionalities

For applications such as grid fault detection and real-time state estimation, the smart meter data is used in real-time with different time-horizons [22]. The update interval varies accordingly ranging from few seconds for grid-state estimation to few minutes for fault-localization. The actual measurement and data transmission frequency of the individual smart meters may, however, depend on various factors, and this paper will analyze benefits of adapting this measurement update frequency during run-time. The following basic adaptation scenarios can be distinguished:

Adaptivity to Changing Grid Dynamics: For an environment with high penetration of unpredictable, shifting solar PV units and storage devices in households where the state of assets changes fast, the grid is susceptible to short time power variations of distributed generations. To give an example, during partially cloudy conditions, PV generation can fluctuate as fast as within a few seconds, influencing part of the LV grid behaviour with similar fast dynamics. If the data collection mechanism can adapt to the changing dynamics of the condition or process, reliable operation can be ensured within the communication constraints. Adapting update rates at smart meters accordingly would give us an improved observability of the distribution grid. However, this occurs at the cost of increased network load, which is addressed in the next paragraph.

Adaptivity to Changing Communication Network Dynamics: A communication network is one of the core parts of the smart metering data collection scheme. It is also inherent that for both wired (e.g., copper cable, fiber optic cable, and power line carrier) and wireless communications (e.g., cellular, satellite, microwave, and WiMAX), the communication network is variable and changing continually. For example, if the communication medium is shared with other users (e.g., GSM, 3G, shared PLC), the impact of cross traffic has an effect and changes performance of the whole system cre-

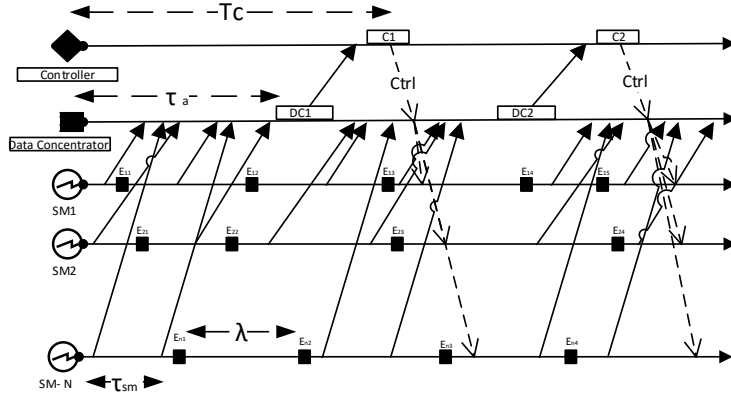

Fig. C.1: Two Level Smart Meter Data Access Infrastructure

ating increased delays, packet losses and low throughput. The data collection scheme should be adaptive to this variability to facilitate grid monitoring functionalities [2]. A two layer architecture is modelled to study and analyse dependencies between the configuration parameters that can be adapted to both changing dynamics of the grid and communication network which will be described in the following section.

C.3 Analysis of Two Level Smart Meter Data Access Infrastructure

Smart meter data is typically accessed via concentrators that store, aggregate, and forward information from multiple meters. That way, a two-level access structure is resulting which is illustrated in Fig. C.1 and further described and analysed as follows.

C.3.1 System Description

This section gives an abstracted description of the two level smart meter data access infrastructure (message sequence diagram shown in Fig. C.1). The two level data access infrastructure contains the following parts:

Change Event Process E_{ij} : The smart meter has capability to access a local measurand (typically power or voltage), which changes value over time. We consider a dis-

cretized value space, where only changes beyond a certain discretization threshold are considered. In this discretized setting, we call the time instances $E_{ij}, j = 1, 2, \dots$ when the measurand changes value the 'change event process' at Smart Meter $i, i=1, \dots, N$. We use the same parameter λ as rate of this change event process for all N smart meters.

Smart Meter Update Rate τ_{sm} : Each smart meter takes a measurement and sends it to the data concentrator with rate τ_{sm} , which we call smart meter update rate.

Concentrator Update Rate τ_a : Similarly the data concentrator sends its current view on the smart meter measurands to the control layer with an update rate of τ_a .

Control Action Time C_k : represent the moments where the controller takes action based on the available information of the smart meter values. We assume here that the time between control actions is deterministic with value T_C .

Communication Delays ν_{sm} and ν_a : Communication between each layer is represented by stochastically varying delays with mean values ν_{sm} and ν_a . The communication network is assumed to be reliable by utilizing retransmissions to compensate for losses. The downstream communication from the controller depicted by the dashed arrow is not taken into consideration for the analysis implemented in this paper.

C.3.2 Simulation Model and Metrics

In order to analyze the two-level smart meter data access strategy, we use a stochastic discrete event simulation realized in Matlab. For the simulation studies, the information element at each smart meter is maintained by each smart metering node and dynamically changes its value at certain points with a poisson process. We also make the assumption that the information change is always resulting in a new value not observed previously. The time between information updates is exponentially distributed with rate τ_{sm} and τ_a . A Poisson process is chosen because the focus and interest on this paper is for cases where smart meters send updates with some variability, modelled by a stochastic process. The parameter space is simplified by using a poisson process which also gives us flexibility to perform further mathematical analysis, which for now is beyond the scope of this paper. The default assumption for the communication infrastructure is a static network model where the mean values ν_{sm} and ν_a are assumed to be constant. Later in Section 3.4, this assumption is however modified in order to capture also the impact of the smart metering traffic on the communication network performance. Smart meter and data concentration layers are considered to be symmetric by utilizing the same communication network where $\nu_{sm}=\nu_a$.

To study a PLC communication scenario where congested and non congested PLC (with cross traffic) links are used for the two layer data access scenario, mean communication delays of 5s and 250ms are set respectively (static network assumption). The choices are motivated based on experimental studies also presented by [25]. For analysis of fast changing information elements at the smart meters $\lambda = 10s$ is derived for a normal household based on statistical studies for residential load modelling done by [24]. The control interval T_c for all the tests is 2.5s motivated by a microgrid control scenario in [25]. All the simulation results presented in this paper are for simulation time of 1000s for each update rate combinations.

The motivation for the smart meter data access is a control scenario as for instance analyzed in [25] for a power balancing controller. However, this paper will stay independent of the specific controller realization and therefore uses information quality metric, which has first been introduced in [21]: The mismatch probability (mmPr) is the probability that the information at the controller, during the time of control execution C_i does not match within the discretization thresholds with the true measurand value at the smart meter at that instance (see Equation C.1). This is under the hypothesis that a correct and timely information leads to expected control performance, while mismatching information degrades the control performance. The advantage of mmPr as metric is that it combines in a single scalar the impact of update rate choices and network delays and puts those in relation to the dynamics of the grid scenario (measurand at the smart meter). The metric has been successfully applied to optimize Smart Grid control in [14] and [15]. Equation C.1 shows mmPr calculation for a smart meter, where $info_{controller}$ denotes the controller's view on the Smart Meter information and $info_{SM}$ denotes the actual value of the measurand at the smart meter; both are considered at actuation moments C_k .

$$mmPr = Pr(info_{controller}(C_k) \neq info_{SM}(C_k)), \quad (C.1)$$

C.3.3 Quantitative Analysis of Smart Meter Update Rates Over Static Delay Model

In this paper, we are mainly interested in the impact of the update rate of the smart meters and of the concentrator on the resulting information quality at the control instances. We therefore vary these update rates in the ranges $0/s$ to $2/s$ and $1/\lambda$ of 10s. Figure C.2 shows a 3D plot of the resulting mmPr values for varying τ_{sm} and τ_a by using non congested PLC communication. As clearly seen in the relationship, when any of the update rates go to a zero value the mmPr values approaches to 1 which is clear as less update maps to less knowledge of the current state of the meter (higher mismatch).

A different 2D visualization of the same simulation results in Fig. C.3a shows the τ -combinations that lead to different levels of mmPr, e.g. any (τ_{sm} and τ_a) combination

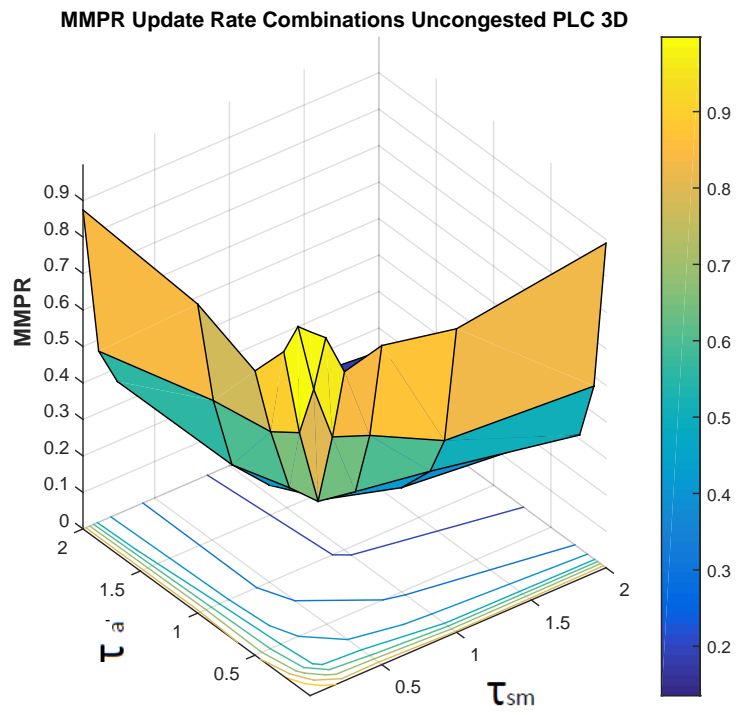
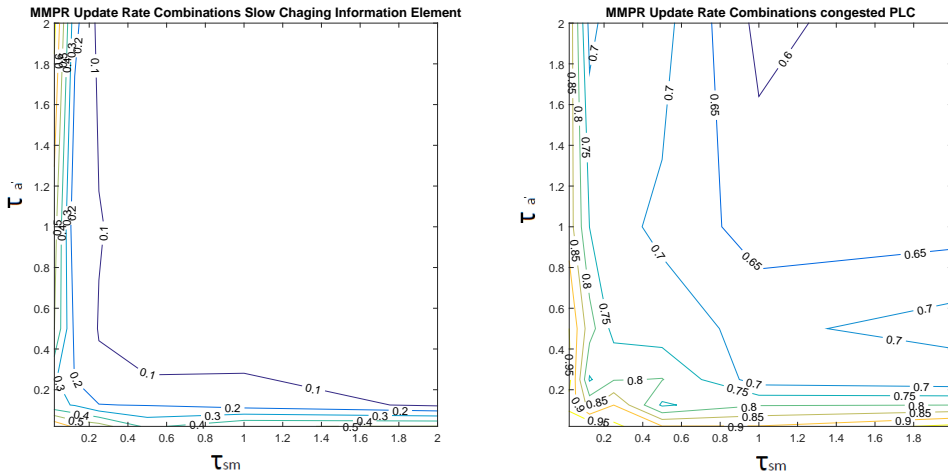

Fig. C.2: Update Rate Combinations to fulfil mmPR requirement bounds for non congested PLC scenario 3D



(a) Update Rate Combinations to fulfil mmPR requirement bounds for non congested PLC scenario (b) Update Rate Combinations to fulfil mmPR requirement bounds for congested PLC scenario

Fig. C.3

above and to the right of the blue line with $mmPr=0.2$ would perform better than that $mmPr$ threshold. It can also be seen in the result that updating τ_a may not necessarily change the $mmPr$ value on the left top section of the plot, if τ_{sm} stays constant. A similar observation holds for large τ_{sm} in the lower right part of the graph.

Figures C.3a and C.3b show the contrast between the congested and non-congested PLC scenarios. Figure C.3b shows that the delays are so high that small mismatch probabilities below 50% are not even reachable even with update periods as small as 0.5 seconds (right and top end of graph). For even higher update rates, the $mmPr$ would actually decrease further (due to the assumption of i.i.d exponential delays and the resulting order statistic properties of the smallest sample). However, such scenarios are not realistic as eventually the limited communication network bandwidth would lead to increased delays, see Section C.3.4. The artifacts shown in Fig. C.3b, for example at the right with $mmPr$ of 0.7 is due to statistical fluctuation and stochastic nature of the simulations.

C.3.4 Quantitative Analysis of Smart Meter Update Rates Over Update Rate Dependent Delay Model

To investigate a load dependent delay communication scenario, a linear increase of mean network delays for increasing smart meter update rate is considered next, i.e. $\nu_{sm} = a \cdot \tau_{sm} + b$, where a and b are chosen to maintain a delay range of 0.2s to 2.5s covering the range for a PLC scenario and τ_{sm} range of 0.02 to 2. The choice of linear dependency provides a simplified assumption for analysing the impact of network traffic (increased τ_{sm}) on ν_{sm} . For the model of communication network at the data concentrator layer, $\nu_a = 250\text{ms}$ is considered, which is inspired by a 3G communication scenario [27].

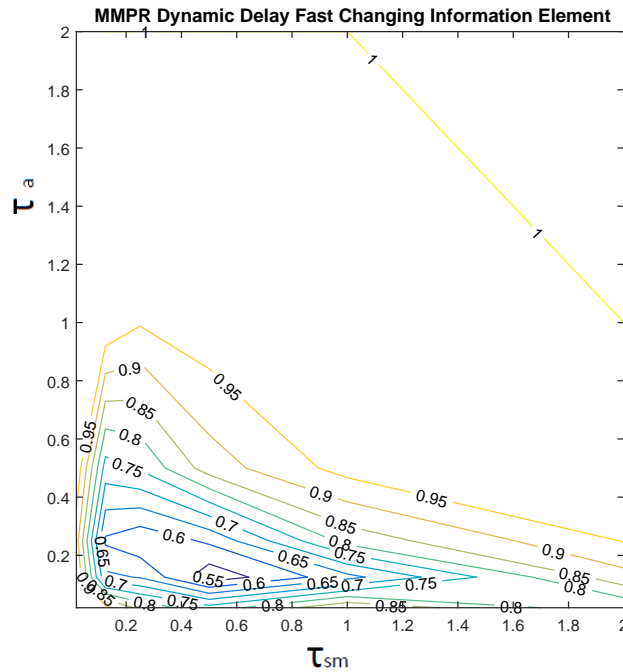

Fig. C.4: Update Rate Combinations to fulfil mmPr requirement bounds for fast changing information element with mean time between information change of 10s and a linearly growing network delay between smart meter and concentrator for increasing τ_{sm} .

As can be seen in Fig. C.4, due to the impact of the linearly dependent network model, update rate combinations of τ_{sm} of 2 and τ_a of 2 lead to an mmPr of 1 unlike Figs. C.3a and C.3b. The circular shape of the mmPr curves in Fig. C.4 shows that there is a minimum for the mmPr; the value of the minimum in these simulation results

is between 0.5 and 0.55 and it is achieved for $\tau_{sm} \approx 0.46$ and $\tau_a \approx 0.17$. To study the impact of change of information element, we have also tested a scenario with λ of $1/60s$. The lower λ does not seem to impact the update rate combinations to have an absolute minimum of the mmPr in Fig. C.4, although the mmPr values are lower due to the slow changing information element.

C.4 Summary and Outlook

This article provides a general overview of adaptive data collection functionalities for monitoring of distribution grid through the existing smart metering infrastructure. The results presented in the paper show that update rate configurations at smart meter and data concentration layers can be used to adapt the data collection system. A performance metric mmPr is introduced and used for quantitative analysis of two layer data access infrastructure.

The simulation analysis performed in this paper is based on stochastic assumptions, the future plan is to collect measurement traces from smart meters via measurement campaign and use the measured values to make further quantitative analysis. In addition, procedures for online adaptation of update rates will be developed and tested in Real-Time hardware in the loop (HIL) integration and in field tests.

Acknowledgment

This work is financially supported by the Danish project RemoteGRID which is a ForsKEL program under Energinet.dk with grant agreement no. 2016-1-12399.

References

- [1] J. Zheng and D. W. Gao and L. Lin, *Smart Meters in Smart Grid: An Overview*, Green Technologies Conference, 4-5, Denver, USA, April 2013.
- [2] *REMOTEGRID - REliable MOniToring and Estimation of distribution GRID for smart societies*, [Online], Available: <http://www.remotegrid.dk/> 2015.
- [3] K. D. Craemer and G. Deconinck, *Analysis of State-of-the-art Smart Metering Communication Standards*, Proceedings of the 5th Young Researchers Symposium, IEEE, 2010.
- [4] M. Kemal, R. Olsen, *Adaptive Data Collection Mechanisms for Smart Monitoring of Distribution Grids*, 12th European Dependable Computing Conference (EDCC 2016), Gothenburg, Sweden, (Proceedings of Student Forum), September 5-9, 2016.

- [5] IEC 62056-58, *Data exchange for meter reading, tariff and load control, Part 58: Smart Message Language*, 2006.
- [6] IEC 62056-62, *Data exchange for meter reading, tariff and load control. Part 62: Interface Classes*, 2006.
- [7] IEC 62056-53, *Data exchange for meter reading, tariff and load control. Part 53: COSEM application layer*, 2006.
- [8] EN 13757, *Communication system for meters and remote reading of meters*, 2008.
- [9] S.Mohagheghi and J. Stoupis and Z. Wang and Z. Li and H. Kazemzadeh, *Demand Response Architecture: Integration into the Distribution Management System*, Smart Grid Communications (SmartGridComm), 2010.
- [10] N.N. Naik and M.N Dhend, *Development of Smart Meter for Distribution System Monitoring*, Discovery The International Journal, 2015.
- [11] J. Anderson, A. Sadhanala and R. Cox, *Power Quality, Smart Meters and Additional Information from Different Power Terms*, IEEE Latin America Transactions, 158-165, 2015.
- [12] W. Angelino de Souza and F. Pinhabel Marafao and E. Verri Liberado and I. Severino Diniz and P. J. Amaral Serni, *Using smart meters for load monitoring and active power-factor correction*, IECON 2012-38th Annual Conference on IEEE Industrial Electronics Society, 2012.
- [13] *Smart Control of Energy Distribution Grids over Heterogeneous Communication Networks*, [Online], Available: "<http://www.smartc2net.eu/>".
- [14] M. Findrik, Th. Kristensen, Th. Hinterhofer, R. L. Olsen, H. Schwefel, *Information-Quality based LV-Grid-Monitoring Framework and its Application to Power-Quality Control*, Ad Hoc Now, June 2015.
- [15] T. Kristensen, R. Olsen, J. Rasmussen, *Analysis of Information Quality in event triggered Smart Grid Control*, Vehicular Technology Conference 2015-Spring, May 2015.
- [16] R. Olsen, H. Peter Schwefel, T. Le F. Kristensen, J. Theilgaard Madsen, L. Cristiana Totu, *Utilizing Network QoS for Dependability of Adaptive Smart Grid Control*, IEEE Energycon 2014, May 2014.
- [17] *Smart Energy System Laboratory*, [Online], Available: "<http://www.et.aau.dk/departament/laboratory-facilities/smart-energy-systems-lab/>".

- [18] M. Simonov and G. Zanetto, *Event-based hybrid metering feeding AMI and SCADA*, Event-based Control, Communication, and Signal Processing (EBCCSP), 2015.
- [19] Yihua Hu a, Wenping Cao b, Bing Ji c, Jikai Si d, Xiangping Chen, *New multi-stage DC-DC converters for grid-connected photovoltaic systems*, Renewable Energy, An International Journal, 2014.
- [20] R. Olsen, H. Peter Schwefel, B. Martin, *Quantitative analysis of access strategies to remote information in network services*, Global Telecommunications Conference, CLOBECOM 2006.
- [21] B. Martin, R. Olsen, H. Peter Schwefel, *Probabilistic models for access strategies to dynamic information elements*, Performance Evaluation, 67(1), 43–60, 2006.
- [22] y. Hu, A. Kuh, A. Kavcic, *Real-time State Estimation on Micro-grids* 0.4emIEEE Computational Intelligence Magazine, 2011.
- [23] J. Garcia, P. Hurtig, and A. Brunstrom, *DiSC: A Versatile and Flexible Emulation System*, Swedish National Computer Networking Workshop (SNCNW08), Sweden, 2015.
- [24] M.Dong, P.C.Meira, W.Xu, W.Freitas, and A. Brunstrom, *An Event Window Based Load Monitoring Technique for Smart Meters*, IEEE TRANSACTIONS ON SMART GRID : Vol.3, No.2 2012.
- [25] R.Pedersen, M.Findrik, C.Sloth, and H.P.Schwefel, *Adaptive Power Balancing over Congested Communication Links*, SUSTAINABLE ENERGY GRIDS AND NETWORKS, Submitted: Aug 2016.
- [26] *ESSnet Big Data, Work Package 3: Smart Meters*, [Online], Available: "https://webgate.ec.europa.eu".
- [27] Findrik, Mislav and Pedersen, Rasmus and Hasenleithner, Eduard and Sloth, Christoffer and Schwefel, Hans-Peter, *Test-bed assessment of communication technologies for a power-balancing controller*, 2016 IEEE International Energy Conference (ENERGYCON), Submitted: 2016.

Paper D

Optimized Scheduling of Smart Meter Data Access: A Parametric Study

Mohammed S. Kemal, Rasmus L. Olsen and Hans-Peter Schwefel

The paper has been published in the
*2018 IEEE International Conference on Communications Workshops (ICC
Workshops)*, 2018.

© 2018 IEEE
The layout has been revised.

Abstract

Active low-voltage distribution grids that support high integration of distributed generation such as photovoltaics and wind turbines require real-time voltage monitoring. At the same time, countries in Europe such as Denmark have close to 100% rollout of smart metering infrastructure. The metering infrastructure has limitations to provide real-time measurements with small-time granularity. This paper presents an algorithm for optimized scheduling of smart meter data access to provide real-time voltage quality monitoring. The algorithm is analyzed using a real distribution grid in Denmark. Results show improved information quality for real-time monitoring in comparison to heuristically chosen scheduling mechanisms.

D.1 Introduction

Smart meters (SMs) have been deployed in many countries and measure energy and voltages at customer connection points, but this information is mainly used today for billing. On the other hand, the Distribution System Operator (DSO) does not know about Low Voltage (LV) grid state unless customers call and complain about outages and flicker. The SM measurements can be useful for distribution grid observability applications such as voltage quality monitoring, but due to the resource-constrained communication networks, it is challenging to obtain the relevant measurements in near real-time [1].

Advanced metering infrastructure (AMI) is composed of SMs, communication networks and an integrated data management system also known as Head-End (HE). AMI primarily facilitates bi-directional communication between customers and Distribution System Operator (DSO) centers [1]. Figure D.1 depicts a high-level architecture of an AMI system consisting of SMs, Data Concentrators (DCs) and HE. A typical AMI communication network involves either PLC or multi-hop wireless mesh network for a periodic update from SMs to DCs, but in some cases, it may also use GPRS and 3G to reach isolated SMs. A different communication link between DC to HE provides aggregated data to the integrated data management system and further to the DSO [3].

The low bandwidth AMI communication networks result in infrequent updates of data and high latency which strongly affects data quality in real-time applications. Classically, the information age, i.e., time from measurement until the data is being utilized, is used to indicate its current validity. However, linking the information age to information dynamics leads to another metric, the so-called mismatch probability (mmPr), which in previous work, see [4], has shown to be a useful metric for describing information quality. The optimization problem that we investigate in this paper focuses on delivering useful information, i.e., provide a high information quality; hence we focus on mmPr. As presented in our previous work in [5] [6], the ordering of SMs in round-

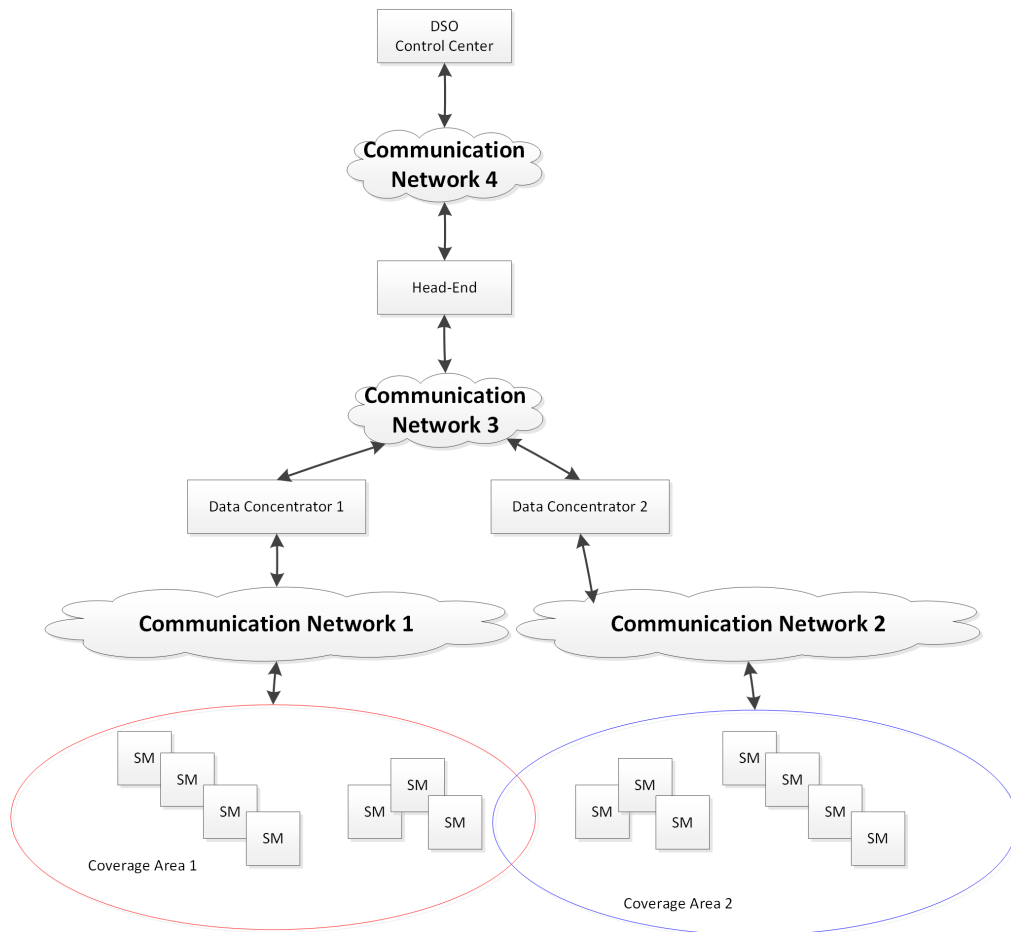

Fig. D.1: AMI system architecture [4]

robin access, called schedule, influences information age which we in this paper refer to as Age.

Further, we showed that this schedule affects the mismatch probability. The mismatch probability is used in an earlier proposed optimized data access algorithm (ODAS) to search for an optimal schedule heuristically. Initial analysis in the context of voltage monitoring application data access algorithm (ODAS) to heuristically search for an optimal schedule. Initial analysis in the context of voltage monitoring application [6] showed an improved information quality; this paper provides a systematic and rigorous analysis of ODAS for small-scale scenarios, in which a comparison with other schedules can be achieved by brute-force enumeration.

The contribution of this paper is summarized as 1) Analysis of the impact of the schedule on information age 2) study the behavior of SM information by using LV-grid voltage measurements 3) investigate the impact of SM scheduling on mmPr and 4) performance analysis of the earlier developed heuristic algorithm (ODAS). The paper is structured as follows: Section D.2 presents related work followed by the system description in Section D.3. Section D.4 describes and reports results from a systematic parametric study of the impact on mmPr when varying different system parameters for all possible schedules. ODAS is evaluated in Section D.5 and followed by the conclusion.

D.2 Related Work

The mmPr achieved by access schedules is affected by the following two main factors 1) properties of the communication networks and 2) time-variability of information. There has been a significant amount of interest regarding adapting scheduling purely based on communication network properties. For example, joint routing and TDM-based scheduling in wireless mesh networks are studied in [7], [8], and [9]. Those papers optimized the scheduling algorithm by capturing communication network constraints incurred due to wireless interference. Accurate traffic information is taken into consideration, for example, in [7], active source and destination sets with known traffic demand for the source-destination pair are required for the optimization. But in realistic scenarios with stochastic traffic patterns, it is hard to obtain and estimate network performance. Paper [8] assumes joint routing, scheduling, and power control by considering that every link in the network is active. In [9] joint routing, channel allocation, and scheduling are studied, but as in [7] traffic demand is required to be known for active source and destination pairs.

Future 5G technologies aim to support services such as enhanced mobile broadband (emBB) and ultra-reliable low-latency communications (URLLC) with the aim to simultaneously realize requirements for mixture of users and applications. There is an extensive study on how to efficiently distribute the resource between emBB traffic and URLLC traffic on a shared medium. For example, schedulers are proposed by allowing

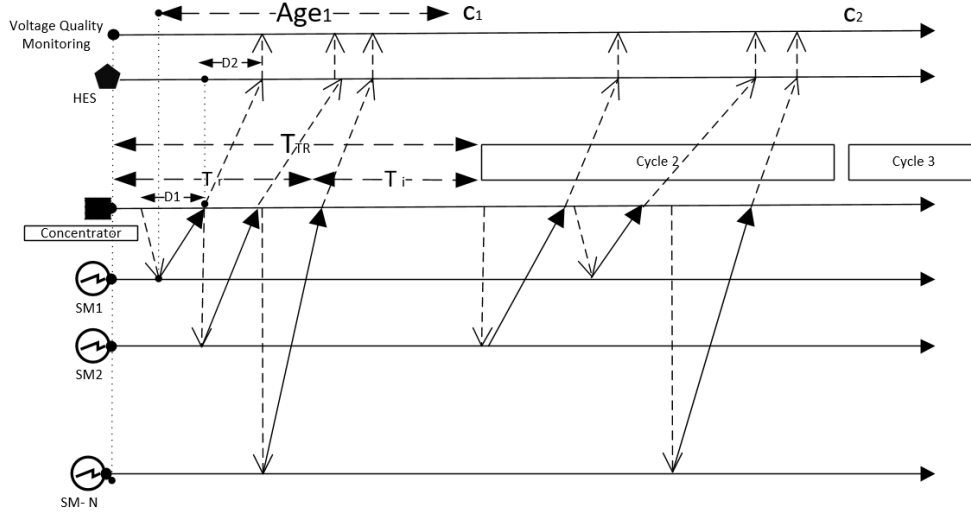

Fig. D.2: Two level SM data access infrastructure one can notice in the diagram that the sequential pull access policy for cycle 1 is (SM1,SM2,SM3) and (SM2,SM1,SM3) in cycle 2, dynamic schedule [6].

users to transmit with variable transmission time intervals as introduced in [10], [11] and [12].

To date as outlined above most of the work focuses to adapt schedules on link layers by using a metric that treats nodes equally or taking stochastic assumptions regarding the information dynamics. In this work, by utilizing mismatch probability, we aim to capture the combined effect of both communication network properties and information dynamics to optimize SM data access scheduling.

D.3 System Description

Voltage quality monitoring (VQM) is the motivating use case for the parametric study, see Fig. D.2. VQM functionality at DSO control center expects to utilize voltage measurements from SMs for LV distribution grid voltage control. For instance [8] uses VQM for voltage control by adjusting reactive power to ensure that the LV grid satisfies the grid code by keeping average operation voltages within 10% of the nominal voltage values [14].

In this work, motivated by scenarios of low bandwidth radio mesh networks for SM

communication, the DC sequentially pulls N SMs in a round-robin fashion. In addition to the standard energy measurements, the SM is assumed to also measure averages over RMS voltage at the connection point over some time period. Today's deployed SMs typically measure average values over intervals from 15 minutes to an hour and with the trend towards shorter time periods down to few minutes and even a single second, [15], [16].

Today, The DC pulls SM measurements sequentially within a cycle that repeats with a total reading time of T_{TR} (see Fig. D.2). T_r is the time for the DC to pull all SMs in range. The remaining time is Idle time.

$$T_I := T_{TR} - T_r \quad (\text{D.1})$$

The idle time is reserved for functionalities such as firmware updates and critical alarm occurrences. D_1 represents the round trip communication delay between the DC and SM. D_{con} is the concentrator processing time which is not specified in Fig. D.2 due to space constraints, while D_2 represents a one-way delay of between DC and HE. The moment of monitoring execution C_i is done at every T_{TR} cycle to ensure VQM gets all SM data from the most current reading cycle. The order at which SMs are polled from the DC we refer to as schedule and it is via this schedule we seek to provide the best possible information quality measured in terms of mismatch probability.

D.3.1 Information Quality Metrics

Two metrics are in scope of this paper, both related to information quality linked with timely behavior. First is the classical information age, which is used very often [4]; the second metric, mmPr, is a more complex one that puts the information age in perspective to the information dynamics. The order of the N SMs in the schedule affects the information age, defined as the time interval from the end of the measurement interval at the SM until the information is utilized by VQM (C_i in Fig. D.2).

$$Age^{(j)} = t_{VQM,i} - t_i^{(j)} \quad (\text{D.2})$$

In this work, we are looking at the impact of scheduling on information age first and afterwards analyze the effect on mismatch probability.

Mismatch probability (mmPr): in this context defined as the probability that information at the voltage quality monitoring level, during the time, C_i , of monitoring execution does not match within the voltage sensitivity thresholds ϵ with the true voltage measurand value at the SM at that time instant (see Equation 3) [5].

$$mmPr := Pr(V_{SM_j}(C_i) - V_{SM_j}(C_i - Age_j) < \epsilon) \quad (\text{D.3})$$

D.4 Parametric Study

The primary goal of this parametric assessment is to have a systematic understanding of the impact of SM scheduling on information quality. To execute this study, we answer the following research questions in this chapter: 1) What is the influence of SM scheduling on information age? 2) How do SM voltage measurements from LV-grid scenarios behave over time in a given representative scenario?, and 3) What is the impact of SM scheduling on information quality as described by mmPr?

D.4.1 Smart Meter Scheduling Parameters

To assess the impact of the access scheduling, we performed an analysis based on the system in Fig. D.2. For N Smart Meters and deterministic D_1 and D_{con} and sufficient idle time $t_I > D_2$, we get the following relations:

$$T_r = N \cdot (D_1 + D_{con}) \quad (\text{D.4})$$

$$Age_{min} = T_I + \frac{D_1}{2} + D_{con} \quad (\text{D.5})$$

$$Age_j = Age_{min} + (D_1 + D_{con}) \cdot (N - j) \quad (\text{D.6})$$

$$Age_{max} = Age_{min} + (N - 1) \cdot (D_1 + D_{con}) \quad (\text{D.7})$$

We configured the parameters in Tables D.1 and D.2 so that the DC reads through the N SMs in one cycle.

N	T_{TR}	T_I	Age_{min}	Age_{max}
5	75	20	26	70
6	90	24	30	85
7	105	28	34	100
10	150	40	46	145

Table D.1: 1-Hop Scenario

N	T_{TR}	T_I	Age_{min}	Age_{max}
5	375	120	146	350
6	450	144	170	425
7	525	168	194	500
10	750	240	266	725

Table D.2: 5-Hop Scenario

We use up to 10 SMs as it is viable to assess all permutations of policies only with a low number of SMs. For a secondary substation typically there are between five and some hundred SMs connected. We focus on 10 SMs because 1) the computational effort in assessing more becomes high as the effort for the validation of our algorithm grows as $O(N!)$, 2) the scenario with ten selected SMs is realistic as not all parts of the electrical grid are equally important to monitor. We use total reading time T_{TR} based on the

round trip SM to DC delay, for N SMs, and providing idle time T_I (AMI functional requirement). The choices of D_1 and D_2 are motivated by meshed networks and 3G scenarios respectively. While these delays depend on the packet sizes, and thus on the number of measurements to be transmitted, we assume here a fixed size leading to a constant delay. As in realistic AMI systems with meshed networks [4], 1-hop and 5-hop scenarios are chosen to study best and worst case scenarios for the parametric studies. The fixed parameters used for the parametric studies are $D_1 = 1/4s$, motivated by a 3G communication scenario; when using 1-hop delays of $D_1 = 10s$, Tables D.1 and D.2 show Age_{min} and Age_{max} values for the 1-hop scenario and 5-hop scenario, respectively.

D.4.2 Low-Voltage Grid Scenarios

Two low-voltage grid scenarios are studied in this work.

Sc2Net Grid, Denmark The first one is the reference grid modelled as part of the project [17]. The household model is based on real consumption traces in Denmark. This grid has three combined PV energy storage systems and five PV installations combined with households. LV grid monitoring uses the measurement from each household via SMs. The description of asset models and consumption data is outlined in [13], and the detailed elaboration of the grid model can be found in [8]. The resolution for this reference grid data sets is 5s.

The voltage behavior at each node depends on household consumption and presence of PV and energy storage. For example, we can see in Fig. D.3 the variability of voltage measurements due to the PV connected to SM1 (while the household behind SM2 does not contain any PV).

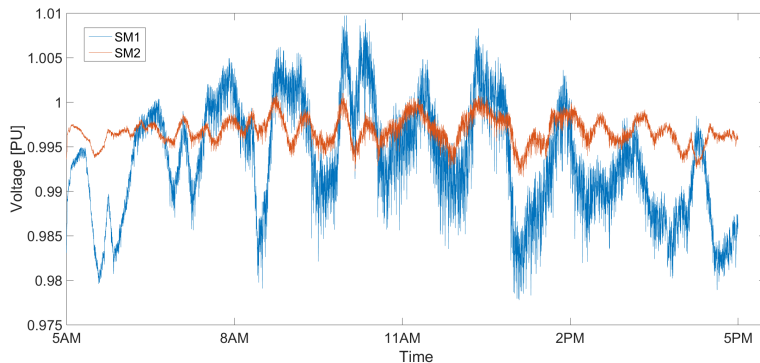
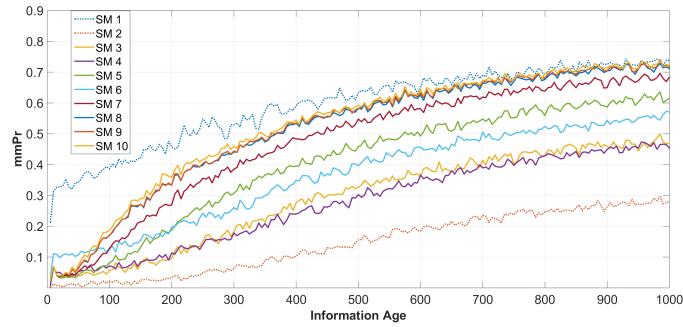

Fig. D.3: Reference grid SM traces, voltage variations for selected SMs

ADRES data, Austria [19] contains high-resolution (1second) measurements of power and voltage from 30 Austrian households.

Figures D.4a and D.4b demonstrate the information dynamics for selected 10 SMs for both grids.



(a) Calculated mmPr-information age relationship for the Sc2Net Grid: notice the impact of voltage measurement dynamics on SM1 and SM2 as seen in Fig. D.3.

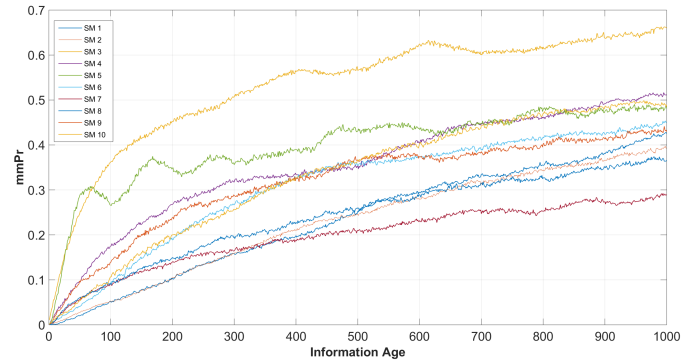

(b) Calculated mmPr-information age relationship, ADRES data

Fig. D.4

We used a sliding window mechanism to obtain the mmPr over increasing information ages from the measurement data for an mmPr threshold of $\epsilon = 1V$ (See Equation 3). The latter choice was obtained from an analysis with varying ϵ - not shown here due to space constraints. We can see three main findings in this study: 1) the mmPr of SM measurements for varying ages behaves differently for different SMs as the voltage variability is different in different grid points. 2) Information age affects information quality (mmPr) in a nonlinear way, and 3) the impact of the information age on information quality is bounded. As opposed to using only age as a metric, which is independent of

the behavior of the measurand and hence of the specific measurement point, and furthermore grows unboundedly, the mmPr provides a means to differentiate information from the various SMs and further provides an indication of the relevant age range that has impact for an optimization. These observations motivate the optimization algorithm described in later sections.

To answer the third question and understand the impact of SM scheduling on information quality, we analyzed all possible permutations of schedules and obtained via brute-force search the minimum and maximum of the resulting average mmPr. Figures D.5a and D.5b show the difference between worst and best schedules for up to $N = 10$ accessed SMs.

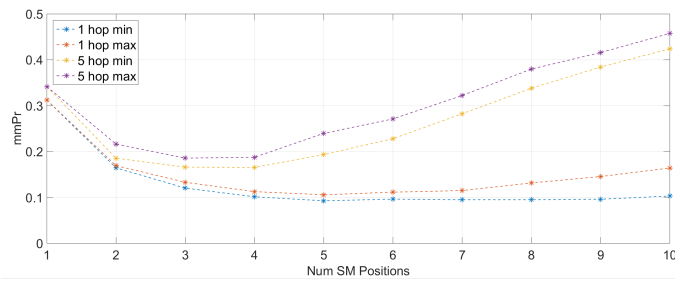

(a) Parametric comparison of actual minimum and actual maximum average mmPrs Sc2Net Grid

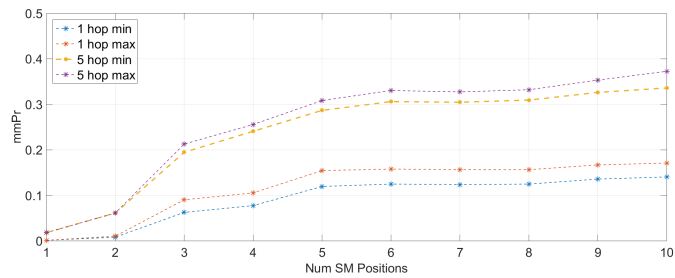

(b) Parametric comparison of actual minimum and actual maximum average mmPrs Reference ADRES Grid

Fig. D.5

For the Sc2Net 1-hop case in Fig. D.5a, as N increases the margin between max and min values increases. In contrast to that, the margin seems to stay approximately constant for $N = 5$ and onwards in the 5-hop scenario. For the ADRES data in Fig. D.5b, the margin gets bigger with N for both the 1-hop and 5-hop cases. We observe the differences in the two grids, meaning that the optimal schedule in one is not necessarily an optimal schedule in the other grid. The difference between the best and worst schedule

also indicates that there is quite a range of schedules having different mmPr impact. The aim of our algorithm in the next part is to determine solutions that are close to the lowest mmPr boundary.

To study further the impact of D_1 for SM measurements, we chose one scenario with $N = 10$ and 1-hop. The 10SM case is selected because it shows higher relative average mmPr differences when compared to the remaining cases. Figure D.6 shows the impact of D_1 on the minimum and maximum of the average mmPr across all schedules. Both grids show a general decline on mmPr margin due to increase in D_1 as expected. We also varied other system parameters, most notably ϵ and the averaging interval of the measurements. These results are not shown here due to space constraints.

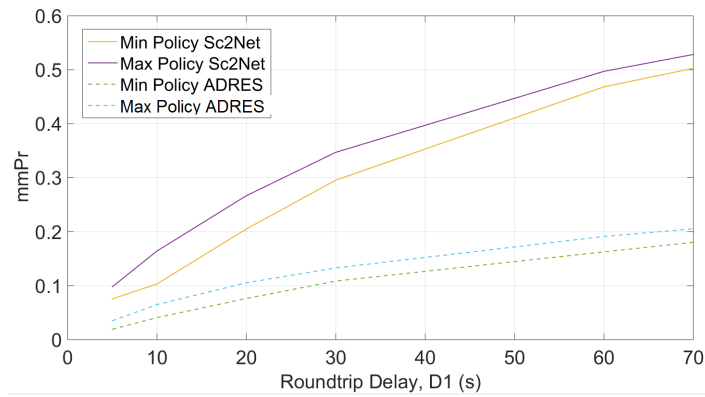
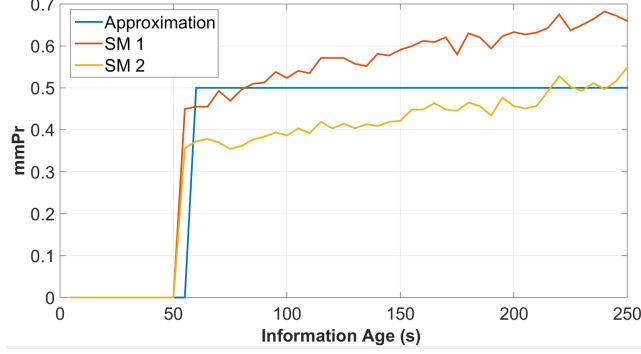

Fig. D.6: Parametric comparison impact of delay on min and max mmPrs for Sc2Net Grid and ADRES Grid

D.5 Optimized Data Access Scheduling Algorithm

In prior work [6], ODAS, the heuristic optimization using the step function approximation showed improvement when compared to heuristically chosen poor schedules. ODAS uses a step function relationship between age and mmPr [6]. The mmPr over age approximation of the selected 10 Sc2Net SMs is approximated by two-step functions as shown in Figs. D.7a and D.7b.

ODAS assigns the 10 SM to two SM information classes based on their mmPr over age behavior. Based on the minimization of the mean squared error (MSE), two of the SMs are clustered as Class 1 (blue) and eight for Class 2 (yellow) SMs. As ODAS scheduling minimizes the mean mmPr, and the choice between different access positions is only affected by the difference of the mmPr values, we shift all functions of Fig. D.4a downwards first so that they show mmPr=0 at the smallest relevant information age of 46s.



(a) Step function approximation class 1

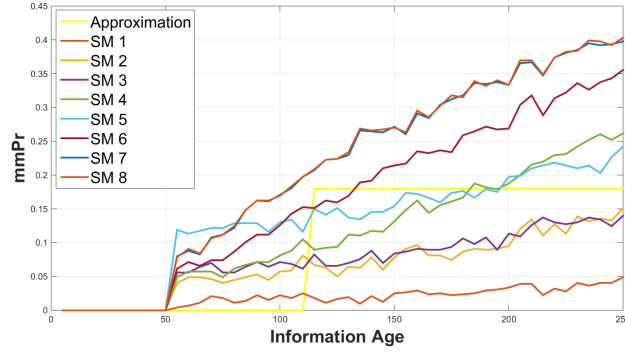

(b) Step function approximation class 2

Fig. D.7

To assess ODAS, we use the actual min and max average mmPr of the selected cases in Section D.3. The actual maximum and minimum average mmPr for $N = 10$ in the 1-hop scenario are 0.16429 and 0.10322 respectively (see Fig. D.5a and D.8). We introduce the following two degradation parameters:

Deg_{min} , relative degradation to the actual minimum mmPr:

$$Deg_{min} = \frac{(mmPr - mmPr_{min})}{(mmPr_{min})} \quad (D.8)$$

Deg_{range} , relative degradation to the achievable mmPr range:

$$Deg_{range} = \frac{(mmPr - mmPr_{min})}{(mmPr_{max} - mmPr_{min})} \quad (D.9)$$

To analyze the advantage of using ODAS, we select 7 cases from the previous parametric study with reasonable ranges between actual min and actual max policies as seen in Table D.3.

Table D.3: Test Cases

Case	Num SM	Num Hop	D_1	Vol. Sensitivity
Case 1	10	1	10s	1V
Case 2	9	1	10s	1V
Case 3	10	1	5s	1V
Case 4	10	1	20s	1V
Case 5	10	1	40s	1V
Case 6	10	1	10s	0.5V
Case 7	8	5	50s	1V
Case 8	6	5	50s	1V

Figure D.8 shows the mmPr comparison for the 7 cases, in which the ODAS schedule is compared to the average of 10000 selected random policies. Further, Table D.4 shows additional comparison by using the degradation metrics. Although ODAS outperforms the average mmPr of the selected random policies, the last column in Table D.4 shows that the suboptimal solution based on the step function approximation does not seem to perform as well in Scenarios 4, 6, and 7; these cases will be investigated for further improvements of ODAS in the future.



Fig. D.8: Comparison of ODAS to actual min, actual max and randomly selected schedules

Table D.4: Relative Degradation Comparison

Cases	ODAS		P (ODAS<Random)
	Deg Min	Deg Range	
Case 1	14.65%	24.52%	87%
Case 2	7.73%	15.03%	92%
Case 3	9.64%	32.50%	82%
Case 4	13.32%	44.31%	70%
Case 5	2.69%	29.21%	82%
Case 6	12.27%	71.83%	64%
Case 7	6.27%	50.63%	62 %
Case 8	3.48%	18.37%	96%

D.6 Conclusion

Smart meters located in distribution grids can be used for voltage quality monitoring, however there are challenges to provide real-time data access. Adapting the order of access of the Head-End to the SMs influences the quality of the obtained measurement data. To have a systematic understanding of the impact of such scheduling on the quality of real-time information, this paper first introduces the data access infrastructure and information quality metrics, here information age and mismatch probability. Smart meter measurements of voltages from two different grid scenarios are used, in which different SMs show different variability of voltage values and hence the relation between information age and mmPr behaves differently. We analyze a previously proposed heuristic algorithm, called ODAS, in comparison to achievable maximum and minimum mmPrs by brute force enumeration of all possible schedules. This analysis is performed when varying different system parameters and shows that ODAS is in many cases close to the achievable best schedule. Although the absolute improvements of the mismatch probabilities using ODAS does not appear to be very high, the relative improvements are quite big for some cases, in particular compared to random schedules. When the number of nodes increases, for which it becomes increasingly difficult to find the optimal solution via brute-force enumeration, ODAS offers a relatively simple and computational more efficient approach to locate a for a good schedule, while the paper also identified room for further enhancements.

Acknowledgment

This work is financially supported by the Danish project RemoteGRID which is a ForsKEL program under Energinet.dk with grant agreement no. 2016-1-12399

The ADRES consumption measurements were generated generated in the research project “ADRES-CONCEPT” (EZ-IF: Development of concepts for ADRES – Autonomous Decentralized Regenerative Energy Systems, project no. 815 674). This project was funded by the Austrian Climate and Energy Fund”

References

- [1] Advanced metering infrastructure and customer systems. [Online]. Available: <http://SMARTGRID.gov/>
- [2] Remotegrid. [Online]. Available: <http://www.remotegrid.dk/>
- [3] R. Sanchez, F. Iov, M. Kemal, M. Stefan, and R. Olsen, “Observability of low voltage grids: Actual dsos challenges and research questions,” in *2017 52nd International Universities Power Engineering Conference (UPEC)*, Aug 2017, pp. 1–6.
- [4] M. Bogsted, R. L. Olsen, and H.-P. Schwefel, “Probabilistic models for access strategies to dynamic information elements,” in *Performance Evaluation*, vol. 67, no. 1, Jan 2010, pp. 43 – 60.
- [5] M. Kemal, R. Olsen, and H. Schwefel, “Information quality aware data collection for adaptive monitoring of distribution grids,” in *EAI International Conference on Smart Grid Assisted Internet of Thing*, Jul 2017, pp. 1–6.
- [6] M. S. Kemal, R. L. Olsen, and H.-P. Schwefel, “Optimized scheduling of smart meter data access for real-time voltage quality monitoring,” in *Ieee International Conference on Communications*, 2018.
- [7] K. Jain, J. Padhye, V. N. Padmanabhan, and L. Qiu, “Impact of interference on multi-hop wireless network performance,” in *Proceedings of the 9th Annual International Conference on Mobile Computing and Networking*, ser. MobiCom ’03. New York, NY, USA: ACM, 2003, pp. 66–80.
- [8] R. L. Cruz and A. V. Santhanam, “Optimal routing, link scheduling and power control in multihop wireless networks,” in *IEEE INFOCOM 2003. Twenty-second Annual Joint Conference of the IEEE Computer and Communications Societies (IEEE Cat. No.03CH37428)*, vol. 1, March 2003, pp. 702–711 vol.1.
- [9] J. Zhang and Z. J, “Joint routing and scheduling in multi-radio multi-channel multi-hop wireless net-works.”
- [10] Q. Liao, P. Baracca, D. Lopez-Perez, and L. G. Giordano, “Resource scheduling for mixed traffic types with scalable tti in dynamic tdd systems,” in *2016 IEEE Globecom Workshops (GC Wkshps)*, Dec 2016, pp. 1–7.

- [11] K. I. Pedersen, M. Niparko, J. Steiner, J. Oszmianski, L. Mudolo, and S. R. Khosravirad, "System level analysis of dynamic user-centric scheduling for a flexible 5g design," in *2016 IEEE Global Communications Conference (GLOBECOM)*, Dec 2016, pp. 1–6.
- [12] G. Pocovi, B. Soret, K. I. Pedersen, and P. Mogensen, "Mac layer enhancements for ultra-reliable low-latency communications in cellular networks," in *2017 IEEE International Conference on Communications Workshops (ICC Workshops)*, May 2017, pp. 1005–1010.
- [13] T. le Fevre Kristensen, R. L. Olsen, J. G. Rasmussen, and H.-P. Schwefel, "Information access for event-driven smart grid controllers," *Sustainable Energy, Grids and Networks*, pp. –, 2017.
- [14] A. K. Kumar, Pradeepand Singh, *Grid Codes: Goals and Challenges*. Singapore: Springer Singapore, 2014, pp. 17–39.
- [15] M. Plaisance. Holyoke gas and electric customers could net savings from ongoing meter study involving high performance computing center. [Online]. Available: <http://www.masslive.com/news>
- [16] egauge energy monitoring solutions, 2018. [Online]. Available: <http://www.egauge.net/>
- [17] Smart control of energy distribution grids over heterogeneous communication networks. [Online]. Available: <http://www.smartc2net.eu/>
- [18] R. Pedersen, C. Sloth, G. B. Andresen, and R. Wisniewski, "Disc: A simulation framework for distribution system voltage control," in *2015 European Control Conference (ECC)*, July 2015, pp. 1056–1063.
- [19] e. a. Einfalt, A. onzeptentwicklung fur adres - autonome dezentrale erneuerbare energie systeme, endbericht, wien 2011. [Online]. Available: <https://www.ea.tuwien.ac.at>

Paper E

On the Trade-off Between Timeliness and Accuracy for Low
Voltage Distribution System Grid Monitoring Utilizing Smart
Meter Data

Mohammed Kemal, Ruben Sanchez, Rasmus Olsen, Florin Iov, and
Hans-Peter Schwefel

The paper has been submitted to the
IEEE Transactions on Industrial Informatics journal, 2019.

© 2019 IEEE
The layout has been revised.

Abstract

At the low voltage level of the power grid, distribution system operators face new challenges due to the increasing penetration of the so-called distributed energy resources such as photovoltaic panels, small scale wind turbines, electric vehicle charging stations and heat pumps. The first step towards a smarter operation comprises to increase the low voltage grids monitoring capabilities. At the same time, some countries in Europe such as Denmark have close to 100% roll-out of smart metering infrastructure. Smart meters have promising potential in supporting low voltage grid monitoring solutions. However, due to the low bandwidth communication technologies, it is not possible to develop monitoring systems which require large amounts of smart metering data. This paper identifies low voltage monitoring system requirements and limitations due to actual involved systems, i.e., 1) low voltage grids with new types of loads and generation units and 2) existing smart metering communication technologies. Then, a novel concept of embedding periodical data collection for monitoring purposes utilizing idle periods of legacy smart meter systems is presented. Weighted least squares state estimation is used to reconstruct snapshots of the low voltage grid state by using a limited amount of smart metering data. Quantitative analysis shows the collective impact of the number of accessed smart meters on the accuracy and delay of the monitoring application.

E.1 Introduction

In recent years, the electrical behavior of Low Voltage (LV) grids has been transforming due to the increasing penetration of Distributed Energy Resources (DER) [1]. Traditionally, the generation of power required to feed the loads of the entire electrical grid was centralized in large power plants placed at the High Voltage (HV) level where the LV grids were merely seen as loads. However, this operational philosophy is changing due to the appearance of Decentralized or Distributed Generation (DG) based on Renewable Energy Sources (RES) such as Photo Voltaic (PV) panels or small scale wind turbines. Additionally, a new type of loads such as single-phase connected heat pumps, electric boilers or Electrical Vehicles (EV) produce voltage and power profiles never seen before at the LV level. In this paper, an active LV grid refers to the new electrical reality of the current LV grids. However, these new loads and DGs can cause technical challenges, such as sudden voltage dips and swells, unexpected and uncontrollable voltage variations, congestion or bidirectional power flows [2]. In this frame, Distribution System Operators (DSO) lack the technologies required to ensure that the grid fulfills operational requirements defined by grid codes and technical standards. For instance, the awareness in case of faulty conditions relies entirely on customer complaints since abnormal conditions and outages are not automatically reported in the control centers. Moreover, the causes of the problems are often not identified, and system restoration

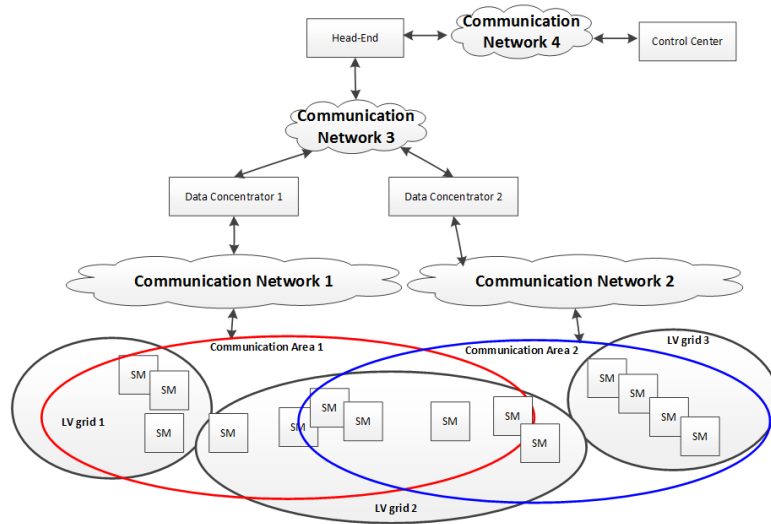

Fig. E.1: AMI system architecture [4]

might last for hours while requiring a significant amount of human resources [3]. Consequently, DSOs desire functions such as effective and optimized outage diagnosis, voltage quality analysis reports, asset management tools, etc. It is intuitive that enabling such services requires as a first step a reliable source of information providing knowledge about the operational grid state. In a power system, the operating conditions can be determined if the grid topology, parameters of lines/cables and complex voltage phasors in every node of the system are known [5]. Since the DSOs operate the power grids from the control centers, this process requires the acquisition of electrical measurements from measurement devices placed throughout the grid. In this regard, in Europe, there is an undergoing deployment of Smart Meters (SMs) at the LV level which is close to 100 % in some countries. However, the raw measurements from the devices cannot be directly considered since they contain noise due to different sources, e.g. measurement class, gross errors, etc., [5] and have to be processed. Additionally, it might not be economically feasible to acquire measurements from every device. The function in charge of overcoming the concerns above is called state estimator.

State Estimation (SE) was first applied to HV power systems by Fred Schweppe in the 70s [6]. It increased the operational capabilities of system operators enabling to establish energy management systems equipped with an on-line SE [5] among other

functions. Nonetheless, until the deployment of SMs started to take place, there were not telemetered measurements available in the LV grids, and thus, SE techniques could not be implemented. Though in some cases the technologies paving the way towards the on-line implementation of monitoring systems are almost entirely deployed, those functions are not yet in place in LV grids.

Weighted Least Square (WLS) based SE is the most widely used and investigated technique specially applied to the monitoring of high and medium voltage grids. As detailed in [7] its application to LV grids is not a straightforward procedure and aspects of different nature need consideration. The main challenges could be grouped into increased computational requirements, accentuated numerical instability issues and the low bandwidth of actual metering systems. Of special interest for this paper are the constraints related to the communication infrastructures deployed for the data acquisition in LV grids, the so-called Advanced Metering Infrastructures (AMI) (see Fig. E.1).

Modern AMI infrastructure encompasses SMs, data concentrators (DC) and central system units defining a new AMI architecture. Figure E.1 illustrates a simplified high-level structure of AMI used in LV distribution grids. From the bottom of the figure, SMs can be connected by different communication technologies such as cellular, PLC, or wireless mesh. In the communication architecture of this paper, the latter case is assumed, while the analysis is relevant to any low-bandwidth communication technology. But in some cases, due to, e.g., low density of SMs in the countryside, some may be relying on other wireless technologies such as GPRS, 3G or other. A DC is responsible for collecting data over some Communication Network (CN) of a given technology based on a given communication link topology. From the DC the collected information is pushed to the head end system (HES) from where information is made available to other components located at DSO control centers via a dedicated interface. In cases where the same communication technology is used to access SMs, the SMs may be overlapping regarding coverages. For example, SMs in coverage area 1 and LV grid 2 can be accessed via concentrator 2 or vice versa. One can see that there is no alignment between AMI topology and grid topology which adds to the complexity for SE solutions utilizing SM information.

The low bandwidth AMI Communication networks result in a very slow update of data and increased delays which affect the quality of information to support near real-time low voltage grid monitoring. Figure E.2 shows a typical AMI reading cycle where a concentrator repeats the pulling of data from all meters periodically with a period of total reading time (T_{TR}). The DC pulls its current view on the SM measurements from all the SMs in the range which results in with reading time T_r . The allocated T_r cannot be changed and must be executed every cycle by AMI operator to fulfill mandatory data for billing of customer consumption. The idle time T_i is the remaining time from the fixed total allocated reading time of T_{TR} ($T_{TR} = T_r + T_i$) [8]. The idle time has a lower bound value (minimum idle time T_{imin}) as there are some system services such as software updates that need to be performed during the idle time and going below this

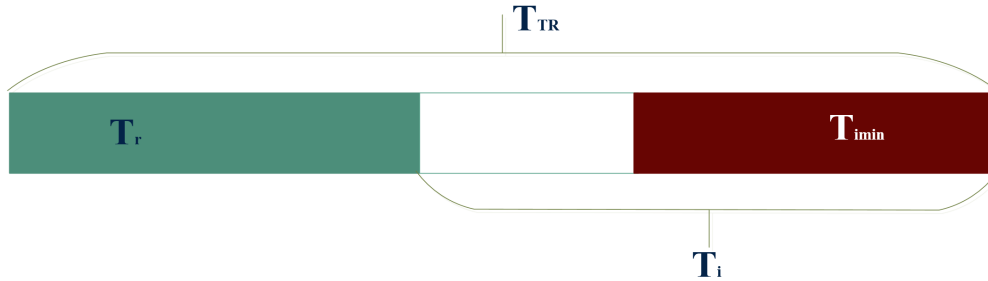

Fig. E.2: AMI reading cycle

would affect services executed at an idle time. The remaining idle time ($T_i - T_{imin}$) can potentially be used for reading selected relevant SMs. The approach in this paper is to utilize the spare idle time to provide additional measurements to be used by SE.

Ideally, implementing monitoring systems for LV grids in near real-time would require to acquire information from every SM placed along the grid to reconstruct an accurate view of the operating scenario. However, the number of SMs (and thus, the number of electrical nodes) in LV grids might rise up to thousands limited by communication technologies of slow update rates [7]. In order to decrease the AMI performance requirements needed to overcome the issue above, smart metering data can be in some cases substituted by the so-called pseudo-measurements which are artificially created measurements based on historical smart metering readings [9]. In case of SM failure or communication network bandwidth constraints, pseudo-measurements are of utmost importance in LV grids to ensure grid observability, which is defined by the SE capability to provide accurate estimates of the entire system given the input measurements. Grid observability depends on the number and position within the grid of available measurements [5].

In comparison with other voltage levels in the power system, LV grids are highly unobservable due to the low ratio between available measurements and system states. Nonetheless, pseudo-measurements are less accurate than SM measurements impacting the performance of the Distribution Systems SE (DSSE) [10]. Thus there exist a trade-off between the capacity of the AMI system to provide relevant measurements and the DSSE performance measured by the accuracy of the estimates states. The capacity of AMI data access system to provide relevant measurements for monitoring is constrained by the spare idle time presented above. The more SM measurements are supplied during the spare idle time; the less the SE utilizes pseudo-measurements and the higher the accuracy. However, there is a maximum time-bound of spare idle time ($T_i - T_{imin}$) that can be used for this purpose. The relationship and trade-off between the capacity of

AMI to provide relevant SM information and accuracy of DSSE is further analyzed in detail in the paper.

The main contributions of the paper can be summarized as follows (i) monitoring of LV grids is approached combining ICT and electrical aspects (ii) propose concepts for embedding periodic data collection for state estimation in idle periods of legacy smart metering systems (iii) propose a methodology to quantify cumulative impact of the number of selected SMs on monitoring system accuracy and delay (iv) provide an outlook on how the presented approaches facilitate future research directions to support near real-time monitoring of LV distribution grids.

The remainder of this paper is laid out as follows: In Section E.2, vital aspects to support near real-time monitoring on existing LV grids are presented and the concept of embedding periodic data collection for state estimation in idle periods of legacy smart metering systems is introduced. The quantitative analysis in Section E.3 presents the trade-off between LV DSSE accuracy and monitoring system delay. Finally, this work is concluded in Section E.4 and an outlook on how to support near real-time monitoring of LV grids is provided.

E.2 Towards Near Real Time Monitoring of LV Grid Using Smart Meter Data

The information in Section E.1 highlights the importance of considering involved systems when dealing with smart grid functions. Referring to LV grid monitoring as the function in scope in this case, this paper investigates how actual systems and technologies could be used to provide a cost-effective solution. For that, key aspects are identified at different levels, i.e. monitoring system requirements based on LV grids behaviour and AMI performance given their actual architecture and operating principle. The latest leads to a discussion of achievable solutions in terms of supporting near real-time monitoring of distribution grids. To enable near real-time monitoring of LV distribution grid by utilizing the existing AMI systems, the data access system should consider 1) electrical behaviour of existing LV grids 2) Constraints on the AMI data access infrastructure.

E.2.1 Requirements for Monitoring Systems in Active LV Grids

For an environment with high penetration of RES at the households level, the grid is susceptible to short and unpredictable power and voltage variations. To give an example, during partially cloudy conditions, PV generation can fluctuate as fast as within a few seconds, influencing part of the LV grid behavior with similar fast dynamics. For instance, the voltage magnitude in nodes placed at the end of long feeders containing multiple PV systems could rapidly rise over the operational limits. A similar impact

is caused by wind speed variations if referring to another type of renewable source of generation, or the unpredictable human behavior to charging of EV when referring to a new kind of load profile. These examples, describe from a general perspective the principles driving the dynamics of active LV grids, which can be summarized as unpredictable, fast-changing and susceptible to violation of operational constraints.

In power systems, the estimated states will be updated in a periodic fashion, event-triggered strategy or a mixture of both [11] [12]. Of course, the followed strategy depends on the technological constraints of measurement devices and communication infrastructures. For instance, in HV grids non-synchronized measurements force to monitor steady states of the systems using measurements gathered every few seconds [13] by the Supervisory Control and Data Acquisition (SCADA) system. On the other hand, using Phasor Measurement Units allows tracking the dynamic behavior of the system due to measurement synchronization and faster reading updates [12].

However, as highlighted in the previous section the update rates of data in AMI systems are far from those mentioned above in case of HV SCADA systems [7]. Therefore, the actual performance and working principles of AMI systems need to be addressed aiming to propose reasonable monitoring strategies which could fulfill the monitoring requirements imposed by the behavior of active LV grids.

E.2.2 AMI Data Access Constraints

The architecture in Fig. E.1 is a logical view of the AMI network, but it also applies to the representation of a physical view defined by the type of communication technology used and geographical representation. There exist many realizations of the communication networks in Fig E.1. For CN1 and CN2 between SMs and concentrators, widely used technologies in Europe are PLC and Radio Mesh technologies. Example of widely used technologies for CN3, CN4 include 3G/4G and Fiber line communication.

The primary constraint for data collection is at CN1 and CN2 due to the low bandwidth technologies deployed between SM and concentrators. Communication technologies and related Quality of Service (QoS) characteristics are thus of paramount importance for LV distribution grid monitoring using AMI systems with a real-time, reliable and efficient bi-directional data flow. Since there are a considerable amount of customers/prosumers located in LV grid, and thus, a large number of potential measurement points, deploying and maintaining traditional wired communication, e.g., Ethernet or Fiber would not be economically feasible for grid operators. Therefore, deployment of widely available existing communication technologies such as wireless cellular, e.g., 2g, 3g and radio mesh networks or PLC present a cost-effective solution for the AMI system. However, this comes at the cost of small data rate, and imperfect/changing QoS properties within the network [14]. For instance, narrowband PLC has data-rate ranging from 10-500 Kbps [15]. Table E.1 presents a comparison of widely used communication technologies for CN1 and CN2. The table elaborates two communication

Standard	Technology	Data rates	Frequency band
PLAN	PLC	200bit/s-2.4 kbps	CENELEC A
Meters&More	PLC	4.8-57.6kbpsn	CENELEC A, ARIB, FCC
PRIME	PLC	21.4-128.6kbps	CENELEC A
1901.2	PLC	Approx. 80 kbps	CENELEC A, ARIB, FCC
G.9902	PLC	Approx. 80 kbps	CENELEC A, ARIB, FCC
RF 1	RF Mesh	Approx. 4.8 kbps	444 MHz unlicensed ISM band
MeshNet3	RF Mesh	9.6 kbps	869.400-869.650 MHz

Table E.1: Examples of Communication Technologies for AMI in Europe [14]

technologies used namely, PLC based and Wireless RF mesh based technologies.

E.2.3 Conceptual Approach for Near Real-time SM Data Access for LV DSSE

In Section E.1, it is shown that the spare idle time has a limited capacity to collect relevant SM to be used by the DSSE. The number of relevant SMs accessed for this purpose is called R in this paper and the time it takes to collect them is referred as timeliness (Δt_R) which is shown in Fig. E.3. An assumption is made based on the existing measurement technologies. SMs measure electrical values together with a time logger which allows accessing data from specific time instants. Furthermore, for the analysis presented in Section E.3, variations of electrical parameters over time are not addressed either considered. This means, if the DSSE is executed using metering data with the timeliness of Δt_R seconds, the estimated states correspond to a time instant of Δt_R seconds in the past.

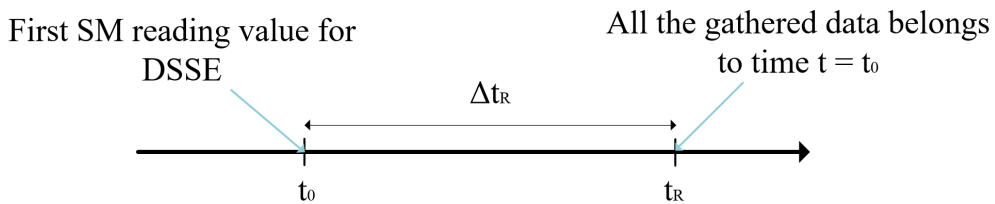

Fig. E.3: DSSE is executed with timeliness of Δt_R

The concept here is to support near real-time monitoring by utilizing the spare idle

time 1) to have DSSE performed with update rates flexible to the need of estimator 2) to minimize the timeliness of the relevant SM information within a DSSE execution cycle. To discuss the concept of having flexible DSSE update rates within spare idle time, this paper presents Access Scheme which is defined as the scheme of using the remaining idle time for reading selected SMs. Figure E.4 shows a conceptual system of three different Access Schemes proposed in this paper. In the figure, T_{rR} refers to the time allocated for reading relevant SMs:

Access Scheme 1: access strategy similar to the current AMI implementation where all SMs are read once in a cycle. Hence the DSSE is executed once every spare idle time, the number of relevant SMs could be increased as long as it is within the T_{rR} idle time bound. But accessing more SMs at the idle time comes at the cost of expanding the timeliness for the DSSE as having more SMs leads to longer reading time. The downside of this access strategy is that one cannot run DSSE during normal T_r reading time or fixed T_{imin} which makes it less optimal for event-triggered DSSE but works fine for periodic DSSE with slow update rate for the estimator.

Access Scheme 2: access strategy where idle time is used with an increased update rate of DSSE execution per reading cycle. From the shown example in the figure, DSSE is executed three times compared to one time in Access Scheme 1. Although there is a higher number of DSSE execution, this comes at the cost of having a shorter T_{rR} which makes it less flexible to increase the number of R per DSSE execution cycle. The advantage compared to Access Scheme 1 is that DSSE could be executed multiple times by selecting and scheduling different parts of the grid depending on the electrical behavior. Similar to Access Scheme 1 there is also a drawback if one wants to have an event triggered DSSE as it is not possible to execute DSSE during T_r and T_{imin} time.

Access Scheme 3: access strategy where DSSE could be scheduled to be executed at all times. T_r and T_{imin} are systematically divided in to slots to accommodate DSSE executions. The main advantage of having such kind of access scheme is its flexibility to support both periodic and event-triggered DSSE executions. For example, Fig. E.4 shows a scheme where DSSE runs at different three times at different time slots during the reading cycle. One can see that the main differing characteristics in Access Scheme 3 is that the time interval is much smaller than in Access Scheme 1, and distribution of time interval is more narrow than in Access Scheme 2 (where you have a kind of burst of DSSE execution followed by a long waiting time).

As mentioned before the second goal of near real-time AMI data access focuses on optimizing the timeliness of the relevant SMs information within a DSSE execution cycle. The discussion here focuses first on elaborating further on T_{rR} cycle, presenting contributing systems and subsystems involved. A system architecture for a two-layer AMI data access system is described as follows:

The SM can access a local measurement, which changes value over time. SMs provide electrical parameters or measurements as RMS voltages and currents, energy consumption, etc., per phase. The communication technology assumed in this work between

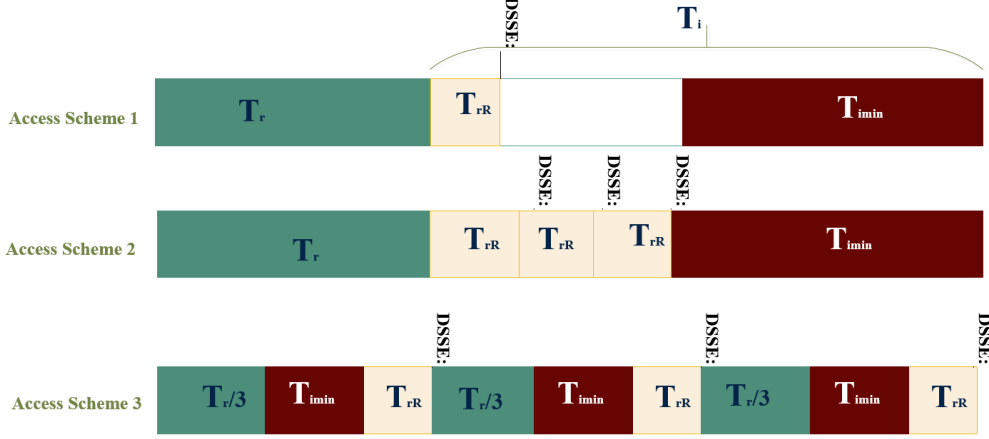

Fig. E.4: AMI Access Schemes

SMs and DCs is an RF mesh network. An RF mesh network is made up of SM nodes organized to make mesh topology. Mesh infrastructure transmits data over large distances by splitting the range into a series of short hops (Multi-hop), utilizing SM mesh nodes in each hop to route the data to a DC. The communication delay between the concentrator and SM is represented by D_1 , and the delay for communication between concentrator and head-end is represented by D_2 . The timeliness, Δt_R represents the maximum time of reading R relevant SMs within the allocated T_{rR} .

E.3 On the Trade-off Between Timeliness and DSSE Accuracy

E.3.1 Weighted Least Squared State Estimation

The WLS algorithm minimizes the function:

$$J(x) = \sum_{i=1}^m \frac{(z_i - h(x))^2}{R_{ii}} \quad (\text{E.1})$$

subject to $z_i = h(x) + r_i$

Where z is the measurements vector, $h(x)$ is a vector of equations relating the states x with the measurements z and R is the measurement errors covariance matrix. If the errors between measurements are assumed to be independent, then R is a diagonal matrix, which its inverse is referred to as W .

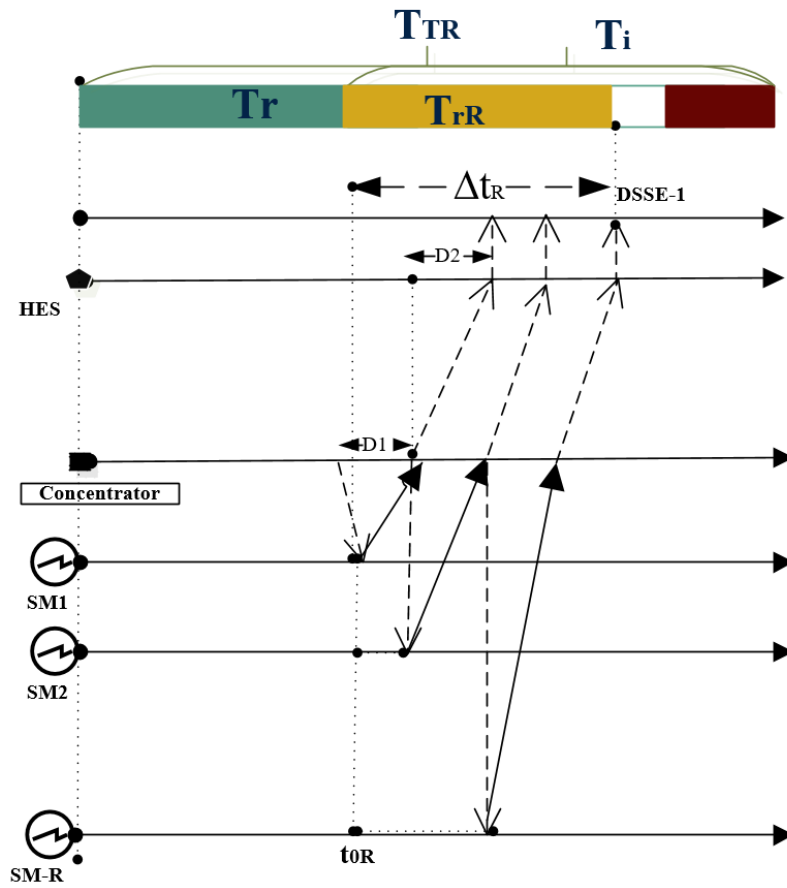

Fig. E.5: AMI Data Access System Characterization

Satisfying the first-order optimality conditions:

$$g(x) = \frac{J(x)}{\partial x} = -H^T(x)W[z - h(x)] = 0 \quad (\text{E.2})$$

where $H(x) = \left[\frac{\partial h(x)}{\partial x} \right]$

Using Taylor series expansion to linearize $g(x)$ around the state vector x^k (neglecting higher order terms) yields:

$$g(x) = g(x^k) + G(x^k)(x - x^k) = 0 \quad (\text{E.3})$$

The system above can be solved by the Gauss-Newton method in an iterative fashion:

$$\Delta x^{k+1} = G(x^k)^{-1}H(x^k)^T W[z - h(x^k)] \quad (\text{E.4})$$

$G(x)$ is known as the gain matrix of the system and equals:

$$G(x^k) = H(x^k)^T W H(x^k) \quad (\text{E.5})$$

The inverse of $G(\hat{x})$ is the covariance matrix of the estimated states [16]:

$$\hat{P}(x) = (H(\hat{x})^T W H(\hat{x}))^{-1} \quad (\text{E.6})$$

Generally, different types of input measurements can be used to form the vector z . Standard measurements are the nodal voltage magnitudes or phasors, branch current flow magnitudes or phasors, bus power injections or line power flows. The measurement function $h(x)$ is composed of equations relating the input measurements with the actual state variables. The way these equations are formulated is dependent on the utilized grid model. For example, two-port π -model for the grid branches [5], three-phase feeder model as in [17], etc., and the chosen state variables, i.e., nodal voltages or branch currents in polar or rectangular form. In this paper, the WLS SE methodology presented in [17] is approached where the estimated states are the voltage phasors at every node of the system expressed in rectangular form.

E.3.2 Evaluation Metrics

Two metrics are in the scope of evaluations in this paper, one linked to the timeliness of DSSE execution Δt_R , elaborated next and another for the evaluation parameter for the accuracy of DSSE is error covariance matrix explained further in section E.3.2.

Timeliness Metric

The time difference between a snapshot of data measurements to the time that the state estimation application delivers its estimation within the spare idle time is used as

a metric to validate timeliness. The selection of R SMs within T_{rR} affects the DSSE performance as each selection contains a different group of SMs from different feeders of the LV grid potentially leading to varying timeliness metric, Δt_R . To assess the impact of AMI access based on the system in Fig E.5. For R relevant SMs and deterministic D_1 and D_2 and sufficient idle time $T_{rR} < (T_i - T_{imin})$, the resulting Δt_R value is:

$$\Delta t_R = D_{11}/2 + \sum_{n=2}^R (D_{1n}) + D_2 \quad (\text{E.7})$$

Usage and Interpretation of Error Covariance Matrix

Let's consider the error covariance matrix as indicated in equat.E.8:

$$\hat{P} = (H^T(\hat{x})WH(\hat{x}))^{-1} \quad (\text{E.8})$$

As indicated in [16], since the measurement errors are assumed to be normally distributed a $\pm 3\sigma$ deviation around the mean covers more than 99.7% of the Gaussian curve. Therefore, an approach to calculate the measurement weights is:

$$\sigma_{zi}^{-2} = \left(\frac{\mu_{zi} \times \epsilon}{3 \times 100} \right)^{-2} \quad (\text{E.9})$$

where $\pm \epsilon$ is the maximum measurement error expressed as a percentage of the real value.

Note that μ_{zi} , which is the actual measurement, depends on the system operating scenario and the Gaussian error added by the measurement device. Therefore, the error covariance matrix of the estimated states built as defined until now is only valid for the estimates obtained given a set of measurements. However, quantifying the variances of the estimated states considering multiple operating scenarios can be achieved by calculating the expectation of the state error covariance matrix based on a large set of Monte Carlo simulations:

$$P_x = E[\hat{P}_x] \quad (\text{E.10})$$

Which is used for evaluation in the upcoming sections. Note that the largest of the diagonal entries in this matrix defines the estimated state which accuracy is the worst and thus, used as the accuracy metric in further analysis.

E.3.3 LV Grid Scenario

Figure E.6 shows the reference grid scenario used for the study in the paper. The model is representative of a real rural LV grid in Denmark [4]. Due to the nature of rural areas, households are scattered in large geographical areas which contributes to a smaller number of customers connected by longer feeders. In this case, the total

number of connected customers are 19, all of them equipped with a SM. Additionally, the secondary side of the substation is assumed to have a SM. Thus, the total number of SMs in the area is 20.

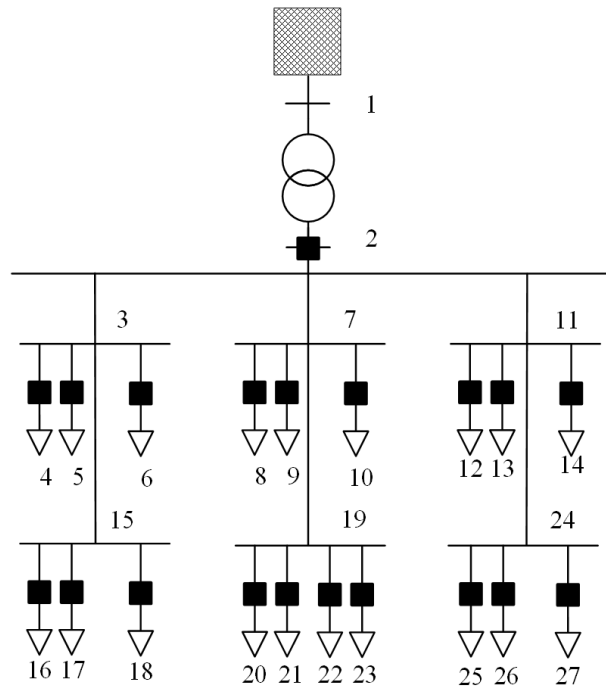

Fig. E.6: LV Grid Scenario, the black squares represent the position of the 20 SMs.

While it is straightforward to also add RES to this LV system, the grid operating scenarios in the analysis later provided, only consider consumption in order to delimit the parameter space.

E.3.4 AMI Scenario

To perform trade-off analysis between timeliness and accuracy for LV DSSE, three main cases shown in Table E.2 are chosen. For all cases, similar to the LV grid scenario, 20 SMs connected to single DC are considered. It is assumed that only single DC collects data from all SMs within the LV grid scenario in Fig. E.6. Note that a secondary substation can have up to some hundred customers connected to it; the motivation for selecting an LV grid with 20 SMs is 1) to have a computationally feasible scenario and 2) 20 selected SMs is realistic for real scenarios as well, as not all of the SMs are relevant for the DSSE.

1-hop		5-hop		het-hop		All cases	
Case 1	T_{rR}	Case 2	T_{rR}	Case 3	T_{rR}	T_{TR}	T_I
1.1	75s	2.1	375s	3.1	225s	1hr	24min
1.2	90s	2.2	450s	3.2	270s	1hr	24min
1.3	105s	2.3	525s	3.3	315s	1hr	24min
1.4	120s	2.4	600s	3.4	360s	1hr	24min
1.5	135s	2.5	675s	3.5	405s	1hr	24min
1.6	150s	2.6	750s	3.6	450s	1hr	24min
1.7	165s	2.7	825s	3.7	495s	1hr	24min
1.8	180s	2.8	900s	3.8	540s	1hr	24min
1.9	195s	2.9	975s	3.9	585s	1hr	24min
1.10	210s	2.10	1050s	3.10	630s	1hr	24min
1.11	225s	2.11	1125s	3.11	675s	1hr	24min

Table E.2: Communication topology scenarios, each table corresponds to a different meshed topology

The total reading time T_{TR} for each case is based on the round trip SM to DC delay, for N SMs, and providing enough idle time T_I as per the AMI functional requirement. Values for $D_1 = 10s$ and $D_2 = (1/4)s$ are motivated by RF mesh and 3G based networks at between SM and concentrator, and concentrator and headend, respectively [4]. Usually, these delays depend on the message sizes, and thus on the number of measurements to be transmitted, the assumption here is that the packets have fixed size leading to a constant delay. 1-hop and 5-hop scenarios represent best and worst AMI scenarios motivated by realistic AMI systems with meshed networks [4]. Table E.2 represent the selected cases for the investigation. The heterogeneous scenario is chosen in such a way that 20% of SMs are located at each hop from first to fifth.

E.3.5 Impact of Size of Selected Smart Meters on Timeliness

The analysis here helps to understand the relationship between an increasing number of relevant R SMs and timeliness Δt_R . The research question addressed here is, 1) for a given T_{rR} , what is the largest set of SMs to be accommodated and 2) how does the selection of SMs within T_{rR} affect Δt_R . To address this questions, varying T_{rR} values are chosen for each case in Table E.2. Through the study, we found all the possible combination of SMs fulfilling the T_{rR} requirement. The cases in Table E.2 give enough samples to understand and plot the relationship between R and Δt_R for each case fulfilling the T_{rR} requirement. For example cases 1.1 gives 77.520 different samples fulfilling the 75s requirement. Figure E.7 shows the relationship between R SMs and timeliness Δt_R . For the three cases shown, the figure shows maximum, minimum and average values of Δt_R for all possible set of combinations. The min, max and ave values for 1-hop and 5-hop cases are the same as expected; hence every R group of SM

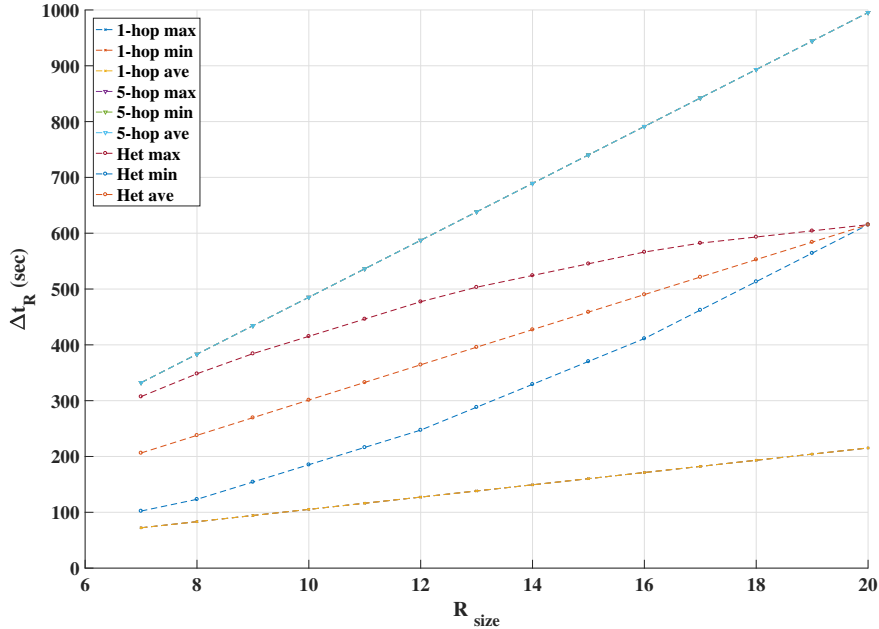

Fig. E.7: Relationship between number of relevant SMs and the resulting Δt_R for the three communication topology scenarios

gives the same Δt_R . The 5-hop values give higher Δt_R due to the added delay to transfer the message from SM to DC in multiple hops. Having 1-hop SMs is advantageous; hence the maximum number of SMs we could accommodate is more. To give an example for a given T_{rR} of 210, one can accommodate all the 20 first hop SMs but only five fifth hop SMs. The heterogenous hop case gives us a more realistic scenario where SMs are scattered in different hops. By running through all the possible combinations of SMs, we found the combination of SMs that give us the absolute minimum Δt_R for different R values. The analysis here is used in the next section to discuss the trade-off between Δt_R and estimation accuracy.

E.3.6 Analysis of Trade-off Between DSSE Accuracy and Timeliness

In this section, the relation between the accuracy of estimated states and timeliness of monitored data is studied. Active and reactive power pseudo-measurements are assumed to be available for each customer and modeled as Gaussian Mixtures Models (GMM)

providing the mean and variance of each of them [18]. Data collected from accessed SMs are the active and reactive powers as well as the voltage phasors. Over the measured value, the error in voltage measurements from SMs are $\pm 1\%$ and $\pm 3\%$ for active and reactive power measurements [19]. All smart metering measurements are considered available as instantaneous values provided at the beginning of the timeliness period.

The total number of SM combinations per size of vector R is large and subsequently, testing the accuracy for all possibilities becomes computationally unaffordable and unnecessary for this paper. Hence, a prioritization order of SM access is assumed in these studies. For instance, when increasing the number of accessed SMs from 8 to 9 (R_8 to R_9), the same 8 SMs as in R_8 are accessed, and only 1 new SM is added to the vector. Additionally, the prioritization order of SM access is random and providing prioritization criteria of SM access is out of the scope of this paper.

For simplicity reasons, balanced loading scenarios are considered, i.e., same power consumption in each phase of a given customer. Operating scenarios have been created by changing the loading conditions in each customer as the input data to a load-flow algorithm as in [20] and implemented in Matlab. Specifically, operating points of the system are created in a Monte Carlo fashion using the loading conditions defined by the Gauss curves of the pseudo-measurements.

Figure E.8 shows the largest of the state error covariance matrix diagonal entries, obtained when assuming that different number of relevant smart meters (R) are accessible via AMI. The states corresponding to the primary and secondary sides of the substation are excluded, since increasing the number of SMs improves the accuracy of the estimates of the node where it is placed and the adjacent junction box. The voltage measurements improve the accuracy of the node where those are placed while the measurement of power flowing between two nodes improve the accuracy of both [21], and thus the improvement of accuracy by increasing the smart metering data needs to be evaluated on the junction boxes and nodes of customers. Note that the variable defining the accuracy measure in axis y (obtained from the state error covariance matrix) in Fig. E.8, is given in per units since that is the unit defining the nodal voltages within the DSSE algorithm.

The number of Monte Carlo runs is set to 1000 and fixed for all sizes of the vector R , i.e., same Monte Carlo simulations are used from R_7 to R_{20} . Also, during the same Monte Carlo simulations, the WLS DSSE is executed, and its accuracy is also evaluated by the Root Mean Square Error (RMSE) as:

$$RMSE_{\hat{x}_i} = \sqrt{\frac{\sum_{n=1}^N (\hat{x}_i - x_i)^2}{N}} \quad (\text{E.11})$$

The accuracy values obtained by this approach are shown in Fig. E.9. The results validate the approach of evaluating estimates accuracy based on the expectation of the state error covariance matrices as introduced in Section E.3.2.

Furthermore, the accuracy of the DSSE measured by its RMSE is plotted together

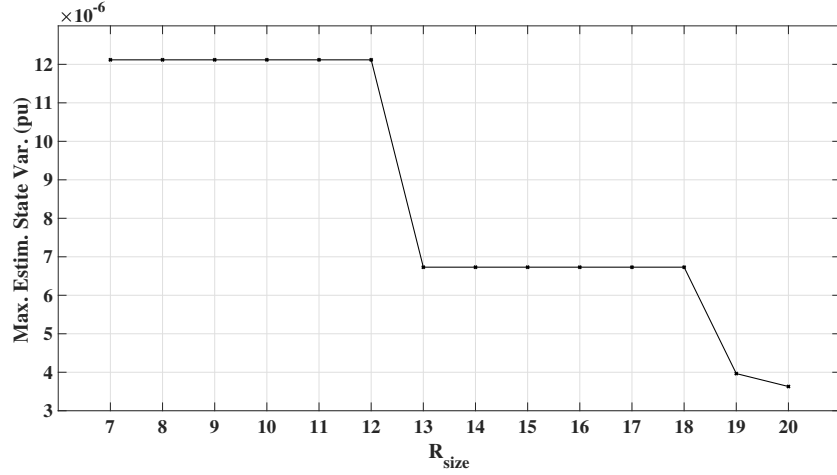

Fig. E.8: Largest estimated state variances from state error covariance matrix.

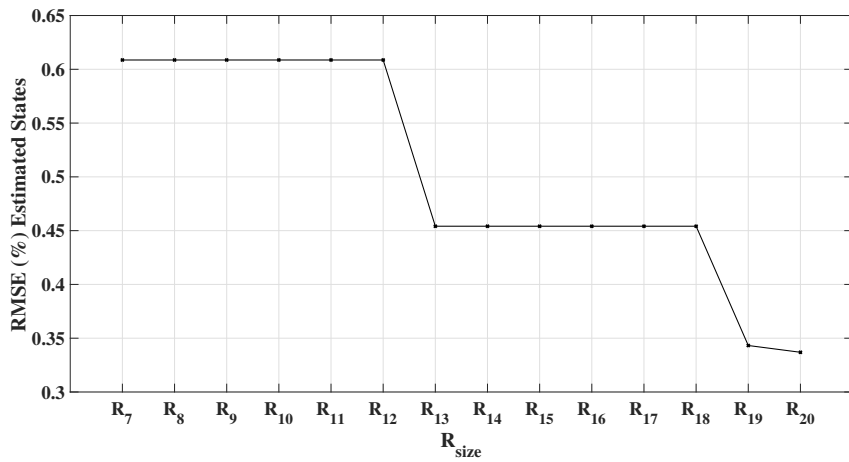

Fig. E.9: Largest state variance measured by its RMSE.

with the timeliness for the three cases from Section E.3.4. This is shown in Fig. E.10. Note that, the values shown in the plot are specific for the case under study but generally depend on:

- Followed criteria for SMs selection and prioritization which will be responsible for the accuracy improvement ratio over the different sizes of vector R . Prioritization

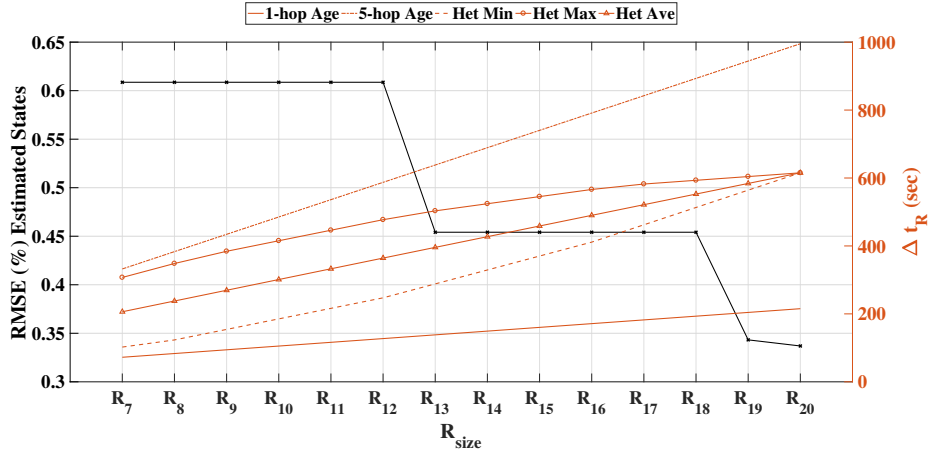

Fig. E.10: Analysis of the relationship DSSE accuracy vs. timeliness for different sizes of vector R.

and/or selection of SMs are not addressed in this paper.

- AMI topology is defining the increase of timeliness while increasing the number of accessed SMs.

Plotting the key performance indicators as depicted before allows to easily decide the selection of SM data considering monitoring constraints defined by maximum allocated reading time T_{rR} for relevant SMs. It also provides knowledge on the expected accuracy of final estimates. From Fig. E.10, one can see how the selection of SMs with timeliness Δt_R within T_{rR} allocated in Table E.2 affect DSSE quality. For example, if the allocated T_{rR} bound is 400, for the 1-hop scenario one can select all the 20 SMs obtaining the best DSSE accuracy. However, for the fifth hop scenario, with a similar T_{rR} bound of 400, only R=8 SMs can be chosen, which gives the worst DSSE quality seen in Fig. E.10. The accuracy of DSSE is affected by the number of accessed SMs, where the DSSE becomes less accurate with less number of SMs accessed due to communication constraints. For example, if the relevant SM nodes used for DSSE are located at geographically far distances from the concentrator, this affects the communication delay as it takes multiple hops to reach the concentrator and the R-value is also lower due to the long delays. The longer communication delays lead to an increased Δt_R which contributes to less timeliness of the data or lower estimation accuracy.

E.4 Conclusion and Outlook

SMs in current LV distribution grids can be used to support LV distribution system monitoring. However, due to the low bandwidth AMI communication technologies and a large amount of measuring points in LV grids, there are challenges to provide near real-time data access. The constrained AMI communication network contributes to the slow update of SM information with reading cycles of 6 hours and more. However, legacy SM reading cycles allocate idle times used for services such as firmware updates. Part of the idle time could be used to get measurements from selected SMs to support monitoring applications.

The concept of utilizing the spare idle periods for near real-time monitoring systems is approached from two main angles 1) to have DSSE performed with flexible and adaptive update rates and 2) to provide timely and accurate state estimates. The first approach is discussed by proposing and examining different access schemes. Due to the fast and unpredictable nature of active LV grids, the need for flexible and adaptive data access scheme is presented to support periodic and event-triggered monitoring strategies. Regarding the second point, a procedure to analyze the correlation between DSSE accuracy and timeliness of data for specific LV grids and AMI systems is proposed. The results show that few smart metering data provide fairly good state estimates accuracy results. Also, depending on the AMI topology, it might occur that having small improvements on accuracy come at the cost of large timeliness of data.

The discussion and results open doors for valid, future research problems such as:

- To design adaptive data collection mechanism supporting periodic and event driven monitoring.
- Perform a quantitative analysis which compares periodic and event driven strategies under the access schemes presented.
- To design smart meter selection and prioritization criteria supporting near real-time monitoring systems.

Acknowledgment

This work is financially supported by the Danish project RemoteGRID which is a ForsKEL program under Energinet.dk with grant agreement no. 2016-1-12399 and by the European Union's Horizon 2020 research and innovation program under grant agreement No 774145 within the project Net2DG. The authors would like to thank all project partners for their feedback and input.

References

- [1] A. Saint-Pierre and P. Mancarella, “Active distribution system management: a dual-horizon scheduling framework for dso/tso interface under uncertainty,” *IEEE Transactions on Smart Grid*, vol. 8, no. 5, pp. 2186–2197, 2017.
- [2] G. Pepermans, J. Driesen, D. Haeseldonck, R. Belmans, and W. haeseleer, “Distributed generation: definition, benefits and issues,” *Energy policy*, vol. 33, no. 6, pp. 787–798, 2005.
- [3] M. Stefan, J. G. Lopez, and R. L. Olsen, “Exploring the potential of modern advanced metering infrastructure in low-voltage grid monitoring systems,” in *2018 IEEE International Conference on Big Data (Big Data)*. IEEE, 2018, pp. 3543–3548.
- [4] Remotegrid. [Online]. Available: <http://www.remotegrid.dk/>
- [5] A. Gomez-Exposito and A. Abur, *Power system state estimation: theory and implementation*. CRC press, 2004.
- [6] F. C. Schweppe and J. Wildes, “Power system static-state estimation, part i: Exact model,” *IEEE Transactions on Power Apparatus and systems*, no. 1, pp. 120–125, 1970.
- [7] R. Sanchez, F. Iov, M. Kemal, M. Stefan, and R. Olsen, “Observability of low voltage grids: Actual dsos challenges and research questions,” in *2017 52nd International Universities Power Engineering Conference (UPEC)*. IEEE, 2017, pp. 1–6.
- [8] M. S. Kemal, R. L. Olsen, and H.-P. Schwefel, “Optimized scheduling of smart meter data access: A parametric study,” in *2018 IEEE International Conference on Communications, Control, and Computing Technologies for Smart Grids (SmartGridComm)*. IEEE, 2018, pp. 1–6.
- [9] K. Dehghanpour, Z. Wang, J. Wang, Y. Yuan, and F. Bu, “A survey on state estimation techniques and challenges in smart distribution systems,” *IEEE Transactions on Smart Grid*, vol. 10, no. 2, pp. 2312–2322, 2019.
- [10] A. Angioni, T. Schlösser, F. Ponci, and A. Monti, “Impact of pseudo-measurements from new power profiles on state estimation in low-voltage grids,” *IEEE Transactions on Instrumentation and Measurement*, vol. 65, no. 1, pp. 70–77, 2016.
- [11] A. Gómez-Expósito, C. Gómez-Quiles, and I. Džafić, “State estimation in two time scales for smart distribution systems,” *IEEE Transactions on Smart Grid*, vol. 6, no. 1, pp. 421–430, 2015.
- [12] M. Asprou and E. Kyriakides, “The effect of time-delayed measurements on a pmu-based state estimator,” in *2015 IEEE Eindhoven PowerTech*. IEEE, 2015, pp. 1–6.

- [13] K. Zhu, L. Nordström, and A. T. Al-Hammouri, "Examination of data delay and packet loss for wide-area monitoring and control systems," in *2012 IEEE International Energy Conference and Exhibition (ENERGYCON)*. IEEE, 2012, pp. 927–934.
- [14] S. Erlinghagen, B. Lichtensteiger, and J. Markard, "Smart meter communication standards in europe—a comparison," *Renewable and Sustainable Energy Reviews*, vol. 43, pp. 1249–1262, 2015.
- [15] M. Findrik, J. Groenbaek, and R. L. Olsen, "Scheduling data access in smart grid networks utilizing context information," in *2014 IEEE International Conference on Smart Grid Communications (SmartGridComm)*. IEEE, 2014, pp. 302–307.
- [16] R. Singh, B. C. Pal, and R. B. Vinter, "Measurement placement in distribution system state estimation," *IEEE Transactions on Power Systems*, vol. 24, no. 2, pp. 668–675, 2009.
- [17] C. Lu, J. Teng, and W.-H. Liu, "Distribution system state estimation," *IEEE Transactions on Power systems*, vol. 10, no. 1, pp. 229–240, 1995.
- [18] R. Singh, B. Pal, and R. Jabr, "Distribution system state estimation through gaussian mixture model of the load as pseudo-measurement," *IET generation, transmission & distribution*, vol. 4, no. 1, pp. 50–59, 2010.
- [19] M. Pau, P. A. Pegoraro, and S. Sulis, "Efficient branch-current-based distribution system state estimation including synchronized measurements," *IEEE Transactions on Instrumentation and Measurement*, vol. 62, no. 9, pp. 2419–2429, 2013.
- [20] R. M. Ciric, A. P. Feltrin, and L. F. Ochoa, "Power flow in four-wire distribution networks-general approach," *IEEE Transactions on Power Systems*, vol. 18, no. 4, pp. 1283–1290, 2003.
- [21] M. Asprou and E. Kyriakides, "Optimal pmu placement for improving hybrid state estimator accuracy," in *2011 IEEE Trondheim PowerTech*. IEEE, 2011, pp. 1–7.

Biography



Mohammed Kemal received his B.Sc degree in Electrical, Electronics and Communications Engineering from Jimma University, Ethiopia and M.Sc degree in Network and Distributed Systems from Aalborg University, Denmark in 2008 and 2014, respectively. From 2008 to 2012, he was working as a Telecom Engineer at Crescent Engineering and IT Solutions, Ethiopia. Where he was responsible for the design, installation, and monitoring of network and communication systems for multipurpose industrial infrastructures. In 2015, He has worked a Scientific Assistant at Department of Energy and Technology Aalborg University. Starting from 2016 he is pursuing his Ph.D. in the area of real-time monitoring of distribution grids using adaptive data collection of SM data at Department of Electronics of Aalborg University, Denmark.



Ruben Sanchez received his B.Sc degree in Industrial Technical Engineering, specialization in Industrial Electronics from Alcala University, Spain and M.Sc degree in Power Electronics and Drives from Aalborg University, Denmark in 2014 and 2016, respectively. Starting from 2016 he is pursuing his Ph.D. in the area of real-time monitoring of low voltage distribution grids using smart metering data at Department of Energy Technology of Aalborg University, Denmark.



Rasmus Løvenstein Olsen is an Associate Professor at Aalborg University working in the Wireless Communication Networks (WCN) group. Rasmus received his master degree from Aalborg University in 2003 and has received his PhD degree on the topic of Context Sensitive Service Discovery and Context Management with focus on access to dynamic information in 2008. Rasmus' current research focus is on the role of communication networks in smart grid and the impact of networks on remote access to dynamic data of the collection as well as the distribution of information. He is a member of several IEEE technical program committee and is currently active in the electrical association of Intelligent Energy in Denmark and been local chair for SmartGridComm 2018. He is currently engaged in national and European research smart grid projects; Net2DG, and WP leader in EU FP7 SmartC2Net on Experimental Prototypes. Rasmus is currently technical coordinator of the ForskEL (Energinet.dk) smart grid project RemoteGRID.



Florin Iov (S '98, M '04, SM '06) received the Dipl. Eng. degree in electrical engineering from Brasov University, Romania, in 1993 and a PhD degree from Galati University, Romania in 2003 with a special focus in the modeling, simulation and control of large wind turbines. He was staff member at Galati University, Romania from 1993 to 2001. Dr. Iov was with Institute of Energy Technology, Aalborg University, Denmark between 2001 and 2009 where he was mainly involved in research projects regarding wind turbines and wind power systems. From 2010 to 2012 he held a position as Power System Research Specialist in VestasWind Systems working with new ancillary services for augmented wind power plants. Since 2013 Dr. Iov is with Institute of Energy Technology focusing on research within smart grids.



Hans-Peter Schwefel is Professor for Communication Networks at Aalborg University, Denmark, and managing director of the startup company GridData (www.griddata.eu). In parallel to his position at Aalborg University, he has previously been Scientific Director of the Research Center for Telecommunications (Forschungszentrum Telekommunikation Wien - FTW) in Vienna, Austria in 2008-2016. His research focuses on IPbased communication networks and their applications for critical infrastructures with main interest in performance and dependability aspects. Before he joined Aalborg University, he was a project manager at Siemens Information and Communication Mobile, supervising research projects and responsible for the development of technical concepts for next generation mobile networks. He obtained his doctoral degree in the area of IP traffic and performance modeling from the Technical University in Munich, Germany.

Paper F

Model-Free Detection of Cyberattacks on Voltage Control in
Distribution Grids

Mohammed S. Kemal, Wissam Aoudi, Rasmus L. Olsen and Magnus
Almgren

The paper is submitted for publication in the
EDCC 2019, 2019.

© 2019 EDCC
The layout has been revised.

Abstract

Incorporating information and communication technology in the operation of the electricity grid is undoubtedly contributing to a more cost-efficient, controllable, and flexible power grid. Although this technology is promoting flexibility and convenience, its integration with the electricity grid is rendering this critical infrastructure inherently vulnerable to cyberattacks that have potential to cause large-scale and far-reaching damage. In light of the growing need for a resilient smart grid, developing suitable security mechanisms has become a pressing matter. In this work, we investigate the effectiveness of a model-free state-of-the-art attack-detection method recently proposed by the cybersecurity community in detecting various common types of cyberattacks on voltage control in distribution grids. Experimental results show that, by monitoring raw controller and smart-meter data in real time, it is possible to detect common cyberattacks such as denial of service, replay, and integrity attacks, thus contributing to a resilient and more secure grid.

F.1 Introduction

Due to limitations, costs, and growing concerns over environmental impact of the electricity grid, transitioning into the envisioned cost-effective, more environment-friendly, highly manageable and controllable *smart grid* has become increasingly pressing over the past few years. Advances in information and communication technology—the driving force behind this transition—are paving the way for a more flexible distribution grid capable of resolving the limitations of the current electricity grid and optimizing the integration of renewable energy sources, such as wind and solar power. The other side of the coin, however, is that the integration of communication technologies makes the smart grid susceptible to cyberattacks capable of causing serious damage to the electricity infrastructure.

The successful operation of smart grid services, such as monitoring and control of low-voltage distribution grids (LV-grids), demand management, energy theft detection and load forecasting [1], relies heavily on fine-grained smart meter readings. The transmission of such sensitive data over insecure communication links, however, goes beyond privacy issues and opens doors to malicious actors to compromise the grid operation via cyberattacks that could cause, for instance, a massive operational failure of energy assets [2].

In light of the expanding threat surface in energy networks, the ability to detect cyberattacks before they cross from the cyber realm to the physical world is growingly needed. In this paper, we investigate the effectiveness of PASAD, a recently proposed model-free technique for detecting attacks on industrial control systems, in detecting various common types of cyberattacks on LV-grids. PASAD captures the dynamics of voltage-control loops during a training phase through sophisticated analysis of time series of controller and smart-meter data, then detects deviations from the normal behavior through real-time data processing.

The motivation behind using a model-free detection approach in current LV grids is twofold. First, the data required for modelling current distribution grids is scarce and inaccurate. This makes model-based techniques difficult to apply since they require correlating measurements with a model of the LV grid. Second, a model-free approach is inherently agnostic to the controller scenario and can thus be used for different kinds of control, independently of the underlying LV grid.

Control of photo-voltaic (PV) and small-scale wind turbines in electricity distribution grids is growingly adopted to address challenges arising from the recent proliferation of distributed generation units. The voltage-control scenario under study in this paper targets reduction of over- and under-voltages by adjusting reactive power generation of selected low-voltage grid assets. The proposed approach is validated through a series of experiments using a low-voltage grid model based on a single-phase representation of a realistic LV grid in Denmark. Experimental results using various representative low-voltage control scenarios demonstrate a promising capability of detecting subtle attack-induced changes in the system behavior.

The remainder of this paper is laid out as follows: In Section F.2, we present background material and discuss related work. Section F.3 describes the system architecture and Section F.4 introduces the attack scenarios and illustrates the attacker model. The attack-detection methodology is presented in Section F.5 and the proposed approach is evaluated in Section F.6. Finally, we conclude this work in Section F.7.

F.2 Background

F.2.1 Low-Voltage Distribution Grids

The operation of future LV-grids typically involves the control and coordination of distributed renewable generation and consumption units, collectively referred to as *controllable assets*. In particular, wind turbines and PV systems scattered throughout distribution networks exchange system states with the controller [3, 4].

Figure F.1 outlines a conceptual control loop together with a high-level description of the information flow in a typical voltage-control scenario in an LV-grid. Sensors measuring the grid state communicate their measurements via smart meters (SMs) to a voltage controller over a communication network that is necessarily fast and reliable to optimize the use of controllable assets [5, 6]. Based on a predefined control objective, the controller then utilizes the received grid state information to make decisions on how actuators in the grid should operate; for example, calculating new set-points for PV systems or energy storage.

The voltage control implementation used in this work is event-driven. In an event-driven control setting, the control loop is triggered upon violation of certain control criteria. In the event of such a breach, the controller starts executing periodically until the grid satisfies the control criteria. In an attempt to minimize the potential economic

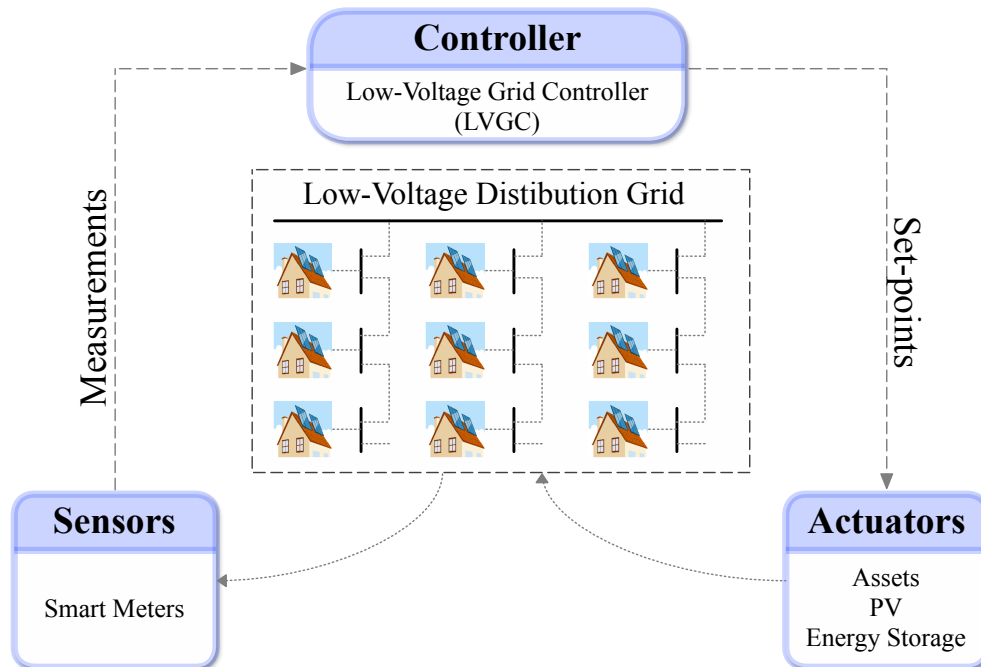

Fig. F.1: A conceptual control loop for maintaining low-voltage grids within the operational bounds.

implications of prolonged continuous control, the event-driven controller remains idle for as long as possible.

F.2.2 Related Work

LV grids are witnessing a rapidly increasing integration of distributed inverter-based generation. Although the distributed generation units may contribute to voltage problems, such as over-voltages, harmonics, dips, and swells, they could also be leveraged to solve the very same problems. In an increasingly common control situation, inverters participate in intelligent grid controls to solve the voltage problems [7, 8].

[9] discuss measurement falsification scenarios, wherein an adversary corrupts voltage measurements received by so-called voltage droop controllers, and assess the impact of such attacks on system stability and voltage magnitude using analytical control-theoretic methods. Using a rather simple grid model, the authors focus only on the effects of such attacks on the controllers and do not investigate attack detection.

In [10, 11], so-called cyber-secure modeling frameworks for the power grid and

the communication networks are discussed. [11] consider general smart-grid scenarios, whereas [10] explicitly propose an intelligent distributed secure control architecture for distribution systems to provide greater adaptive protection through proactive reconfiguration and rapid response to disturbances. In both works, however, the impact and detection of cyberattacks are not addressed.

[12] propose a detection algorithm for centralized voltage regulation, whereby voltage measurements from sectioning switches equipped with sensors feeding to a centralized controller are monitored to detect attacks that are performed at the controller level only.

To our knowledge, our work is the first that studies the consequences of cyberattacks on voltage control in LV distribution grids and that proposes a model-free approach to detecting such attacks on both the controller side and the actuators side.

F.3 System Description

The layout and architecture of the reference LV-grid used to validate our proposed approach are presented in Fig. F.2. In the setup shown therein, local measurements of voltage and total power on the LV bus bar are accessed by a low-voltage grid controller (LVGC) assumed to be located in a secondary substation. The three nodes highlighted in green represent the controllable assets used in our evaluation, which consist of PV systems equipped with energy storage capabilities.

Sensors mounted on the controllable assets measure the local voltage for the controllable assets, as well as the minimum and maximum active and reactive power, and communicate with smart meters to notify the controller in the event of a threshold violation. To keep the voltages within operational bounds, the controller communicates set-points to the controllable assets.

The reference grid is simulated using the Matlab-based tool DiSC, which is an open-source simulation framework originally developed to verify voltage-control approaches in European power distribution systems [13]. In order to reproduce realistic dynamics in the reference grid, in addition to simulating household consumption patterns for each node in the grid, some of the nodes are equipped with PV systems and storage elements, thereby adding more variability to the voltage behaviour. This variability is demonstrated in Fig. F.3, which shows a sample voltage behavior of two nodes with and without PV systems.

For the purpose of this work, we use a generalized event-driven voltage-control strategy wherein the controller starts executing whenever voltage measurements at the asset nodes violate a prespecified threshold. The LVGC controls the behavior of the reactive power by communicating control signals (set-points) to the controllable assets. Upon a threshold violation, the voltage controller runs every 2 minutes and sends set-points to the controllable assets in the grid until the voltage recovers the normal level. The control for each individual asset is a droop control changing solely the reactive power according to the equation $Q_{ref}(t) = G_D \times (1 - |V_{OutAssets}(t)|/V_{base})$, where $V_{OutAssets}(t)$

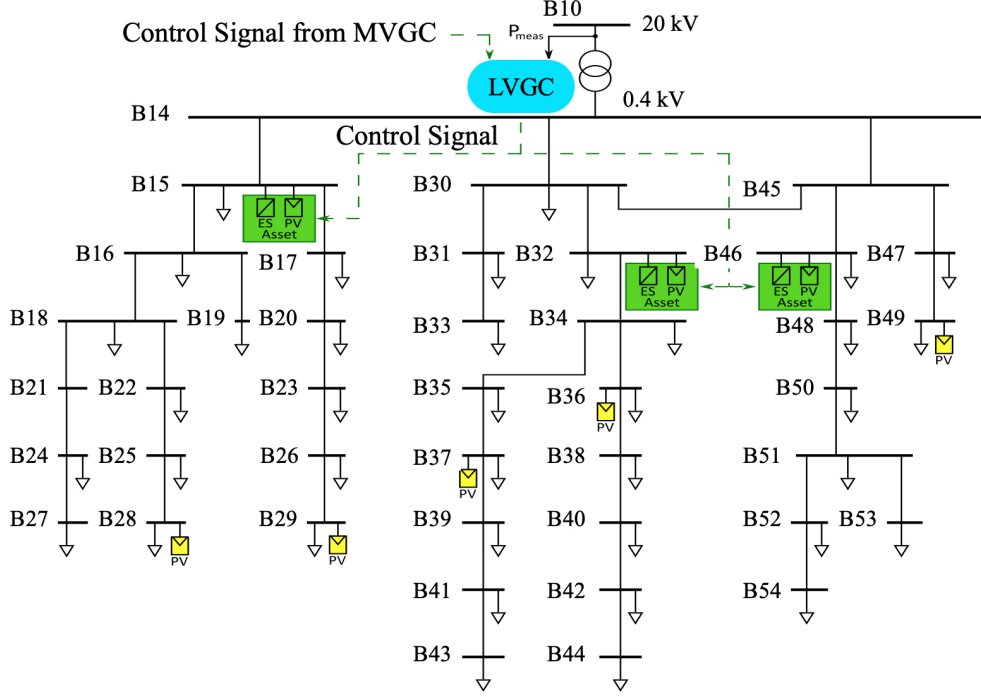

Fig. F.2: Layout and architecture of the reference LV-grid used in this work. The nodes in green boxes are controllable assets [6].

is the measured asset's voltage at time t , V_{base} is the nominal voltage, and G_D is the droop gain obtained by manual tuning of the controller. Although it processes local information for control, the use of a centralized controller is motivated by the possible coordination of assets in reaching a global objective [8].

F.4 Adversary Model and Attack Scenarios

Previous studies have shown that many existing smart meters lack the necessary means of ensuring data integrity and authenticity [14, 15]. Although the damage inflicted by compromising a few smart meters and causing voltage fluctuations may be limited to household equipment, an attacker taking control of a sufficiently large subset of smart meters may be able to destabilize the entire infrastructure, potentially leading to nothing less than a blackout.

The adversary model assumed in this work is presented in Fig. F.4. The voltage-control loop is exploitable by an adversary whose objective is to destabilize the distribution grid. Due to the closed-loop structure, small malicious modifications to the control signals can be iteratively amplified by the control loop, causing an increased violation of voltage thresholds, drainage of energy storage, and increased system operating cost.

As shown in Fig. F.4, on the one hand, the adversary can manipulate the control signals q_{ref} by either compromising the communication link between the controller and the controllable assets or by directly compromising the controller, in which case the assets would execute malicious signals sent by the adversary. On the other hand, the adversary may compromise the smart meters and manipulate the $v_{OutAssets}$ readings transmitted to the controller, so that the latter reacts erroneously.

We consider three common attack types, namely, denial of service, replay, and integrity attacks. Following is a description of the attack scenarios considered in this work.

Denial of Service Attack. In an event-based voltage-control setting, the integration of computing systems, communication networks, and physical electric power systems gives rise to a multi-dimensional and heterogeneous complex environment with real-time sensing, dynamic control, and information services. A Denial of Service (DoS) attack is a resource-exhausting attack that effectively suspends the control of the system in an attempt to bring it to an unsafe state. A DoS attack is launched by attackers whose aim is to cause lack of service availability, e.g., a power outage affecting customers and distribution system operators alike.

For a distribution grid with a networked control system, DoS attacks can take many

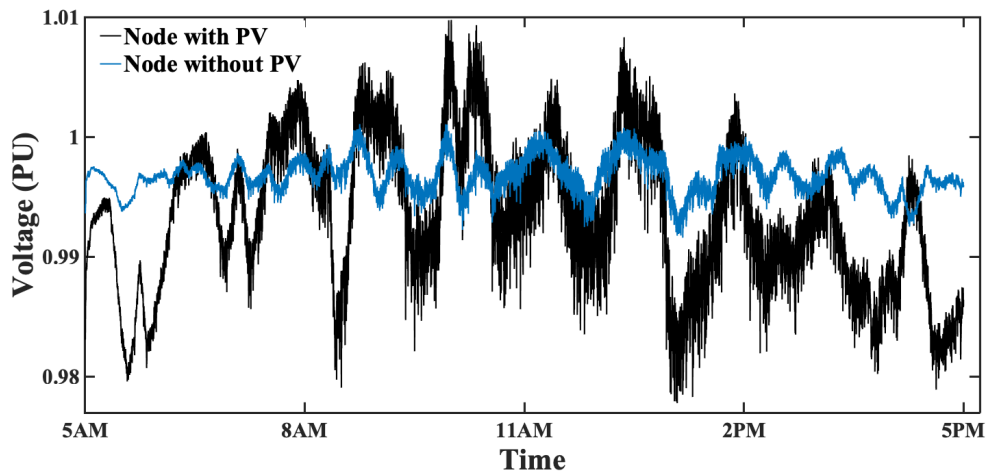

Fig. F.3: The dynamics of voltage behavior for two nodes with and without PV systems.

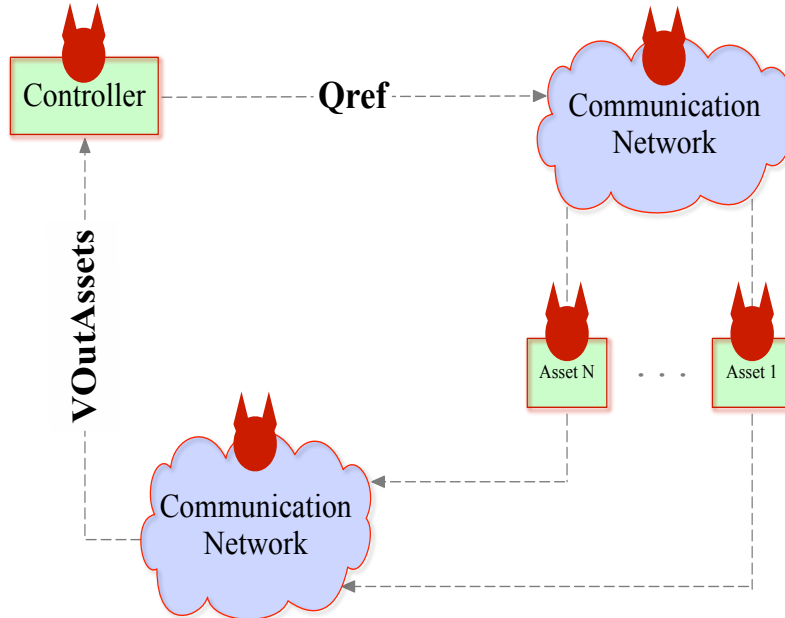

Fig. F.4: The adversary model.

forms [16]. For instance, the attacker can flood the communication network with useless requests to exhaust the network resources and thus suspend the exchange of messages carrying control signals. Alternatively, attackers who manage to compromise the controller entirely may block access to the communication channel or completely switch off the controller.

Replay Attack. In a replay attack, the adversary replays previously recorded traffic in an attempt to fool the controller. As discussed in [17], a successful replay attack initially involves collecting and passively recording sequences of data by manipulating the controller, the communication network, or the smart-meter measurements. The previously recorded data sequences are subsequently replayed onto the network during a desired time interval. A successful replay attack does not require prior knowledge of the system components.

Integrity Attack. We consider integrity attacks on the control signals sent by the controller to the controllable assets. In an integrity attack, the Q_{ref} control signal is maliciously manipulated by the adversary so that the set-point in the current control loop received by the asset differs from the true set-point sent by the controller. Unlike replay attacks,

integrity attacks require extensive domain-knowledge of the components and operation of the target system. Specifically, conducting an integrity attack requires the adversary to be capable of modifying the controller data at the controller, during transmission, or at the smart meters.

Integrity attacks on control signals can be performed in different ways by exploiting known vulnerabilities [15]. For instance, by compromising intermediate nodes in the communication network of the power grid (e.g., routers), an attacker can intercept and forge network packets carrying q_{ref} signals so that they contain maliciously altered set-points.

F.5 Attack Detection Methodology

To detect the simulated attacks on the LV-grid described in Section F.3, we apply a Process-Aware Stealthy-Attack Detection mechanism (PASAD) that has recently been proposed by [18] to detect attacks on industrial control systems. The method takes as input a time series of process measurements and raises an alarm whenever a change in system dynamics is suspected.

PASAD works in two phases: an offline training phase and an online detection phase. In the training phase, the normal behavior of the underlying dynamical system is represented mathematically in a low-dimensional *signal subspace* by means of spectral decomposition of a special matrix derived from the time-series data. Afterwards, during the detection phase, the most recent process measurements are compared to the normal behavior established in the training phase to determine whether or not a structural attack-indicating change in behavior is taking place. This is done by computing a *departure score* for every new measurement to determine the extent to which current readings conform to the estimated dynamics. Finally, an alarm is raised whenever the computed score crosses a certain threshold determined during a validation period.

We run two concurrent instances of PASAD to monitor the two different time series of process data that exist in the control loop (see Fig. F.4): smart meter voltage measurements $v_{\text{OutAssets}}$ and controller set-points q_{ref} . For each of the two instances, an initial subseries of the measurements time series is used to construct a so-called *trajectory matrix* \mathbf{X} . Then, a subset of the eigenvalues of the covariance matrix $\mathbf{X}\mathbf{X}^T$, obtained from the *singular value decomposition* of \mathbf{X} , is selected to form a basis for the low-dimensional signal subspace. When vectors constructed out of the time series of measurements are projected onto the signal subspace, the following phenomenon occurs: under normal operating conditions, the projected vectors occupy a bounded region and thereby form a cluster, whereas under attack conditions, the vectors *depart* from the cluster. To measure this departure, a departure score is computed for the most recent test vector to determine the distance from the cluster.

A succinct depiction of the workings of PASAD is presented in Fig. F.5. The time series shown in the left plot is an artificial square wave with added white Gaussian noise.

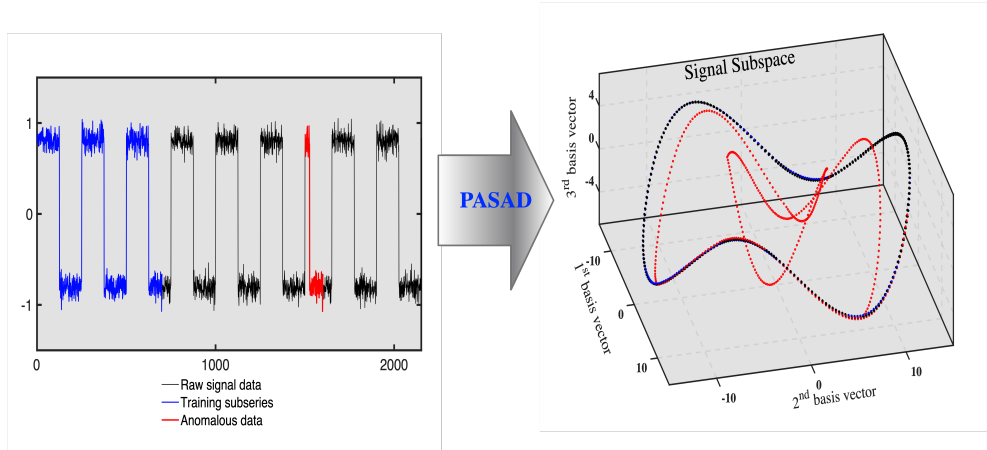

Fig. F.5: A visual demonstration of how PASAD detect anomalies in time-series data. The left plot shows the original input signal (e.g., raw sensor measurements). As shown in the right plot, PASAD transforms the signal data into a geometric space wherein anomalous behavior (highlighted in red) is easier to detect.

During the training phase, PASAD processes an initial part of the time series to learn about the underlying signal by identifying a mapping from the input space to a so-called signal subspace as shown in the right plot. The mapping is an orthogonal projection that transforms the time-series measurements into vectors in a low-dimensional vector space in which consecutive training vectors follow a pattern, thereby establishing a baseline of normal system behavior. During the testing phase, PASAD continuously checks if the most recent test vectors conform to the pattern. In the event of a structural change in the time series, as shown in the figure, the test vectors break out of the pattern indicating an anomalous behavior.

For a comprehensive treatment of the underlying theory and parameters setting, the reader may refer to [18].

F.6 Evaluation

In this section, we introduce the experimental setup, followed by a description of the experiments corresponding to the three attack scenarios introduced in Section F.4.

For all the experiments, the upper subplot displays the time series of process measurements monitored by PASAD comprising five days of operation. The initial subseries highlighted in blue was used for training and estimating the signal subspace. In all cases, the attack takes place on the fifth day at noon and lasts for two hours. The measure-

ments during the attack interval are highlighted in red. The lower subplot shows the departure scores computed iteratively by PASAD for every new measurement, together with the alarm threshold. The threshold was determined by running PASAD for a validation period of 24 hours and then selecting the maximum value attained plus a relatively small constant. For each attack scenario, two experiments were conducted: one where q_{ref} was monitored and another where $v_{\text{OutAssets}}$ was monitored. For the sake of producing difficult attack cases, the simulation was performed during summer days, where the attacks occurred at lunchtime, which is the time when the controller is most active due to the unpredictable stochastic behavior of the PV systems induced by solar irradiance.

F.6.1 Experimental Setup

The LV-grid simulation model used in our experiments is an extrapolation of an actual LV-grid in northern Denmark. The simulated grid comprises 37 housing units with integrated heat pumps (see Fig. F.2) among which 8 units have uncontrollable PV systems and 3 units have controllable PV systems combined with energy storage (battery). The simulated household consumption patterns are based on real consumption models. The behavior of the PV systems is generated by models incorporating solar irradiance, geographical location, cloud cover, and time of the day [6, 13, 19].

For the experiments performed in this work, the threshold bounds are $1 \pm 0.013pu$ for identifying voltage violations and $1 \pm 0.01pu$ for activating the controller. The controller activation bounds are narrower to give the controller time in advance of the voltage violation. Furthermore, these bounds were chosen to be relatively small in order to activate the controller more frequently. Regarding the droop control, the single-phase nominal voltage V_{base} is set to 400V, and the droop gain (G_D) is chosen to be $2 \times 10^5 \text{VAR/V}$ in the experiments based on manual tuning of the controller. The parameters of the LV-grid, asset models, and the generalized event-driven controller are summarized in Table F.1.

F.6.2 The DoS Attack Experiment

To perform the DoS attack, we assume that the attacker compromises the control center and switches off the controller for two hours, which, according to the simulation model used in this work, causes the control signals (q_{ref}) to go to zero during the attack. The detection results of this attack are displayed in Fig. F.6 and Fig. F.7. As shown in the figures, the attack was detected by PASAD in both q_{ref} and $v_{\text{OutAssets}}$.

F.6.3 The Replay Attack Experiment

For the replay attack scenario, the attacker is assumed to have the means to passively record q_{ref} control signals transmitted by the controller towards the sensor at the as-

set side. This can be achieved by compromising the wireless communication channel between the sensor and the controller or by gaining full access to the sensor interface. The recording occurs during morning time from 10AM to 11AM. The recorded traffic is subsequently replayed by the attacker during lunchtime from 12PM to 2PM. Both the recording and replaying occurred on the fifth day of operation. The results of this experiment are displayed in Fig. F.8 (for q_{ref}) and Fig. F.9 (for $v_{\text{OutAssets}}$). As can be seen in the figures, PASAD successfully detects the replay attack at both ends of the control loop.

F.6.4 The Integrity Attack Experiment

To simulate an integrity attack on LV-grids, we assume that the attacker, by compromising the communication link, forges the set-points sent by the controller to the controllable assets. Specifically, the attacker alters the control signals in such a way that they perform the opposite function, i.e., injecting instead of consuming reactive power or consuming instead of injecting reactive power, where the latter is the case in this experiment. As in the previous scenarios, the attack was detected in both the control signals and the sensor measurements as shown in Fig. F.10 and Fig. F.11 respectively.

F.6.5 Discussion

As the experimental results show, cyberattacks on LV-grids can be detected using a lightweight data-driven approach that obviates the need for building complex models and predicting future grid states. Due to the closed-loop mechanism, attacks on the controller manifest structural changes in the smart-meter readings. In all test cases,

Table F.1: Reference Grid Parameters

Parameter	Value
Number of electrical nodes	49
Number of buses	42
LV base voltage	400V
PV max rated power	6kW
PV efficiency	20%
PV area	28m ²
Energy storage capacity	65kWh
Energy storage rated power output	10kW
Summer simulation day	June 9
Winter simulation day	February 2
Geographical latitude	56,889°

PASAD managed to detect the attacks at both ends of the controller. Note that in some cases (DoS and Integrity attacks), the controller does not recover the normal behavior completely, which explains the second spike in the departure scores after the

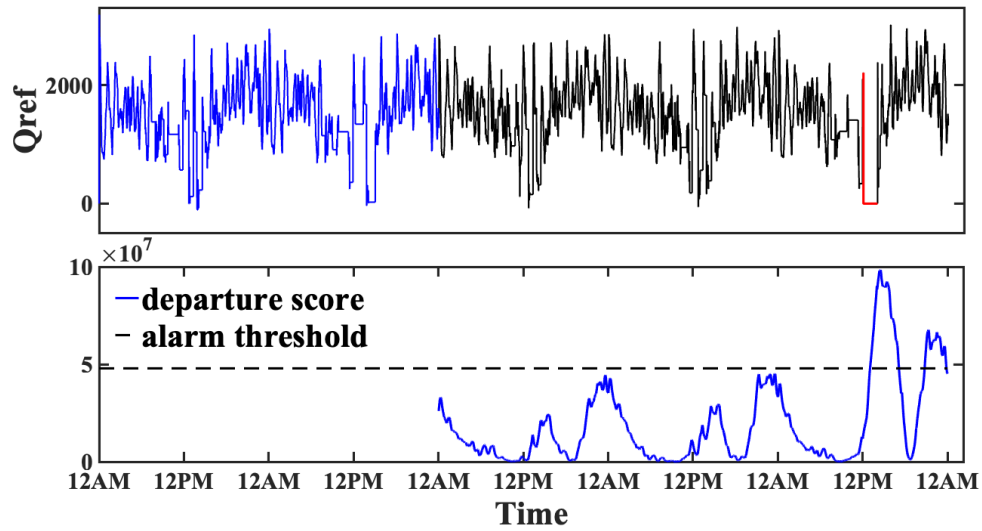

Fig. F.6: DoS attack on set-points (Q_{ref}).

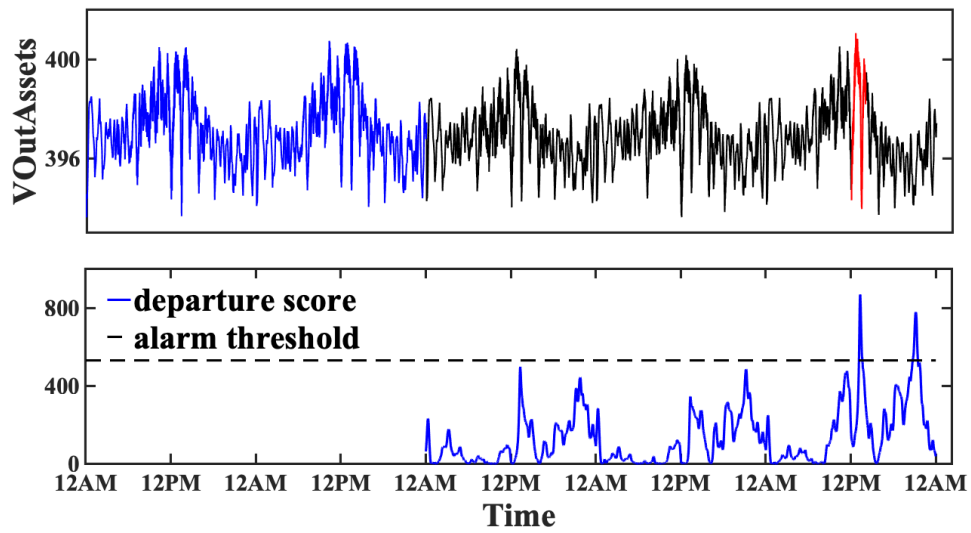

Fig. F.7: DoS attack on measurements ($V_{OutAssets}$).

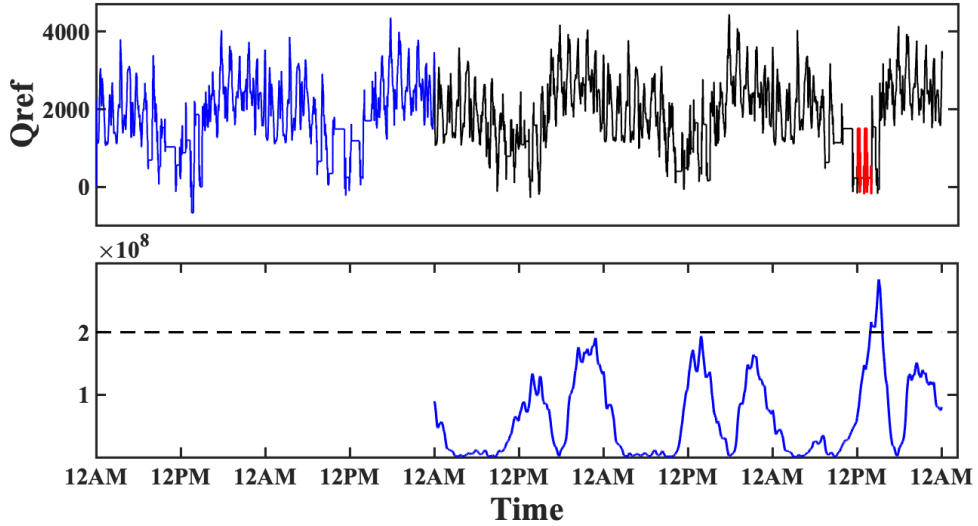

Fig. F.8: Replay attack on set-points (Q_{ref}).

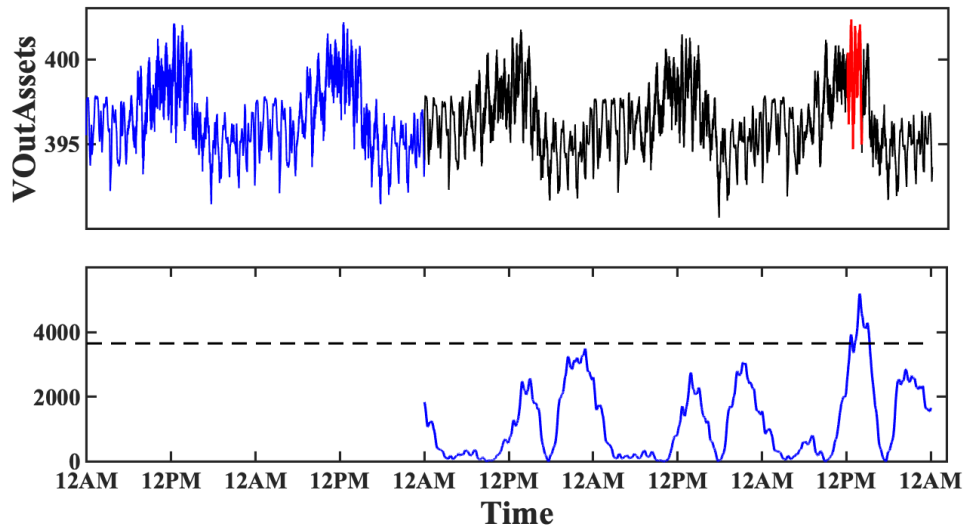

Fig. F.9: Replay attack on measurements ($V_{OutAssets}$).

attack onset. Also, it should be pointed out that in the integrity attack scenario, although the controller exhibits an implausible behavior (Fig. F.10), it is possible for a strategic adversary to spoof the control signals while carrying out the attack. However,

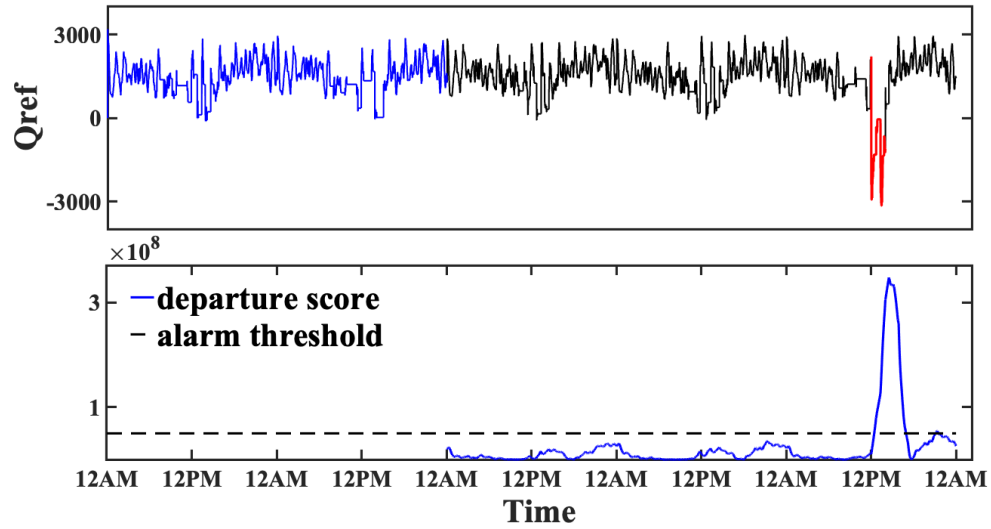

Fig. F.10: Integrity attack on set-points (Q_{ref}).

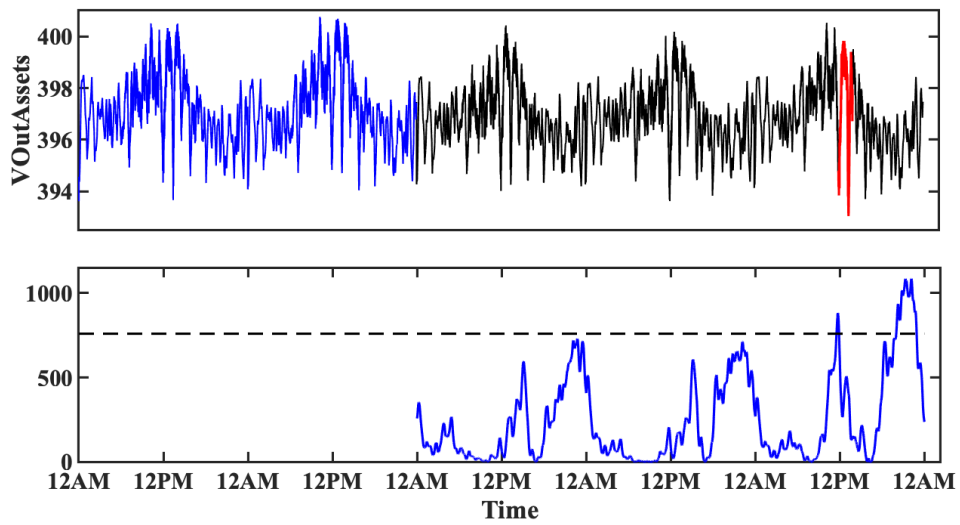

Fig. F.11: Integrity attack on measurements ($V_{OutAssets}$).

as demonstrated in Fig. F.11, the attack can still be detected at the other end of the control loop.

F.7 Conclusion

The current electricity grid appears to be taking steady steps towards the more efficient, modernized smart grid, with substantial integration of information and communication technologies seeming inevitable in the process. Being a critical infrastructure, securing the grid against cyberattacks proves necessary. In particular, a likely consequence of cyberattacks on the LV-grid is the contamination of measurements collected from compromised nodes, which in turn leads to bad control decisions by the controller. If a proper attack-detection mechanism is in place, compromised assets can be excluded by the controller when making control decisions.

In this paper, we proposed a systematic approach to detecting cyberattacks on voltage control in LV-grids by monitoring time series of process data. Experimental results show that various common types of cyberattacks (DoS, replay, integrity) on LV-grids can be successfully detected using a model-free data-driven approach that does not require building complex models of the underlying system.

Although our analysis and results were based a single grid scenario in Denmark, the grid model used in our experiments features a high integration of renewable units and incorporates real household consumption measurements, thus contributing to richer dynamics. It is therefore likely that the proposed approach is applicable to most grid models that involve less integration of renewable units.

As we have shown in this work, monitoring control signals and voltage measurements both at the controller's side and the assets side is a particularly effective attack-detection architecture. Future work is planned to consider more sophisticated stealthy integrity attacks, and investigate the detection capabilities in other control scenarios, such as power balancing and medium voltage-control.

Acknowledgment

This work is financially supported by the Danish project RemoteGRID which is a ForsKEL program under Energinet.dk with grant agreement no. 2016-1-12399 and by the European Union's Horizon 2020 research and innovation program under grant agreement No 774145 within the project Net2DG. The authors would like to thank all project partners for their feedback and input.

References

- [1] F. Skopik, "Security is not Enough! On Privacy Challenges in Smart Grids," *International Journal on Smart Grid and Clean Energy*, 2012.
- [2] MARSH, "Could Energy Industry Dynamics Be Creating an Impending

- Cyber Storm?” <https://www.marsh.com/content/dam/marsh/Documents/PDF/UK-en/energy-cyber-storm-paper.pdf>, 2018.
- [3] C.-H. Lo and N. Ansari, “Decentralized Controls and Communications for Autonomous Distribution Networks in Smart Grid,” *IEEE Transactions on Smart Grid*, 2013.
- [4] A. Bidram and A. Davoudi, “Hierarchical Structure of Microgrids Control System,” *IEEE Transactions on Smart Grid*, 2012.
- [5] R. Pedersen, M. Findrik, C. Sloth, and H.-P. Schwefel, “Network Condition Based Adaptive Control and its Application to Power Balancing in Electrical Grids,” *Sustainable Energy, Grids and Networks*, 2017.
- [6] M. Kemal, L. Petersen, F. Iov, and R. L. Olsen, “A Real-Time Open Access Platform towards Proof of Concept for Smart Grid Applications,” *Journal of Communication, Navigation, Sensing and Services (CONASENSE)*, 2017.
- [7] P. Aristidou, G. Valverde, and T. Van Cutsem, “Contribution of Distribution Network Control to Voltage Stability: A Case Study,” *IEEE Transactions on Smart Grid*, 2017.
- [8] T. le Fevre Kristensen, R. L. Olsen, J. G. Rasmussen, and H.-P. Schwefel, “Information Access for Event-Driven Smart Grid Controllers,” *Sustainable Energy, Grids and Networks*, 2017.
- [9] M. Ma, A. M. Teixeira, J. Van Den Berg, and P. Palensky, “Voltage Control in Distributed Generation under Measurement Falsification Attacks,” *IFAC-PapersOnLine*, 2017.
- [10] A. M. Giacomoni, S. M. Amin, and B. F. Wollenberg, “A Control and Communications Architecture for a Secure and Reconfigurable Power Distribution System: An Analysis and Case Study,” in *Proc. of the 18th IFAC World Congress, Milano, Italy*, 2011.
- [11] D. Kundur, X. Feng, S. Mashayekh, S. Liu, T. Zourntos, and K. L. Butler-Purry, “Towards Modelling the Impact of Cyber Attacks on a Smart Grid,” *International Journal of Security and Networks*, 2011.
- [12] Y. Isozaki, S. Yoshizawa, Y. Fujimoto, H. Ishii, I. Ono, T. Onoda, and Y. Hayashi, “Detection of Cyber Attacks against Voltage Control in Distribution Power Grids with PVs,” *IEEE Transactions on Smart Grid*, 2016.
- [13] R. Pedersen, C. Sloth, G. B. Andresen, and R. Wisniewski, “DiSC: A Simulation Framework for Distribution System Voltage Control,” in *2015 European Control Conference (ECC)*, July 2015.

- [14] S. McLaughlin, D. Podkuiko, and P. McDaniel, “Energy theft in the advanced metering infrastructure,” in *International Workshop on Critical Information Infrastructures Security*. Springer, 2009.
- [15] I. Rouf, H. Mustafa, M. Xu, W. Xu, R. Miller, and M. Gruteser, “Neighborhood Watch: Security and Privacy Analysis of Automatic Meter Reading Systems,” in *Proceedings of the 2012 ACM conference on Computer and Communications Security*. ACM, 2012.
- [16] P. Srikantha and D. Kundur, “Denial of Service Attacks and Mitigation for Stability in Cyber-Enabled Power Grid,” in *Innovative Smart Grid Technologies Conference (ISGT), Power & Energy Society*. IEEE, 2015.
- [17] A. Teixeira, D. Pérez, H. Sandberg, and K. H. Johansson, “Attack Models and Scenarios for Networked Control Systems,” in *Proceedings of the 1st International Conference on High Confidence Networked Systems*. ACM, 2012.
- [18] W. Aoudi, M. Iturbe, and M. Almgren, “Truth Will Out: Departure-Based Process-Level Detection of Stealthy Attacks on Control Systems,” in *Proceedings of the 2018 ACM SIGSAC Conference on Computer and Communications Security*, ser. CCS ’18. New York, NY, USA: ACM, 2018. [Online]. Available: <http://doi.acm.org/10.1145/3243734.3243781>
- [19] R. Pedersen, C. Sloth, and R. Wisniewski, “Active Power Management in Power Distribution Grids: Disturbance Modeling and Rejection.” IEEE, 2016.

Paper G

Distributed flexibility management targeting energy cost and total power limitations in electricity distribution grids

Sandford Bessler, Mohammed Seifu Kemal, Nuno Silva, Rasmus Olsen, Florin Iov, Domagoj Drenjanac and Hans-Peter Schwefel

The paper has been published in the
Sustainable Energy, Grids and Networks 14 (2018) 35–46

The layout has been revised.



Contents lists available at ScienceDirect

Sustainable Energy, Grids and Networks

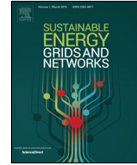
journal homepage: www.elsevier.com/locate/segan

Distributed flexibility management targeting energy cost and total power limitations in electricity distribution grids

Sandford Bessler^{a,1}, Mohammed Seifu Kemal^b, Nuno Silva^{c,d}, Rasmus Olsen^b, Florin Iov^b, Domagoj Drenjanac^{d,1}, Hans-Peter Schwefel^{b,d,*,1}^a TU Wien, 1040 Wien, Austria^b Aalborg University, 9220 Aalborg, Denmark^c EFACEC, Maia, Portugal^d GridData, 83454 Anger, Germany

ARTICLE INFO

Article history:

Received 31 March 2017

Received in revised form 16 February 2018

Accepted 3 March 2018

Available online 13 March 2018

Keywords:

Demand Management algorithms

Distribution grid management

Communication protocols

Distributed system

Testbed evaluation

ABSTRACT

Demand Management uses the interaction and information exchange between multiple control functions in order to achieve goals that can vary in different application contexts. Since there are several stakeholders involved, these may have diverse objectives and even use different architectures to actively manage power demand. This paper utilizes an existing distributed demand management architecture in order to provide the following contributions: (1) It develops and evaluates a set of algorithms that combine the optimization of energy costs in scenarios of variable day-ahead prices with the goal to improve distribution grid operation reliability, here implemented by a total Power limit. (2) It evaluates the proposed scheme as a distributed system where flexibility information is exchanged with the existing industry standard OpenADR. A Hardware-in-the-Loop testbed realization demonstrates the convergence and effectiveness of the approach and quantitatively shows a power quality improvement in the distribution grid.

© 2018 Elsevier Ltd. All rights reserved.

1. Introduction

Distributed generation and new loads in the low voltage (LV) grid, such as electric vehicles, strongly change the consumption patterns of LV grids and may cause needs for reinforcement of grid infrastructure. Alternatively, the investment could be deferred provided that the flexibility in the LV grid can be exploited. However, many Demand Management approaches [1,2] are driven by economic interests and market aspects; but market considerations cannot be applied to small geographical areas, which would be required to address local grid overload. Some countries therefore allow a second level of flexibility control [3], which however can only be applied in certain grid-critical situations.

Demand Management, also called Demand Side Management or Demand Response, has emerged already in the 1970s, but experienced a renaissance with the development of distributed generation, distributed energy resources, and flexibility reporting and usage [4–7]. When market clearance prices are considered in simple Demand Management schemes, in which the local controllers are only price takers, but do not participate on the marketplace, load

peaks may be artificially created when prices are low [5]. Therefore, either more complex, real time price response schemes are needed, or the created peaks may need to be shaved subsequently.

This paper takes a different approach by combining the two targets, energy cost minimization and peak shaving, explicitly in the objective function of the Demand Management optimization algorithms. As the behavior of the overall Demand Management system is determined by several entities in a control hierarchy and is influenced by the interaction protocols deployed between them, the **analysis of the overall integrated system behavior** is complex and needs to be carefully designed and executed. In the evaluation of the proposed algorithms, this paper put its emphasis on the fact that the resulting Demand Management system is a distributed system, in which information and setpoints are exchanged between remote entities via communication networks and protocols. Furthermore, part of the data is transported and aggregated via DSO systems, so different information paths need to be considered. The paper considers a realization of the Demand Management algorithms on top of an open industry standard OpenADR [8]. The two important parts of the objective function of the proposed Demand Management algorithms, the resulting effective customer energy prices and the impact on the distribution grid, are evaluated as part of the paper in a hybrid simulation setup and

* Corresponding author at: GridData, Prälats-Kolbeck-Weg 11a, 83454 Anger, Germany.

E-mail address: schwefel@griddata.eu (H. Schwefel).

¹ Formerly Research Center for Telecommunications (FTW), Vienna, Austria.

in a distributed implementation using a real-time Hardware-in-the-Loop co-simulation approach for the distribution grid and the communication networks.

The rest of the paper is structured as follows: Section 2 positions the paper with respect to the state of the art. Section 3 summarizes the existing architecture that is adopted for the proposed Demand Management system. Section 4 presents the new demand optimization algorithms implemented in controllers at the customer and at the central site, which jointly address energy costs and power limitations. Section 5 describes the implementation of such Demand Management solution using available industry standards for communication between the controllers. Section 6 reports and discusses evaluation results based on a non real-time simulation for different Demand Management scenarios in order to verify the convergence of the proposed algorithms. Section 7 presents an implementation of the Demand Management algorithms and the related communication protocols on a real-time Hardware-in-the-Loop system and shows the resulting benefits for the distribution grid operation. Section 8 concludes and presents further research directions.

2. Relation to state of the art

2.1. Demand management architectures and approaches

Demand Management (DM) schemes are able to shift the consumption in time and are normally classified in incentive-based (direct load control), price-based indirect control or a combination of both [5]. A number of distributed system architectures have been developed to support the DM functionality. The Mas2tering project [9] has developed a system architecture for reporting and tracking energy flexibility at the LV grid level. At the core of the Mas2tering platform is a network of multiple intelligent agents (MAS) that can be associated to a DSO, prosumer or aggregator component, leading to flexible but complex interactions. The project flexiciency [10] developed a system architecture for information exchange between DSO, service providers such as retailer, aggregator and a market place in order to facilitate energy efficiency using metering data, flexibility participation, demand response and local energy control. There is a vast literature on control of energy flows in LV grids, depending on the control time scale. According to the classification in the survey [11], we selected a distributed architecture for a secondary control (energy management) approach, meaning that the customer side provides the first local control level on its DERs, whereas the aggregator provides the top control level.

The architecture adopted in this paper is from [12] and is summarized in Section 3. Similarly to the MAS approach, the adopted architecture uses agents placed at different nodes; in the case of this paper these are specialized agents defined in the standard **OpenADR 2.0b**.

Price-based DM schemes are characterized by dynamicity of price releases: for example, day ahead prices are issued for the whole next day, whereas real-time prices have a much shorter price announcement horizon, e.g. every hour. Real-time pricing systems are complex because a full feedback loop has to be built between the demand and the generation market, so that prices react on the demand changes and vice versa [4,5]. Modeling the market and price building goes beyond the scope of the paper, therefore we assume that the households are price takers and use day-ahead prices.

As the DM functionality is heavily dependent on the underlying communication network, privacy and security threats related to the deployment of the OADR 2.0 technology are relevant, see [8]. Thus, in order to secure the exchange of messages between Virtual Terminal Node (VTN) and Virtual End Node (VEN), OpenADR uses X509v3 certificates and the TLS1.2 protocol with SHA256 ECC or RSA cipher suites, see Chapter 10 in [13].

2.2. Optimization algorithms for demand management

If demand and energy price forecasts are available, the energy management problem can be formulated as resource scheduling problem, using mixed integer optimization techniques. At the customer the consumption has to follow the imposed power setpoints as discussed in [14,15].

Flexibility concepts have been used in the context of electric vehicle charging and flexible home consumption [12,16]. In [15], the authors use the energy stored in the EV fleet and the bounds of this energy to optimize the charging schedules at the fleet level. In [17], the authors present FlexLast, a solution for controlling the power consumption for cooling in supermarkets, based on the flexibility reporting. Energy prices together with flexibility information have been used in a scheduling model in [18].

In this paper, the objective in the design of the DM scheme is on one side to minimize the energy costs (price-based DM), and on the other side to limit the aggregated load (as typically done by direct load control). As shown in Section 4.3, the latter goal will here be achieved at the aggregator by using the power flexibility information from each CEMS together with the total load of the remaining distribution grid customers for the setpoint computation.

2.3. Demand management as distributed system

Since Demand Management works with a large number of geographically highly distributed grid assets, and many of the latter are placed at buildings or industrial plants that are already having an active communication access, the use of Internet connectivity or other already deployed communication infrastructures is necessary to keep the cost of deployment low. On the other hand, such communication networks may show variable delays and also communication outages, either short term leading to packet loss, or even longer communication outages causing dropped connections and lack of real-time information for several minutes to hours [19–22]. Therefore, DM solutions should be made robust such that they can operate under variable communication scenarios.

Due to the complexity and multidisciplinary nature of running demand management over imperfect communications network without endangering customers or businesses, not much assessment of non-ideal communication impact exists. However, many papers point out the criticality of such assessment, e.g. [23], where scheduling of consumption is assessed, while the network performance is only addressed qualitatively. Ref. [24] mentions a larger Danish project, EcoGRID [25], which ran demand management tests on the island Bornholm for long duration, however, relied on a stable communication infrastructure commonly found in Denmark. For EcoGRID, OpenADR and IEC 61850 were used. Reference [26] reviews different aspects of Demand Management and ICT, however, stays with a qualitative comparison. Reference [27] discusses the use of communication in electrical charging situations, positions functionality among actors and discusses also options for communications and their pros and cons, but does not do any quantitative assessment of how communication impacts demand management operation.

This paper presents a demand management approach, which utilizes planning over time horizons of several hours and subsequent adjustments of earlier made plans using a rolling time window of updates which are then sent to controllers. That way the approach **achieves to be robust to communication disruptions** of durations up to a few hours in certain reference test scenarios.

2.4. Existing evaluation approaches and their application to demand management

Most of the existing work on Demand Management uses either simulations for evaluation [28,29] or uses numerical

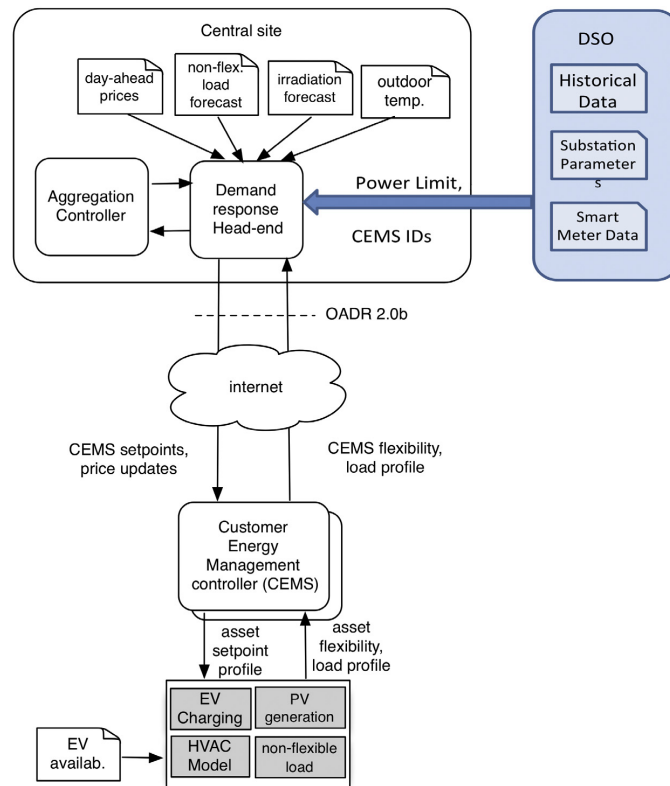

Fig. 1. Demand Management architecture and information flows.

analysis [30,31] to study price based programs or peak load reduction. Recent work also points out that Demand Management systems impact the distributions grid [32], while they use simulation as analysis method. Other papers used a combination of simulation methods and a testbed with real households [33]. This paper contributes the novel aspect of the evaluation of the Demand Management system as a distributed system with data exchanges over actual communication protocols and measurement values obtained from real-time grid simulation.

3. Demand management architecture

We first summarize the used architecture which is adopted from [12] and visualized in Fig. 1: an aggregation controller interacts with a number of customer energy management controllers (CEMS). The CEMS controller attempts to follow the setpoints sent from the aggregation controller by controlling the local flexible loads. In this way the aggregator has no direct control on a specific customer asset such as EV or PV generation.

For the communication between the aggregation controller and the CEMS controllers we selected the standardized OADR 2.0b protocol, which runs over an Internet stack (http/TCP/IP). The CEMS controllers optimize their consumption plan based on day ahead prices, local flexibility information and local generation and report this plan to the aggregation controller, together with flexibility information. The aggregation controller receives reports from all CEMS and calculates planned setpoints for each CEMS based on the total demand. The effect is an optimized schedule over the

time horizon. These control cycles, both on the CEMS controller and aggregation controller, are executed in periodic intervals, subsequently chosen as 15 min inspired by other distribution grid applications [19,34,35].

The central site (top of Fig. 1), also called Demand Management Center (DMC), can be operated by a third party, like an aggregator. In this paper, we introduce an additional interface from the central site to the DSOs, shown in the upper part of Fig. 1. On this interface, the DSO can announce upper bounds on the total power that a set of CEMS nodes that are connected to the Demand Management system should not exceed. The DSO can determine and also dynamically modify the upper bound based on daily consumption profiles, or based on current LV grid status, as e.g. observed via measurements at customer smart meters, and therefore, customize peak shaving/limiting on secondary substations or MV feeder sections. These upper bounds are subsequently used in the aggregation controller as described in Section 4. As the bound only refers to the sum of power of all connection points that are controlled by CEMS nodes connected to this DMC, the DSO has to be aware of the CEMS–DMC relation. On the other hand, the aggregation controller does not need to be aware of the LV grid topology, since the DSO communicates what subset of CEMS nodes the upper bound should be applied to.

While there can be multiple Demand Management Operators that manage different sets of customer premises within a distribution grid, the analysis in the subsequent sections focuses on a smaller part of the distribution grid and assumes that the locally relevant assets are managed by one DMC.

Table 1
Notation summary.

y_j	Charging power in kW during period j
z_j	HVAC heating control signal (binary)
gf_j	Generation factor in period j
E_j^{EV}	EV charged energy until period j
E_j^{HVAC}	Energy consumed until period j
p_j^{in}	Household net power from or to the grid
p_j^{in+}	$p_j^{in+} = p_j^{in} > 0$, zero else
p_j^{load}	Non-flexible load
E^{pasv}	Heat from persons, appliances, sun, ventilation
E^{trans}	Lost heat through the walls
$\underline{P}_i, \bar{E}_i, \bar{P}_i, \bar{E}_i$	Power, energy flexibility of CEMS i

4. Demand management algorithms

The Demand Management system uses two optimization algorithms, that jointly address the price-based optimization and the load limitation in a distributed manner: (1) the customer energy management algorithm running at customer premises; (2) the algorithm in the aggregation controller at the central site. Each algorithm solves a particular optimization problem. For both optimization models we apply a commonly used scheme for forward planning known as model predictive control (MPC) [36] that creates a plan for the defined time horizon, however the control action is applied only for the next period. This method requires however that predicted values for the demand and for the energy prices are available.

4.1. Overall procedures

In Fig. 2, we depict the data flow in the processing at the DMC and CEMS controllers. It should be emphasized that each CEMS balances the energy over the time horizon, whereas the aggregation controller in the demand management controller (DMC) balances the energy between all the participants. In the figure p^{in} denotes the preferred load, $flexMin$, $flexMax$ is the flexibility information.

As previously mentioned, the basic idea of reporting flexibility is to transfer the control of the house energy management to the aggregation controller that participates in the energy market. At the same time, asset flexibility is used to achieve local optimization goals. This leads to a multi-objective optimization problem, in which the terms can be weighted differently in order to investigate the solution properties.

4.2. CEMS algorithm

The CEMS algorithm aims to fulfill three goals: (1) follow the setpoint imposed by the DMC, (2) maximize the customer's local generation by photovoltaics, (3) minimize the energy costs determined by the previously received day-ahead prices. When formulating the algorithm with respect to the consumers and generators shown in the bottom of Fig. 1 (PV, EV, HVAC), the results of the CEMS optimization are:

- a plan of the preferred net power consumption or power injection in the grid p_j^{in} , $j \in N$.
- a plan for the control actions: (a) z towards the HVAC, (b) y towards the EV charging point, (c) gf , towards the PV inverter.

The resulting optimization problem is shown in Eqs. (1)–(9), using the notation in Table 1.

The first term in Eq. (1) makes the CEMS follow the setpoints imposed by the DMC, and does so by minimizing the deviation between the CEMS net consumption (or injection in the grid) and the CEMS setpoint reference P^{ref} , similarly to the objective used in [16]. The second term maximizes the self-generated power $gf P^{gen}$ over the prediction time horizon. PV Generation may be curtailed to accommodate the setpoint, but with this term, self-consumption will be maximized. Finally, the third term uses the day ahead prices to minimize energy cost. The market clearing price c_j is published and available the day before, for the whole grid. As the prices are positive, the minimization will normally cause the reduction of total energy consumption. However, less energy consumption is not always desired, especially when variable generation resources and storage are involved. For instance, in the EV case, minimum consumption would cause that the charging will stop once the minimum demand d_{min} is reached. In order to obtain a balanced energy consumption, we set c_j relative to an average value. In this way positive values will discourage consumption, and negative values will increase consumption.

The optimization program in Eqs. (1)–(9) is quadratic and has integer (binary) variables. The constraint (2) expresses the power flows balance at the house grid connecting point. The constraints (5) and (6) express the accumulation of energy in the battery, such that it has to be within the flexibility limits. Similarly, the HVAC system is constrained in (7) and (8).

CEMS Optimization problem:

Minimize

$$K_1 \sum_{j \in N} (p_j^{in} - P_j^{ref})^2 - K_2 \sum_{j \in N} gf_j P_j^{gen} + K_3 c_j p_j^{in+} \quad (1)$$

The coefficients K_1 , K_2 and K_3 are weighting factors for the three different targets introduced at the beginning of the subsection. Furthermore, these coefficients remove the different units from all three terms. The optimization is done subject to the following constraints:

$$p_j^{in} + gf_j P_j^{gen} - y_j - p_j^{load} - z_j P^{HVAC} = 0, \quad j \in N \quad (2)$$

$$0 \leq y_j \leq P_{max}^{EV}, \quad j \in N \quad (3)$$

$$z_j \in \{0, 1\}, \quad j \in N \quad (4)$$

$$E_j^{EV} = E_{j-1}^{EV} + y_{j-1} T, \quad j \in N - \{0\} \quad (5)$$

$$\underline{E}_j^{EV} \leq E_j^{EV} \leq \bar{E}_j^{EV} \quad (6)$$

$$E_j^{HVAC} = E_{j-1}^{HVAC} - E_{j-1}^{trans} + E^{pasv} + z_{j-1} P^{HVAC} T, \quad j \in N - \{0\} \quad (7)$$

$$\underline{E}_j^{HVAC} \leq E_j^{HVAC} \leq \bar{E}_j^{HVAC}, \quad j \in N \quad (8)$$

$$gf_{min} \leq gf_j \leq 1, \quad j \in N \quad (9)$$

4.3. DMC algorithm (aggregation controller)

The main role of the aggregation controller is to determine power setpoints P_i^{ref} for each CEMS in a way that: (1) the setpoint is close to the preferred load plan P_i^{in} of the CEMS controller i , (2) the setpoint is feasible with respect to the flexibility of the generators and loads aggregated by the CEMS controller, and (3) the sum of the setpoints for the set of assets in the same LV grid does not exceed the upper bound previously obtained from the DSO (see upper part of Fig. 1). A setpoint for the node i is related to its power consumption prediction by the relation $P_i^{ref} = P_i^{in} + \beta_i$, where the latter is the requested adaptation compared to the prediction. \underline{P}_i^{CEMS} , \bar{P}_i^{CEMS} is the overall power flexibility, obtained by aggregating the flexibilities of individual CEMS assets. The optimization problem is defined as follows:

$$\min \alpha \sum_{i \in B} \beta_i^2 + (1 - \alpha) \sum_{j \in N} (P_j^{ref} - P_j^{ref-})^2 \quad (10)$$

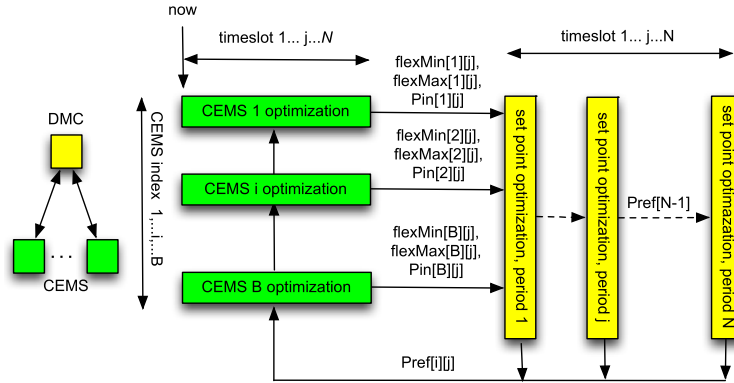

Fig. 2. Data flow and processing in the aggregation controller (DMC) and CEMS controllers.

The coefficient $\alpha \in [0, 1]$ defines the relative weight of the first part of the objective function. Optimization will be subject to the following constraints:

$$P_{\min}^{LV} \leq \sum_{i \in B} (P_i^{\text{in}} + \beta_i) \leq P_{\max}^{LV} \quad (11)$$

$$P_i \leq P_i^{\text{in}} + \beta_i \leq \bar{P}_i, \quad i \in B \quad (12)$$

The objectives of the optimization problem (10) are to minimize the total squared error between offered loads of the households and the estimated setpoint values, and to minimize the difference between the setpoint at time t and the setpoint at time $t - 1$, similarly to [15,12]; therefore we denote $P_i^{\text{ref}} = P_i^{\text{in}} + \beta_i|_{t-1}$. The constraint (11) limits the total consumption load respectively the power insertion into the grid. The constraints (12) make sure that the power flexibility constraints are met.

5. Demand management system realization

Main target for the realization of the DM system was to create a practical implementation that can subsequently be assessed. Any subsequent design choice was therefore taken with priority on the use of existing (industrial) standards. Such choices allow a higher degree of interoperability as opposed to proprietary solutions and protocols.

The DM implementation used an existing generic tool [37] to optimize the quadratic problem (10)–(12). Java REST services were used for communication between CEMSs and DMC. These REST services are based on the HTTP Request/Response paradigm. The CEMS implements both, HTTP server and REST client for the communication with the DMC platform, while the DMC only implements the REST client. Both components, CEMS and DMC, are implemented as time-triggered state machines where states are responsible for data collection, data processing, actuation if necessary, and data dissemination. The information exchange between CEMS controllers and aggregation controller is implemented on top of the OpenADR protocol [8]. Accordingly, each CEMS is a Virtual End Node (VEN) that communicates with the Head-end, which implements the Virtual Terminal Node (VTN). The OpenADR 2.0 protocol can work with two kinds of communication mechanisms: push and pull. In the push mechanism, the operations can be initiated either by the VEN or VTN. In the pull mechanism, only the VEN can initiate operations. In this paper, only the push mechanism is used, meaning that both the headend and CEMS can be servers of information. The background load of the households is forecasted at the DMC using historic data. The maximum power

of the PV is estimated based on an irradiation forecast. These two forecasts together with the market prices for the day, are sent by the headend to the CEMS. Each CEMS controller sends requests every 15 min to the DMC and attaches flexibility reports, which are used to by the DMC to update the setpoint values for the CEMS.

The DMC uses two power limits: a negative value as bound on total generation by the LV grid and a positive value as upper bound on total consumption. While the scenario in Fig. 1 assumes these to be provided dynamically by the DSO, for the evaluations later, the setting is simplified to make these statically configured parameters. The weighting factors in Eq. (1) are set to $K_1 = 20$, $K_2 = 1$, $K_3 = 0.1$, and the weighting factor in Eq. (10) is set to $\alpha = 0.99$.

In order to assess the control functionality, a benchmark grid based on a real MV/LV grid operated by Himmerland Elforsyning near Aalborg in North Jutland, Denmark, was modeled. We use a scaled down version of this grid, with 38 households, shown in Fig. 3. All 38 households are participating in the Demand Management scheme and thus have a CEMS node deployed.

5.1. Asset models

Within a customer site we assume the presence of four types of assets, shown in the bottom of Fig. 1. The appliances deliver flexibility information to the CEMS controller, and the CEMS controller calculates a control signal, specific for each appliance type as described in the previous section. The following describes the models and assumptions that are used in the system realizations, both in the simulations and experimental testbed.

PV: Concerning generation, we use a PV model that obtains the generated power from a solar irradiance model as follows:

$$P^{\text{gen}} = \min(P_{\text{rated}}, \eta A I_{\text{solar}})$$

where η is the efficiency of the solar cells and A is their area in m^2 , and P_{rated} is the maximum power of the inverter. Assumption is that the CEMS controller can derate the generated active power. To control a certain range of this power output, we introduce the generation factor $gf \in [gf_{\min}, 1]$ with $gf_{\min} < 1$. For a certain available power P^{gen} , the PV generates therefore the power $p = gf P^{\text{gen}}$ with $p = gf P^{\text{gen}} \leq p \leq P^{\text{gen}} \leq P_{\text{rated}}$.

EV: An EV charging point is a variable load that is available in an estimated interval between EV arrival and departure $[t_a, t_d]$. We can specify the minimum required charging energy d_{\min} (i.e. for the next 50 km) and d_{\max} (corresponding to a full charged battery). Like in most of previous research works [15,38], we assume the

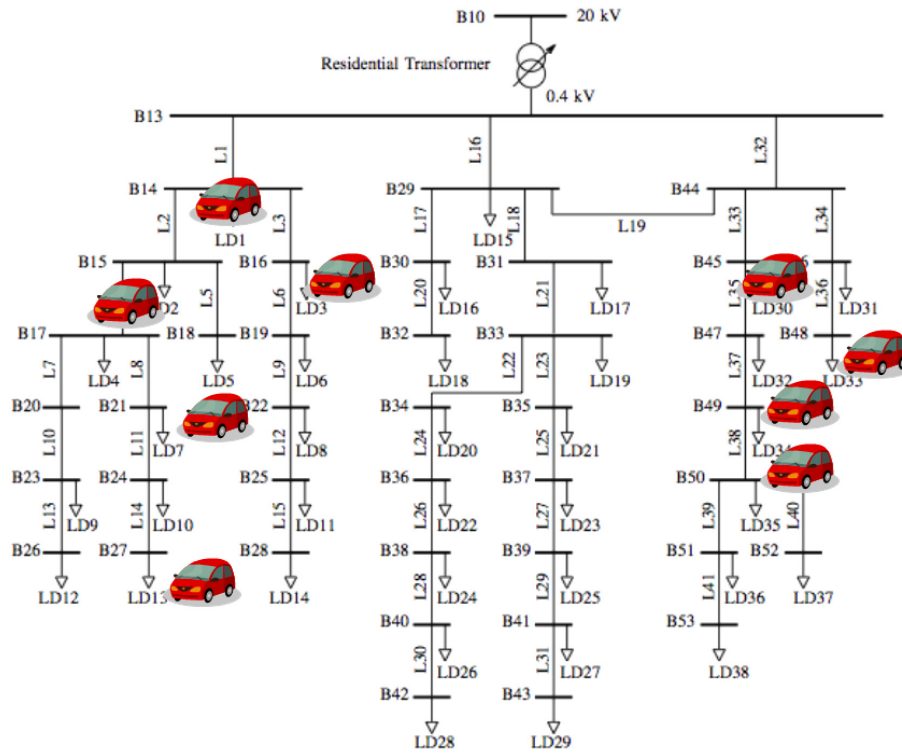

Fig. 3. LV grid used for the evaluations.

Table 2
List of expected savings under different conditions.

Scenario	Constant price	Day-ahead price	Day-ahead price excessive demand
Total energy/day	765 kWh	1011 kWh	1118 kWh
Total cost	33,75 €	39,70 €	48,25 €
Resulting avg. price	44,23 €/MWh	39,28 €/MWh	43,15 €/MWh
Savings (si)	0	11%	2,5%

charging power can be varied continuously up to a maximum value P_{max} . Energy losses are neglected. The solution of the charging problem, if feasible, amounts to finding the charging power in each time period. The flexibility of EV charging is given by the energy boundaries E_j^{EV} , \bar{E}_j^{EV} that define the minimum respectively the maximum charged energy at any time during the planning horizon, independently of the control strategy (see [12] for details).

HVAC: A typical flexible load in a household, HVAC (heating, ventilation and air conditioning) has been selected for heating (or cooling) the house. A simple thermodynamic model is used, based on heat storage, which is influenced by walls, window isolation, persons in the room, appliances and air movement in the room [39]. The model also accounts for irradiation and ventilation losses with respect to outside temperature. Models also include the size of house (both area and volume). A thermostat controls the temperature. The HVAC flexibility (see [12] for details) reflects the following behavior of the heating system: the maximum energy flexibility curve becomes flat when the maximum allowed indoor temperature is reached. However, the room cools down via the

walls and windows, so it eventually starts heating again when the minimum indoor temperature is reached.

For the evaluations, all the households have been equipped with 5 kW HVACs for heating and PV panels with a power $P_{rated} = 4$ kW. Eight houses have been configured with EV charging points associated to various parking periods and $P_{max}^{EV} = 6$ kW. The HVACs' initial indoor temperature was uniformly distributed between 19.1 and 20.9°C; the outside temperature was 1°C (January).

6. Hybrid simulation evaluation

The first objective is to verify the convergence and show the benefits of the algorithms in various load situations.

In order to achieve this aim, we use a hybrid simulation model, in which the controller processes and the web-service-based OADR protocol are implemented and deployed on target controller hardware. The consumption is simulated, the variable loads being represented by deterministic models, whereas the non-controllable loads are obtained from perfectly predicted profiles (historical data).

The evaluation experiments have been performed for 24 h of simulated time with a 6 h planning horizon.

6.1. Evaluation metrics

In order to quantitatively compare different simulation runs, we define as load overload index (O_{ix}) the relative occurrence of total power exceeding nominal transformer power P_{max}^{LV} :

$$o_{ix} = \frac{1}{n} \sum_{j=1}^n (P_i - P_{max}^{LV}) / P_{max}^{LV} | P_i > P_{max}^{LV} \quad (13)$$

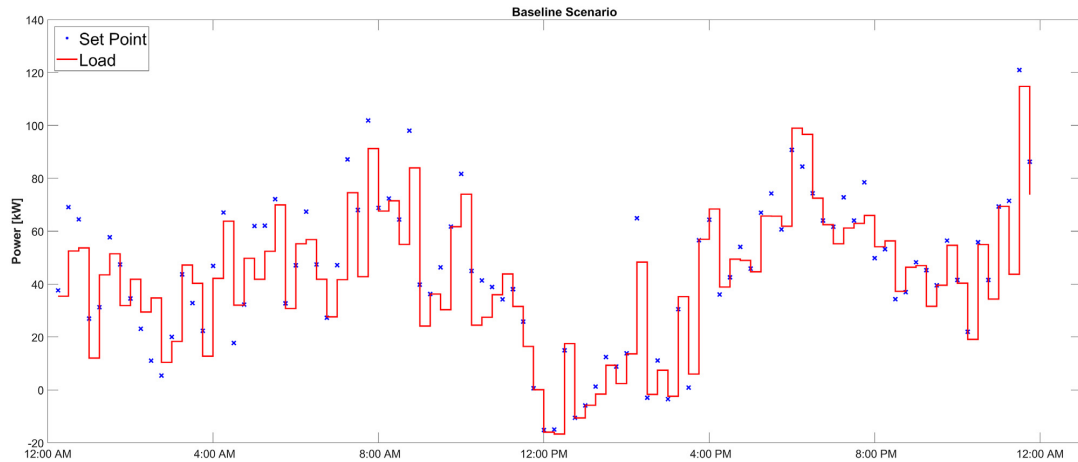

Fig. 4. Total load and total setpoint of 38 households in the reference LV grid. (For interpretation of the references to color in this figure legend, the reader is referred to the web version of this article.)

The index j identifies all simulated time intervals, each of duration 15 min of simulated time.

Analog, for the excessive generation we obtain

$$o'_{ix} = 1/n \sum_{j=1}^n (P_j - P_{\min}^{LV}) / P_{\min}^{LV} | P_j < P_{\min}^{LV} \quad (13')$$

Further, we consider the daily energy costs using day-ahead prices. We define the saving index as the relative difference between the costs in a fixed-price and day-ahead price scenario.

$$s_{ix} = 1 - \sum_{j=1}^n (c_j P_j^{in}) / c P_i^{in} \quad (14)$$

6.2. Baseline case and excessive demand/generation

The first set of simulations considers a Demand Management scenario in which communication between CEMS and DMC is ideal, i.e. no losses and no delay; the communication is in fact local between processes on one machine using the local loopback interface, so only the TCP socket processing time and the protocol layers on top are influencing the information exchange.

In a **baseline-scenario** setting, day ahead prices and flexible loads are used by the CEMS to reduce energy costs. Fig. 4 shows the total load from 38 CEMS households (red line) and the resulting cumulated setpoints (blue) sent to them by the DMC. The impact of price information is shown in Table 2: as reference we compute the energy costs for the baseline scenario with constant energy price. Using day-ahead prices leads to a cost saving of about 11%, with the downside that it creates artificially high loads in low-price time periods.

The direct load control functionality can be classified in excessive total demand that has to be curtailed (peak shaving, load curtailment, valley filling, etc.) and excessive generation in which the total feed-in power has to be limited.

In order to simulate a case of **excessive demand**, Fig. 5 assumes a Power limit that is communicated by the DSO as $P_{\max}^{LP} = 70$ kW for the 38 households in this LV grid; this value represents in practice the maximum capacity of the secondary substation's transformer. Fig. 5 shows that the setpoints are now staying below this boundary, and by inspection of the detailed data, it is possible to see that these lower setpoints do in fact reduce the demand

Table 3
List of overload index for different cases.

Scenario	Baseline no limitation	Excessive demand	Excessive generation
Overload index (oi)	2,6%	1,36%	0%

from the set of households in the peak periods; however, as the CEMS target a combination of different objectives, there remain situations (e.g. around 4pm in Fig. 5), in which the total load exceeds the limit.

Table 3 shows the corresponding improvement of the overload index: the use of the total power limit from the DSO reduces the overload index to almost half in the excessive demand scenario. A consequence of the stronger limitations by the lower total power bound is that the price savings are reduced to about 2.5%, see last column of Table 2.

Finally, in case of excessive generation, the DSO is here assumed to limit the amount of power that shall be injected from the LV grid to the MV grid to below 100 kW. The constraint is pushed via the setpoints to the CEMS level, where it activates the local (active power) PV control. Details of this simulation run are omitted here; the last column of Table 3 calculated according to (13) shows that the approach prevents in the considered excessive generation scenario the exceedance of this generation power limit at the substation.

6.3. Demand management robustness to communication disruptions

Even though the communication in the hybrid simulation setup is between local processes on the same node, the impact of communication disruptions can be investigated by disabling the inter-process communication in certain time periods. The goal of these experiments is to analyze the behavior of the DM system when communication disruptions affect the interaction between DMC and CEMS. In Fig. 6, the communication between the DMC and all CEMS is interrupted as shown in the period starting around 4pm simulated time by the green line in the figure. As the algorithms introduced in Section 4 always work with a time-horizon in the future (6 h in our case) the previous setpoints for the full time horizon are still cached locally. In this way, the total load is kept within the limits known before the communication failure. The DM scheme is therefore quite robust to disconnections, provided the power limit does not change drastically.

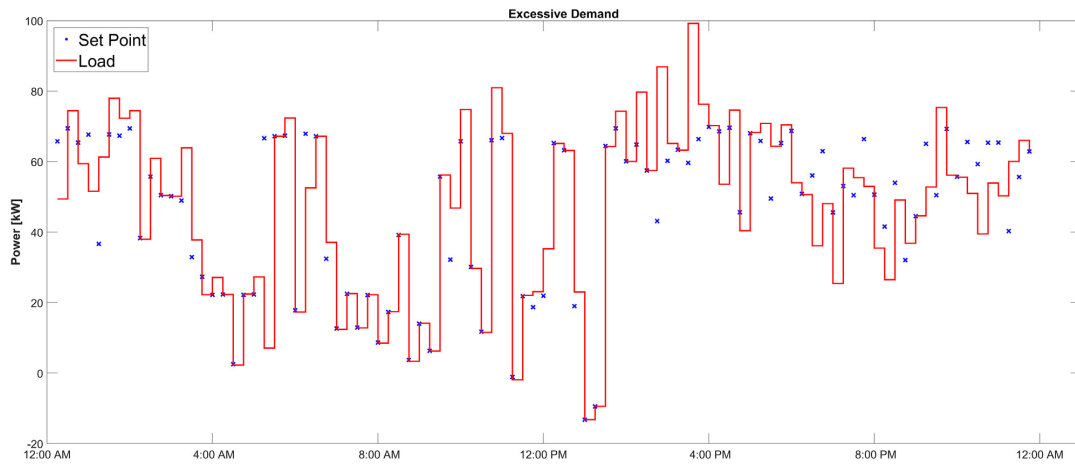

Fig. 5. Excessive demand scenario, the power limits applied by the DM solutions provide setpoints that reduce the overload.

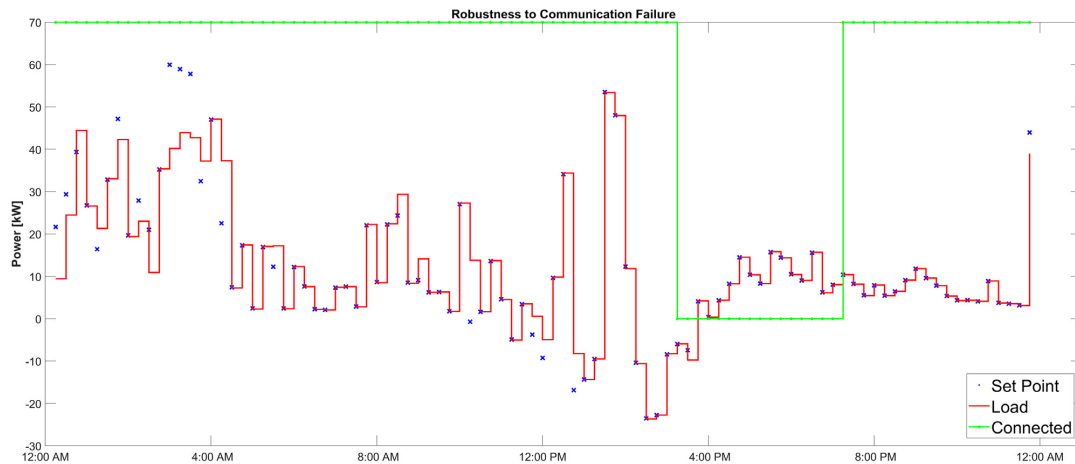

Fig. 6. Total load and set points during communication failure (marked by the drop of the green line); the setpoints in that period are the ones obtained and communicated as plan by the DMC controller before the communication interruption. (For interpretation of the references to color in this figure legend, the reader is referred to the web version of this article.)

6.4. Input data variability

The demand management solution in this paper uses the day ahead prices, see e.g. [40], which are determined during the day before; therefore, they are known exactly at the time of the optimization. Only when applying other market and pricing models, such as the ones from intra-day markets, the optimization algorithm may need to be extended to take into account uncertainties of the price prediction: The current optimization algorithm will periodically, using a rolling window, update the setpoint plans based on the latest known price information; when the accurate pricing information is only available on shorter time horizons, the impact of communication outages as analyzed in the previous subsection may increase. A quantitative study of such modified pricing scenarios is however beyond the scope of this paper.

The other important inputs to the optimization algorithm are the loads, which are subject to uncertainties. For the evaluation in this section, we used a general household profile for background load (e.g. lighting, cooking, entertainment, etc.) and add to it the

flexible loads (EV charging, heating, cooling, etc.) obtained from the asset models, see Eqs. (5), (7). As this information is locally available at the CEMS, communication outages between CEMS and DMC would not affect its quality; however, a deviation of the loads from the prediction at the CEMS node may not reach the DMC in time, depending on the duration of the communication outages, which may delay or prevent a corresponding update of the plan. As the prediction methods are not in focus of this paper, a detailed analysis of this aspect is left for future work.

7. Real-time verification

The simulation experiment in the previous section showed the convergence and the benefits of the presented demand management algorithm. In order to verify that this behavior can also be achieved in a distributed setting with actual communication between different entities, this section introduces a real-time testbed. Secondly, the testbed will be used in order to investigate the impact of the demand management scheme on power quality,

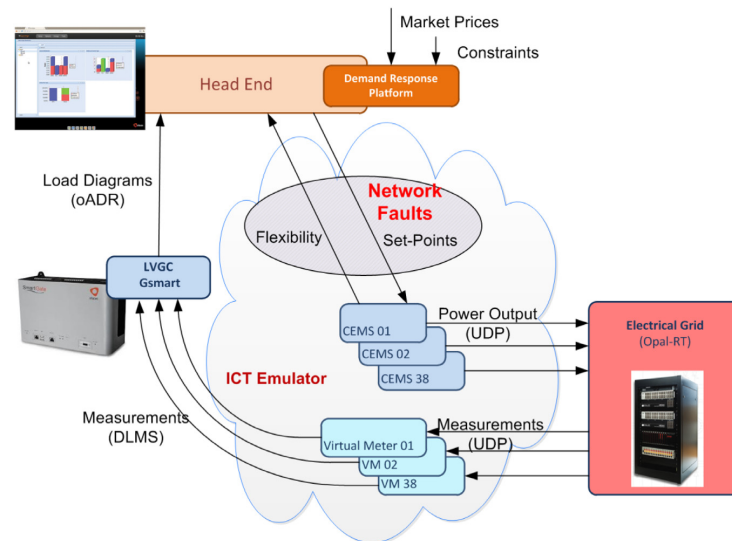

Fig. 7. Hardware-in-the-loop testbed set up for demand management with real-time grid simulation in the lower right.

specifically here on voltage variations in the buses of the LV grid. In order to achieve these goals, we introduce a hardware-in-the-loop testbed [41], which contains a fine-granular accurate real-time grid model and therefore provides information on the voltages and currents in the grid.

7.1. Testbed implementation

A hardware-in-the-Loop (HIL) testbed with real-time grid simulation is used to study realistic demand management scenarios with detailed grid models. The testbed is shown in Fig. 7; in contrast to the hybrid simulation, it integrates an OPAL-RT grid simulation, executes the actual communication between distributed entities via a communication network emulator, and it contains an industrial grid controller [42], which is used by the DSO to access the Smart Meter data at the customer sites.

Opal-RT is a real-time grid simulation that provides complex grid component models. OPAL-RT is the state of the art simulation platform widely used for design and validation of control and protection systems. It gives an added benefit of capturing the transmission, distribution and generation units with smaller time scales and fine granularity [41].

The industrial smart grid controller accesses the Smart Meter readings in DLMS (Device Language Message Specification) format. In order to compute, it subtracts from the total load the loads of all customers that are not part of the demand management scheme. The result is sent to the head-end via OADR. All CEMS controllers and their local asset models (again re-using the ones from the hybrid simulation) run on one dedicated server. The aggregation controller and the Head-end, run on a separate machine representing the Demand Management Center (DMC). Communication network delays, IP packet losses and communication disruptions can be emulated on communication between CEMS and Head-End as well as between other distributed nodes (e.g. Smart Grid Controller and Smart Meters, Smart Grid Controller and DMC). The communication network emulator works on top of a Gigabit Ethernet network [41]. The HIL property is used as a tool to demonstrate that the concepts work also in a real-time distributed setup and that the components are able to send and receive data

via the full protocol stack realization in different subsystems in the architecture.

The simulated household loads are sent via UDP sockets to the OPAL RT grid emulation. The resulting voltages and currents (and hence power values) are obtained from the real-time grid simulator via UDP sockets by virtual Smart Meters, that are shown in Fig. 8. The virtualization of a smart meter was done to assure complete transparency in mimicking a real customer, using the same structure and protocols as a real smart meter. Each time a (P, Q) value pair is received from the consumer socket, it is forwarded to the gridsim socket (and hence passed to the real-time grid simulator) and the instantaneous meter values are updated using the “Compute Instant Values” function. Taking the elapsed time since the last update, the “Integrate” function updates the energy registers. Periodically the “Store Load Profile” function captures selected registers and appends them to the table provided by the Load Profile Register. The emulation is implemented using C++ and the Gurux DLMS library. Each smart meter emulation process mimics a single virtual smart meter.

7.2. Verification tests

The benchmark grid in Fig. 3 is implemented with the same parameters as in the hybrid simulations, see Section 5. The experiments in this section are performed in real-time, as the simulated CEMS consumption signals are inserted into the OPAL-RT. From there, virtual smart meters recreated metering information to be collected at the central site.

The tests described in Section 6 have been repeated. The results were identical when replaying the scenario of ideal communication. Therefore, the distributed realization using the actual protocol implementation was verified to operate correctly and all data flows between the different entities could be successfully established.

7.3. Evaluation of impact on distribution grid

One main advantage of the HIL testbed, as opposed to the hybrid simulations in the previous section, is the presence of the detailed OPAL-RT based grid emulation. The results in this section focus

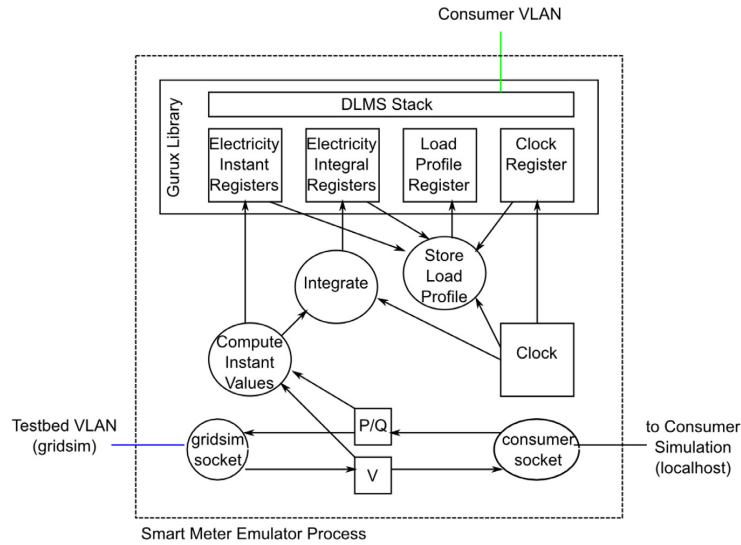

Fig. 8. Virtual smart meter implementation.

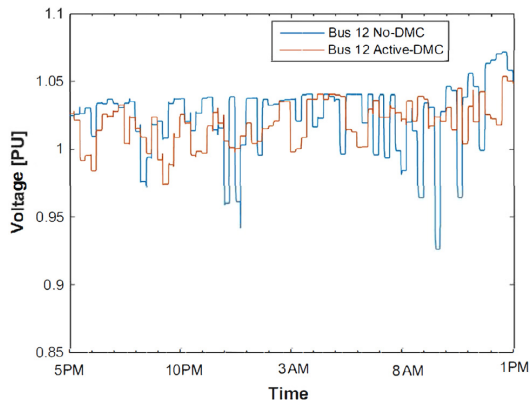

Fig. 9. Voltage trace comparison for secondary side of transformer looking at one of the buses. (For interpretation of the references to color in this figure legend, the reader is referred to the web version of this article.)

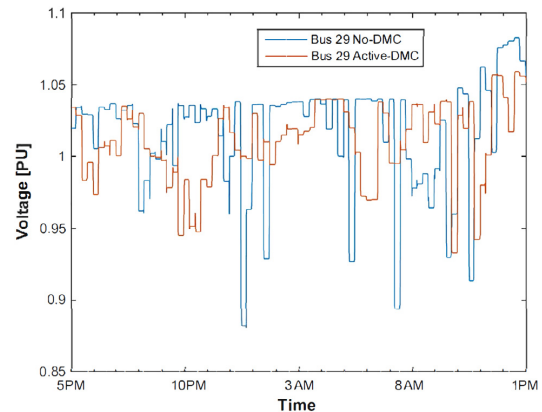

Fig. 10. Voltage trace for bus 29 at feeder line end. (For interpretation of the references to color in this figure legend, the reader is referred to the web version of this article.)

on the impact of the Demand Management on the voltages at the buses. For this purpose, we compare in Figs. 9 and 10 scenarios with No-DMC and Active-DMC utilizing a total power limit from the DSO of 70 kW. Two buses, Bus-12 located at the secondary side of the transformer in Fig. 9, and Bus-29 at the end of the feeder in Fig. 10 are presented for comparison. The plots show 20 h of real-time test performed for both scenarios, with and without setpoints from the DMC.

Note that due to the presence of PV generation in the LV grid, the voltages at the buses may frequently be higher than the nominal voltage. The dips in Figs. 9 and 10 show that due to high consumption, the voltages can drop, sometimes even below 95% of the nominal voltage for Bus 12. The voltages drop even worse, below 90%, at Bus 29 as this bus is at the feeder end.

The red lines in Figs. 9 and 10 show the stochastically same scenario as the blue line, but the DMC is active and uses ideal (Gbit Ethernet) communication to send setpoints to the different CEMS units. The active DM solution significantly mitigates the voltage drops compared to the blue line, where the DMC does not send any setpoints to the CEMS.

Therefore, the power limitation is shown to be a simple but effective approach to achieve grid-friendly behavior, without requiring direct control of assets. Similar results can be achieved for an excessive generation scenario such as shown in Table 3 earlier.

In summary, the results from the real-time testbed confirm the validity regarding protocol and asset behavior from the hybrid simulations, and in addition the detailed real-time grid model

demonstrated the benefits for the distribution system operator regarding voltage quality in the LV grid.

8. Conclusions and outlook

This paper introduced a set of distributed algorithms that are executed in an existing hierarchical Demand Management architecture, in which a Demand Management Center communicates to CEMS nodes at the customer site, which in turn interact with local flexible assets. Novelty of the algorithms is that they jointly address price optimization and total load limitation. The latter uses an upper bound, or lower bound in case of negative values from generation scenarios, on total power of all customers in the LV grid that participate in the DM scheme. This bound is provided by the DSO, which uses Smart Meter readings in order to obtain the load characteristics of LV customers that do not participate in the Demand Management scheme. In order to match realistic practical deployments, the industrial standard OADR has been selected for the communication between CEMS and DMC as well as between Smart Meter data concentrator and DSO.

The convergence of the algorithm and the impact on the energy costs and total LV grid power was subsequently shown in a hybrid simulation model using a realistic LV reference grid. Subsequently, the hierarchical DM architecture has been set up as a distributed system in a Hardware-in-the-Loop testbed interfacing with a detailed real-time grid simulation. The operation of the DM system was validated in this testbed and the resulting positive impact on the voltage quality in the LV grid was shown. Both the hybrid simulation and the testbed use actual realistic communication protocol implementations so that the impact of communication network degradation on the schemes can be investigated. If disconnections between the CEMS and the aggregation controller persist for up to few hours (e.g. due to controller or communication network failure), the load limitation is still kept via a robust algorithm design that caches a future plan of setpoints for the next 6 h in the CEMS. The optimization is performed for multiple and distributed CEMS at the same time for the same time intervals. Inter-dependencies between CEMSs with respect to the power consumption and generation are taken into account when calculating the future setpoints and also for the DSO power limit. Using such approach, the resilience to longer disruptions of the communication network is drastically improved, and in addition the dependence on short term performance of the used communication technologies and protocol stacks is reduced.

Using day-ahead prices provides advantages, while future work should also investigate real-time prices that are adapted dynamically via bidding. Such dynamic markets may then lead to higher variability, in which the communication network performance can then again be an influencing factor [43]. For further robustness enhancements, real-time state estimation for communication networks, QoS-adaptiveness, adaptiveness of control mechanisms to imperfect networks, and mechanisms for ICT fault/attack detection are essential functionalities when utilizing heterogeneous ICT infrastructures in Smart Grid control scenarios [44,45]. Furthermore, the impact of security related protocols [46] needs to be included in the analysis of such systems.

Acknowledgments

This paper contains results from the research project ‘Smart Control of Energy Distribution Grids over Heterogeneous Communication Networks – SmartC2Net’, www.smartc2net.eu, which was supported by the European Commission within the 7th Framework Program under grant number 318023. The authors would like to thank the SmartC2Net partners for their input and discussions, in particular Andre Simões, Filipe Campos, Antonio Carapato from EFACEC for their contributions to the Demand

Management Platform definition, Eduard Hasenleithner formerly Forschungszentrum Telekommunikation Wien (FTW, Research Center for Telecommunications Vienna) for the implementation of the Virtual Smart Meters and part of the control algorithms. Part of the work for this paper was done while several of the authors were affiliated with FTW, see front page.

References

- [1] G. Strbac, Demand side management: Benefits and challenges, *Energy policy* 36 (12) (2008) 4419–4426.
- [2] F. Rahimi, A. Ipakchi, Demand response as a market resource under the smart grid paradigm, *IEEE Trans. Smart Grid* 1 (1) (2010) 82–88.
- [3] T. Deutsch, F. Kupzog, A. Einfalt, S. Ghaemi, Avoiding grid congestions with traffic light approach and the flexibility operator; CIREC Workshop 2014, Rome, Italy; 11.06.2014 - 12.06.2014; in: Challenges of implementing Active Distribution System Management, CIREC, 2014.
- [4] P. Palensky, D. Dietrich, Demand side management: Demand response, intelligent energy systems, and smart loads, *IEEE Trans. Indust. Inform.* 7 (3) (2011) 381–388.
- [5] M. Alizadeh, X. Li, Z. Wang, A. Scaglione, R. Melton, Demand-side management in the smart grid: Information processing for the power switch, *IEEE Signal Process. Mag.* 29 (5) (2012) 55–67.
- [6] B. Biegel, P. Andersen, J. Stoustrup, L.H. Hansen, D.V. Tackie, Information modeling for direct control of distributed energy resources, in: IEEE American Control Conference, ACC, 2013, pp. 3498–3504.
- [7] Dieter Gantenbein, Carl Binding, Bernhard Jansen, Aditya Mishra, Olle Sundstrom, EcoGrid EU: An efficient ICT approach for a sustainable power system, in: Sustainable Internet and ICT for Sustainability (SustainIT), IEEE, 2012.
- [8] OpenADR Alliance, OpenADR 2.0b Profile Specification v1.0, 2013.
- [9] MAS2TERING Consortium, Deliverable D2.2: Mas2tering Platform design Document, Feb.2015, <http://www.mas2tering.eu/publications/>.
- [10] Flexiciency Consortium, Deliverable D2.2: Definition of overall system architecture, 2016, <http://www.flexiciency-h2020.eu/deliverables-and-scientific-publication/deliverables>.
- [11] D. Olivares, A. Mehrizi-Sani, A. Etemadi, C. Canizares, R. Iravani, M. Kazerani, A. Hajimiragha, O. Gomis-Bellmunt, M. Saadedifard, R. Palma-Behnke, A. Jimenez-Estevéz, N. Hatziargyriou, Trends in microgrid control, *IEEE Trans. Smart Grid* (2014).
- [12] S. Bessler, D. Drenjanac, E. Hasenleithner, N. Silva, Using flexibility information for planning the energy demand of households, in: Communications in Computers and Information science, Vol. 579, Springer, ISBN: 978-3-319-27752-3, 2015, pp. 216–236.
- [13] A. Paverd, A. Martin, I. Brown, Security and privacy in smart grid demand response systems, in: International Workshop on Smart Grid Security, Springer, 2014, pp. 1–15.
- [14] A. Molderink, V. Bakker, M.G. Bosman, J.L. Hurink, G.J. Smit, Management and control of domestic smart grid technology, *IEEE Trans. Smart Grid* 1 (2) (2010) 109–119.
- [15] O. Sundstrom, C. Binding, Flexible charging optimization for electric vehicles considering distribution grid constraints, *IEEE Trans. Smart Grid* 3 (1) (2012) 26–37.
- [16] J.A.P. Lopes, F.J. Soares, P.M.R. Almeida, Integration of electric vehicles in the electric power system, *Proc. IEEE* 99 (1) (2011) 168–183.
- [17] C. Binding, D. Dykeman, N. Ender, D. Gantenbein, F. Mueller, W.C. Rumsch, et al., FlexLast: An IT-centric solution for balancing the electric power grid, in: Industrial Electronics Society, IECON 2013–39th Annual Conference of the IEEE, IEEE, 2013, pp. 4751–4755.
- [18] T. Tušar, E. Dovgan, B. Filipic, Scheduling of flexible electricity production and consumption in a future energy data management system: problem formulation, in: Proceedings of the 14th International Multiconference Information Society IS, 2011, pp. 96–99.
- [19] M. Findrik, R. Pedersen, C. Sloth, H.P. Schwefel, E. Hasenleithner, QoS assessment of communication technologies for a smart grid power-balancing controller, in: IEEE International Energy Conference EnergyCon, 2016.
- [20] Xiang Lu, Wenye Wang, Jianfeng Ma, An empirical study of communication infrastructures towards the smart grid: Design, implementation, and evaluation, *IEEE Trans. Smart Grid* 4 (1) (2013) 170–183.
- [21] J. Groenbaek, S. Bessler, Impact and control of network QoS on smart grid controlled electrical vehicle charging, *E&J*, 11 (2014).
- [22] C. Hagerling, C. Ide, C. Wietfeld, Coverage and Capacity Analysis of Wireless M2M Technologies for Smart Distribution Grid Services; SmartGridComm 2014; 3–6 November 2014.
- [23] Zhu Ziming, S. Lambotharan, Chin Woon Hau, Fan Zhong, Overview of demand management in smart grid and enabling wireless communication technologies, *Wirel. Commun. IEEE* 19 (2012) 48–56.

- [24] Palensky Peter, Dietrich Dietmar, Demand side management: Demand response, intelligent energy systems, and smart loads, *Indust. Inform. IEEE Trans.* 7 (2011) 381–388.
- [25] <http://www.ecogrid.dk>.
- [26] Tarish Haider, Hang See Ong, Wilfried Elmenreich, A review of residential demand response of smart grid, *Renew. Sustain. Energy Rev.* 59 (2016) 166–178.
- [27] I.S. Bayram, I. Papapanagiotou, A survey on communication technologies and requirements for internet of electric vehicles, *EURASIP J. Wirel. Commun. Netw.* (2014).
- [28] W.T. Li, et al., Demand response management for residential smart grid: From theory to practice, *IEEE Access* 3 (2015) 2431–2440.
- [29] K. Kopsidas, A. Kapetanaki, V. Levi, Optimal demand response scheduling with real-time thermal ratings of overhead lines for improved network reliability, *IEEE Trans. Smart Grid* 8 (6) (2017) 2813–2825.
- [30] S.J. Kim, G.B. Giannakis, An online convex optimization approach to real-time energy pricing for demand response, *IEEE Trans. Smart Grid* 8 (6) (2017) 2784–2793.
- [31] P. Srikantha, D. Kundur, Resilient distributed real-time demand Response via Population Games, *IEEE Trans. Smart Grid* 8 (6) (2017) 2532–2543.
- [32] R. Bajool, M. Shafie-khah, A.S. Gazafroudi, J.P.S. Catalão, Mitigation of active and reactive demand response mismatches through reactive power control considering static load modeling in distribution grids, in: 2017 IEEE Conference on Control Technology and Applications, CCTA, Mauna Lani, HI, 2017, pp. 1637–1642.
- [33] W. Tushar, et al., Smart grid testbed for demand focused energy management in end user environments, *IEEE Wirel. Commun.* 23 (6) (2016) 70–80.
- [34] S. Chiaradonna, F. Di Giandomenico, J. Xiao, Quantification of the effectiveness of medium voltage control policies in smart grids, in: 17th IEEE High Assurance Systems Engineering Symposium, HASE, Jan. 2016.
- [35] M. Findrik, Kristensen. Th, Hinterhofer. Th, R.L. Olsen, H.P. Schwefel, Information-Quality based LV-Grid-Monitoring Framework and its Application to Power-Quality Control, ADHOC-NOW 2015; June 29–July 01 2015.
- [36] A. Parisio, E. Rikos, L. Glielmo, A model predictive control approach to micro-grid operation optimization, *IEEE Trans. Control Syst. Technol.* 22 (5) (2014) 1813–1827.
- [37] Gurobi Solver, online: <http://www.gurobi.com/>.
- [38] L. Gan, U. Topcu, S.H. Low, Optimal decentralized protocol for electric vehicle charging, *IEEE Trans. Power Syst.* 28 (2) (2013) 940–951.
- [39] EGEE 102, Energy conservation and Environment Protection: <https://www.education.psu.edu/egee102/>.
- [40] NORDPOOL day ahead prices: online <https://www.nordpoolgroup.com/Market-data/Dayahead/>.
- [41] C.-I. Ciontea, Rasmus Pedersen, T.I. F. Kristensen, C. Sloth, R.L. Olsen, F. Iov, Smart grid control and communication: The SmartC2Net real-time HIL approach, *IEEE PowerTech* (2015).
- [42] GSmart Datasheet: available online <http://www.efacec.pt/en/wp-content/uploads/2016/10/CS14511309B1.pdf>, accessed Feb 27, 2017.
- [43] J. Madsen, J. Pillai, H.-P. Schwefel, Resilience of urban smart grids involving multiple control loops, in: IEEE International Smart Cities Conference, ISC2: Workshop on Resilient and Secure Urban Power Systems, September 2016.
- [44] M. Findrik, J. Groenbaek, R.L. Olsen, Scheduling data access in smart grid networks utilizing context information; *SmartGridComm* 2014; 3–6 November 2014.
- [45] SmartC2Net Consortium, Final Report, online available: <http://smartc2net.eu/public-deliverables>; 30-11-2015.
- [46] G. Dondossola, R. Terruggia, Cyber security of smart grid communications: Risk analysis and experimental testing, in: *Cyber Physical Systems Approach to Smart Electric Power Grid Power Systems*, Springer, Berlin Heidelberg, 2015, pp. 169–193.

ISSN (online): 2446-1628
ISBN (online): 978-87-7210-433-1

AALBORG UNIVERSITY PRESS