



Aalborg Universitet

AALBORG UNIVERSITY  
DENMARK

## A Review on Electro-thermal Modeling of Supercapacitors for Energy Storage Applications

Wei, L.; Wu, M.; Yan, M.; Liu, Shuai; Cao, Q.; Wang, Huai

*Published in:*  
IEEE Journal of Emerging and Selected Topics in Power Electronics

*DOI (link to publication from Publisher):*  
[10.1109/JESTPE.2019.2925336](https://doi.org/10.1109/JESTPE.2019.2925336)

*Publication date:*  
2019

*Document Version*  
Accepted author manuscript, peer reviewed version

[Link to publication from Aalborg University](#)

*Citation for published version (APA):*  
Wei, L., Wu, M., Yan, M., Liu, S., Cao, Q., & Wang, H. (2019). A Review on Electro-thermal Modeling of Supercapacitors for Energy Storage Applications. *IEEE Journal of Emerging and Selected Topics in Power Electronics*, 7(3), 1677 - 1690. [8746763]. <https://doi.org/10.1109/JESTPE.2019.2925336>

### General rights

Copyright and moral rights for the publications made accessible in the public portal are retained by the authors and/or other copyright owners and it is a condition of accessing publications that users recognise and abide by the legal requirements associated with these rights.

- ? Users may download and print one copy of any publication from the public portal for the purpose of private study or research.
- ? You may not further distribute the material or use it for any profit-making activity or commercial gain
- ? You may freely distribute the URL identifying the publication in the public portal ?

### Take down policy

If you believe that this document breaches copyright please contact us at [vbn@aub.aau.dk](mailto:vbn@aub.aau.dk) providing details, and we will remove access to the work immediately and investigate your claim.

# A Review on Electro-thermal Modeling of Supercapacitors for Energy Storage Applications

Li Wei, *Member, IEEE*, Ming Wu, Mengdi Yan, Shuai Liu, Qiang Cao, and Huai Wang, *Senior Member, IEEE*

**Abstract**—Supercapacitors are drawing more and more attention in energy storage applications. This paper aims to discuss the state of the art of application-oriented electro-thermal modeling methods for supercapacitors and identify the limitations and future research opportunities. Electro-thermal modeling is essential to model-based design, thermal management, and reliability analysis of supercapacitors for energy storage applications. The review provides new perspectives with respect to existing surveys which focus mainly on materials, cell voltage balancing, electrical equivalent circuit models and energy management system. It covers the main aspects of electro-thermal modeling of Electric Double-Layer Capacitor (EDLC) and hybrid supercapacitor, from heat generation mechanisms to different modeling and parameterization approaches. The outcomes of the review are an archive of important research work in the topic area and an outlook on future efforts to be made.

**Index Terms**—Supercapacitor; Electro-thermal Modeling; Heat Generation; Heat Transfer; Model Parameterization; Energy Storage Application;

## I. INTRODUCTION

Energy storage demand is one of the biggest challenges in the progress towards better renewable energy solutions. Developing energy storage system with higher reliability, efficiency, longer life time and lower cost has been the main theme for the researchers in the field of power electronics and energy management. Supercapacitor (SC), also known as ultracapacitor, is a kind of energy storage device which has unique features such as high power density, high charging and discharging speed, long cycling life, wide working temperature and so on. Therefore, it has been attracting an increasing attention in energy storage field [1–3].

SC can be classified as Electric Double-Layer Capacitor (EDLC), pseudo-capacitor, and Hybrid SC [4], among which EDLC and Hybrid SC are two main types of commercial SC suitable for large-scale energy storage field. EDLC is

fabricated by two symmetrical carbon electrodes with high specific surface area ( $> 1000m^2 \cdot g^{-1}$ ). It has huge capacitance and high power density. With organic electrolytes, EDLC can reach an operating cell voltage of 2.7 V and a specific capacitance of 100 to 120  $F \cdot g^{-1}$  [5], whereas the energy density is relatively lower compared with batteries. Hybrid SC is designed asymmetrically with a carbon electrode and an oxide based [6] or battery type electrode [7–9]. Both Faradaic and non-Faradaic reactions exist during charging or discharging process, which will lead to larger capacitance and higher energy density. It claims that the Hybrid SC can reach an energy density of  $14Wh/kg$ , which is about 2 to 5 times higher than symmetric designs [10].

Because of its fast response time (milliseconds), fast discharge time (usually less than 1 hour) and high cycling times (normally higher than 20, 000 cycles), SC is widely used in applications such as maintenance of power quality, integration renewable smoothing intermittent, grid/network fluctuation suppression, motor starting, uninterruptible power supply, and promising in more various fields like power system protections, low voltage ride-through, transmission and distribution stability, et.al [2, 11–17]. It can be used to replace one energy storage device and play the same role, whereas cooperating with others (e.g. battery, fuel cell, compressed air energy storage) to build a hybrid energy storage system (HESS) is a more common solution [3, 18, 19]. It is also worth mentioning that Hybrid SC is very suitable as the power supply of electric bus, and the total energy consumption and cost can be reduced by 14% and 6% respectively compared with battery powered bus [20].

In energy storage fields, a large number of serial and parallel SCs are needed for the system design. Although numerous work has been carried out in developing high performance SC cells [21–24], more attention should be paid to SC system integration. The main challenge is how to design and manage the energy storage system to make sure of the reliable operation, extending the service life and achieving maintenance free. Hence, the optimized system design and management based on practical loading profiles is drawing more and more attention, such as model-based system design, electrical and thermal management, mission profile based reliability analysis and life time extension strategies.

Temperature is one of the most important factors affecting the SC performance [25–28], it will cause irreversible impacts on SC cell, such as solvent evaporation [29–31], impurities production [32], and accelerated aging [33]. Furthermore, the uneven temperature distribution inside a SC module will exacerbate the inconsistency among SC cells and result in

Manuscript received February 13, 2019; revised May 17, 2019; accepted June 9, 2019. Date of publication ..., 2019; date of current version ..., 2019. This work was supported by the National Natural Science Foundation of China (No.51777141), the Fundamental Research Funds for the Central Universities (inter-disciplinary program) under contract No. kx080020173427, the China Scholarship Council (The International Clean Energy Talent Programme, 2017), and Advanced Power Electronic Technology and Tools Project funded by Innovation Fund Denmark. (*Corresponding author: Qiang Cao.*)

Li Wei, Ming Wu, and Mengdi Yan are with the School of Electronics and Information Engineering, Tongji University, Shanghai 201804, China (e-mail: weili@tongji.edu.cn; 1730683@tongji.edu.cn; yan\_mengdi@tongji.edu.cn).

Shuai Liu and Huai Wang are with the Department of Energy Technology, Aalborg University, Aalborg 9220, Denmark (e-mail: sli@et.aau.dk; hwa@et.aau.dk).

Qiang Cao is with the School of Mechanical Engineering, Tongji University, Shanghai 201804, China (e-mail: QiangCao@tongji.edu.cn).

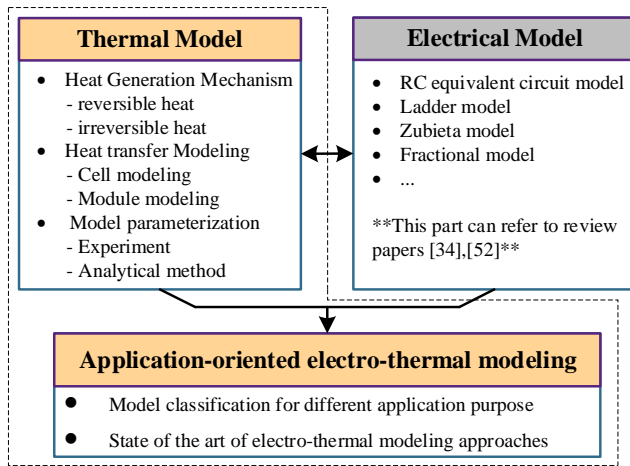

Fig. 1. The main structure of the paper. In this paper, we highlight the thermal modeling and application-oriented electro-thermal modeling approaches.

the degradation of system performance and shortening of the service life. Therefore, accurate modeling of electrical and thermal behavior of SC under a wide range of operation conditions is quite important for optimized system design and management in energy storage applications [34]. It all requires electro-thermal models for analyzing the electrical and thermal loadings, model-based sizing and design of SC stacks, thermal management and reliability study.

A number of models describing the electrical characteristics have been well developed, such as classical equivalent circuit model [35–37], ladder circuit model [38], transmission line model [39], Zubieta Model [40], artificial neural network [41–43], fractional-order models [44], and so on. However, only few works referred to the thermal effect of SC modeling [45–47]. The existing review papers about SC mainly focus on the material innovation [4, 48, 49], voltage balancing methods [50, 51], electrical equivalent modeling and characterization [34, 52], electrical characteristic management [53], and battery-SC hybrid storage system [54, 55]. Nevertheless, there is still a lack of comprehensive discussions and insights on electro-thermal modeling of SC.

The design of an optimized SC management system requires the interdisciplinary knowledge from both electrical and thermal field. The purpose of this paper is to make a comprehensive investigation in the study of SC electro-thermal modeling in energy storage system application, and the thermal study of SC will be highlighted due to the lack of related studies. The following three prominent contributions distinguish our endeavor from existing review articles [4, 34, 48–55]. First, heat generation characteristic of EDLC and Hybrid SC are discussed respectively, due to the different electrochemical mechanism. Second, we review the modeling approaches of SC cell and SC module from the prospective of thermal and electro-thermal characteristics. Third, we classify the model into three categories and discuss the application-oriented state of the art on electro-thermal modeling approaches. The electrical models of SC have been fully discussed by numerous literature, thus we won't go into details here. The main content of this paper is shown in Fig. 1.

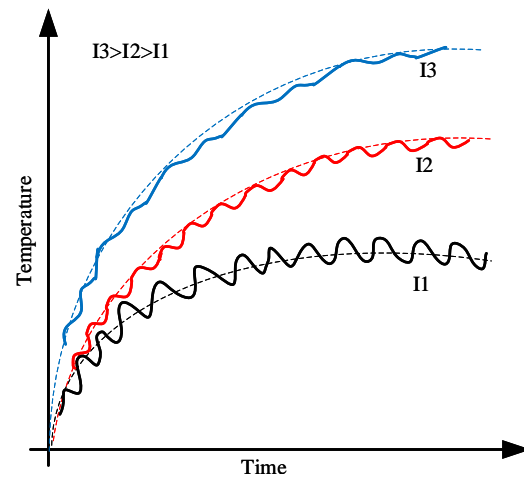

Fig. 2. Temperature fluctuations of EDLC caused by reversible heat under different current.

The paper is structured as follows: Section II discusses the characteristic of heat generation mechanism of EDLC and Hybrid SC. In Section III, heat transfer modeling has been fully discussed for SC cell and SC module with cooling. In section IV, experimental design and analytical methodology on how to acquire thermal parameters is presented. In section V, the application-oriented state of the art on electro-thermal modeling has been discussed. In section VI, an outlook for future research challenges and opportunities on electro-thermal modeling have been provided.

## II. HEAT GENERATION MECHANISM OF SC

The heat generation model defines the quantity and distribution of the generated heat caused by ionic activity joule loss inside SC. Due to the different electrochemical mechanism, the heat generation mechanism of EDLC and Hybrid SC is different. Therefore, the detailed heat generation mechanism is discussed respectively in this section.

### A. Heat generation mechanism of EDLC

The total heat generated in EDLC includes both irreversible and reversible heat. The irreversible heat is the joule heat mainly caused by the resistance of electrodes, current collector and electrolyte, and the reversible heat is due to the non-Faradaic reactions and the entropy change of ions in the electrolyte [26, 56, 57].

The reversible heat of EDLC is sometimes neglected because it was considered that the proportion of reversible heat was small compared with irreversible heat [27, 58–60]. In fact, reversible heat is the cause of temperature fluctuation, as shown in Fig. 2. The dotted line in the figure represents the temperature curve considering only irreversible heat, and the solid line represents the real temperature fluctuation. We can see that when the current is smaller, the influence of reversible heat is bigger. An explanation from micro level is that larger ion valence or diffusion coefficient will lead to smaller irreversible heat generation rate, while larger valence and smaller ion diameter will result in larger reversible heat

[61]. Thus, it is necessary to consider the reversible heat for precise modeling especially under small current [56, 57, 61–65].

The heat generation inside EDLC is non-uniform. A recent study gives a clearer picture of the reversible heat generation process [66, 67]: in the positive electrode, the charging process is exothermic and the discharging process endothermic; in the negative electrode, both exothermic and endothermic processes exist during charging and discharging.

Most of the literatures simplify the problem through the assumption of uniform heat generation for making calculation easier. With the assumption of uniform heat generation, irreversible heat  $\dot{Q}_{irev}$  can be calculated by (1):

$$\dot{Q}_{irev} = i(t)^2 ESR \quad (1)$$

where  $i(t)$  is the current of SC, and  $ESR$  is the equivalent series resistance of the first-order equivalent circuit [26, 56, 57, 62, 63].

The above method might be less accurate but the parameters are easy to get and the calculation is simple. If higher accuracy is needed, higher order equivalent circuit can be adopted. In [68], an RC series-parallel equivalent circuit model is used and the irreversible heat is calculated by (2):

$$\dot{Q}_{irev} = i^2(t)R_s + i_1^2(t)R_1 + i_2^2(t)R_2 \quad (2)$$

where  $R_s$  is the equivalent series resistance (ESR),  $R_1$  and  $R_2$  are resistance of different branch in the model,  $i(t)$  is the charging current through  $R_s$ ,  $i_1(t)$  and  $i_2(t)$  are the branch current through  $R_1$  and  $R_2$  respectively.

Another method of determining irreversible heat can be expressed as (3):

$$\dot{Q}_{irev} = j^2(r, t)/\sigma(r, t) \quad (3)$$

where  $r$  is the distance from the centerline of SC,  $j(r, t)$  is ionic current density vector which is related to valence of species, Faraday constant;  $\sigma(r, t)$  is electrolyte conductivity which is dependent on the ion diffusion coefficient in electrolyte, ion concentration of species, valence of species, temperature, etc. This method, derived from the electrochemical theory, can reflect the non-uniform heat generation mechanism, but less computationally efficient compared with the former one. Moreover, the microscopic parameters are not easy to obtain [61, 64, 65].

With the assumption of uniform heat generation, the reversible heat generation rate  $\dot{Q}_{rev}$  can be derived from Helmholtz electric double layer model [26, 56], as expressed in (4):

$$\dot{Q}_{rev} = -2 \frac{T_{abs} k}{e} \ln \left( \frac{Vol_H}{Vol_o} \right) i(t) \quad (4)$$

where  $k$  is the Boltzmann constant, the coefficient of the average kinetic energy of a molecule,  $Vol_H$  and  $Vol_o$  correspond to the volume of Helmholtz electric double layers and the volume of electrolyte in EDLC.  $\frac{Vol_H}{Vol_o}$  represents the probability of one particle to be located in electric double layers,  $e$  the value of elementary charge,  $T_{abs}$  the absolute

temperature, and the direction of current  $i(t)$  is positive during charging and negative during discharging. This method is precise enough, and has been verified by the Hamid Gualous's experiment [56]. The problem is that we should have enough structure and material information of SC to estimate  $\frac{Vol_H}{Vol_o}$ .

Based on the surface Gibbs free energy of electrolyte and energy conservation [57], another expression can be derived for calculating reversible heat generation rate with uniform heat generation assumption, as expressed in (5):

$$\dot{Q}_{rev} = -2 \frac{T_{abs} k}{ze} \ln \left( \frac{a_{\pm 2}}{a_{\pm 1}} \right) i(t) \quad (5)$$

where  $z$  is the valence of ions in electrolyte.  $a_{\pm 2}$  and  $a_{\pm 1}$  are the mean activity of ions of the electrolyte in the electric double layers and the subscript 1 and 2 denote the charging and discharging states. We can see that (4) and (5) are quite similar, although based on different derivation principle. The problem is still that we need enough electrochemical information to determine the microscopic parameters  $z$ ,  $a_{\pm 2}$  and  $a_{\pm 1}$ .

For the purpose of simplification, an empirical equation is proposed with the assumption that the reversible heat generation is proportional to current [62, 63], which can be expressed as (6):

$$\dot{Q}_{rev} = \alpha \cdot i(t) \quad (6)$$

In (6),  $\alpha$  can be calculated by  $\alpha = 2C_{th}\delta T/(IT_p)$ , where  $C_{th}$  is thermal capacitance,  $\delta T$  is the difference value of temperature oscillatory steady-state,  $I$  the current, and  $T_p$  is the cycling period, which can be easily obtained from experimental curve. However, the problem is that it is less accurate and these parameters are specific to each device.

Based on Stern electrochemical model, an expression which can describe the non-uniform heat generation process of both irreversible and reversible heat is derived [61, 64, 65]:

$$\dot{Q} = \dot{Q}_{irev}(r, t) + \dot{Q}_{E,d}(r, t) + \dot{Q}_{E,s}(r, t) + \dot{Q}_{S,c}(r, t) + \dot{Q}_{S,T}(r, t) \quad (7)$$

where  $\dot{Q}$  is the heat generation rate including both reversible and irreversible heat,  $\dot{Q}_{irev}(r, t)$  corresponds to the contributions of joule heating,  $\dot{Q}_{E,d}(r, t)$  is ion diffusion,  $\dot{Q}_{E,s}(r, t)$  denotes steric effects,  $\dot{Q}_{S,c}(r, t)$  and  $\dot{Q}_{S,T}(r, t)$  are the heat of mixing associated with ion flow along the partial molar entropy gradient, and along the temperature gradient, respectively. Here,  $\dot{Q}_{irev}(r, t)$  contributes to irreversible heat generation rate,  $\dot{Q}_{E,d}(r, t) + \dot{Q}_{E,s}(r, t) + \dot{Q}_{S,c}(r, t) + \dot{Q}_{S,T}(r, t)$  together contribute to reversible generation rate. The variable  $r$  is the distance from the centerline of SC. Although it can perfectly describe the heat generation process, the problem is that the microscopic parameters are not easy to obtain and it is suggested to use finite element numerical analysis to solve these equations.

## B. Heat generation mechanism of Hybrid SC

The heat generated in Hybrid SC also includes irreversible and reversible heat. The irreversible heat is caused by the resistance of electrodes, collectors, and electrolyte, and the calculation method can refer to that of EDLC. The reversible

heat is caused by entropy change of ions, Faradaic and non-Faradaic reaction. Because of Faradaic reaction, the proportion of reversible heat is bigger and cannot be neglected in Hybrid SC.

The total heat  $\dot{Q}$  generated in Hybrid SC can also be deduced from one-dimensional Stern electrochemical model [69], which describes the heat generation process, and expressed as:

$$\dot{Q} = - \sum_{i=0}^{n+1} N_i \frac{\partial \bar{H}_i}{\partial x} - \sum_{i=0}^{n+1} \bar{H}_i \dot{r}_i \quad (8)$$

where  $\bar{H}_i$  is the partial molar enthalpy of ion species  $i$  ( $1 \leq i \leq n$ ) or of the electrons, corresponding to  $i = n + 1$ ;  $\dot{r}_i$  is the local production rate of species  $i$  due to chemical reactions;  $x$  is the distance to the electrode;  $N_i$  is the local flux of species  $i$ . The problem is that it demands detailed structural and material information for obtaining microscopic parameters and will take up a lot of computing resources for solving partial difference equations.

For the purpose of simplification, an alternative method is proposed with the assumption of uniform heat generation [70], which can be expressed as:

$$\dot{Q} = i(t)(V_o - V_t) - i(t)T \frac{\partial V_o}{\partial T} \quad (9)$$

where  $V_o$  and  $V_t$  correspond to the open circuit voltage and the terminal voltage, respectively.  $\frac{\partial V_o}{\partial T}$  and  $T$  denote the entropy coefficient and temperature. The first part of equation represents the irreversible heat which is caused by polarization. The second part calculates the reversible heat, which may be positive or negative. Although not fully explaining the complex electrochemical processes, it is much easier to obtain the parameters and to calculate the heat generation rate which is adopted in several studies [71–73].

### C. Summary of heat generation estimation method

Table I gives a brief summary of the mentioned heat generation estimation method of EDLC and Hybrid SC. With non-uniform heat generation assumption, the heat generation process can be very well described by the partial differential equations. However, it is computationally inefficient for solving these equations, and the microscopic parameters which require a clear knowledge of the structural and material information of SC are not easy to obtain. It is more suitable for electrochemical study of SC.

With uniform heat generation assumption, the heat generation rate calculation is simplified and the equivalent macroscopic parameters are comparatively easy to acquire. Therefore, it is more suitable for using in the study of energy storage system.

## III. HEAT TRANSFER MODELING OF SC

Heat transfer model determines the temperature change across the spatially discretized cell characterized by the geometric and thermal properties. Heat transfer model includes heat convection, radiation and conduction: heat convection is

governed by the heat dissipated from the cell surface to the ambient environment which is caused by ambient fluid; heat radiation can be expressed by Stefan–Boltzmann’s law; heat conduction described by heat conduction equation can be used to estimate the temperature distribution inside the layers and on the surface of the SC [74, 75].

In this section, heat transfer modeling of SC will be discussed from the aspects of cell thermal modeling and module thermal modeling with cooling.

### A. Heat transfer modeling for SC cell

Generally, there are three kinds of heat transfer model: lumped thermal parameter model, finite difference model, and finite element model.

#### 1) Lumped thermal parameter model

By using the equivalent thermal circuit analogy, thermal model can be described by lumped thermal resistance and thermal capacitance. In [27], a simple thermal-electric analogy model which contains two lumped thermal resistance and one lumped thermal capacitance is established, shown as Fig. 3.  $T_a$  is ambient temperature,  $T_s$  is inner surface temperature of SC,  $P$  is the total power dissipated in the SC,  $R_{conv}$  represents the heat transfer between the surface of SC and the ambient air,  $R_{th}$  and  $C_{th}$  denote the thermal resistance and thermal capacitance, respectively.

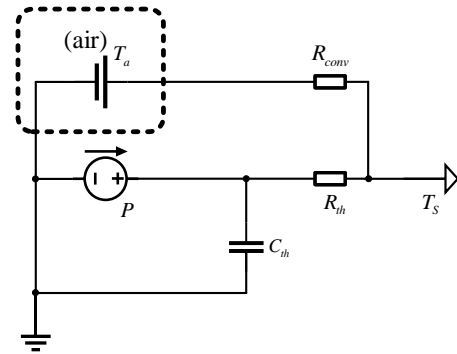

Fig. 3. Lumped thermal parameter model of the SC [27].

This first-order thermal model assumes uniform temperature distribution inside SC, which can simplify the modeling process but it is less accurate and doesn’t reflect the real temperature gradient either inside or on the surface of SC. As it doesn’t occupy too much computational resources, it is suitable for real time application such as on-line temperature observation for SC energy storage system [27, 62, 76, 77].

EDLCs are generally cylindrical structures. For describing the temperature gradients across a cylindrical EDLC, a pseudo-3D thermal model is introduced by defining thermal capacity and thermal resistance in  $x$ ,  $y$ ,  $z$  directions [78]. The  $x$  direction represents the heat transfer around the spiral in a given material; the  $y$  direction denotes the axial heat transfer between the terminals of the cell in a given material; the  $z$  direction represents the radial heat transfer across the zness of the jelly-roll between different materials, as shown in Fig. 4. The partially unwound jelly-roll with grey blocks in

TABLE I  
COMPARISON OF SC HEAT GENERATION RATE ESTIMATION METHOD

Category	Heat generation Mechanism	Heat generation Assumption	Heat generation rate Estimation	Upside	Downside	References
EDLC	Irreversible heat	Uniform	$i(t)^2 ESR$	Less computation, easy to get parameters	Less accuracy	[26, 56, 57, 62, 63]
		Uniform	$i^2(t)R_s + i_1^2(t)R_1 + i_2^2(t)R_2$	Less computation, easy to get parameters	Less accuracy	[68]
	Reversible heat	Non-uniform	$j^2(r, t)/\sigma(r, t)$	High accuracy, good in describing heat distribution	Heavy computation, difficult to get parameters	[61, 64, 65]
		Uniform	$-2 \frac{T_{abs}k}{e} \ln(\frac{V_{olH}}{V_{olo}})i(t)$	Less computation, accuracy	Less easy to get parameters	[26, 56]
		Uniform	$-2 \frac{T_{abs}k}{ze} \ln(\frac{a \pm 2}{a \pm 1})i(t)$	Less computation, accuracy	Less easy to get parameters	[57]
		Non-uniform	$\dot{Q}_{E,d}(r, t) + \dot{Q}_{E,s}(r, t) + \dot{Q}_{S,c}(r, t) + \dot{Q}_{S,T}(r, t)$	High accuracy, good in describing heat distribution	Heavy computation, difficult to get parameters	[61, 64, 65]
Hybrid SC	Irreversible heat	Uniform	$i(t)^2 ESR$	Less computation, easy to get parameters	Less accuracy	[71, 72]
		Uniform	$i(t)(V_o - V_i)$	Less computation, easy to get parameters	Less accuracy	[70]
		Non-uniform	$j^2(r, t)/\sigma(r, t)$	High accuracy, good in describing heat distribution	Heavy computation, difficult to get parameters	[69]
	Reversible heat	Uniform	$-i(t)T\partial V_o/\partial T$	Less computation, easy to get parameters	Less accuracy	[70]
		Total heat	Non-uniform	$-\sum_{i=0}^{n+1} N_i \frac{\partial \bar{H}_i}{\partial x} - \sum_{i=0}^{n+1} \bar{H}_i \dot{r}_i$	High accuracy, good in describing heat distribution	Heavy computation, difficult to get parameters

the top part illustrates the thermal model discretization (for  $n \times m$  elements), where  $ThEl$  denotes heat generated in electrode,  $REL_x$  the thermal resistance of electrode in  $x$  direction,  $REL_y$  the thermal resistance of electrode in  $y$  direction. The bottom part illustrates the heat transfer between different materials in  $z$  direction, at discretization segment ( $n-1, m$ ), where  $ThCC$  and  $ThSep$  denotes the heat generated in current collector and separator respectively,  $RCC_x$  and  $RCC_y$  the thermal resistance of current collector in  $x$  and  $y$  direction respectively,  $RSep_x$  and  $RSep_y$  the thermal resistance of separator in  $x$  and  $y$  direction respectively, and  $RCC_z$ ,  $RSep_z$ ,  $REL_z$  the thermal resistance of current collector, separator and electrode in  $z$  direction.

By discretizing the thermal model, it is possible to model 3D temperature gradients in a straightforward way. The geometric and thermal properties of each material, the air-gap between the jelly-roll and aluminum can be also accounted for. By making use of spiral symmetry, the computational cost associated with a fully discretized 3D can be also reduced. This model has higher precision and can be used for internal temperature estimation inside EDLC. Nevertheless, it is only suitable for cylindrical EDLC which has symmetrical structure.

The thermal parameters are highly dependent on the geometry of the cell. For Hybrid SC with rectangle packaging with six sides, a first-order heat transfer model comprised by six group of lumped thermal parameters is proposed [72], which is shown in Fig. 5. The thermal capacitance  $C_{th}$  and total power loss  $P$  are still based on the assumption uniform heat generation. This modeling approach can describe the different heat transfer speed to each direction caused by asymmetrical structure and Faradaic reaction of Hybrid SC, which can be used to estimate the internal and surface temperatures of each

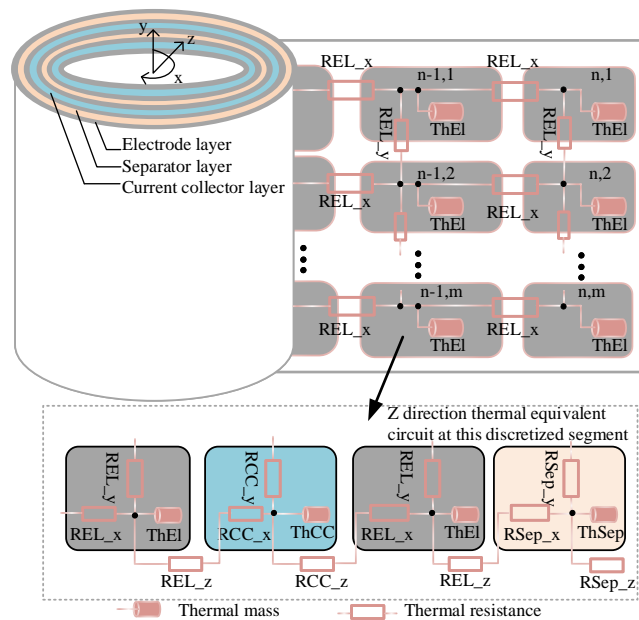

Fig. 4. Illustration of the structure and discretization of the jelly-roll in the developed pseudo-3D thermal model. The partially unwound jelly-roll with grey blocks in the top part illustrates the thermal model discretization through a single electrode in  $x$  direction. The bottom part illustrates the thermal connection between material layers in  $z$  direction at the discretization segment ( $n-1, m$ ) [78].

side. Though it doesn't reflect temperature gradient inside SC, it provides an idea of modeling rectangle packaged SC with higher precision.

## 2) Finite difference model

Finite difference model uses finite difference method to

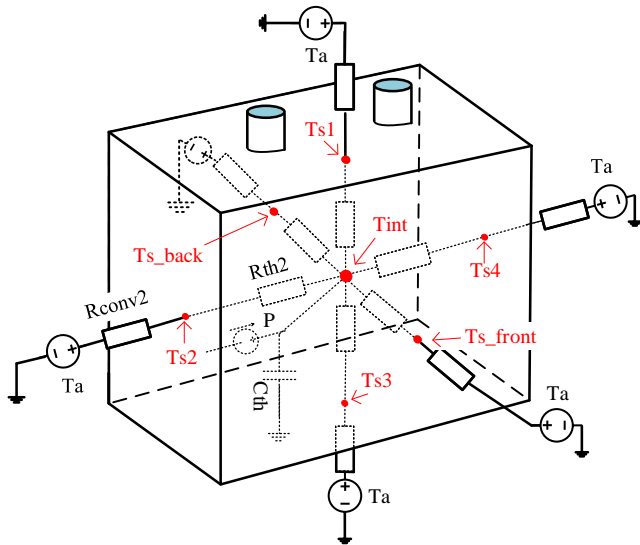

Fig. 5. First-order heat transfer model with 6 groups of lumped thermal parameters.  $T_a$  and  $T_{int}$  are the ambient and the internal temperature respectively,  $T_{s1}$ ,  $T_{s2}$ ,  $T_{s3}$ ,  $T_{s4}$ ,  $T_{s\_front}$ , and  $T_{s\_back}$  are the surface temperatures of each side,  $R_{th}(i)$  is thermal resistance from internal middle point to the side  $i$ , and  $R_{conv}(i)$  is the convective thermal resistance from side  $i$  to the environment. [72].

solve the heat-energy balance equation, which can be expressed as [75, 79]:

$$\rho C_p \cdot \frac{\partial T}{\partial t} = \lambda_x \cdot \frac{\partial^2 T}{\partial x^2} + \lambda_y \cdot \frac{\partial^2 T}{\partial y^2} + \lambda_z \cdot \frac{\partial^2 T}{\partial z^2} + \phi \quad (10)$$

where  $\rho$ ,  $C_p$ ,  $\lambda$  and  $\phi$  are the density, thermal capacity, heat conductivity and heat generation rate per unit volume, respectively.

One of the most popular methods of solving heat conduction in two or more dimensions is alternating direction method (ADI) [75, 80]. In [28], this method is used to estimate transient temperature of cylindrical structure SC with two dimensions: the axial direction and radial direction. Normally, this method can estimate the temperature distribution in both spatial and time domain. However, this model will take up too much computation resources and the accuracy is limited by the value of iteration step and boundary condition. The smaller iteration step may result in less error, but it will cause large arithmetic operations and make the situation rapidly become worse for a finer mesh [81]. With the popularity of finite element simulation software, the finite difference method has gradually been replaced.

### 3) Finite element model

Finite element model is also built by solving heat-energy balance equation, which can be simulated by ANSYS Fluent or COMSOL Multiphysics [82, 83]. In [59], a finite element thermal model with an implicit predictor-multicorrector algorithm for getting transient temperature distribution of SC is established. In [60], a three-dimensional finite element thermal model by ANSYS for SC under constant current charging and discharging is proposed.

One of the biggest advantages is that it can observe the temperature gradient of SC with high accuracy and is suitable

to deal with SC with different geometries and boundary conditions [84]. The disadvantage is that it requires large computational resources, and the selection of a proper mesh size is also important for finite element model, as a smaller mesh size may scale the relative error slightly, but sharply increase the computing time [74, 85].

In the latest released COMSOL *Multiphysics* 5.4, it has a package for simulating the electrochemical process with detailed parameter input from microscopic level, such as the properties of electrolytes, membranes, and porous electrodes, which can describe the non-uniform heat generation process inside SC. When coupled to the “heat transfer” interface, the temperature gradients can be very well displayed [82]. It is quite useful for SC designers to study the thermal characteristic from a microscopic perspective. However, due to heavy computational cost, it is not suitable for on-line temperature estimation based on embedded system.

### 4) Comparison of SC cell modeling

Table II gives a brief summary of the above mentioned heat transfer modeling method of SC. The lumped thermal parameter model, though less accurate in reflecting the temperature distribution, is suitable for on-line temperature observation based on embedded systems. Furthermore, through discretizing the lumped thermal model with certain groups of parameters, we can estimate the temperature of SC with different geometric shapes.

The finite difference models and finite element models have very good accuracy in temperature gradient description. The electrochemical heat generation process and heat transfer process can be very well displayed, which is close to the thermal behavior of real SC. It is quite suitable for SC designers in electrochemistry field. The problem is that it may be not easy for engineers from energy storage application field to acquire so many microscopic parameters of SC, and it also requires high computational capability.

## B. Heat Transfer modeling for SC module with cooling

Thermal management is drawing more and more attention in energy storage field [86–89]. Cooling design plays an important role in optimized SC module configuration which will directly impact the system performance and reliability. In this part, thermal modeling for SC module with cooling is discussed.

### 1) Thermal network model

Thermal network model is comprised by multiple lumped thermal cell models coupling with each other. Generally, it is established upon thermal energy equation:

$$C_{th} \frac{dT}{dt} = [A_{cond} + A_{conv} + A_{trans}]T + q_{gen} \quad (11)$$

It includes conduction, convection, and mass transport which reflect the forced air cooling mechanism of heat exchanges, where  $T$  is the vector of the temperature representing the terminal (inner) temperature of each element cell,  $A_{cond}$  and  $A_{conv}$  are the conduction and convection matrix that contains the thermal resistance between two thermal nodes, respectively.  $A_{trans}$  is the fluid transport matrix that contains

TABLE II  
SUMMARY OF SC CELL MODELING APPROACHES

Category	Real time	Application	Upside	Downside	References
Lumped thermal parameter models	Yes	On-line temperature monitoring and estimation	Less computation, easy to obtain parameters	Poor in temperature gradient description	[27, 62, 72, 78]
Finite difference models	No	Off-line thermal analysis	Good in temperature gradient description	Heavy computation, sensitive to boundary condition and iteration step	[28]
Finite element models	No	Off-line thermal analysis, SC cell design	Good in temperature gradient description	Heavy computation, sensitive to model structure and mesh grid, microscopic parameters needed	[59, 60, 74, 85]

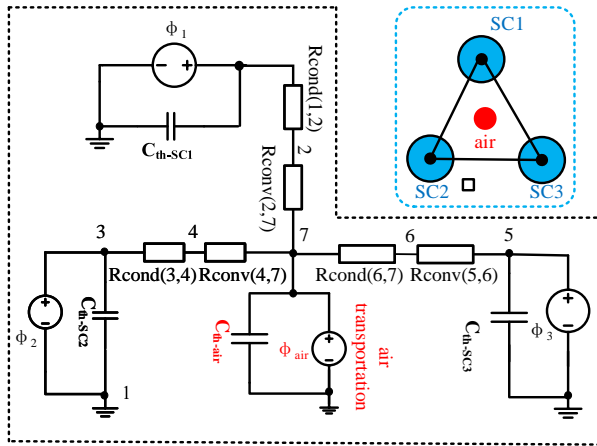

Fig. 6. Thermal network module with 3 Cells.  $C_{th-SC}$  and  $C_{th-air}$  is the thermal capacitance of SC and the air,  $R_{conv}$  and  $R_{cond}$  represent the convection and conduction thermal resistance respectively,  $\Phi$  is the heat generation rate and  $\Phi_{air}$  is the air flow rate. [90].

mass flow rate from one node to another.  $q_{gen}$  represents the heat production in each SC [90].

A thermal network model is developed with MATLAB for a module containing 20 cells which is arranged into four rows in [77]. It is used for estimating the temperature distribution inside the module and determining if the module needs a cooling system. In [90], a thermal network model with 3 cells is built, as shown in Fig. 6. To validate the model, an experiment with six cells under different air velocity (0.2 m/s, 0.23 m/s) and different rest periods (90 s, 110 s) is carried. Due to the assumption of homogeneous thermal properties of each cell, the relative error between simulation and experiment is up to 4.5%. However, this error is still acceptable with the advantage of less computation time.

Considering the forced air-cooling, a thermal network model is proposed in [76]. The heat balance equations of this model are deduced from three aspects: cell itself, cell to cell, cell to air cooling fluid. For estimating the string temperature and tracking the temperature fluctuation, a closed-loop observer is designed, and the applicability for predicting the instantaneous temperatures of each cell is further confirmed. Based on this model, on-line temperature monitoring and diagnostics can be achieved.

#### 2) Computational fluid dynamics (CFD) module

CFD model can be used to describe thermal behavior of SC module through finite element solution. It can reflect the real

temperature distribution of the module, explore the inlet and outlet of forced air and optimize the configuration of each cell for a better thermal design [91, 92].

A CFD-based model with forced air-cooling is proposed in [93], and SCs are staggered configured with three arrangement combining three ventilation power. The result shows that the staggered arrangement distribution provides better cooling performance than widely spaced ones. In [58], a 4-cell CFD module connected in series is simulated by COMSOL. The result shows that a 3mm spacing between the cell and external fan with a power of 1.7W can provide adequate cooling [71]. In [85], an 8-cell CFD module is designed with COMSOL. The simulation has been carried out with different case material (AL, PVC) and different air flow velocity, and the result shows that the temperature is lower for aluminum case than PVC, however, the temperature grad of PVC case is higher.

#### 3) Comparison of SC Module heat transfer modeling

Table III gives a brief summary on heat transfer modeling of SC module. Thermal network model, which is derived from lumped thermal parameter model, can be used to estimate the string temperature and track the temperature fluctuation inside the module. It is computationally efficient and suitable for on-line application such as state monitoring and diagnosis. The CFD module, which is simulated by finite element simulation software, can well reflect the temperature distribution inside the module in complex convection environment. It is more precise in describing temperature gradient, which is suitable for cooling design, configuration optimization and heat sink material selection.

### IV. THERMAL MODEL PARAMETERIZATION

In this section, experimental design and analytical methodology on how to acquire thermal parameters including heat generation rate, temperature distribution, thermal resistance and capacitance are presented. As the purpose of this paper is to review SC modeling from the prospective of energy storage system application, the thermal parameters discussed here are macroscopic parameters which are commonly used in system thermal modeling.

#### A. Experiment

##### 1) Heat generation rate measurement

Heat generation rate can be measured precisely by calorimeter, including both reversible and irreversible heat. It is widely used in the research of capacitors and batteries for a better



TABLE III  
SUMMARY OF SC MODULE THERMAL MODELING WITH COOLING

Category	Real time	Application	Upside	Downside	References
Thermal network model	Yes	On-line system thermal management	Computationally efficient	Poor in reflecting temperature gradient	[27, 76, 90]
CFD module model	No	Cooling design, module configuration optimization	Good in temperature gradient description	Heavy computation, sensitive to model structure and mesh grid	[9, 71, 85]

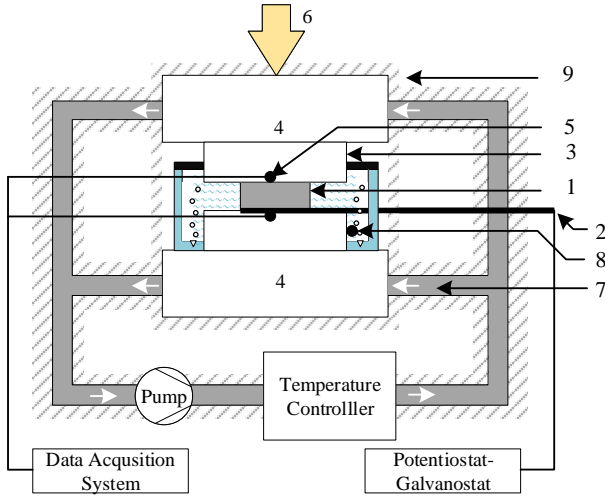

Fig. 7. Schematic of the calorimeter: (1) electrochemical cell under test, (2) current collectors, (3) heat-flux sensor, (4) cold plate, (5) thermocouples, (6) force sensor 0–200  $kg \cdot cm^{-2}$ , (7) cooling fluid, (8) electrolyte bath bubbled with nitrogen, and (9) thermal insulation. [66].

understanding of electrochemical process [94–97]. In [67], calorimetric technique is used to measure heat generated inside an EDLC under cycling. In [58], the time-dependent heat profiles of symmetric and asymmetric aqueous electrochemical capacitors with  $C-C$  and  $C-MnO_2$  electrode under cycling is measured by calorimeter.

In [66], an isothermal calorimeter is designed to measure the instantaneous heat generation rates of anode and cathode of EDLC devices under galvanostatic cycling, as shown in Fig. 7. The heat generation rate can be calculated by the following equation:

$$\dot{Q}_i(t) = \frac{\Delta V_i(t)}{S_i} A_i \quad (12)$$

where  $\Delta V_i(t) (\mu V)$  is the voltage difference delivered by heat-flow sensor at positive or negative electrode,  $A_i (cm^2)$  is the area of the negative or positive electrode,  $S_i (\mu V / (mW/cm^2))$  is sensor's temperature-dependent sensitivity. The instantaneous reversible heat generation rate  $\dot{Q}_{rev,i}(t)$  at each electrode can be evaluated by subtracting the averaged heat generation rate  $\bar{\dot{Q}}_i(t)$  from the instantaneous heat generation rate  $\dot{Q}_i(t)$  [66].

## 2) Temperature measurement

Temperature can be measured by thermocouple and thermal imager [68, 78, 90, 98–100]. The outside temperature can be easily detected by placing a thermocouple, and the surface temperature distribution can be observed by thermal image.

The internal temperature is more difficult to obtain because placing thermocouple without changing the inside property of SC is not easy. In [90], the temperature of positive electrode was used to represent the internal temperature of SC, which offers a simple but less accurate approach.

In order to detect the internal temperature distribution of SC, four Chromel-Alumel micro thermocouples were placed in different turns of jelly roll of a cylinder SC along the radial directions [27, 56]. The placing of thermocouples into the jelly roll will change the characteristics of the test cell, because the resistance and radial temperature gradient between the core and surface of the cell are increased according to [78]. It is still meaningful for the verification of the internal temperature of thermal model.

## B. Thermal resistance and capacitance parameterization

If material and structural parameters are known, thermal resistance and capacitance can be derived directly [57, 60, 62, 74, 85]. The lumped thermal parameters  $R_{conv}$ ,  $R_{th}$ ,  $C_{th}$  for a cylinder SC (shown in Fig. 8) can be obtained by the following equations [27]:

$$R_{conv} = \frac{1}{hS} \quad (13)$$

$$R_{th} = R_{insulating\_layer} + R_{metal\_case} + \sum_{i=1}^n R_{th\_i} \quad (14)$$

$$C_{th} = C_{insulating\_layer} + C_{metal\_case} + \sum_{i=1}^n C_{th\_i} \quad (15)$$

where  $h$  is the convection coefficient,  $S$  is the surface area of SC,  $R_{metal\_case}$  and  $R_{insulating\_layer}$  are the thermal resistance of the metal case and insulating layer respectively,  $C_{metal\_case}$  and  $C_{insulating\_layer}$  are heat capacity of the metal case and insulating layer respectively, and 'n' is the number of layers.  $R_{th}$  and  $C_{th}$  can be derived by the summation of all layers thermal resistance or heat capacity parameters which are acquired from materials datasheet.

As the material data might be difficult to acquire especially for commercial SCs because of business secrets, some researchers estimate thermal parameters with empirical equations from experimental data. In [65, 99], the heat capacitance  $C_{th}$  is estimated from the heat generation and the temperature rise obtained from the adiabatic case in a very short time. This is expressed as (16):

$$C_{th} = \frac{\Delta Q}{\Delta T} \quad (16)$$

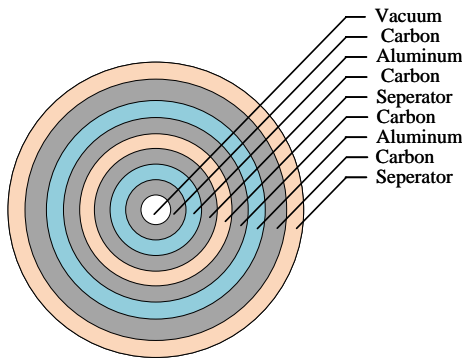

Fig. 8. Simplified SC thermal model construction: cross section of SC layers [27].

where  $\Delta Q$  is joule loss and  $\Delta T$  is the temperature change in that short time.

Another estimation method is proposed by [90], the internal thermal resistance  $R_{th}$  and the convection thermal resistance  $R_{conv}$  are estimated by steady state temperatures at two points of SC. One was the positive terminal temperature which was regarded as core temperature, the other was surface case temperature. So the thermal resistances can be deduced from:

$$R_{th} = \frac{T_{terminal} - T_{case}}{Q} \quad (17)$$

$$R_{conv} = \frac{T_{case} - T_a}{Q} \quad (18)$$

where  $T_a$  is the ambient temperature,  $T_{case}$  is the temperature of the surface of SC case, and  $T_{terminal}$  is the temperature of anode which is considered to be the same as the core's temperature of SC.

The thermal capacity of the SC is identified by the thermal time constant  $\tau$ , which was determined from the curve of the temperature drooping characteristics of SC. Therefore, the thermal capacity  $C_{th}$  can be determined by:

$$C_{th} = \frac{\tau}{R_{th} + R_{conv}} \quad (19)$$

The parameter identification methods can also be used to determine the thermal parameters [98, 101, 102], such as least square method, difference revolution, etc. Through these methods higher precision result could be obtained.

### C. Summary of thermal model parameterization

From the above discussion, we can make a summary of the existing thermal parameter acquisition methods.

Heat generation rate can be directly measured by calorimeter precisely, which can be used as a verification of heat generation approaches introduced in section III, or an alternative method to obtain heat generation rate when the detailed structural and material parameters of SC are unknown.

For practical application, the measurement of internal temperature of SC is still a challenge as placing thermocouple without changing the inside property of SC is not easy. Thus, it would be very meaningful to develop internal temperature observation method for on-line SC temperature diagnosis.

Thermal resistance and capacitance can be estimated by empirical equations which is easy but less accurate. Through parameter identification method, we can obtain thermal resistance and capacitance with higher resolution.

## V. DISCUSSION ON APPLICATION-ORIENTED ELECTRO-THERMAL MODELING OF SC

In this section, we will have an analysis and recommendation of electro-thermal modeling of SC for energy storage application. Firstly, we classify the models into three categories according to different application purpose. Then, we summary the state of the art of application-oriented electro-thermal modeling approaches accordingly.

### A. Model classification for different application purpose

As different application purpose has different requirement on accuracy, complexity, and function of the model, we classify the electro-thermal models into three categories accordingly:

#### 1) Model type I: On-line state monitoring and diagnosis

It refers to models suitable for on-line application with the purpose of real time state monitoring and diagnosis of SC. These models are often operated on embedded systems with limited computation capability, which is widely used in energy storage applications, such as in hybrid vehicle, etc.

#### 2) Model type II: Off-line system level thermal design

It refers to models suitable for system level research such as the integration of SC energy storage system into a micro grid and studying the control strategy, dynamic behavior, efficiency, etc. These off-line models often run on computer or workstation with powerful computation capability, and simulated by software like Matlab.

#### 3) Model type III: Off-line supercapacitor module level thermal design

It refers to models suitable for energy storage system integration such as thermal management, optimized SC configuration, cooling design, etc.

### B. State of the art on electro-thermal modeling

A general schematic diagram of the electro-thermal model for energy storage application is given by Fig. 9 It consists of three main parts: an electrical model describing the electrical behavior, a heat generation model calculating the heat generated inside the SC, and a heat transfer model predicting the temperature distribution. The three parts are distinct yet coupling with each other: the electrical parameters are dependent on the temperature from the thermal model, and thermal model is also influenced by the electrical parameters. The input of the electro-thermal model is the working profile generally including the current  $I$ , voltage  $U$ , ambient temperature  $T_{ambient}$ , and cooling method, and the output of this model is supposed to be SOC (State of Charge), SOP (State of Power), SOE (State of Energy), SOH (State of Health) estimation and temperature distribution inside and outside the cell.

As the electrical models of SC, such as classical equivalent circuit model, ladder circuit model, fractional-order model,

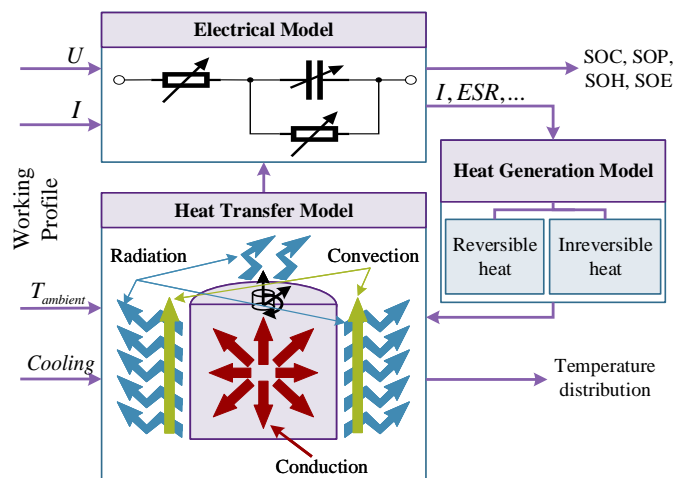

Fig. 9. Schematic of electro-thermal model of SC for energy storage applications [27].

and Zubieta Model, have been fully discussed by numerous literature [37, 38, 40, 44], we won't go into details in this paper.

When establishing the electro-thermal model, we should firstly figure out the need of the specific application and select the model type accordingly, and then we choose a proper electrical model coupled with a thermal model with the consideration of precision, complexity, computation cost, etc. The state of the art on electro-thermal modeling of SC is summarized in Fig .10 .

1) Electro-thermal modeling approaches of Model type I

As the purpose is for on-line application operated by embedded systems with limited computation capability, the model shall be simple and computationally efficient which is fit for on-line calculation. These kinds of models are suitable for on-line monitoring and the internal temperature estimation of SC.

Generally speaking, a lumped equivalent electric circuit model coupled with lumped thermal model is suggested. Because of the limited computation capability, it is not suggested to use higher order models. The electrical model could be a first or second order classical  $RC$  equivalent circuit model [36]. The heat generation model shall be built upon the assumption of uniform heat generation, and the heat transfer model is a first-order model with one or more groups of thermal parameters [72]. In [98], an electro-thermal model consisting of a first-order electric circuit model and a first-order thermal model is proposed. The coupling of the two models enables tuning of the temperature-dependent parameters of the electrical model in real time.

With the price going down of embedded system with higher computational capability, it is well worth trying higher order electro-thermal models and testing the computational cost.

2) Electro-thermal modeling approaches of Model type II

This kind of model is used to study the performance of SC system such as efficiency, dynamic behavior, and control strategy under different working profiles. With powerful computational platform, higher precision electro-thermal model

can be established.

The electrical model can be tried with a higher order equivalent electric circuit model [103], fractional order model [44], or Zubieta Model [40] which can better describe the dynamic behavior of SC. The heat generation model of SC is suggested to build upon the assumption of uniform heat generation, and the heat generated by the contact resistance and cables between SCs shouldn't be ignored. The heat transfer model can be a higher order model with several group of parameters or discretized lumped thermal model considering the SC geometric structure which could reflect the temperature gradients [78]. The effect of temperature on electrical parameters can be achieved through look-up table method.

There could be different combinations of electrical model and thermal model. If you want to study more about the electrical behavior, it can be a high order electrical model coupled with a simple thermal model, or vice versa. The trade-off between simulation speed and accuracy for the electro-thermal model should be considered.

3) Electro-thermal modeling approaches of Model type III

This kind of model is used for optimized SC configuration and cooling design. It shall be a 3D model reflecting temperature gradients, which can be simulated by finite element simulation software like COMSOL.

The non-uniform heat generation process can be well described by COMSOL as long as the microscopic parameters like the properties of electrolytes, membranes, and porous electrodes are provided. If these parameters can not be obtained, uniform heat generation can be also processed but the accuracy will be reduced. Heat generation model can be coupled to the "heat transfer" interface of the software, and hence the temperature gradients both inside and outside SC can be displayed. In COMSOL, thermal model is coupled to electrochemical model. The effect of temperature on electrochemical model is reflected in the diffusion coefficient and conductivity of the positive and negative electrodes and the electrolyte [104].

VI. CONCLUSION

Electro-thermal modeling of SC under a wide range of operation conditions is essential for optimized system design and management in energy storage applications, such as model based sizing and design of SC stacks, thermal management, mission-profile based reliability analysis, etc. This paper presents a comprehensive survey on electro-thermal modeling of SC from the aspect of heat generation, heat transfer, thermal model parameterization and the state of the art on application-oriented electro-thermal modeling.

From the discussion in the previous sections, an outlook on outstanding challenges and future research opportunities can be summarized as follows:

1) Existing modeling for SC rarely considers long-term environmental and operation conditions (e.g., mission profile), which is quite relevant to applications, such as electric bus, etc. How to model the long-term thermal loading profiles in a computational-efficient manner is a great challenge.

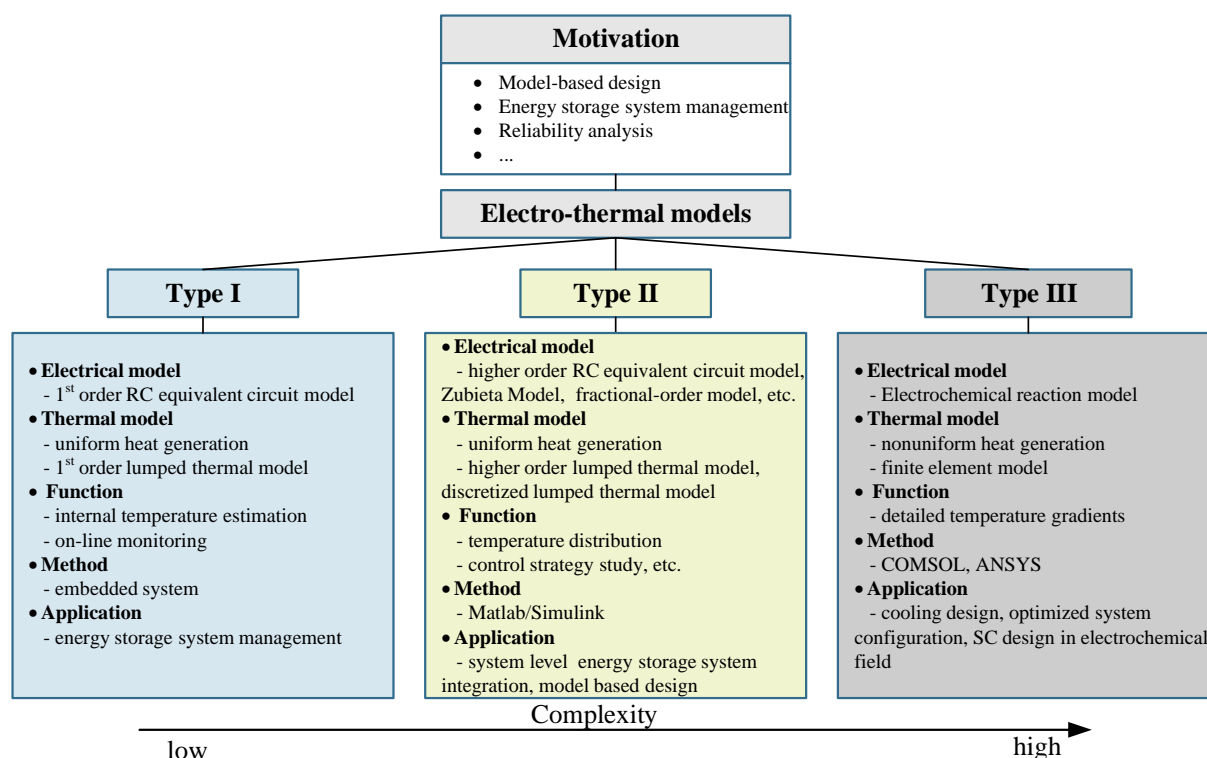

Fig. 10. State of the art on application-oriented electro-thermal modeling.

2) The existing heat generation and heat transfer model are either over simplified or complicated for practical application. Future study can be made on heat generation and heat transfer model of EDLC and Hybrid SC under practical loading profiles, especially on how to construct the model reflecting the heat generation and transfer mechanism in a simple but rational way.

3) The construction of electro-thermal model is dependent on the requirement of application field. The author has summarized the application field as three categories: on-line application for state monitoring and diagnosis, off-line application for system integration research, off-line research for thermal management and cooling design. It is difficult to develop a universal electro-thermal model suitable for all application field. Further research can be focused on developing different application oriented electro-thermal models with different combination of electrical and thermal models.

4) Simplification and calculation efficiency is always with the vital importance in practical application, especially for real-time operation for energy storage system. An optimized electro-thermal SC model suitable for on-line application should be further studied. Though the present embedded hardware may limit the realization of complex algorithms, the advanced hardware with higher calculation capability like GPU could be an option.

5) Cooling design is also a very important part for optimized SC cell configuration. So far only few studies have referred to the air cooling and configuration optimization of SC module. Liquid cooling or phase change materials cooling can be further studied.

As different industry sectors have put an increasing effort to

collect mission profile data of their products, which provides a more realistic input data for the electro-thermal modeling of SC cells and modules. At the same time, multi-time scale and multi-physical modeling methods have been proposed for other electronic components, such as power semiconductor devices and modules, electrolytic capacitor banks, etc., which could provide inspirations for the electro-thermal modeling work on SCs.

#### REFERENCES

- [1] R. Kötz and M. Carlen, "Principles and applications of electrochemical capacitors," *Electrochimica Acta*, vol. 45, no. 15, pp. 2483–2498, May 2000.
- [2] J. S. Martinez, D. Hissel, M.-C. Pera, and M. Amiet, "Practical control structure and energy management of a testbed hybrid electric vehicle," *IEEE Transactions on Vehicular Technology*, vol. 60, no. 9, pp. 4139–4152, Nov. 2011.
- [3] A. Burke, "Ultracapacitors: Why, how, and where is the technology," *Journal of power sources*, vol. 91, no. 1, pp. 37–50, Nov. 2000.
- [4] A. González, E. Goikolea, J. A. Barrena, and R. Mysyk, "Review on supercapacitors: Technologies and materials," *Renewable and Sustainable Energy Reviews*, vol. 58, pp. 1189–1206, May 2016.
- [5] J. Fernández, T. Morishita, M. Toyoda, M. Inagaki, F. Stoeckli, and T. Centeno, "Performance of mesoporous carbons derived from poly(vinyl alcohol) in electrochemical capacitors," *Journal of Power Sources*, vol. 175, no. 1, pp. 675–679, Jan. 2008.
- [6] A. Malak-Polaczyk, C. Matei-Ghimbeu, C. Vix-Guterl, and E. Frackowiak, "Carbon/  $\lambda$ -MnO<sub>2</sub> composites for supercapacitor electrodes," *Journal of Solid State Chemistry*, vol. 183, no. 4, pp. 969–974, Apr. 2010.
- [7] A. L. Brisse, P. Stevens, G. Toussaint, O. Crosnier, and T. Brousse, "Ni(OH)<sub>2</sub> and NiO based composites: Battery type electrode materials for hybrid supercapacitor devices," *Materials*, vol. 11, no. 7, Jul. 2018.
- [8] S. Vijayakumar, S. Nagamuthu, and K. S. Ryu, "CuCo<sub>2</sub>O<sub>4</sub> flowers/Ni-foam architecture as a battery type positive electrode for high performance hybrid supercapacitor applications," *Electrochimica Acta*, vol. 238, pp. 99–106, Jun. 2017.

- [9] H. Wang, M. Liang, D. Duan, W. Shi, Y. Song, and Z. Sun, "Rose-like  $\text{Ni}_3\text{S}_4$  as battery-type electrode for hybrid supercapacitor with excellent charge storage performance," *Chemical Engineering Journal*, Oct. 2018.
- [10] A. Belyakov, "Asymmetric electrochemical supercapacitors with aqueous electrolytes," *ESSCAP, November 6*, vol. 7, 2008.
- [11] P. Thounthong, "Model based-energy control of a solar power plant with a supercapacitor for grid-independent applications," *IEEE Transactions on Energy Conversion*, vol. 26, no. 4, pp. 1210–1218, Dec. 2011.
- [12] A.-L. Allègre, A. Bouscayrol, P. Delarue, P. Barrade, E. Chattot, and S. El-Fassi, "Energy storage system with supercapacitor for an innovative subway," *IEEE Transactions on Industrial Electronics*, vol. 57, no. 12, pp. 4001–4012, Dec. 2010.
- [13] Z. Cabrane, M. Ouassaid, and M. Maaroufi, "Analysis and evaluation of battery-supercapacitor hybrid energy storage system for photovoltaic installation," *International Journal of Hydrogen Energy*, vol. 41, no. 45, pp. 20897–20907, Dec. 2016.
- [14] T. Ma, H. Yang, and L. Lu, "Development of hybrid battery-supercapacitor energy storage for remote area renewable energy systems," *Applied Energy*, vol. 153, pp. 56–62, Sep. 2015.
- [15] R. E. Araujo, R. de Castro, C. Pinto, P. Melo, and D. Freitas, "Combined sizing and energy management in evs with batteries and supercapacitors," *IEEE Transactions on Vehicular Technology*, vol. 63, no. 7, pp. 3062–3076, Apr. 2014.
- [16] J. Marie-Francoise, H. Gualous, R. Outbib, and A. Berthon, "42 V power net with supercapacitor and battery for automotive applications," *Journal of Power Sources*, vol. 143, no. 1-2, pp. 275–283, Apr. 2005.
- [17] X. Luo, J. Wang, M. Dooner, and J. Clarke, "Overview of current development in electrical energy storage technologies and the application potential in power system operation," *Applied energy*, vol. 137, pp. 511–536, Jan. 2015.
- [18] P. K. S. Roy, H. B. Karayaka, Y. Yan, and Y. Alqudah, "Investigations into best cost battery-supercapacitor hybrid energy storage system for a utility scale pv array," *Journal of Energy Storage*, vol. 22, pp. 50–59, Apr. 2019.
- [19] R. Hemmati and H. Saboori, "Emergence of hybrid energy storage systems in renewable energy and transport applications—a review," *Renewable and Sustainable Energy Reviews*, vol. 65, pp. 11–23, Nov. 2016.
- [20] S. Science and T. C. (STCSM), *A non-stop route to collaborative discovery*, <https://www.nature.com/articles/d42473-018-00310-x?from=timeline&isappinstalled=0>, Accessed December 9, 2018, 2018.
- [21] D. Linzen, S. Buller, E. Karden, and R. W. De Doncker, "Analysis and evaluation of charge-balancing circuits on performance, reliability, and lifetime of supercapacitor systems," *IEEE transactions on industry applications*, vol. 41, no. 5, pp. 1135–1141, Sep. 2005.
- [22] D. Vališ, O. Nováček, K. Hasilová, and J. Leuchter, "Modelling of degradation and a soft failure moment during the operation of a supercapacitor applying selected diffusion processes," *Engineering Failure Analysis*, vol. 82, pp. 566–582, Dec. 2017.
- [23] M. Salari, B. G. Cooper, H. Zhang, and M. W. Grinstaff, "Synthesis of an environmentally friendly alkyl carbonate electrolyte based on glycerol for Lithium-ion supercapacitor operation at 100 °C," *Advanced Sustainable Systems*, vol. 1, no. 8, p. 1700067, Jul. 2017.
- [24] S. Shili, A. Hijazi, A. Sari, X. Lin-Shi, and P. Venet, "Balancing circuit new control for supercapacitor storage system lifetime maximization," *IEEE Transactions on Power Electronics*, vol. 32, no. 6, pp. 4939–4948, Jun. 2017.
- [25] M. Ayadi, O. Briat, A. Eddahech, R. German, G. Coquery, and J. M. Vinassa, "Thermal cycling impacts on supercapacitor performances during calendar ageing," *Microelectronics Reliability*, vol. 53, no. 9-11, pp. 1628–1631, Sep.-Nov. 2013.
- [26] J. Schiffer, D. Linzen, and D. U. Sauer, "Heat generation in double layer capacitors," *Journal of Power Sources*, vol. 160, no. 1, pp. 765–772, Sep. 2006.
- [27] M. A. Sakka, H. Gualous, J. V. Mierlo, and H. Culcu, "Thermal modeling and heat management of supercapacitor modules for vehicle applications," *Journal of Power Sources*, vol. 194, no. 2, pp. 581–587, Dec. 2009.
- [28] H. Gualous, H. Louahliagualous, R. Gallay, and A. Miraoui, "Supercapacitor thermal modeling and characterization in transient state for industrial applications," *IEEE Transactions on Industry Applications*, vol. 45, no. 3, pp. 1035–1044, May-Jun. 2009.
- [29] D. Torregrossa and M. Paolone, "Modelling of current and temperature effects on supercapacitors ageing. Part I: Review of driving phenomenology," *Journal of Energy Storage*, vol. 5, pp. 85–94, Feb. 2016.
- [30] M. Ayadi, O. Briat, R. Lallemand, A. Eddahech, R. German, G. Coquery, and J. M. Vinassa, "Description of supercapacitor performance degradation rate during thermal cycling under constant voltage ageing test," *Microelectronics Reliability*, vol. 54, no. 9-10, pp. 1944–1948, Sep.-Oct. 2014.
- [31] M. Ayadi, O. Briat, R. Lallemand, G. Coquery, and J. M. Vinassa, "Influence of thermal cycling on supercapacitor performance fading during ageing test at constant voltage," in *IEEE International Symposium on Industrial Electronics*, Jun. 2014, pp. 1823–1828.
- [32] D. Torregrossa and M. Paolone, "Modelling of current and temperature effects on supercapacitors ageing. Part II: State-of-health assessment," *Journal of Energy Storage*, vol. 5, no. 4955, pp. 95–101, Feb. 2016.
- [33] H. Gualous, R. Gallay, G. Alcicek, B. Tala-Ighil, A. Oukaour, B. Boudart, and P. Makany, "Supercapacitor ageing at constant temperature and constant voltage and thermal shock," *Microelectronics Reliability*, vol. 50, no. 9, pp. 1783–1788, Sep.-Nov. 2010.
- [34] L. Zhang, X. Hu, Z. Wang, F. Sun, and D. G. Dorrell, "A review of supercapacitor modeling, estimation, and applications: A control/management perspective," *Renewable and Sustainable Energy Reviews*, vol. 81, pp. 1868–1878, Jan. 2018.
- [35] R. L. Spyker and R. M. Nelms, "Classical equivalent circuit parameters for a double-layer capacitor," *IEEE transactions on aerospace and electronic systems*, vol. 36, no. 3, pp. 829–836, Jul. 2000.
- [36] L. Du, "Study on supercapacitor equivalent circuit model for power electronics applications," in *2009 2nd International Conference on Power Electronics and Intelligent Transportation System (PEITS)*, vol. 2, Dec. 2009, pp. 51–54.
- [37] Z. M. Salameh, "Performance evaluation of a supercapacitor module for energy storage applications," in *2008 IEEE Power and Energy Society General Meeting-Conversion and Delivery of Electrical Energy in the 21st Century*, IEEE, Jul. 2008, pp. 1–7.
- [38] S. Buller, E. Karden, D. Kok, and R. De Doncker, "Modeling the dynamic behavior of supercapacitors using impedance spectroscopy," in *Industry Applications Conference, 2001. Thirty-Sixth IAS Annual Meeting. Conference Record of the 2001 IEEE*, IEEE, vol. 4, Dec. 2002, pp. 2500–2504.
- [39] R. De Levie, "On porous electrodes in electrolyte solutions: I. capacitance effects," *Electrochimica Acta*, vol. 8, no. 10, pp. 751–780, Oct. 1963.
- [40] L. Zubieta and R. Bonert, "Characterization of double-layer capacitors for power electronics applications," *IEEE Transactions on Industry Applications*, vol. 36, no. 1, pp. 199–205, Jan./Feb. 2000.
- [41] Q. K. Wang, Y. J. He, J. N. Shen, Z. F. Ma, and G. B. Zhong, "A unified modeling framework for lithium-ion batteries: An artificial neural network based thermal coupled equivalent circuit model approach," *Energy*, vol. 138, Nov. 2017.
- [42] C. C. O'Gorman, D. Ingersoll, R. G. Jungst, and T. L. Paez, "Artificial neural network simulation of battery performance," in *Hawaii International Conference on System Sciences*, Jan. 1998.
- [43] A. Soualhi, A. Sari, H. Razik, P. Venet, G. Clerc, R. German, O. Briat, and J. M. Vinassa, "Supercapacitors ageing prediction by neural networks," in *Industrial Electronics Society, IECON 2013 - Conference of the IEEE*, Jan. 2014, pp. 6812–6818.
- [44] W. Mitkowski and P. Skruch, "Fractional-order models of the supercapacitors in the form of rc ladder networks," *Bulletin of the Polish Academy of Sciences: Technical Sciences*, vol. 61, no. 3, pp. 581–587, Oct. 2013.
- [45] H. Gualous, D. Bouquain, A. Berthon, and J. Kauffmann, "Experimental study of supercapacitor serial resistance and capacitance variations with temperature," *Journal of power sources*, vol. 123, no. 1, pp. 86–93, Sep. 2003.
- [46] S. A. Khateeb, S. Amiruddin, M. Farid, J. R. Selman, and S. Al-Hallaj, "Thermal management of li-ion battery with phase change material for electric scooters: Experimental validation," *Journal of Power Sources*, vol. 142, no. 1, pp. 345–353, Mar. 2005.
- [47] R. Kötz, M. Hahn, and R. Gallay, "Temperature behavior and impedance fundamentals of supercapacitors," *Journal of Power Sources*, vol. 154, no. 2, pp. 550–555, Mar. 2006.
- [48] S. Z. S. Iro C. Subramani, "A brief review on electrode materials for supercapacitor," *International Journal of Electrochemical science*, vol. 11, pp. 10628–10643, Nov. 2016.

- [49] Q. Ke and J. Wang, "Graphene-based materials for supercapacitor electrodes—a review," *Journal of Materiomics*, vol. 2, no. 1, pp. 37–54, Mar. 2016.
- [50] Y. Qu, J. Zhu, J. Hu, and B. Holliday, "Overview of supercapacitor cell voltage balancing methods for an electric vehicle," in *ECCE Asia Downunder (ECCE Asia)*, 2013 IEEE, IEEE, Jun. 2013, pp. 810–814.
- [51] S. Lambert, V. Pickert, J. Holden, W. Li, and X. He, "Overview of supercapacitor voltage equalisation circuits for an electric vehicle charging application," in *Vehicle Power and Propulsion Conference (VPPC)*, 2010 IEEE, IEEE, Sep. 2010, pp. 1–7.
- [52] N. Devillers, S. Jemei, M.-C. Péra, D. Bienaimé, and F. Gustin, "Review of characterization methods for supercapacitor modelling," *Journal of Power Sources*, vol. 246, pp. 596–608, Jan. 2014.
- [53] L. Zhang, X. Hu, Z. Wang, "Review of characterization methods for supercapacitor modelling," *Journal of Mechanical Engineering*, vol. 53, no. 16, pp. 32–43, 69, Sep. 2017.
- [54] W. Jing, C. H. Lai, S. H. W. Wong, and M. L. D. Wong, "Battery-supercapacitor hybrid energy storage system in standalone DC microgrids: A review," *IET Renewable Power Generation*, vol. 11, no. 4, pp. 461–469, Mar. 2016.
- [55] I. Chotia and S. Chowdhury, "Battery storage and hybrid battery supercapacitor storage systems: A comparative critical review," in *Innovative Smart Grid Technologies-Asia (ISGT ASIA)*, 2015 IEEE, IEEE, Jan. 2016, pp. 1–6.
- [56] H. Gualous, H. Louahlia, and R. Gallay, "Supercapacitor characterization and thermal modelling with reversible and irreversible heat effect," *IEEE Transactions on Power Electronics*, vol. 26, no. 11, pp. 3402–3409, Apr. 2011.
- [57] X. Zhang, W. Wang, J. Lu, L. Hua, and J. Heng, "Reversible heat of electric double-layer capacitors during galvanostatic charging and discharging cycles," *Thermochimica Acta*, vol. 636, pp. 1–10, Jul. 2016.
- [58] Y. Dandeville, P. Guillemet, Y. Scudeller, O. Crosnier, L. Athouel, and T. Brousse, "Measuring time-dependent heat profiles of aqueous electrochemical capacitors under cycling," *Thermochimica Acta*, vol. 526, no. 1, pp. 1–8, Nov. 2011.
- [59] D. H. Lee, U. S. Kim, C. B. Shin, B. H. Lee, B. W. Kim, and Y. H. Kim, "Modelling of the thermal behaviour of an ultracapacitor for a 42-v automotive electrical system," *Journal of Power Sources*, vol. 175, no. 1, pp. 664–668, Jan. 2008.
- [60] W. Kai, Z. Li, B. Ji, and J. Yuan, "The thermal analysis on the stackable supercapacitor," *Energy*, vol. 59, no. Complete, pp. 440–444, Sep. 2013.
- [61] A. L. D'Entremont and L. Pilon, "Thermal effects of asymmetric electrolytes in electric double layer capacitors," *Journal of Power Sources*, vol. 273, pp. 196–209, Jan. 2015.
- [62] J. Lee, J. Yi, D. Kim, C. B. Shin, K. S. Min, J. Choi, and H. Y. Lee, "Modeling of the electrical and thermal behaviors of an ultracapacitor," *Energies*, vol. 7, no. 12, pp. 8264–8278, Dec. 2014.
- [63] A. D'Entremont and L. Pilon, "First-order thermal model of commercial edlcs," *Applied Thermal Engineering*, vol. 67, no. 1-2, pp. 439–446, Jun. 2014.
- [64] A. D'Entremont and L. Pilon, "Scaling laws for heat generation and temperature oscillations in edlcs under galvanostatic cycling," *International Journal of Heat & Mass Transfer*, vol. 75, no. 4, pp. 637–649, Aug. 2014.
- [65] A. D'Entremont and L. Pilon, "First-principles thermal modeling of electric double layer capacitors under constant-current cycling," *Journal of Power Sources*, vol. 246, no. 3, pp. 887–898, Jan. 2014.
- [66] O. Munteshari, J. Lau, A. Krishnan, B. Dunn, and L. Pilon, "Isothermal calorimeter for measurements of time-dependent heat generation rate in individual supercapacitor electrodes," *Journal of Power Sources*, vol. 374, pp. 257–268, Jan. 2018.
- [67] C. Pascot, Y. Dandeville, Y. Scudeller, P. Guillemet, and T. Brousse, "Calorimetric measurement of the heat generated by a double-layer capacitor cell under cycling," *Thermochimica Acta*, vol. 510, no. 1, pp. 53–60, Oct. 2010.
- [68] C. J. Chiang, J. L. Yang, and W. C. Cheng, "Temperature and state-of-charge estimation in ultracapacitors based on extended kalman filter," *Journal of Power Sources*, vol. 234, no. 21, pp. 234–243, Jul. 2013.
- [69] A. L. D'Entremont and L. Pilon, "First-principles thermal modeling of hybrid pseudocapacitors under galvanostatic cycling," *Journal of Power Sources*, vol. 335, pp. 172–188, Dec. 2016.
- [70] D. Bernardi, E. Pawlikowski, and J. Newman, "A general energy balance for battery systems," *Journal of the Electrochemical Society*, vol. 132, no. 1, pp. 5–12, May. 1985.
- [71] G. Berckmans, J. Jaguemont, M. Soltani, A. Samba, M. Boninsegna, N. Omar, O. Hegazy, and J. V. Mierlo, "Lithium-ion capacitor - optimization of thermal management from cell to module level," in *Vehicle Power and Propulsion Conference*, Oct. 2016.
- [72] Y. Firouz, N. Omar, P. V. D. Bossche, and J. V. Mierlo, "Electro-thermal modeling of new prismatic lithium-ion capacitors," in *Vehicle Power and Propulsion Conference*, Oct. 2014, pp. 1–6.
- [73] D. L. Britton, T. B. Miller, and W. R. Bennett, "Thermal characterization study of lithium-ion cells," Aug. 2007.
- [74] P. Spanik, M. Frivaldsky, P. Drgona, J. Cuntala, and N. Glapa, "Design procedure of simple and accurate model of electric double layer capacitor (edlc) targeting fast verification purposes of heat transfer simulations," *Electrical Engineering*, vol. 96, no. 2, pp. 121–134, Jun. 2014.
- [75] B. W. Martin, "Heat transfer : J.p. holman," *International Journal of Heat & Fluid Flow*, vol. 3, no. 1, pp. 51–52, 1982.
- [76] V. Lystianingrum, B. Hredzak, V. G. Agelidis, and V. S. Djanali, "On estimating instantaneous temperature of a supercapacitor string using an observer based on experimentally validated lumped thermal model," *IEEE Transactions on Energy Conversion*, vol. 30, no. 4, pp. 1438–1448, Jun. 2015.
- [77] P. Guillemet, Y. Scudeller, and T. Brousse, "Multi-level reduced-order thermal modeling of electrochemical capacitors," *Journal of Power Sources*, vol. 157, no. 1, pp. 630–640, Jun. 2006.
- [78] W. Sarwar, M. Marinescu, N. Green, N. Taylor, and G. Offer, "Electrochemical double layer capacitor electro-thermal modelling," *Journal of Energy Storage*, vol. 5, pp. 10–24, Feb. 2016.
- [79] P. L. T. Brian, "A finite-difference method of high-order accuracy for the solution of three-dimensional transient heat conduction problems," *Aiche Journal*, vol. 7, no. 3, pp. 367–370, Sep. 1961.
- [80] K. Matsuda, J. Zheng, L. D. Madison, and P. Dallos, "High order adi method for solving unsteady convection–diffusion problems," *Journal of Computational Physics*, vol. 198, no. 1, pp. 1–9, Jul. 2004.
- [81] D. W. Peaceman and H. H. Rachford, "The numerical solution of parabolic and elliptic differential equations," *Journal of the Society for Industrial & Applied Mathematics*, vol. 3, no. 1, pp. 28–41, Mar. 1955.
- [82] COMSOL, *Simulate battery and fuel cell designs with the batteries & fuel cells module*, <https://uk.comsol.com/batteries-and-fuel-cells-module>, Accessed May 5, 2019, 2019.
- [83] ANSYS, *Ansys fluent*, <https://www.ansys.com/products/fluids/ansys-fluent>, Accessed May 5, 2019, 2019.
- [84] J. N. Reddy, *An introduction to the finite element method*, 2.2. McGraw-hill New York, 1993, vol. 2.
- [85] FRIVALDSKY, Michal, CUNTALA, Jozef, SPANIK, and Pavol, "Simple and accurate thermal simulation model of supercapacitor suitable for development of module solutions," *International Journal of Thermal Sciences*, vol. 84, no. 84, pp. 34–47, Oct. 2014.
- [86] KIZILEL, Riza, SABBAH, Rami, SELMAN, J. Robert, ALHALLAJ, and Said, "An alternative cooling system to enhance the safety of li-ion battery packs," *Journal of Power Sources*, vol. 194, no. 2, pp. 1105–1112, Dec. 2009.
- [87] A. A. Pesaran, A. Vlahinos, S. D. Burch, et al., *Thermal performance of EV and HEV battery modules and packs*. National Renewable Energy Laboratory, 1997.
- [88] A. A. Pesaran, "Battery thermal management in ev and hev: Issues and solutions," *Battery Man*, vol. 43, no. 5, pp. 34–49, Feb. 2001.
- [89] A. Pesaran, M. Keyser, and S. Burch, "An approach for designing thermal management systems for electric and hybrid vehicle battery packs," *Office of Scientific & Technical Information Technical Reports*, Jan. 1999.
- [90] A. Hijazi, P. Kreczanik, E. Bideaux, P. Venet, G. Clerc, and M. D. Loreto, "Thermal network model of supercapacitors stack," *IEEE Transactions on Industrial Electronics*, vol. 59, no. 2, pp. 979–987, Jun. 2011.
- [91] X. Zhang, W. Wang, H. He, L. Hua, and J. Heng, "Optimization of the air-cooled supercapacitor module compartment for an electric bus," *Applied Thermal Engineering*, vol. 112, pp. 1297–1304, Feb. 2017.
- [92] W. Tao, K. J. Tseng, J. Zhao, and Z. Wei, "Thermal investigation of lithium-ion battery module with different cell arrangement structures and forced air-cooling strategies," *Applied Energy*, vol. 134, no. C, pp. 229–238, Dec. 2014.
- [93] I. Voicu, H. Louahlia, H. Gualous, and R. Gallay, "Thermal management and forced air-cooling of supercapacitors stack," *Applied Thermal Engineering*, vol. 85, pp. 89–99, Jun. 2015.

- [94] P Guillemet, C Pascot, and Y Scudeller, "Electro-thermal analysis of electric double-layer-capacitors," in *International Workshop on Thermal Investigation of Ics & Systems*, Sep. 2008.
- [95] H. S. Al, J Prakash, and J. R. Selman, "Characterization of commercial li-ion batteries using electrochemical-calorimetric measurements," *Journal of Power Sources*, vol. 87, no. 1, pp. 186–194, Apr. 2000.
- [96] A. Eddahech, O. Briat, and J. M. Vinassa, "Thermal characterization of a high-power lithium-ion battery: Potentiometric and calorimetric measurement of entropy changes," *Energy*, vol. 61, no. 6, pp. 432–439, Nov. 2013.
- [97] A Virtanen, H Haapala, S HaNnikalnen, and T Muhonen, "Calorimetric efficiency measurements of supercapacitors and lithium-ion batteries," in *Applied Power Electronics Conference & Exposition*, Mar. 2011.
- [98] Y. Parvini, J. B. Siegel, A. G. Stefanopoulou, and A. Vahidi, "Supercapacitor electrical and thermal modeling, identification, and validation for a wide range of temperature and power applications," *IEEE Transactions on Industrial Electronics*, vol. 63, no. 3, pp. 1574–1585, Oct. 2015.
- [99] C.-J. Chiang, J.-L. Yang, and W.-C. Cheng, "Dynamic modeling of the electrical and thermal behavior of ultracapacitors," in *Control and Automation (ICCA), 2013 10th IEEE International Conference on*, IEEE, Jun. 2013, pp. 1839–1844.
- [100] H. Giess, "Investigation of thermal phenomena in vrla/agm stationary lead/acid batteries with a thermal video imaging system," *Journal of Power Sources*, vol. 67, no. 1-2, pp. 49–59, Jul.-Aug. 1997.
- [101] G. Sun, Y. Liu, R. Chai, F. Mei, and Y. Zhang, "Online model parameter identification for supercapacitor based on weighting bat algorithm," *AEU-International Journal of Electronics and Communications*, vol. 87, pp. 113–118, Apr. 2018.
- [102] Z. Yang, W. Li, Z. Yicheng, et al., "Structure and parameter identification of supercapacitors based on particle swarm optimization," *Proceedings of the CSEE*, vol. 32, no. 15, pp. 155–161, May. 2012.
- [103] A. Berrueta, I. S. Martin, A. Hernandez, A. Ursua, and P. Sanchis, "Electro-thermal modelling of a supercapacitor and experimental validation," *Journal of Power Sources*, vol. 259, no. 4, pp. 154–165, Aug. 2014.
- [104] X. Xu, B. G. Sammakia, D. Jung, and T. Eilertsen, "Multiphysics approach to modeling supercapacitors for improving performance," in *ASME 2011 Pacific Rim Technical Conference and Exhibition on Packaging and Integration of Electronic and Photonic Systems*, American Society of Mechanical Engineers, Jul. 2011, pp. 165–174.

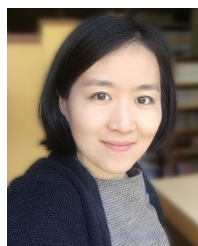

**Li Wei** (M'16) received the B.S. degree in electrical engineering and Ph.D. degree in control theory and control engineering from Tongji University, Shanghai, China, in 2004 and 2010, respectively.

She has been with Tongji University since 2000, where she is currently an associate professor in electrical engineering in the school of electronics and information engineering. From 2007 to 2008, she was a visiting Ph.D student in Ecole des Mines de Paris, Sophia Antipolis, France. She was a visiting scientist in RWTH Aachen University, Aachen, Germany from 2014 to 2015. In 2017, she was with Malardalens University, Vasteras, Sweden. From 2018 to 2019, she is a visiting scientist with Aalborg University, Aalborg, Denmark. She received Green Talents Award from the German Federal Ministry of Education and Research in 2014.

Her current research interests include the reliability of grid-scale supercapacitor energy storage system and optimized management methodology, high power density DC/DC converter for fuel cell vehicle.



**Ming Wu** received the B.S. degree in electrical engineering, in 2016, from Wuhan University of Technology, Hubei. Since autumn of 2017, he has been with the Laboratory of New Energy and Electrical Storage Equipment, Tongji University, working for M.S. degree. His research interests include the thermal optimization and thermal management strategy design of supercapacitors.



**Mengdi Yan** was born in Henan, China, in 1995. He received the B.S. degree in electrical engineering, in 2018, from Sichuan University, Chengdu, China. He is currently working toward the master's degree in Tongji University, Shanghai, China. His research interests include the management of the large scale supercapacitor storage system, the application of the supercapacitor in the power system.



**Shuai Liu** received the B.S. degree in electrical engineering and automation and Ph.D. degree in control theory and control engineering from Tongji University, Shanghai, China, in 2010 and 2015, respectively.

From 2015 to 2018, he was a load & control engineer in Shanghai Electric Wind Power Group, Shanghai, China. He is currently a post-doc with Department of Energy, Aalborg, Denmark. His current research interests include reliability of supercapacitors and capacitors, and multi-objective optimization of energy storage system.



**Qiang Cao** received the B.S. degree in electrical engineering and Ph.D. degree in refrigeration and cryogenics from Zhejiang University, Hangzhou, China, in 2006 and 2012, respectively.

He has been with Tongji University since 2014, where he is currently an assistant professor in the School of Mechanical Engineering. He was a visiting scientist in National Institute of Standards and Technology, USA, in 2012. From 2013 to 2014, he was with SINTEF, Norway. His research interests include Cryogenic refrigeration technology, heat transfer and cooling technology.



**Huai Wang** (M'12, SM'17) received the B.E. degree in electrical engineering, from Huazhong University of Science and Technology, Wuhan, China, in 2007 and the Ph.D. degree in power electronics, from the City University of Hong Kong, Hong Kong, in 2012. He is currently an Associate Professor at the Center of Reliable Power Electronics (CORPE), and Vice Leader of Efficient and Reliable Power Electronics Research Program at Aalborg University, Aalborg, Denmark, and. He was a Visiting Scientist with the ETH Zurich, Switzerland, from Aug. to Sep. 2014, and with the Massachusetts Institute of Technology (MIT), USA, from Sep. to Nov. 2013. He was with the ABB Corporate Research Center, Switzerland, in 2009. His research addresses the fundamental challenges in modelling and validation of power electronic component failure mechanisms, and application issues in system-level predictability, condition monitoring, circuit architecture, and robustness design.

Dr. Wang received the Richard M. Bass Outstanding Young Power Electronics Engineer Award from the IEEE Power Electronics Society in 2016, and the Green Talents Award from the German Federal Ministry of Education and Research in 2014. He is currently the Chair of IEEE PELS/IAS/IE Chapter in Denmark. He serves as an Associate Editor of IET Electronics Letters, IEEE JOURNAL OF EMERGING AND SELECTED TOPICS IN POWER ELECTRONICS, and IEEE TRANSACTIONS ON POWER ELECTRONICS.