



Aalborg Universitet

AALBORG UNIVERSITY
DENMARK

Impact of Background Harmonic on Filter Capacitor Reliability in Wind Turbine

Zhou, Dao; Song, Yipeng; Blaabjerg, Frede

Published in:

Proceedings of 2019 IEEE Applied Power Electronics Conference and Exposition (APEC 2019)

DOI (link to publication from Publisher):

[10.1109/APEC.2019.8721996](https://doi.org/10.1109/APEC.2019.8721996)

Publication date:

2019

Document Version

Accepted author manuscript, peer reviewed version

[Link to publication from Aalborg University](#)

Citation for published version (APA):

Zhou, D., Song, Y., & Blaabjerg, F. (2019). Impact of Background Harmonic on Filter Capacitor Reliability in Wind Turbine. In *Proceedings of 2019 IEEE Applied Power Electronics Conference and Exposition (APEC 2019)* (pp. 1957-1962). [8721996] IEEE Press. IEEE Applied Power Electronics Conference and Exposition (APEC) <https://doi.org/10.1109/APEC.2019.8721996>

General rights

Copyright and moral rights for the publications made accessible in the public portal are retained by the authors and/or other copyright owners and it is a condition of accessing publications that users recognise and abide by the legal requirements associated with these rights.

- ? Users may download and print one copy of any publication from the public portal for the purpose of private study or research.
- ? You may not further distribute the material or use it for any profit-making activity or commercial gain
- ? You may freely distribute the URL identifying the publication in the public portal ?

Take down policy

If you believe that this document breaches copyright please contact us at vbn@aub.aau.dk providing details, and we will remove access to the work immediately and investigate your claim.

Impact of Background Harmonic on Filter Capacitor Reliability in Wind Turbine

Dao Zhou, Yipeng Song, and Frede Blaabjerg

Department of Energy Technology
Aalborg University, Aalborg, Denmark
zda@et.aau.dk; yis@et.aau.dk; fbl@et.aau.dk

Abstract - Pulse width modulation converters are now used in many grid-connected application. A filter is normally inserted between the converter and the power grid to reduce the switching harmonics. Since the wind power is normally linked to the power grid through a long transmission line, the grid voltage becomes distorted and contains lower-order harmonics. By using the separated models of fundamental component, low-order, and high-order harmonics, the electrical stresses of the filter capacitor can be comprehensively evaluated. The performance of the Proportional-Integral (PI) and the Proportional-Integral-Resonant (PIR) current regulator have been analyzed with different grid distortion levels, and loading conditions. A case study of 2 MW wind power converter shows that, by using the conventional PI current control, the capacitor lifetime is considerably reduced if the background harmonic exists all year around. Nevertheless, the PIR current regulator can eliminate the additional electrical stresses of the filter capacitor caused by the background harmonic and is thereby a better solution.

I. INTRODUCTION

Wind generation systems are being increasingly installed in remote area, such as offshore wind farms. In order to inject the generated power to the grid, the power transfer typically requires long transmission lines, which might make these connections weak due to the limited capacities [1], [2]. The presence of voltage disturbances (e.g. voltage sag, voltage imbalance, and voltage distortion) are more severe in these weak transmission lines. Moreover, the grid codes require that wind turbines are able to withstand certain voltage disturbances without tripping.

Pulse Width Modulated (PWM) converters are now used in many grid-connected applications, including the renewable energy systems (e.g. photovoltaic, wind, fuel cell, etc.) and adjustable-speed drivers when regenerative braking is required [3]. A filter is often inserted between the grid-connected converter and the power grid in order to attenuate the switching harmonic to be within an acceptable level. Typically, the series inductor is used as the filter interface due to its simple structure. The alternative LCL filter offers the potential for improved harmonic performance at lower switching frequencies. However, due to the resonance hazard

of the LCL filter, damping solutions are needed to maintain the system stability [4].

The performance of power capacitor is complicated and highly affected by its operation conditions, such as the voltage, current, frequency, and temperature. Many researchers have investigated the degradation of the electrolytic capacitors [5]-[7]. However, few studies investigate the mission profile impact on the degradation of the film capacitor, which is widely used in the LCL filter. Moreover, the power grid voltage is normally not purely sinusoidal due to the large amount of diode rectifiers, and the harmonic influence on the reliable operation of the filter capacitor is of interest and importance.

This paper addresses the background harmonic impact on the filter capacitor used in the wind power application. Section II briefly describes function of LCL filter capacitor. Electrical stresses of the filter capacitor is comprehensively analyzed in Section III, which considers the various types of current regulators, background distortion level, and the loading conditions. Section IV addresses a mission profile based lifetime estimation of the filter capacitor, and compares its annual damage by considering various background harmonic profiles. Finally, concluding remarks are drawn in last section.

II. FUNCTION OF FILTER CAPACITOR

The typical configuration of the DFIG is graphically shown in Fig. 1, where the rotor-side of the generator is linked to a partial-scale back-to-back power converter through slip rings. The rotor-side converter aims to regulate the active and reactive power of the generator stator-side, while the grid-side converter serves to maintain the constant DC-link voltage and to provide part of the reactive power required by the grid codes. Due to lots of switching harmonic voltage introduced by the PWM inverter, a filter is normally employed in between to mitigate the corresponding harmonic current flowing into the grid [8].

The design procedure of the LCL filter is well described in [9], where the converter-side inductor is selected according to the switching ripple requirement, while the grid-side inductor is chosen based on the harmonic specification from the IEEE standard. For the filter capacitor, it is generally designed viewed from additional introduced reactive power. As higher capacitance causes an increased current stress and loss

dissipation, 5-15% of the absorbed reactive power at the rated operation condition is a rule-of-thumb [9]. Due to the high withstand voltage and non-polarity, the metallized film capacitors are normally applied as the filter capacitor. Moreover, the dielectric material with the polypropylene (PP) is preferred compared to the polyethylene terephthalate (PET) owing to the much lower loss factor. One of the main failure modes is often caused by high current stress and internal temperature, which leads to a reduction of the breakdown voltage and even melting of the capacitor.

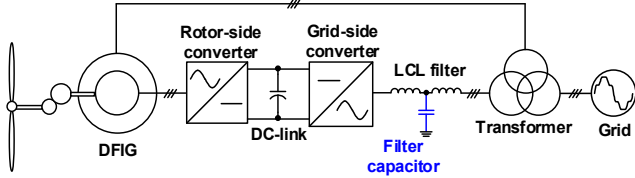

Fig. 1. Doubly-fed induction generator based wind turbine system with an LCL filter.

III. CONTROL IMPACT ON ELECTRICAL STRESSES OF FILTER CAPACITOR

Due to the high penetration of the diode rectifier loads, the grid voltage cannot be purely sinusoidal, and the background harmonics (5th, 7th, 11th, and 13th, etc.) normally exist. As the existence of the background harmonic deteriorates the quality of the grid-feeding current, the performance with various current controllers will be investigated and compared in this

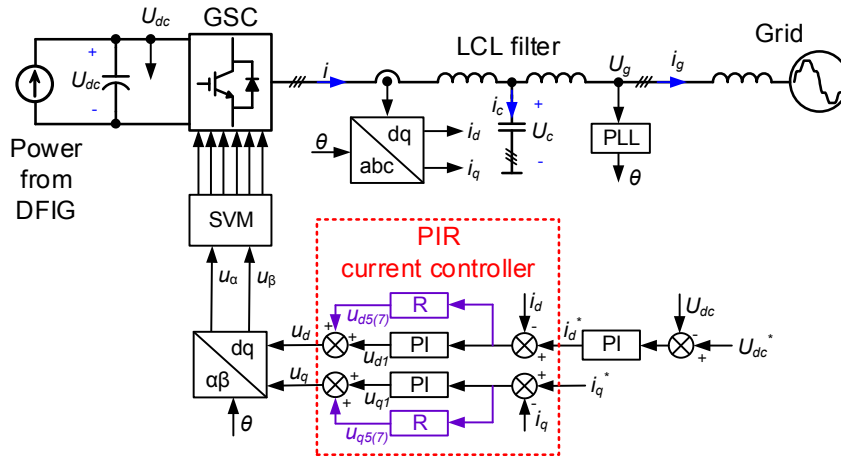

Fig. 2. Control structure of the grid-side converter under background harmonic.

B. Analysis approach for background harmonic

With the parameters of the grid-side converter and its current controller listed in Table I, the amplitude and frequency characteristic can be seen in Fig. 3 for the LCL filter plant and current controller. Since the resonant controller is able to overcome different orders of harmonics by the adjusting the resonant frequencies, it is assumed that 5th and 7th order harmonics are the key components of the distorted grid. Due to the same value of the grid inductor and the converter inductor, the converter and grid voltage has an identical impact on the filter capacitor voltage and current.

The individual model of each harmonic component can be established in order to evaluate the control scheme, distortion level, and loading condition impact on the electrical stresses of the filter capacitor.

A. Control scheme under grid distortion

As the behavior of the filter capacitor is purely dominated by the grid-side converter, the power from the DFIG can be simplified as the current source like shown in Fig. 2. Dual-loop controller design is normally applied – the outer loop deals with the constant DC-link voltage, while the inner loop takes care of the converter-side current quality. In addition, the grid voltage is measured to obtain the phase angle, which is fundamental to realize the vector control in the synchronous rotating dq-axis.

In the case of the normal grid, as the sinusoidal reference current becomes DC value under the dq-axis, the PI controller is used for the current control. However, if the background harmonic exists, the current flowing into the grid may become distorted due to the limited bandwidth of the PI controller. With the help of dq transformations under various harmonic orders as well as the corresponding Low-Pass Filters (LPF), the harmonic current reference can be set to zero under each harmonic order by using multiple PI controllers. Alternatively, a resonant controller can be employed to compensate the harmonic components of the grid voltage [10], which is more efficient and convenient to be implemented.

The transfer functions from the converter/grid voltage to the capacitor voltage and current are as shown in Fig. 3(a), which indicates that both 5th and 7th orders of capacitor current and voltage are considerably suppressed from the converter/grid voltage. Nevertheless, as the fundamental component of the capacitor current is 10% of the rated current, the background voltage harmonics may still have significant influence on the behavior of the capacitor current. As the converter voltage at the 5th and 7th order cannot be fully controlled by using PI controller, the PIR controller is preferred in the case of the grid distortions.

Table I

PARAMETERS OF GRID-SIDE CONVERTER AND CURRENT CONTROLLER

Parameters of power circuit	
Rated power	400 kW
Rated amplitude of grid voltage (base voltage)	563 V
Rated amplitude of grid current (base current)	395 A
Grid equivalent inductor	4 μ H
Grid-side inductor	125 μ H
Converter-side inductor	125 μ H
Filter capacitor	300 μ F
DC-link voltage	1050 V
Parameters of current controller	
Switching frequency	2 kHz
Proportional coefficient	0.3
Integral coefficient	15
Resonant coefficient	5

The performance of the PI and PIR controllers is investigated and compared in Fig. 3(b). It can be seen that the PIR controller has an additional infinite gain at 300 Hz compared to the PI controller at 0 Hz, which implies that the fundamental, 5th, and 7th order harmonics of the converter voltage can be fully regulated by using the PIR controller.

Due to the existence of the low-order background harmonics, together with the high-order harmonic caused by the modulation, the individual model of each harmonic component can thereby be established as shown in Fig. 4. The fundamental component of the converter current reference is determined by the transferred power from the DFIG, while its current reference at 5th and 7th orders is controlled to be zero. Due to the fact that the impedance of filter capacitor at fundamental frequency is typically much higher than the grid inductor, the fundamental component of the converter current flows hardly through the capacitor branch. Nevertheless, it is worthwhile to mention that around 0.1 pu fundamental current still exists, because the voltage across the filter capacitor is

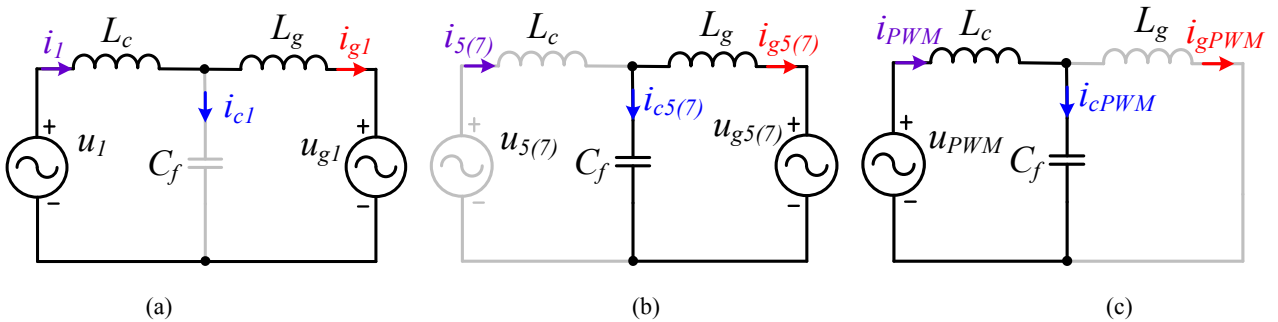

Fig. 4. Harmonic analysis of the filter capacitor current. (a) Fundamental component. (b) Low-order harmonics due to background harmonics. (c) High-order harmonics due to PWM modulation.

C. Simulation results

In order to analyze the background harmonic impact on the electrical stresses of the filter capacitor, the capacitor current

and voltage are simulated with PI and PIR current controllers. Fig. 5 shows the simulated results under the rated wind speed, where both the normal grid and its distortion (10% of 5th and

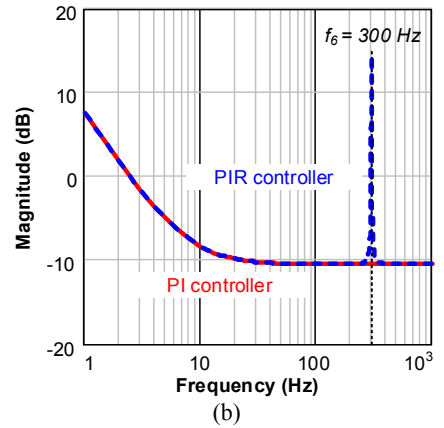
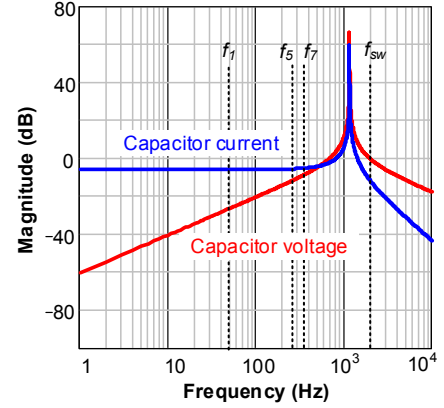

Fig. 3. Amplitude and frequency characteristic curve. (a) LCL filter characteristic from converter/grid voltage to filter capacitor voltage and current. (b) PI and PIR controller.

and voltage are simulated with PI and PIR current controllers. Fig. 5 shows the simulated results under the rated wind speed, where both the normal grid and its distortion (10% of 5th and

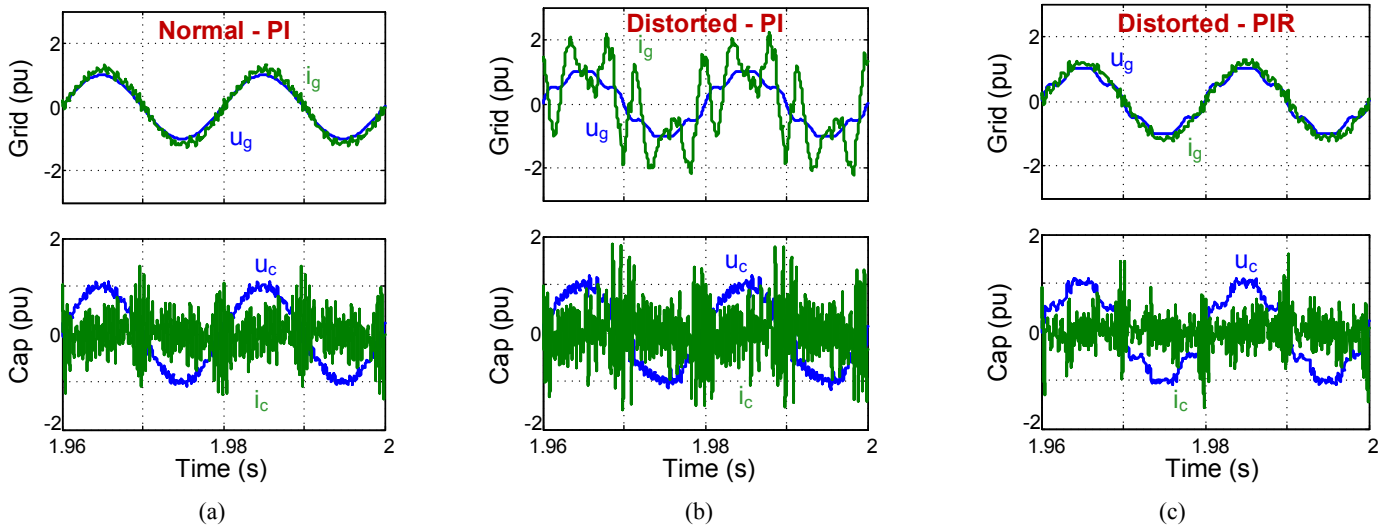

Fig. 5. Simulation results of power grid and filter capacitor at rated wind speed. (a) Normal grid with PI controller. (b) Distorted grid with PI controller. (c) Distorted grid with PIR controller.

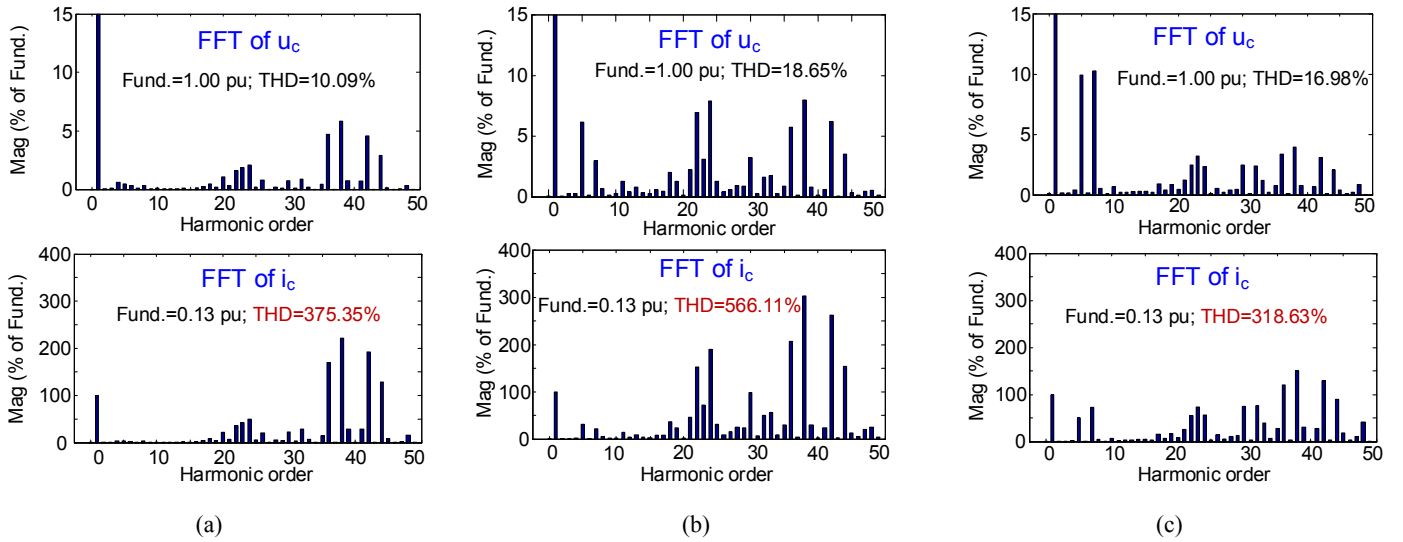

Fig. 6. FFT analysis of the filter capacitor voltage and current. (a) Normal grid with PI controller. (b) Distorted grid with PI controller. (c) Distorted grid with PIR controller.

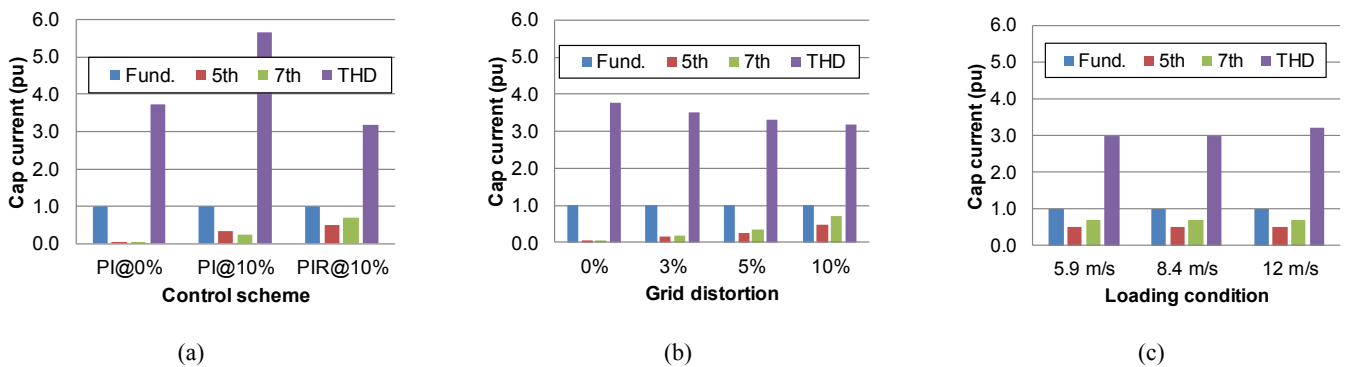

Fig. 7. Impact from various factors on fundamental, low-order harmonics, and THD of the capacitor current. (a) Control scheme. (b) Level of grid distortion. (c) Loading condition.

7th background harmonics) are taken into account. In the case of the normal grid, by using the PI controller, the

sinusoidal grid current is in phase with the grid voltage as shown in Fig. 5(a). In the case that the grid becomes distorted

as shown in Fig. 5(b) and (c), the PI controller cannot handle the case with the background harmonics, and the grid current is significantly distorted with a large amount of the low-order harmonics. By using the PIR controller, the sinusoidal grid current appears again regardless of the grid distortion.

In respect to the electrical stresses of the filter capacitor, its current and voltage under the time-domain look almost the same regardless of the grid conditions or control schemes. Consequently, the FFT analysis of the capacitor voltage and current is shown in Fig. 6. In respect to the capacitor voltage, although the grid distortion brings the 5th and 7th order harmonics, the fundamental component of the capacitor voltage is still most dominant. However, in the case of the grid distortion, the THD of the capacitor current becomes the worst with the traditional PI controller, while by using the PIR controller, the capacitor current THD is at the same level as with the normal grid condition.

Fig. 7(a) summarizes the control scheme impact on the harmonic distribution of the capacitor current. It is evident that, under the grid distortion, the PIR controller is preferred from the minimum current of the filter capacitor. At various levels of grid distortion, the capacitor voltage and current are again simulated, and its impact is presented in Fig. 7(b). Moreover, the loading conditions at the sub-synchronous operation of 5.9

m/s, synchronous operation of 8.4 m/s, and super-synchronous operation of 12 m/s are investigated as shown in Fig. 7(c). It can be seen that the THD remains almost unchanged under various distortion levels and different loading conditions.

IV. MISSION PROFILE BASED LIFETIME AND RELIABILITY ANALYSIS

According to the mission profile of the wind turbine system, a general procedure to calculate the lifetime of the filter capacitor is illustrated in Fig. 8. On the basis of the wind speed, the produced power can be predicted by the MPPT curve. With the information of the background harmonics, the current and voltage stresses of the filter capacitor are analyzed and evaluated with the generator and converter models. With the help of the FFT analysis, their dominant harmonic spectrum can be obtained, which further serves to the power loss calculation together with the capacitor ESR. Moreover, the core temperature is jointly decided by the core-ambient thermal resistance and the ambient temperature profile. Together with the applied voltage across the filter capacitor, its lifetime can thereby be estimated based on the lifetime model [11]. It is worthwhile to mention that the hours to failure is defined as the B_{10} lifetime – only 10% of the samples fails when the operational hours reach this condition.

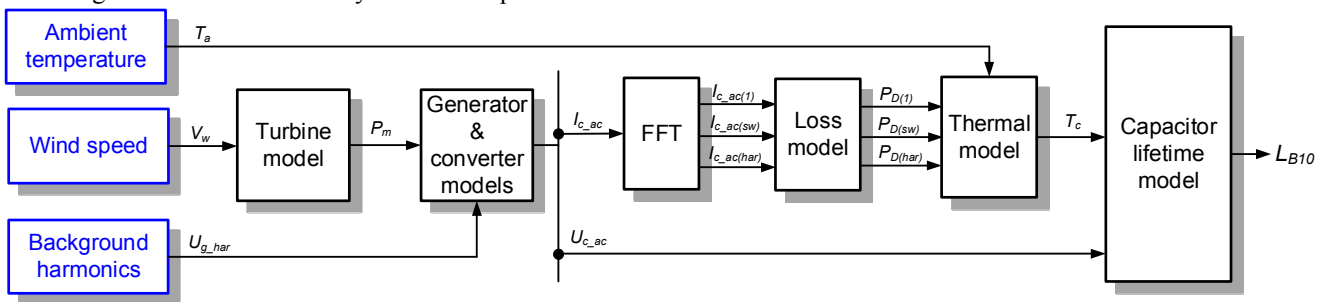

Fig. 8. Mission profile based flow-chart to calculate B_{10} lifetime of filter capacitor.

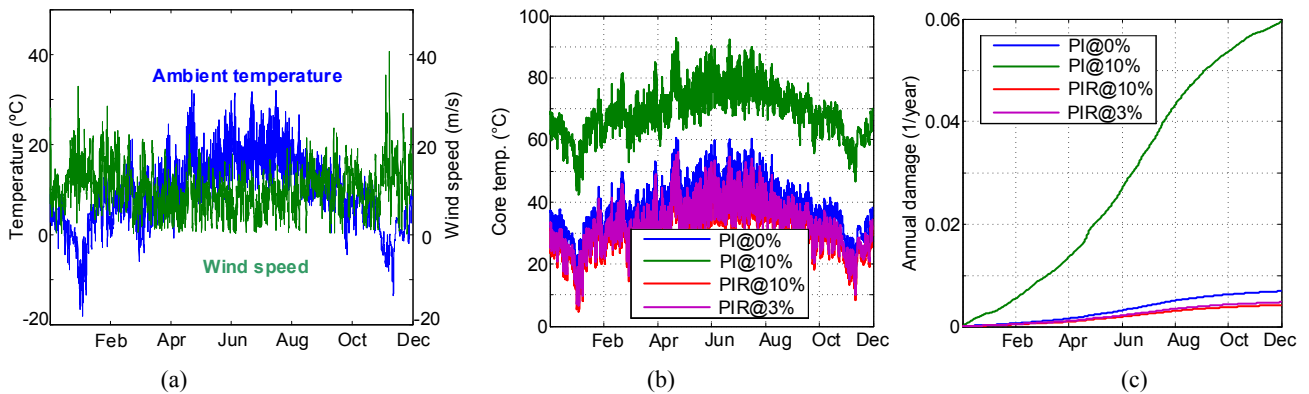

Fig. 9. Annual profile comparison with different types of current controller under the normal and distorted grid. (a) Ambient temperature and wind speed. (b) Core temperature of filter capacitor. (c) Accumulated annual damage.

With the annual wind speed (Class I) and ambient temperature with a sample rate of 1 hour as shown in Fig. 9(a), the core temperature profile of the filter capacitor is presented in Fig. 9(b). As the sample time interval is much higher than

the capacitor thermal time constant (typically several minutes), it can roughly be assumed that the core temperature of the capacitor reaches the steady-state and stays constant within every sample period. The damage can thereby be calculated by

using the sample period over its corresponding hours to failure [12], which is accumulated from a sample period to the whole year. As a result, the annual damage of the capacitor can be deduced like shown in Fig. 9(c), where the lifecycle of the capacitor runs out when the accumulated damage reaches 1. In order to analyze the background harmonic impact on the capacitor lifetime, the same PI current controller is applied with the normal grid and grid distortion of 10%. It can be seen that the annual damage is almost 10 times higher in the case of the grid distortion. Nevertheless, if the PIR current controller is introduced under background harmonics, the annual damage keeps almost the same with the normal grid. In addition, various distortion levels are compared, and it is found that the same annual damage appears regardless of the distortion levels, which agrees well with the same harmonic distribution of the capacitor current as shown in Fig. 7(b).

V. CONCLUSION

Aiming at the reliable operation of the LCL filter used in the wind turbine system, this paper studies the background harmonic impact on the lifetime expectation of the ac filter capacitor. According to the performance of the PI and the PIR current regulators, the electrical stresses of the filter capacitor can be evaluated under the distorted power grid. Together with the individual model of each harmonic component, the capacitor current can be investigated by separation into the fundamental component, low-order harmonics (due to background harmonics), and high-order harmonics (due to PWM modulation). A large number of the simulation results show that the control scheme may have significant impact on the capacitor current THD, while the distortion level and loading condition have much less impact on the current performance of the filter capacitor. Considering the annual mission profile and corresponding electro-thermal profile, the lifetime of the filter capacitor can be predicted based on its lifetime model. In the case that the background harmonic exists all year around, it can be found that capacitor lifecycle is almost 10 times less with the PI controller compared to the normal grid condition. Nevertheless, by using the PIR current regulator, the impact from the background harmonic on the electrical stresses of the filter capacitor can be almost eliminated, and thereby keep a similar lifetime expectation as the normal grid.

References

- [1] F. Blaabjerg, and K. Ma, "Wind energy systems," *Proceedings of the IEEE*, vol. 105, no. 11, pp. 2116-2131, Nov. 2017.
- [2] C. Liu, F. Blaabjerg, W. Chen, and D. Xu, "Stator current harmonic control with resonant controller for doubly fed induction generator," *IEEE Trans. on Power Electronics*, vol. 27, no. 7, pp. 3207-3220, Jul. 2012.
- [3] E. Twining, and D. G. Holmes, "Grid current regulation of a three-phase voltage source inverter with an LCL input filter," *IEEE Trans. on Power Electronics*, vol. 18, no. 3, pp. 888-895, May 2003.
- [4] F. Blaabjerg, Y. Yang, D. Yang, and X. Wang, "Distributed power-generation systems and protection," *Proceedings of the IEEE*, vol. 105, no. 7, pp. 1311-1331, July 2017.
- [5] K. Abdennadher, P. Venet, G. Rojat, J. M. Retif, and C. Rosset, "A realtime predictive-maintenance system of aluminum electrolytic capacitors used in uninterrupted power supplies," *IEEE Trans. on Industry Applications*, vol. 46, no. 4, pp. 1644-1652, Jul. 2010.
- [6] A. Lahyani, P. Venet, G. Grellet, and P. J. Viverge, "Failure prediction of electrolytic capacitors during operation of a switch-mode power supply," *IEEE Trans. on Power Electronics*, vol. 13, no. 6, pp. 1199-1207, Nov. 1998.
- [7] M. L. Gasperi, "Life prediction modeling of bus capacitors in ac variable frequency drives," *IEEE Trans. on Industry Applications*, vol. 41, no. 6, pp. 1430-1435, Nov. 2005.
- [8] L. Malesani, L. Rossetto, P. Tenti, and P. Tomasin, "AC/DC/AC PWM converter with reduced energy storage in the DC link," *IEEE Trans. on Industry Applications*, vol. 31, no. 2, pp. 287-292, Mar. 1995.
- [9] M. Liserre, F. Blaabjerg, and S. Hansen, "Design and control of an LCL-filter-based three-phase active rectifier," *IEEE Trans. on Industry Applications*, vol. 41, no. 5, pp. 1281-1291, Sep. 2005.
- [10] M. Liserre, R. Teodorescu, and F. Blaabjerg, "Multiple harmonics control for three-phase grid converter systems with the use of PI-RES current controller in a rotating frame," *IEEE Trans. on Power Electronics*, vol. 21, no. 3, pp. 836-841, May 2006.
- [11] "Aluminum Can Power Film Capacitors for PFC and AC Filter," KEMET datasheet, 2007
- [12] D. Zhou, Y. Song, Y. Liu, and F. Blaabjerg, "Mission profile based reliability evaluation of capacitor banks in wind power converters," *IEEE Trans. on Power Electronics*, IEEE early access.