



Aalborg Universitet

AALBORG UNIVERSITY
DENMARK

Smart Micro-grid System with Wind/PV/Battery

Liu, Wenzhou; Li, Ning; Jiang, Zhihong; Chen, Zhe; Wang, Siyuan; Han, Jian; Zhang, Xiao; Liu, Chang

Published in:
Energy Procedia

DOI (link to publication from Publisher):
[10.1016/j.egypro.2018.09.171](https://doi.org/10.1016/j.egypro.2018.09.171)

Creative Commons License
CC BY-NC-ND 4.0

Publication date:
2018

Document Version
Publisher's PDF, also known as Version of record

[Link to publication from Aalborg University](#)

Citation for published version (APA):
Liu, W., Li, N., Jiang, Z., Chen, Z., Wang, S., Han, J., Zhang, X., & Liu, C. (2018). Smart Micro-grid System with Wind/PV/Battery. *Energy Procedia*, 152, 1212-1217. <https://doi.org/10.1016/j.egypro.2018.09.171>

General rights

Copyright and moral rights for the publications made accessible in the public portal are retained by the authors and/or other copyright owners and it is a condition of accessing publications that users recognise and abide by the legal requirements associated with these rights.

- ? Users may download and print one copy of any publication from the public portal for the purpose of private study or research.
- ? You may not further distribute the material or use it for any profit-making activity or commercial gain
- ? You may freely distribute the URL identifying the publication in the public portal ?

Take down policy

If you believe that this document breaches copyright please contact us at vbn@aub.aau.dk providing details, and we will remove access to the work immediately and investigate your claim.



CUE2018-Applied Energy Symposium and Forum 2018: Low carbon cities and urban energy systems, 5–7 June 2018, Shanghai, China

Smart Micro-grid System with Wind/PV/Battery

Wenzhou Liu^a, Ning Li^b, Zhihong Jiang^a, Zhe Chen^c, Siyuan Wang^b, Jian Han^b, Xiao Zhang^a, Chang Liu^d

^a School of Electrical Engineering and Information Technology, Changchun Institute of Technology, Changchun 130012, China

^b School of Electrical and Electronic Engineering, Changchun University of Technology, Changchun 130012, China

^c Department of Energy Technology, Aalborg University, Aalborg, Denmark

^d Department of Electrical Engineering, Tsinghua University

Abstract

A 6kW smart micro-grid system with wind /PV/battery has been designed, the control strategy of combining master-slave control and hierarchical control has been adopted. An energy management system based on battery *SOC* has been proposed for the smart micro-grid system so that the management functions, such as measurement and testing, protection, operation mode selection, power supply control and load management of the smart micro-grid, can be realized. The performance of the micro grid and the control strategy presented in the paper has been demonstrated and verified in various operation modes, including direct supply of wind and solar energy, energy feedback to grid, power supply from battery, power supply by external power grid and load limitation modes.

Copyright © 2018 Elsevier Ltd. All rights reserved.

Selection and peer-review under responsibility of the scientific committee of the CUE2018-Applied Energy Symposium and Forum 2018: Low carbon cities and urban energy systems.

Keywords: Smart micro-grid, energy management, battery, *SOC* ;

0. Preface

Distributed generation is featured with lower cost, higher energy utilization efficiency and less pollution. However, viewed from high voltage power grid, it is uncontrollable. A smart micro grid, consisting of distributed generators, load, energy storage and protection control devices, is an independently controllable system covering complete power generation, transmission, distribution and energy utilization systems. Which can effectively solve

the contradiction between large power grid and distributed generation, and promote the development of distributed generation technology. Distributed generators are mostly integrated with power electronic devices into smart microgrids, in order to maintain the stable operation of the smart microgrid, the effective control of the distributed generators and the corresponding power electronic interfaces is needed. Literature [1] has carried out a thorough study and proposed a scheme to control the frequency and voltage of the power generation unit through the power electronic interfaces.

Smart microgrid is normally based on new energy generation technology and power electronics technology. It promotes the grid acceptance of various distributed generators, realizes the complementary advantages of different generation units, improves the utilization efficiency [2], and reduces the potential negative impact of a single distributed power supply on the power grid.

Smart microgrid through effective energy management strategy, not only supports the safe operation of power distribution grid, but also realizes the flexible control of the distributed generators, so that the renewable and clean energy sources can be maximally utilized, therefore. smart microgrid is an important part of the smart grid [3][4].

Stabilized operation control and optimized energy management are currently hot research topics for intelligent micro-grid [5][6]. The control strategy of microgrid is studied in literature [5], and the hierarchical control strategy is introduced in detail. Literature [6] proposes an energy management algorithm for coordinating distributed generators in microgrids. In this paper, we built an experimental smart microgrid platform with wind /PV/battery, It adopts master slave control and hierarchical control strategy. The energy management system is designed based on battery *SOC* level. It aims to enhance the operation mode of the smart microgrid system, regulate the state of energy storage, optimize the energy balance of the distribution grid, distributed generators and loads, and ensure the safety, stability and high efficiency of the system.

1. A Smart micro-grid system for wind /PV/battery

The developed 6kW smart micro-grid system with wind /PV/battery consists of a 3kW wind power generation unit, a 3kW photovoltaic generation unit, battery energy storage unit, load and the control system. The smart micro-grid system is connected via an AC bus with distributed power supply, wind and solar power generators. It offers wider range of connections, higher efficiency of energy transmission, easier expansion of independent power generation units and flexible selection of operation modes.

The developed control system adopts the structure of combining master/slave control and hierarchical control, as a bottom layer control and an upper layer control, as shown in Figure 1. The bottom control adopts master-slave control, and battery energy storage is the main control unit to stabilize the grid. In the situation of grid connection, PQ control is adopted, and the system voltage and frequency are supported by the grid. For off grid operation, VF control is adopted so that battery will support system voltage and frequency via DC-AC converter. PQ control is adopted for the inverters of wind power generation and photovoltaic power generation, thereby generating as much power as possible [7]. Individual units at the bottom layer will not only execute their own automated control, but also follow the commands from the upper layer. The upper layer is an energy management layer executing control based on battery *SOC*.

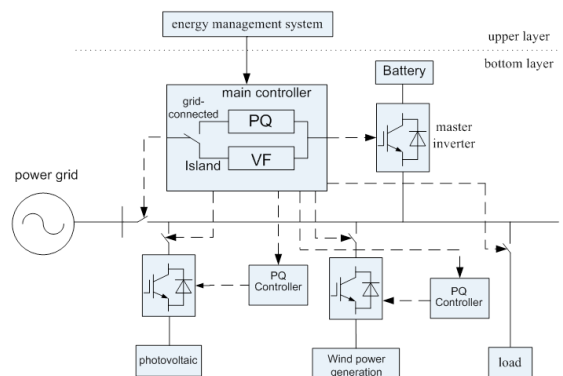

Fig. 1. Structure of smart micro-grid control system

2. Energy management system of the smart micro-grid

In this paper, the energy management system is design based on the battery *SOC* value. *SOC* is an important index to measure charge and discharge capability with a scale between [0,1], and can be expressed as (1)

$$SOC = \frac{Q - \int_0^t i(t) dt}{Q_{bat}} \tag{1}$$

Where Q is initial quantity of electricity, Q_{bat} is total battery capacity, i is current of charging and discharging. In the microgrid system, the upper and lower limits of the battery SOC need to be set, so that the battery can charge or discharge in the specified working range. It is expressed as:

$$SOC_{min} \leq SOC \leq SOC_{max} \tag{2}$$

Where SOC_{min} is lower limit value, SOC_{max} is upper limit value.

The SOC of the battery will also affect its maximum charge and discharge power, the expression is:

$$0 \leq P_{ch}^{max}(t) \leq \min \left\{ [SOC_{max} - SOC(t)] \frac{C_{bat}}{\Delta t}, I_{ch}^{max} \times V_{bat}(t) \right\} \quad 0 \leq P_{dh}^{max}(t) \leq \min \left\{ [SOC(t) - SOC_{min}] \frac{C_{bat}}{\Delta t}, I_{dh}^{max} \times V_{bat}(t) \right\} \tag{3}$$

Where P_{ch}^{max} is maximum charging power, P_{dh}^{max} is maximum discharging power, C_{bat} is ampere-hour capacity, I_{ch}^{max} is maximum charging current, I_{dh}^{max} is maximum discharging current, V_{bat} is battery voltage.

The energy management system can determine an operation mode among five operation modes: (1) Direct supply from wind and solar generators: if the power generated from photovoltaic and wind generator is sufficient, the loads are mainly supplied by photovoltaic and wind power generation units. Energy storage unit only covers the power difference by charging or discharging. (2) Mode of energy feedback: if the generation of photovoltaic and wind power is sufficient and the battery is so charged that the SOC value is enough high, the intelligent micro-grid will send the surplus energy back to the external power grid. (3) Mode that the power is supplied by battery: the power from photovoltaic and wind power is insufficient to supply the loads, the external power grid will supply the loads and charge the battery. (4) Mode that the power is supplied by external power: photovoltaic and wind power generation is insufficient and cannot meet the load needs, and the external power grid supplies load and charges the battery. (5) Load power limitation mode: if the external power supply is not available due to a failure and the generation of photovoltaic and wind power is insufficient, and the battery SOC is at the allowed lowest level, some loads may have to be temporarily cut off to protect the battery.

Main function modules of the energy management system include communication module, control module and display module are shown in figure 2, the operation curve, state parameters, control configuration and control log can also be seen. The control flow of the energy management system[8] is shown in figure 3.

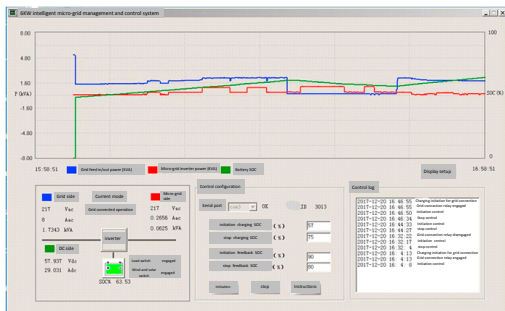

Fig. 2. Software screen for energy management system

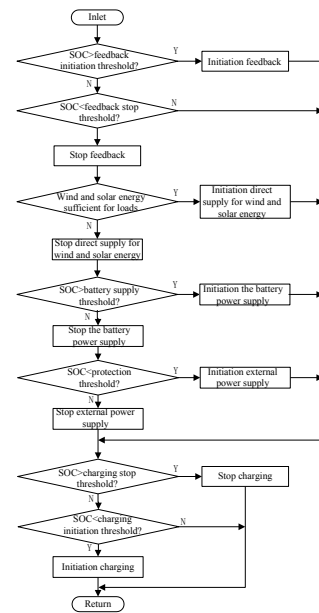

Fig. 3. Flow chart for energy management system

3. Experimental study of the proposed smart micro-grid system

The smart micro-grid system has been tested in various operation modes in the experimental studies, the control ability of mode switching under the energy management system has been demonstrated and the power quality of the smart micro-grid system under all operating modes are evaluated. Firstly, SOC parameters are set as follows:

- $SOC \leq 0.2$ Start charging; $SOC \leq 0.7$ Stop feedback; $SOC \leq 0.1$ Load limiting;
- $SOC > 0.5$ Stop charging; $SOC > 0.9$ Start feedback; $SOC > 0.15$ Load connection

Then experimental work on the smart micro-grid system in five different operation modes has been performed as below:

(1) Direct supply by wind and solar energy power

In this case, the system operates as an island. VF control strategy is adopted by the master controller. The battery and its power electronic converter will establish the system voltage and the power fluctuations of the system shall be regulated by charging or discharging the battery. During PV inverter connection, the changes of the master inverter AC bus voltage and AC output current waveforms are shown in figure 4. Yellow curve is voltage waveform and blue curve is current waveform. The amplitude of voltage basically is maintained by master inverter as unchanged. The current slowly reduces and then changes the direction, that is, the direction of power flow is reversed. The power supplied to the load is changed from the battery to the distributed power supply and the battery is charged by the power supply so that the current direction of the battery is reversed.

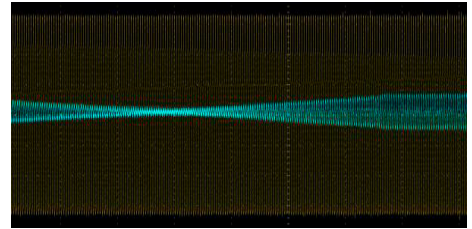

Fig.4. Waveforms for voltage and current for AC bus

The voltage waveform, harmonic content in the voltage and frequency fluctuation of the AC bus in the micro-grid are shown in figure 5, for the system operation stabilized in the mode of direct supply by wind and solar power generator. The waveform of bus voltage is standard sinusoidal wave and the third-order harmonic is the highest harmonic component, which is only 0.535%. Compared with fundamental wave, such harmonic content is very low. The frequency varies slightly around 50Hz, which is compliant with 50Hz±0.2Hz.

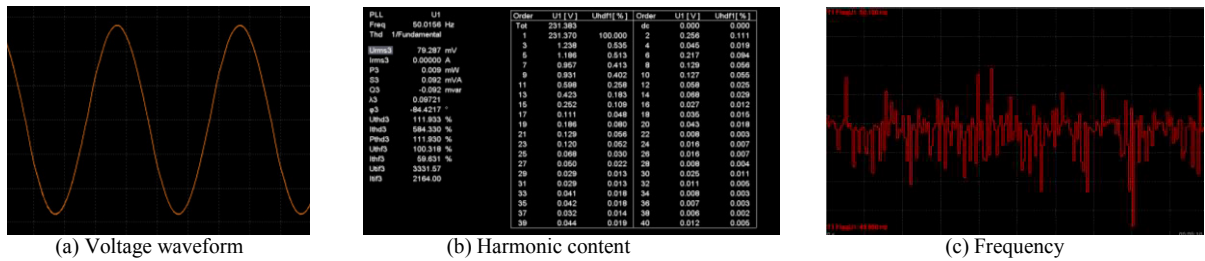

Fig.5. Electrical energy quality under direct supply by wind and solar power

(2) Energy feedback mode

When wind and solar generate sufficient power and the SOC of battery is higher than 0.9, the energy management system will initiate energy feedback mode. In such a case, the smart micro-grid is switched into grid-connected operation, the system frequency and voltage will be held by the power grid. The master inverter of the system and wind and solar inverters are operated in PQ control. The wind inverter and photovoltaic inverter are tracked and regulated for maximum power capture so that the wind and solar resources can be fully utilized.

The variations of AC bus voltage, AC input current on grid side, and internal AC output current during grid connection are shown in figure 6. The AC input current on grid side ranges from zero to a certain level. The smart micro-grid will transfer power to the grid. There is small fluctuation during grid-connection transient when the grid into the stable operation, the current basically remains unchanged before and after grid connection.

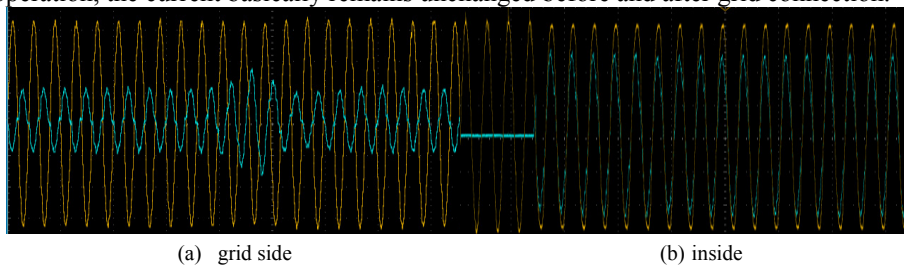

Fig.6. Changeover from mode of direct supply by wind and solar power to mode of energy feedback

(3) Mode of power supply by battery

When wind and solar power generation is insufficient and battery SOC from feedback is below 0.7, the energy management system will automatically stop the power feedback to power grid. In such case the isolated island will enter the mode of supply by battery. The variations of voltage and current are shown in figure 7 during the transition, where the voltage is system AC bus voltage and the current is AC input current on the side of power grid.

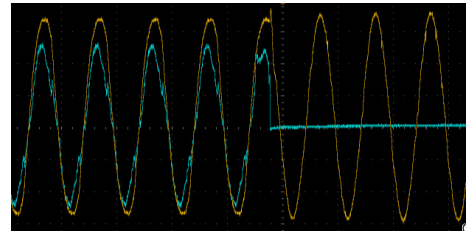
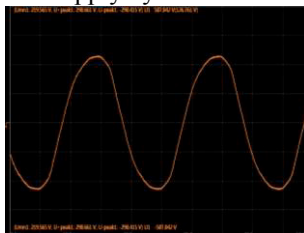

Fig.7. variations of AC bus

(4) Mode of supply by external power

In the mode of supply by external power, the system is connected with grid. The voltage and frequency of the system bus are supported by the power grid. As shown in Figure 8, the voltage waveform is not as good as that in the mode of direct supply by wind and solar power, though it is still a sinusoidal wave. The content of third power harmonic is 7.815%, which is higher than that in the mode of direct supply by wind and solar power. The frequency fluctuates between lower limit 49.9Hz and upper limit 50Hz. The frequency is less deviated than that in the mode of direct supply by wind and solar power.



(a) Voltage waveform

Order	U1 [V]	Uhd1 [%]	Order	U1 [V]	Uhd1 [%]
Tot	216.061	dc	0.062	0.043	
1	215.980	100.000	2	0.050	0.023
3	16.832	7.815	4	0.083	0.039
5	2.236	1.066	6	0.038	0.018
7	1.719	0.798	8	0.049	0.023
9	1.121	0.520	10	0.049	0.023
11	1.031	0.478	12	0.027	0.013
13	0.243	0.113	14	0.012	0.006
15	0.103	0.048	16	0.040	0.019

(b) Harmonic content



(c) Frequency

Fig.8. Quality of electrical energy in the mode of supply by external power

(5) Load limiting mode

In the mode of supply by battery, when battery SOC is below threshold of 0.2, charging initiation would be expected, however, the external power supply is connected for charging. In order to avoid damaging the battery due to excessive discharging, when battery SOC is below 0.1, the energy management system will automatically switch the system into load limitation mode by tripping off the load contactor. During the mode changeover, the waveform of bus voltage and AC output current are shown in figure 9.

When it is possible to connect to the external power supply, the smart micro-grid system will be supplied by external power. In such case, the external power supply only charges the battery. The corresponding waveform for bus voltage and input current of master inverter are shown in figure 10.

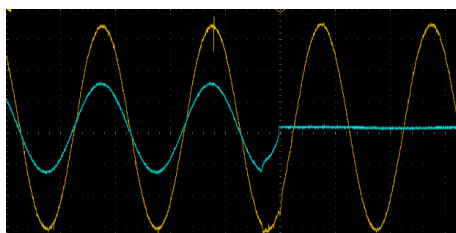

Fig.9. Variations of AC bus

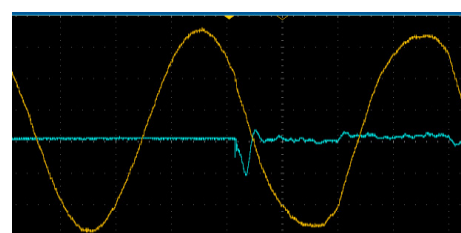

Fig.10. Variations of AC bus

When the external power supply charges the battery so that SOC is greater than 0.15, the loads are automatically connected. During operation, the waveforms for AC bus voltage and AC input current on grid side are shown in figure 11 (a). As shown in this figure, AC input current has increased. External power supply not only charges the battery but also supplies power to the loads. During the mode changeover, the waveforms of AC bus voltage and

output current of the master inverter are shown in figure 11 (b).

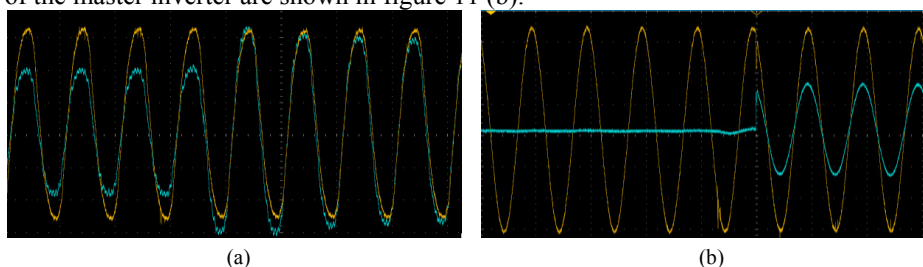

Fig.11. Variation to voltage and current after loads are connected

4. Conclusions

In this paper, a 6kW smart micro-grid system with wind /PV/battery and its control system have been presented. The control system adopts a structure of combining master /slave control and hierarchical control. Energy management system based on battery *SOC* has been developed for the smart micro-grid system with wind /PV/battery, and the functions of measurement and testing, protection, mode changeover, distributed power supply control, load control and energy storage management for the smart micro-grid can be realized. Then, the effectiveness of the control system have been verified in following modes: direct supply of wind and solar energy, energy feedback, power supply by battery, power supply by external supply and load limitation. In all operation modes, smart micro-grid system with wind /PV/battery not only can supply the loads with high quality electricity but also can quickly transfer to a new steady state with a smooth changeover. In future research, cloud service will be applied to control system to realize the remote monitoring and control of the operation state of smart micro-grid.

Acknowledgements

Project by Science and Technology Department of Jilin Province, Project No: 120140004 20150204008SF 20160414027GH

References

- [1] Chen, Z., Hu, Y., “Control of Power Electronic Converters for Distributed Generation Units”, Proc. of the 31st Annual Conference of the IEEE Industrial Electronics Society, IECON 2005, pp. 1317-1322, ISBN: 0-7803-9253-1.
- [2] Chen, Z., Hu, Y. “A Hybrid Generation System Using Variable Speed Wind Turbines and Diesel Units”, Proc. of the 29th Annual Conference of the IEEE Industrial Electronics Society, IECON 2003, Roanoke, Virginia, USA, 2003. pp. 2729-2734 (ISBN: 0-7803-7907-1)
- [3] Wang He, Li Guoqing: Control strategy of microgrid with different DG types, 2012, 32(5):19-23.
- [4] Chengshan W, Peng L. Development and challenges of distributed generation, the micro-grid and smart distribution system[J]. Automation of Electric Power Systems, 2010, 34(2):10-13.
- [5] Olivares D E, Mehrizi-Sani A, Etemadi A H, et al. Trends in Microgrid Control[J]. IEEE Transactions on Smart Grid, 2014, 5(4):1905-1919.
- [6] Tan K T, So P L, Chu Y C, et al. Coordinated Control and Energy Management of Distributed Generation Inverters in a Microgrid[J]. IEEE Transactions on Power Delivery, 2013, 28(2):704-713.
- [7] Zhang Yu, Feng Xinchun, Yu Haojie, etc.: Study on mode switching strategy of wind /photovoltaic/storage micro-grid [J]. Electrical Measurement and Instrumentation, 2016, 53(23):38-44.
- [8] Du Bo, Liu Wenzhou. Research on Control of Energy Storage by Intelligent Micro-grid for Wind/Photovoltaic/Energy Storage[C], 12th IEEE Conference on Industrial Electronics and Applications (ICIEA), 2017. pp. 1087-1091.