



AALBORG UNIVERSITY
DENMARK

Aalborg Universitet

Suction and jacking installation of bucket foundation models

laboratory manual

Koteras, Aleksandra Katarzyna

Creative Commons License
Other

Publication date:
2019

Document Version
Publisher's PDF, also known as Version of record

[Link to publication from Aalborg University](#)

Citation for published version (APA):

Koteras, A. K. (2019). *Suction and jacking installation of bucket foundation models: laboratory manual*. Department of Civil Engineering, Aalborg University. DCE Technical Memorandum No. 74

General rights

Copyright and moral rights for the publications made accessible in the public portal are retained by the authors and/or other copyright owners and it is a condition of accessing publications that users recognise and abide by the legal requirements associated with these rights.

- ? Users may download and print one copy of any publication from the public portal for the purpose of private study or research.
- ? You may not further distribute the material or use it for any profit-making activity or commercial gain
- ? You may freely distribute the URL identifying the publication in the public portal ?

Take down policy

If you believe that this document breaches copyright please contact us at vbn@aub.aau.dk providing details, and we will remove access to the work immediately and investigate your claim.



DEPARTMENT OF CIVIL ENGINEERING
AALBORG UNIVERSITY

Suction and jacking installation of bucket foundation models – laboratory manual

Aleksandra Katarzyna Koterak

Aalborg University
Department of Civil Engineering
Geotechnical Engineering Group

DCE Technical Memorandum No. 74

Suction and jacking installation of bucket foundation models – laboratory manual

by

Aleksandra Katarzyna Koteras

May 2019

© Aalborg University

Scientific Publications at the Department of Civil Engineering

Technical Reports are published for timely dissemination of research results and scientific work carried out at the Department of Civil Engineering (DCE) at Aalborg University. This medium allows publication of more detailed explanations and results than typically allowed in scientific journals.

Technical Memoranda are produced to enable the preliminary dissemination of scientific work by the personnel of the DCE where such release is deemed to be appropriate. Documents of this kind may be incomplete or temporary versions of papers—or part of continuing work. This should be kept in mind when references are given to publications of this kind.

Contract Reports are produced to report scientific work carried out under contract. Publications of this kind contain confidential matter and are reserved for the sponsors and the DCE. Therefore, Contract Reports are generally not available for public circulation.

Lecture Notes contain material produced by the lecturers at the DCE for educational purposes. This may be scientific notes, lecture books, example problems or manuals for laboratory work, or computer programs developed at the DCE.

Theses are monographs or collections of papers published to report the scientific work carried out at the DCE to obtain a degree as either PhD or Doctor of Technology. The thesis is publicly available after the defence of the degree.

Latest News is published to enable rapid communication of information about scientific work carried out at the DCE. This includes the status of research projects, developments in the laboratories, information about collaborative work and recent research results.

Published 2019 by
Aalborg University
Department of Civil Engineering
Thomas Manns Vej 23
DK-9220 Aalborg E, Denmark

Printed in Aalborg at Aalborg University

ISSN 1901-7278
DCE Technical Memorandum No. 74

Table of Contents

1. Objectives.....	7
2. Symbols.....	7
3. Set-up and equipment.....	7
3.1. Safety issues and general comments	8
3.2. Models of bucket foundation	9
3.3. Soil container and equipment.....	11
3.3.1. Hydraulic system	11
3.3.2. Load cell	13
3.3.3. Displacement transducer.....	14
3.3.4. Suction pump.....	14
3.3.5. Small pump	14
3.3.6. Stress sensors.....	14
3.3.7. Mini CPT device	15
3.3.8. Connection piece for the crane	16
3.3.9. The air piston	16
3.3.10. Tools.....	16
3.4. Laboratory water and vacuum access system	17
3.5. MTS system on the computer station	19
3.5.1. 'Station manager'	19
3.5.2. 'Multipurpose Elite'.....	20
3.5.3. 'MTS Data Display'	22
4. Installation procedure	23
4.1. Soil preparation	23
4.2. CPTs before installation	24
4.3. Assembling the bucket	25
4.4. Filling the tank with water	28
4.5. Saturation of PP transducers.....	29

4.6. Suction installation test.....	29
4.7. Jacking Installation test	31
4.8. CPTs after installation	31
4.9. Uninstallation test.....	33
4.10. Removing the bucket model	33
4.11. Direct measurements of soil relative density	34
5. References	37

1. Objectives

The manual describe the set-up and the procedure for testing bucket foundation installation. There are two bucket foundation models with different geometry. The procedure describes both the jacking and the suction installation processes. The set-up including a high soil tank allows to obtain different heights of soil inside the tank at which the model can be tested. The procedure includes the variation of sand densities between the tests. The installation aspects for the bucket foundation can be tested to evaluate if there is any dependency on the geometry of the foundation, different distance to the boundary condition and different soil relative density. The sand tank and the loading frame is a development of the set-up described by (Thomassen 2015), (Vaitkunaite 2015), (Koteris 2017).

2. Symbols

Symbols used through the report are given below:

D	Diameter of foundation model
t	Thickness of foundation model skirt
t_l	Thickness of foundation model lid
L	Length of foundation model skirt
CPT	Cone penetration test
PP	Pore pressure
D_R	Relative soil density
d_s	Specific grain density
e_{max}	Maximum void ratio
e_{min}	Minimum void ratio
d_{50}	50%-quantile
C_u	Uniformity coefficient d_{60}/d_{10}
w	Water content
γ	Soil unit weight
γ_w	Water unit weight

3. Set-up and equipment

3.1. Safety issues and general comments

The safety rules for the AAU Geotechnical Laboratory are described by Vaitkunaite, et al. (2015). However, between years 2017-2018 the laboratory was moved to a new address together with the entire department (<https://www.civil.aau.dk/>). The general and safety rules remain the same.

Most important general and safety rules:

- Working in the lab only in safety shoes;
- Ask technicians for help when having doubts, encountering an error message, breaking a tool/equipment;
- Use helmet when performing a jacking installation, as the piston might bend/break, stop the test if so;
- Clean and return tools that you borrow;
- Use helmet always when someone uses a crane in the set-up.

Working space of the soil tank:

- Use helmet when you climbing on the beam/ entering the working platform on the beams;
- Wear the safety belts connected to the loading frame if you are standing on the edges of the working space;
- For vibration use: helmet, vibration gloves, earmuffs, knee protection (optional). The vibration of 1 hour must be followed by a break or a different kind of work of 1 hour;
- Helmet and gloves are in general recommended for using when working around the testing rig.

General comments when preparing the set-up:

- Always check the length of cables before starting any kind of test. The cables blocked during the test will disturbed/stop the signal for recording;
- Always check if cables are connected and real-life recording in on;
- Remove the small load cell before jacking installation test. The small load cell has a capacity of only 20 kN;
- Be careful while attaching the small load cell by unscrewing it. The cable should not be twisted too much, otherwise it breaks – unplug the cable from the system first and move it around together with load cell;
- Check the PP transducers on the bucket if they work correctly. Calibrate if needed;
- Do not zero down the stress transducers, as they can only be calibrated when there is no sand in the soil container;
- Check if the piston is stable while doing CPT (especially with extended arm). When the piston is bended, the results of CPTs are not reliable. Fix the bolts from the load cell or piston so it will be straight.

3.2. Soil properties

Baskarp Sand no. 15 is used for testing of bucket foundation installation. Sand has been previously tested at Aalborg University by Borup and Hedegaard (1995). Based on the results of classification tests, soil basic parameters are described in Tab. 3.1.

Tab. 3.1. Properties of Baskarp Sand No. 15

d_s [g/cm ³]	e_{max} [-]	e_{min} [-]	d_{50} [mm]	C_u [-]
2.64	0.854	0.549	0.14	1.78

3.3. Models of bucket foundation

Two models of bucket foundation are used, see Fig. 3.1.

- a round model
- and a modular model.

The bucket skirt in both cases is equipped with small channels ending at different heights: 1/3, 2/3 and 3/3 of the total height. PP1-PP3 are located on the outside skirt, PP4-PP6 on the inside skirt, and PP7 is situated under the lid. These channels are connected to PP transducers during the set-up. The lid of bucket is equipped with 4 valves. Valves can be used for the suction application, and in order to perform CPT inside the bucket after the installation. The central part of the lid with a connection piece for the piston is switched between bucket models and fixed to the rest of the model.

Tab. 3.2. Geometry of foundation models and location of PP transducers

Model	D [mm]	t_i [mm]	t [mm]	L [mm]	Weight [kg]	PP location from the skirt tip [mm]
Round	1000	20	3	1000	214	tip / 330 / 665
Modular	~1000	20	1.7	988	244	tip / 316 / 652

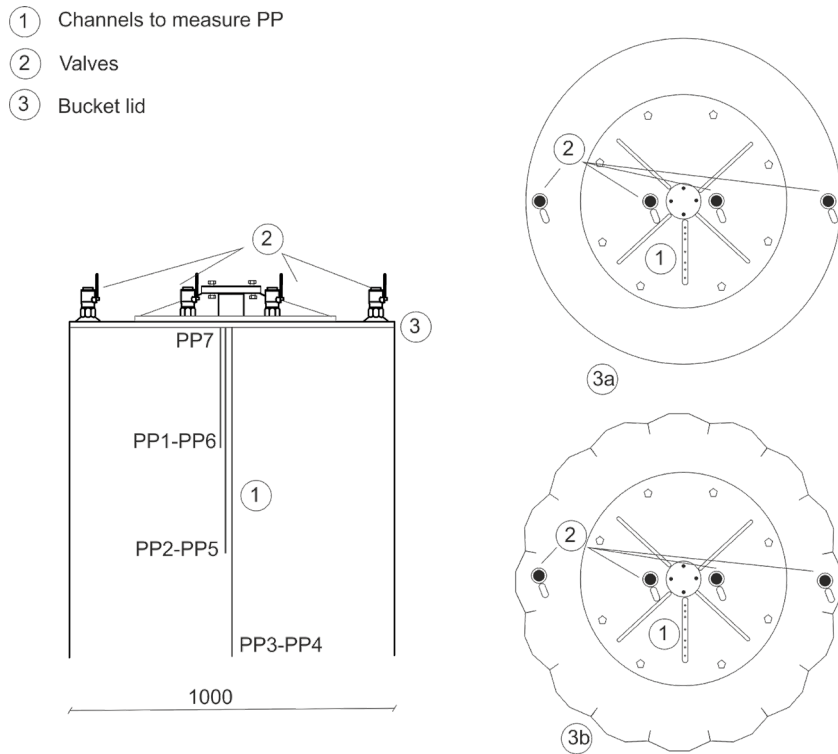

Fig. 3.1. Bucket foundation model: a round model (a) and a modular model (b).

The modular bucket consists of 7 sections with one internal stiffer in each section. The stiffer begins 100mm above the skirt tip. The section can be divided into 3 elements of trapezoid connection, where only one is ended up with a stiffer. Dimensions of such element with a stiffer is shown in Fig.3.2.

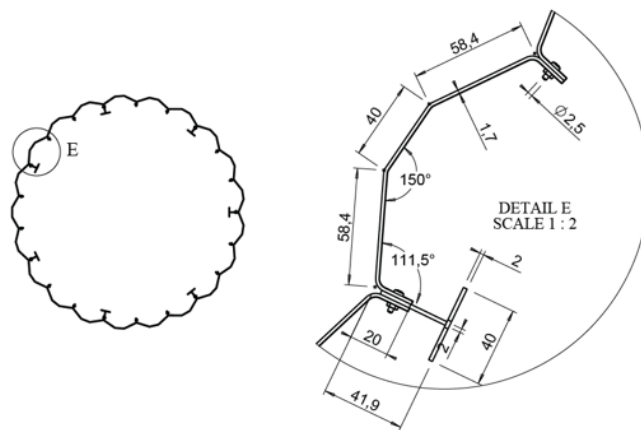

Fig. 3.2. Dimensions of the element with a stiffer.

3.4. Soil container and equipment

Fig. 3.2. presents the sketch of the laboratory set-up used for testing. The main element is a soil container filled with sand. The container is 2.5m of inside diameter and 3.52 m of height. The bottom is prepared for drainage: perforated pipes equally placed at the bottom cover by the gravel layer of 0.3 m height and a geotextile cloth. The sand is filled to be a layer of 2.1 m height, which can be reduced due to vibration or increased by filling extra sand. The working space is situated on the height of approx. 2.5 m, which requires an access ladder.

Water can access the soil container from the top or from the bottom of container. The vacuum can be accessed on the working platform through the access point. Both water and vacuum come from the laboratory system.

The model of bucket is installed into the sand by hydraulic piston fixed to the loading frame. For the installation, the bucket model is connected to the PP transducers situated on the top of the soil container. PP transducer sometimes requires calibration. The calibration process is described by (Koterias 2017) and the calibration scale factor should be inserted in 'Station Manager', see sec. 3.6. Displacement is measure by the displacement transducer and load is measure on the load cell.

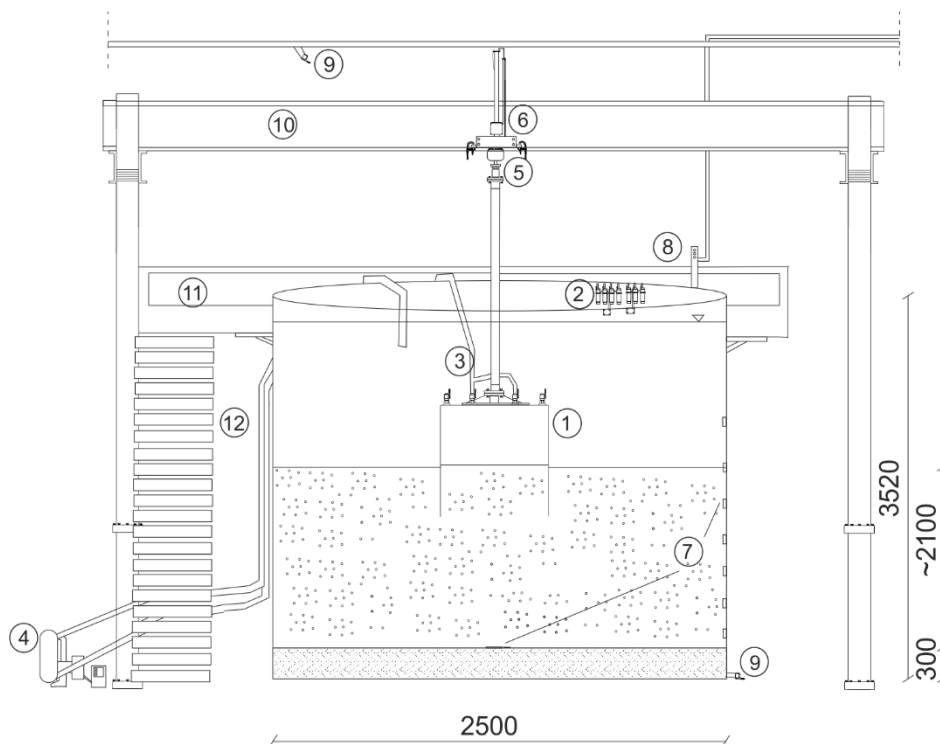

Fig. 3.3. Laboratory set-up: (1) Bucket model, (2) PP transducers, (3) Pipes for the suction application, (4) Suction pump, (5) Load cell on the loading piston, (6) Displacement transducer, (7) Stress sensors and PP transducers, (8) Vacuum access point, (9) Water access points, (10) Loading frame, (11) Working platform around the soil container, (12) Access ladder.

3.4.1. Hydraulic system

Hydraulic system contains a piston, hydraulic pump, control and setting switchboards and a manual pilot for control, see Fig. 3.3. The piston is connected to the hydraulic

pump. The piston can work as a deformation speed (the small or the big load cell) or as a load speed (only the small load cell). The adjustments of the system are therefore required according to the control used.



Fig. 3.4. Hydraulic system: hydraulic pump, control switchboard, setting switchboard and manual pilot for control (from the left side respectively).

The middle black knob on the control switchboard allows for the change between the load control and displacement-control of the piston. The upper part of the board is used for the displacement-control: the set-point value can be chosen and the feedback can be read. The lower part of the board is for the load-control option: set-point load speed and the feedback. The settings should also be changed on the control switchboard according to correct control gains. P-41 and P-42 should be changed dependent on the control:

- for displacement control **P-41** is 0.1 and **P-42** is 0.5
- for the load control **P-41** is 3.0 and **P-42** is 1.0.

To choose P-gain the middle button in the upper row should be hold. When the P-gain number is shown, use the arrows up and down to find a gain to be changed. Use the middle button again to switch between the values. For the load-control the motor must be opened. Turn the knob on the motor around 2.5 of the entire rotation.

There are many steel extension pieces of different heights for the piston, see Fig. 3.4. They can easily be mounted by screwing one piece into another. The connection between each part does not to be completely tightened. The first and last element is equipped with a connection piece that can be fixed to the upper part of the piston and to the bucket model with bolts and nuts. Use pipe wrenches to untighten the pieces (keep the upper piece with one wrench while moving the lower piece with another wrench).

However, for the jacking installation it is important to use the longest element from the connection piece, and use only this one or add one short piece if needed. The connection must be stiff enough and do not bend when applying a big jacking load. The connection places between elements are the once that bend first, so they should be avoided if possible.



Fig. 3.5. The extension pieces for the piston

3.4.2. Load cell

There are two load cells that are used in this set-up. The big load cell is attached permanently and has the capacity of 250kN. It can only be controlled as a deformation speed. The small load cell can be attached/detach to the piston. It is connected to the hydraulic system and allows the piston to work as a load speed control. However, the capacity of the small load cell is only 20 kN, and therefore the small load cell must be removed for the jacking installation where the applied force is exceeding this limit. Both are connected to acquisition device for recordings.

The small load cell can be attached to the connection round disc below the big load cell. The round disc from the small load cell is smaller, however it does have appropriate holes to tighten it with screws. As the space between the small connection disc and the small load cell is limited, the load cell can also be unscrewed under this disc by rotating it before fixing the disc connection. After all it can be screwed again by rotating. Do not twist the cable as it might break.



Fig. 3.6. Both load cells on the piston (left picture) and the connections on the small load cell (right picture)

3.4.3. Displacement transducer

A displacement transducer is situated on the loading frame and connected to the top of the piston measuring its dislocation. Signal is acquired in a data acquisition device and can be recorded on the computer. Maximum extension is 1250mm.

3.4.4. Suction pump

A suction pump is used for the application of differential pressure under the bucket lid. LSM pump type 32 is used for the set-up. The pump extract the volume of water per minute that is chosen through setting the rotation per minute. For example 26 RPM gives a pump speed of 32,8 l/min.

The middle knob is used for starting the pump; it should be switched to REV or FWD (reverse or forward direction). Always check which direction causes suction in which pipe. There are two pipes connected to the pump. One of those pipe should be connected to the bucket lid for suction application, whereas the other pipes should be fixed on the top of soil container and inserted into the water.



Fig. 3.7. The suction pump and the setting switchboard for the pump (left picture) and the small pump (right picture)

3.4.5. Small pump

There is an extra pump that can be used to remove the water from the soil container – from the top side. The pump is inserted into the water and pumps out the water until a buoy is situated above the bottom of the pump. It is a good idea to fix the buoy to a hose/cable. The hose end should be directly positioned in a drainage grate. Put some weight on the hose as it the pressure is quite big and the hose can move and the water will be spilt around the lab. The pump works when cable is connected to the socket.

3.4.6. Stress sensors

There are 8 total pressure cells and 8 piezometers in the soil container. The total pressure cells measure the total soil pressure, H0-H7, and the piezometers measure the soil pore pressure, P0-P7, through the strain gauges. One of each is placed on a geotextile cloth (bottom of the sand layer). The rest of them is attached to the soil container wall, see Fig. 3.7. The signal acquired in *mA* is transmitted into *kPa* through calibration factors.

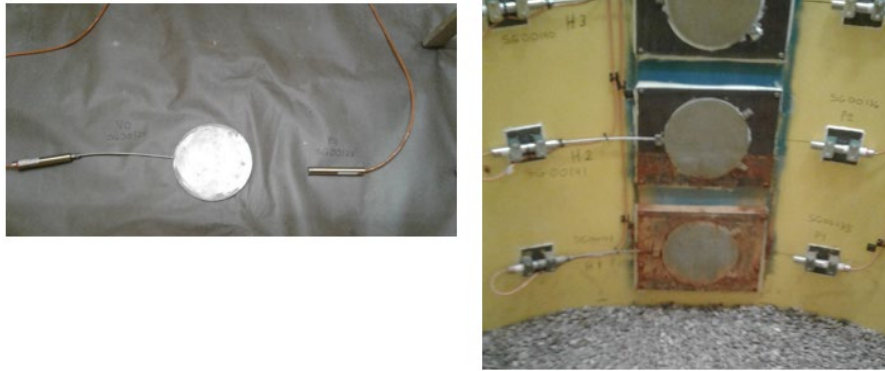

Fig. 3.8. The total pressure cell and the piezometer placed at the bottom of sand layer (left) and the first 3 pairs of cell and piezometer on soil container (right)

The first pressure cell is situated at the height of 300mm from bottom and measure the vertical stress. Then the rest of cells situated at the wall are placed in a distance of 233mm from the first one, and then each 383mm. The locations of piezometers are the same.

3.4.7. Mini CPT device

The CPT device has a total length of 1.25 m (with a safety factor it can only move by 1.17m). The cone has a diameter of 15mm and inclination of 30°. The resistance is measured by a load cell made of 4 strain gauges coupled in a full-bridge connection, placed just below the cone. Soil parameters can be derived from cone resistance based on (Ibsen et al. 2009). There is an extension piece for the CPT device which allow to attach the device on the arm that can be slightly rotated. This can be used for performing the CPTs inside the valves if the bucket is slightly rotated and the valves are not in a reference line to the loading frame. Attached CPT and extension arm is shown in Fig. 3.8. Procedure for calibration of CPT is described by (Koterias 2017), and the new calibration scale factor can be inserted in 'Station Manager', see sec. 3.6.



Fig. 3.9. The attached CPT device and the extension arm for the CPT.

3.4.8. Connection piece for the crane

The connection piece must be attached to the bucket model with 4 bolts and nuts (one should be a long bolt). Attach the tape and then hang on the crane.



Fig. 3.10. The connection of the bucket model on the crane; the air piston

3.4.9. The air piston

Situated on the wall, in some locations around the lab. Used to clean the connection channels on the bucket model for PP measurements.

3.4.10. Tools



Fig. 3.11. Tools used in during the preparation and tests

The remaining tools used in the set-up:

- A shovel: adding sand; levelling sand surface
- A small shovel: taking out soil sample
- A rubber broom: levelling
- A measurement tape
- A tape: marking CPT to get a desired depth
- Clamps: fixing piston; fixing hose to the container
- Wrenches of different size
- A socket wrench big and small: for holding bolts and tightening a steel rings on the hoses
- A pipe wrench: for disconnecting extension pieces from the piston
- Allen keys (a short one is designed for the small disc of small load cell)
- Bolts and nuts

3.5. Laboratory water and vacuum access system

The system for water and vacuum access is situated on the floor above the working platform. This gives a bigger water head access when the hydraulic gradient is applied. The system included the water tanks, the vacuum tanks and valves for opening/closing the access for the vacuum. The control of water and vacuum system is possible on the setting screen situated next to the computer station. There are switches for system valves above the screen.



Fig. 3.12. The setting screen for water and vacuum access

When the screen is touched, the settings are displayed. The touch button in the right upper corner allows changing between deoxygenation and vacuum tanks. Most of the time the deoxygenation should be in 'Auto' mode. This means that the water tanks are being automatically filled and water is heated and deoxygenated. For using the vacuum this process must be stopped. Click on the green 'Auto' touch button. It changes to the

red 'Stop'. Change to vacuum tanks in the right upper corner. Change the touch button 'Stop' to 'Auto' and 'Vacuum off' to 'Vacuum on' by clicking.

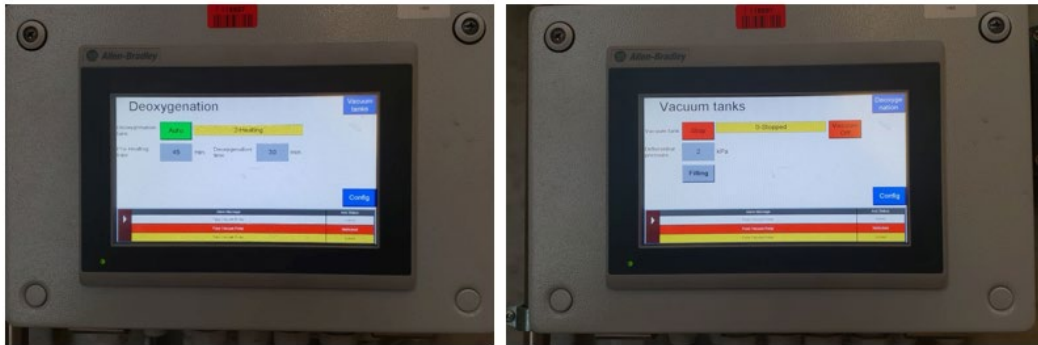

Fig. 3.13. Deoxygenation and Vacuum tanks settings.

The switches controlling the valves nr.4 and nr.5 situated above the screen must be switched down. The increasing vacuum pressure is observed on the pressure gauge above the switches. Then the vacuum can be accessed on the working platform, Fig. 3.14, by opening the valve. The vacuum is access through the small transparent tube. Remember to turn off the vacuum always after using it.



Fig. 3.14. The vacuum access point on the working platform

In order to fill the soil container from the bottom, or to apply the hydraulic gradient, use the hydraulic pump situated behind the container. The pressure is set on the control switchboard, Fig. 3.14., where the green number is the desired pressure (use arrows for increase/decrease), and the red number displays the applied pressure. If the valve situated next to the pump, valve 4, is closed, the pressure available from the water tank is displayed. If this valve is open, and there is an access to the soil container, the pressure inside the soil is presented on the display.

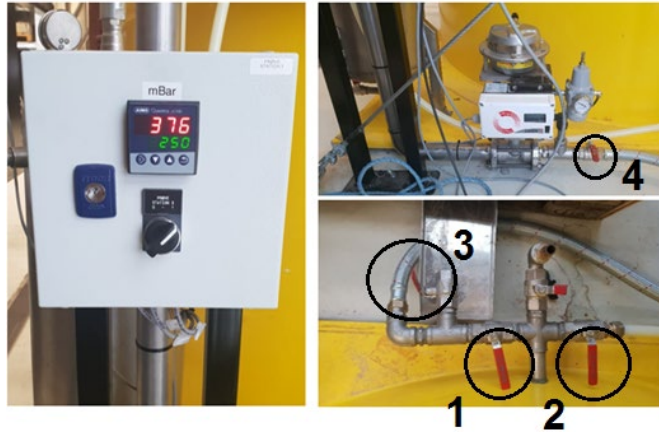

Fig. 3.15. Control of water accessing the soil container: the control switchboard for water pressure, the hydraulic pump (upper picture) and access pipe for the container (lower picture).

To have an access to the soil container, valve 1 must be opened. Valve 2 is for vacuum access. Valve 3 can be used in order to remove the water from the system.

Important!

When the water container is empty and filled again with the water, the air must be release from the hose before coming into the sand container. The valve letting the water out, valve 3 in Fig. 3.10., should be open until the water will come (the whole hose will be then filled with the water).

3.6. MTS system on the computer station

The signals from measurements are acquired through the data acquisition device and transmitted to the 'Station Manager' accessed on the computer. The live-records can be read through 'Station Manager', but the time history can be displayed also in 'MTS Data Display' program. The data can only be saved through 'Multipurpose Elite' program.

3.6.1. 'Station manager'

- Opening the program and Acquisition Manager:



- 'Enable Data Acquisition' should be on (round blue mark in the toolbar)
- Go to 'Data Acquisition Channels' in the upper option-bar. All available channels for recordings are visible here.

- The options available through the lower option-bar: 'Range', 'Limits', 'Conditioning', 'Offsets', 'Filters', 'Calibration', 'Input Resource', 'Review Limits'

There are many options in the bars, and the program is multi-layered, what means that many settings can be change in a more than one way. Below, the most common used options are presented.

- To 'zero down' channel – go to 'Offset' and click on 'Zero Auto' tick. More than one channel can be marked for zeroing channels together. DO NOT ZERO DOWN channels H0-H7, P0 – P7, as they can only be calibrated when sand is not in the soil container.
- For calibration (often for PP1-PP8) go to 'Conditioning'. Change the 'Scale Factor' if needed. This can also be done in 'Calibration' – 'Two point calibration' by setting the first point (lower-pressure value), and second point (higher-pressure value).

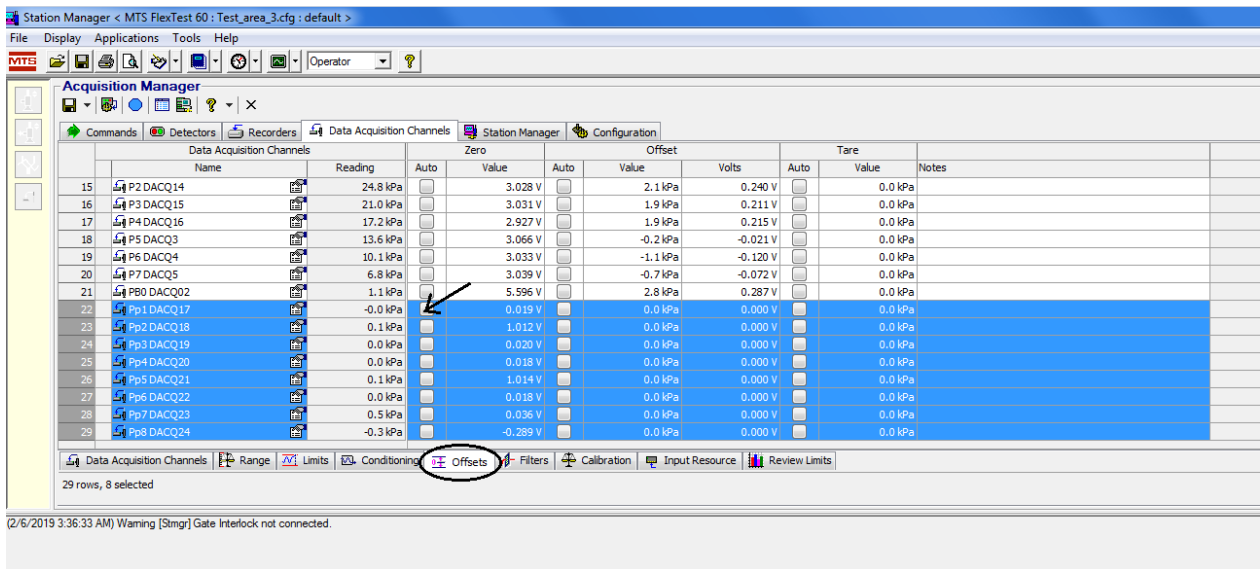
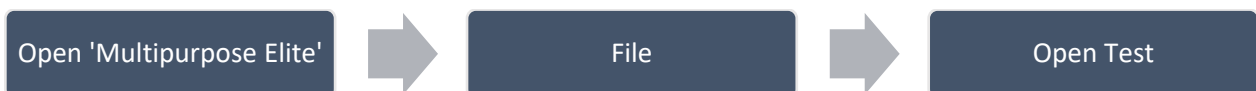

Fig. 3.16. Zero-down channel in Station Manager

The program must run and 'Data Acquisition' must be enable in order to start 'Multipurpose Elite' for saving the data during a test. However, when the 'Multipurpose Elite' is on, no changes can be made in 'Station Manager'. Therefore, the calibration and the 'zero-down' process must be performed before opening the 'Multipurpose Elite'.

3.6.2. 'Multipurpose Elite'

- Opening the program:



- Available tests: 'CPT_1', 'CPT_2', 'Installation', 'Vibration'
- Reset controller and program interlock
- Set the Power to be 'All power high' (first click 'All power low', and then 'All power high')

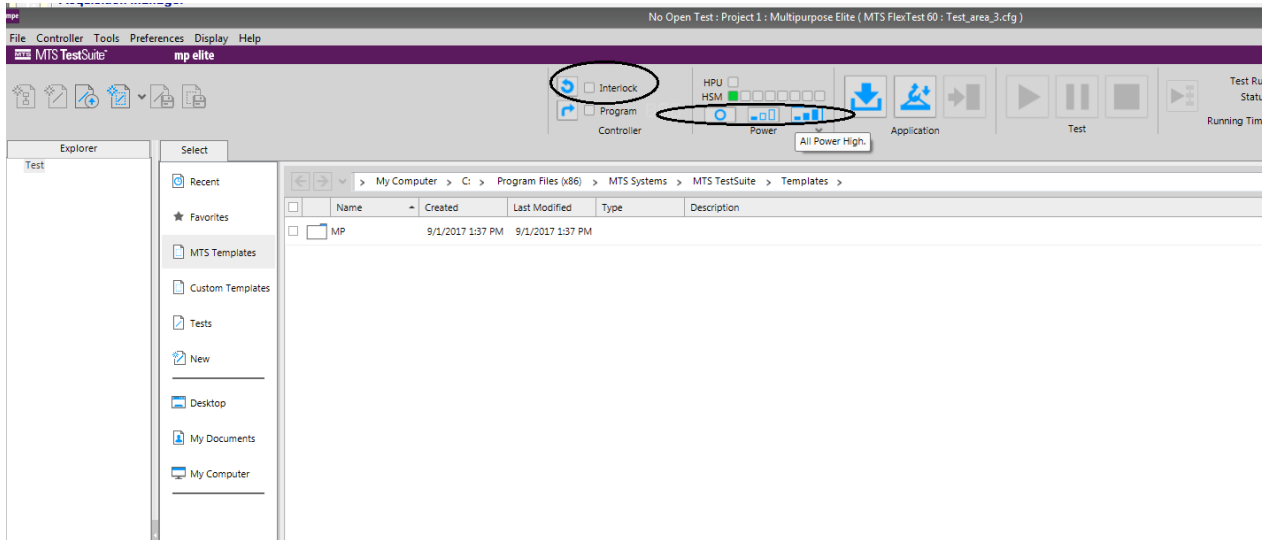

Fig. 3.17. Starting the 'Multipurpose Elite': 'Interlock' and 'All Power High'

'CPT_1' and 'CPT_2' are programs for short and long CPT respectively. Records being loaded and saved are: time, displacement, CPT and load. 'Installation' is used for installation test, both jacking and suction. Records being loaded and saved are: time, load, pressure from transducers: H0-H7, P0-P7, PB0, PP1-PP8 and displacement. For 'vibration' the time is recorded and signals from transducers on the soil container: H0-H7 and P0-P7.

To start new test, click on 'New Test Run' displayed in the left upper corner. This can only be access if a test is open. Then a window named 'Specimen Selection' is displayed – click OK. Next a window named 'Startup Variables' is opened – click OK. To start loading the data click on green button 'Run the test'. The time will start running and data are loaded. Double-check if the data is recorded before starting the test on the set-up. When the test is finished click on ' FINISH AND SAVE THE TEST' button below the toolbar.

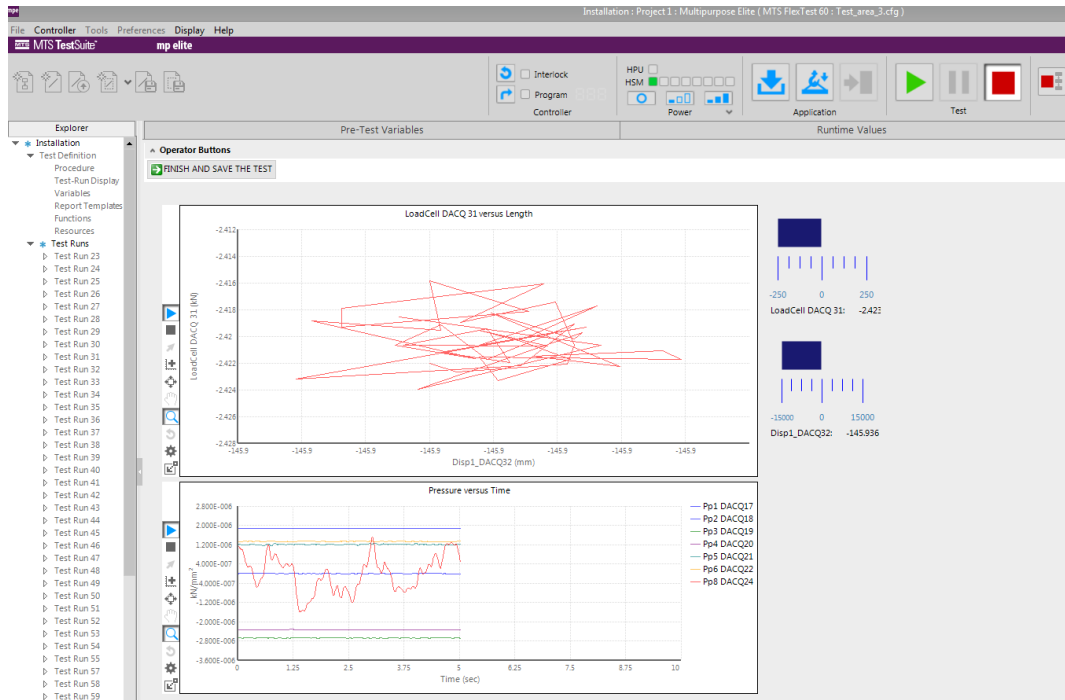

Fig. 3.18. Running test in 'Multipurpose Elite'

Instead of choosing an existing test, a new test can be set. Create a new test from the 'File'. Go to 'Explorer' strip, first from the left side, where in a 'Procedure' a new test can be designed. In 'Procedure' options available are 'Comments', 'Data Acquisition', 'Event detection', 'Operator entry', 'Program Actions'. This allows programming the test actions and loading/saving the data. There are some descriptions with each button.

In 'Explorer' other options can be chosen. Two often used options: 'Test-Run Display' to choose what data we want to observe during the test, 'Resources' to import some new resources if needed (new channels), or to remove resources not needed that sometimes are automatically activated. Click on 'Import Resources' – 'Import All Unused Controller Resources'.

3.6.3. 'MTS Data Display'

The program can run all the time. To open and access the plots used:

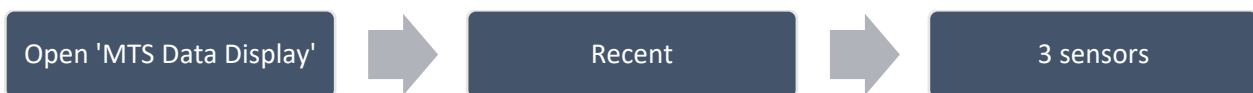

In this program new plots, meters, list views can be created by clicking in the background of workspace with a right mouse button.

4. Installation procedure

4.1. Soil preparation

- Add missing sand / level the surface

The vibration procedure decreases the void ratio of sand volume, thus might lead to a lower soil surface. This is valid especially when vibrating a loose or medium dense sand. If the soil level has been lowered significantly in the previous test, extra sand must be added. The level of soil surface should be close to the lowest level of the supporting brackets that is used for the beams. As the piston extension is limited, keep the distance between the skirt tip and the soil surface as small as possible (keeping also the piston in the highest possible position).

During the test, the sand in the middle is moved upward or downward depending on the installation/uninstallation method. Level the center surface of soil.

For leveling and moving bigger volume of sand use a rubber broom and a shovel. The level of the water should be 1-2cm above soil surface which makes levelling process easier.

- Apply the hydraulic gradient

The hydraulic gradient equal 0.9 is applied to the soil volume in order to loosen it a bit and redistribute the soil particles. The water used for the gradient is from the laboratory water system. The water enters the tank from the bottom. The valve next to the hydraulic pump, valve 4, is open, and the access valve for the soil container, valve 1, is open (Fig.3.14.).An appropriate pressure is set on the control switchboard for water pressure

The gradient pressure is calculated from the present water level. The pressure head height of existing pressure must be increased by 90%. So the water pressure entering the tank should correspond to the water head equal to 1.9 of the existing head.

Example: The water level in tank is equal to 2.5m, the pressure applied must correspond to: $1.9 \cdot 2.5m \cdot \gamma_w$.

The hydraulic gradient of 0.9 is applied for approx. 10 minutes. Observe the soil surface while applying the gradient; do not allow the small piping channels developed. If they are observed, lower the pressure and vibrate the location of the pipe first, before starting the vibration process. During the vibration process, this spot should be vibrated again by following a vibration procedure.

- Vibration

Prepare the vibration working platform. Use aluminum beams on the supporting brackets above the soil surface and put the wooden platform for vibration on them, see Fig.4.1. It is important to set the parts as shown in figure; otherwise some of the holes might be blocked by beams and impossible to vibrate in them. Two main parts of the vibration platform are situated on the floor and must be transported to the soil tank with the crane. The middle small part of the wooden plate is situated on the working platform around the soil tank. The vibrator must be attached to the crane and moved up, situating it in the corner, at the approximate height of 1.5m above the platform, see Fig. 4.1.



Fig. 4.1. The vibration procedure: the beams below the platform, the vibration platform and the vibrator hanging on the crane

To transport both the platform and the vibrator, the violet tape is used to connect to the crane, see right hand side picture in Fig. 4.1. When using the crane remember about the safety use. Ask technician for help when using the crane, unless you were instructed how to use it.

When vibrating remember the safety rules and the protection, see sec. 3.1. Push the rod vibrator into the sand slowly for a depth of approx. 1m. Then pull the rod slowly back. When vibrating follow the same order: start from the side opposite to the transducer situated on the inside of soil tank. Vibrate every second hole in a zig-zag shape, following each row. Do not vibrate in the last row, which is too close to the transducers. On the way back, vibrate every second hole that remained. The rod should be force down a bit, depending on how dense is sand. Vibration proceed much smoother in loose sand. If the rod starts to twist a bit, allow for it. If the rod is forced too much to go straight down, it might break.

When the vibration is finished, check the surface level in the center. If the water raised much during gradient application, it can be removed from the top by using a simple pump. Water can also be removed from the bottom, but only by opening the valve less than its 50% capacity. A slow downward flow will not change the soil properties. To do that, open the valves accessing the tank (valve 1), and the valve allowing the water to be removed (valve 3), see Fig.3.14. Level the soil surface if needed.

Remove the vibrator, the platform and the beams. Allow sand to settle for a while.

4.2. CPTs before installation

4 CPTs are performed to check the uniformity of the prepared soil. The water level should be close to the soil surface; 2-5cm above soil surface. The positions for CPT are marked on the back of loading frame as black caption 'CPT1- CPT4'. They are situated approximately 30cm and 70cm on both sides from the center. The piston is moved to each position and fixed with 2 clamps.



Fig. 4.2. The piston clamped with two clamps in opposite corners

The extension piece and the CPT device must be attached to the piston. The length of extension piece should be selected properly, so the maximum length range of the piston is ensured for around 110 cm of CPT. The cone of CPT device should be situated just above the soil surface before the test starts, with piston being in its maximum height. Remember that the piston itself has a range 117 cm. Check if the CPT device is not bended and ask technicians for help with strengthening it before the test.

The CPT is a 'displacement-control' test. The setting for the hydraulic piston must be adjusted for this mode. The settings are changed on the control switchboard and the setting switchboard for the hydraulic piston and the hydraulic motor should be closed, see sec. 3.3. The 'Set-point' for the displacement on the control switchboard should be 5 mm/s.

Zero-down the displacement and CPT resistance in 'MTS' (sec.3.6). Afterwards, start measurements in 'Multipurpose Elite' (sec. 3.6.). Start the test by starting the penetration with the manual pilot - 'down'. The switch on the pilot should be on the option 'slow'. The head of CPT where the cable is connected is not waterproof, so it cannot be submerged to the water. The test is finished when reaching around 110cm penetration in sand. Finish and save data in 'Multipurpose Elite'. The CPT can be moved up with a 'fast' mode on the manual pilot.

The soil parameters that can be derived based on CPT are described by (Koterias 2017). Those parameters are void ratio, friction angle and dilation angle. D_R is calculated based on void ratio results.

4.3. Assembling the bucket

Prepare the soil container for moving the bucket model inside it. Use two black aluminum beams of square section and two of wooden platforms to prepare the support deck at the lowest level above the soil surface. Move the hydraulic piston on the side to make a space for transportation of the model. One clamp can be used to hold the piston in the desired position.

Prepare the bucket model.

- The channels on the bucket skirt for measuring the PP must be cleaned with the air – use the air piston on the outlets situated at the lid.
- Removed the sand attached from previous test.
- Check if the valves on the lid are tightened.



Fig. 4.3. Moving the bucket model to the soil container

Use the crane to move the bucket from the floor to the tank. Remember about the safety rules while using the crane – ask technician for help if you have not been instructed how to use it. The bucket should be placed in the center of the tank. The valves should be in a line with reference to the loading frame. In the last step of removing the bucket to the platform, it should be pushed to the center by hands, as the loading frame is limiting the access to the center by crane only. The connection piece for the crane transport should be removed by using a suitable wrench for the bolts.

For connecting the hydraulic piston to the bucket model, the small loading cell must be connected/disconnected depending on the testing method. Additionally, the maximum extension piece for the piston must be added - remember one long piece for jacking test.

Prepare a working platform at the top of the container by placing two aluminum beams with rectangular section into the supporting brackets at highest level. Put the wooden platform at the top.

Working from the higher platform:

A correct load cell must be used depending whether the suction or the jacking installation test is performed. The big load cell is always in its position – do not remove it. For the suction installation test, attach the small load cell below the big load cell. Only the small load cell is adjusted for 'force-control' installation, which is necessary for the suction installation. On the other hand, the small load cell can only hold 20kN, therefore **it must be removed for the jacking installation.** See section 3.4. on how to attach the small load cell.

The piston should be moved to the center and clamped with 4 clamps.

Working from the lower platform:

The extension piece/pieces should be attached to the piston, so the maximum length range of the piston is ensured for the installation. When matching the extension pieces,

the piston should be at the highest possible position. When the extension piece is attached, zero down the load in 'Station Manager' (this does not have to be done before each test but only when change between load cells and bucket models). After attaching the bucket model the display for the load will show the self-weight of the bucket.

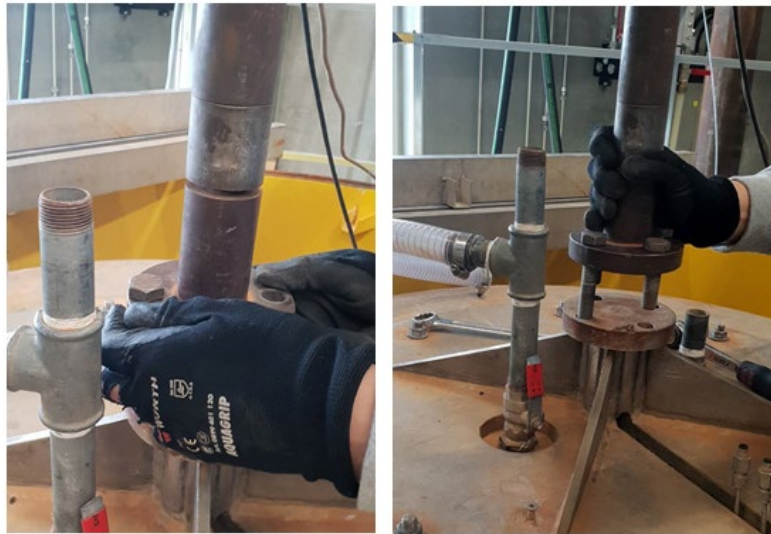

Fig. 4.4. Attaching extensions piece of the piston and connecting the piston to the bucket's connection piece

Both the end of extension piece and the top of the bucket are equipped with a connection disc part. Join both parts with the use of bolts and nuts, using an appropriate wrench. First, the piston should be moved down until those parts are aligned. Then fixed connection pieces with 4 bolts: keep the bolt or nut with a socket wrench from one side, while tightening the other side at the last stage.

Connect the plastic pipes from PP transducers to the outlets at the bucket lid according to the numbers. The connection must be tight so there is no air entering the pipes while saturating.

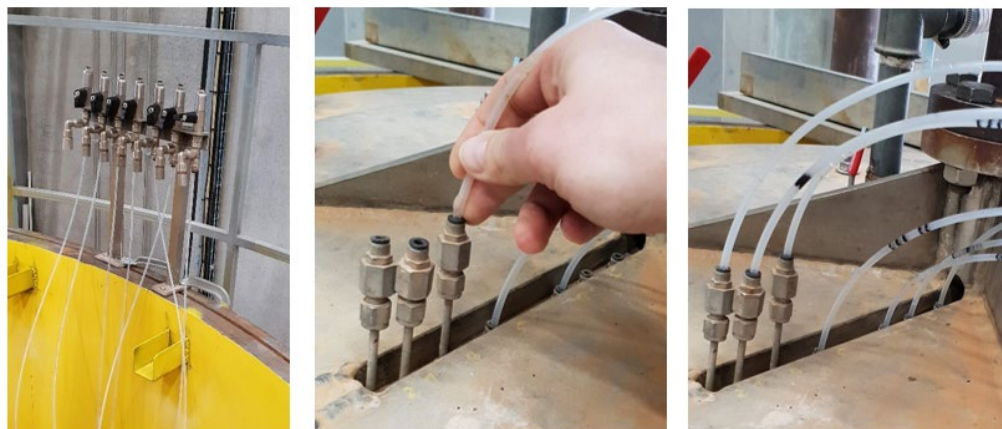

Fig. 4.5. PP transducers on the soil container, connection of pipes to the lid outlets

If the test is a suction installation, connect the hose from the suction pump by placing it at the middle valves. A steel ring should be tightened on the connection place between the hose and the valve. Use a small socket wrench for tightening/ untightening. For jacking installation, the valves should remain open.

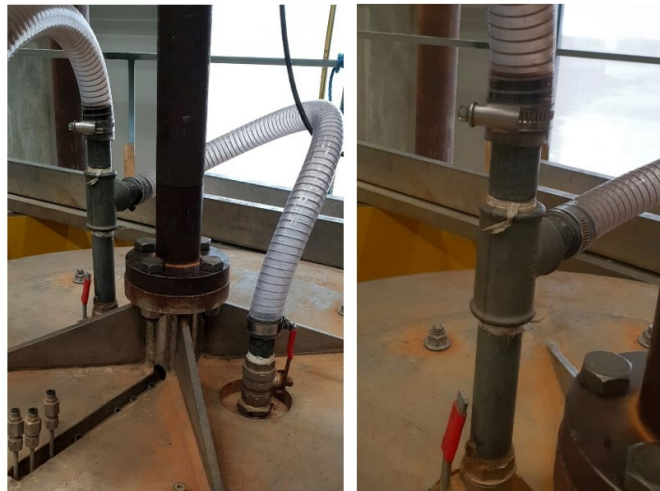

Fig. 4.6. Suction hose connection with two middle valves

Moved back the piston to upper position to remove platforms and the beams. The piston should then be moved down so that the skirt tip of the bucket is around 2-3cm above the soil surface.

4.4. Filling the tank with water

Installation test is performed for submerged (or almost submerged) model. Fill the container with water. To not create the gradient inside the soil, the water must be filled from the top. A plate should be placed on the soil surface. There is a water access from the working platform, see fig. 4.7. Control the level of water, not to spill the water from the tank by overfilling. The water should be close to its maximum level, so that the lid can be covered.



Fig. 4.7. A plate on soil surface for filling the water and water connection from the working platform

While filling the water the valves on the bucket must be open so there will be no pressure created inside the bucket. The pressure inside could cause some tilting of the bucket.

4.5. Saturation of PP transducers

The ends of channels for measuring PP at the bucket skirt must be submerged in a water prior to the saturation process. If the lid is not submerged (PP7 is not inside the water), the saturation can only be done for PP1-PP6. PP7 should be saturated after the self-weight installation phase. Remember not to saturate PP3-PP4 after self-weight installation, because the ends of channels will be already inside the soil. The data could be saved in one file (remember to write down when PP7 was saturated so it can be zeroed down while analyzing the data), or in two files if PP7 should be zero down in 'Station Manager' program.

The saturation is performed with the vacuum from the laboratory vacuum system. The vacuum should be switch on, see sec. 3.6. Connect the thin plastic tube from the vacuum access point to the top of PP transducer. Open the valve on the vacuum access point, next open the valve on the transducer. The tube works now as a suction pipe and sucks the water through the transducer. The process ends by closing the valve on the transducer when there is a pure water run observed, without air bubbles.

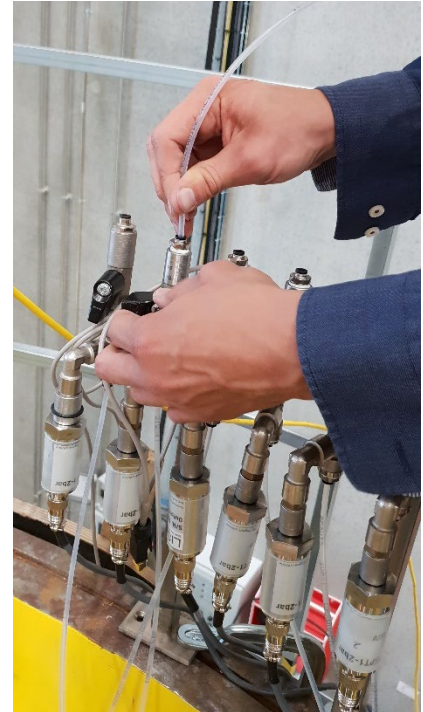

Fig. 4.8. Saturation of PP transducers

- If bubbles are observed constantly, check the connection on the bucket lid. Not enough tight connection of the pipes to the holes at the lid is the most common reason why the air is present.
- If the end of the channel on the bucket skirt is not submerged into a water, the air is sucked instead of water and the transducer is not saturated.

Repeat the process for each transducer. When finished, close the valve in the vacuum access point at the working platform and close the vacuum system.

4.6. Suction installation test

Perform self-weight installation in a first place. The tests can start only when:

- PP transducers are connected to the bucket and saturated.
- The suction pump is connected to the bucket and the direction of suction is checked. The pumping rate can be chosen based on [m³/min] value.



Fig. 4.9. Clamped outlet hose from suction pump

➤ The outflow hose from the pump is clamped at the container. Water should go back to the container while being pumped through the bucket lid ensuring a constant water level inside the tank.

➤ The valves on the bucket must be opened.

The test is performed as a 'force-control'. The setting for the hydraulic piston must be adjusted for this mode. The settings are changed on the control switchboard and the setting switchboard for the hydraulic piston and the hydraulic motor must be turned, see sec. 3.4.1. The 'Set-point load speed' on the control switchboard should be set to zero.

Run the test in 'Multipurpose Elite', see sec. 3.6. Start the penetration of the bucket with manual pilot by pushing button 'down'. The switch on the pilot should be on the option 'slow'. Slowly increase the 'Set-point load speed' on the control switchboard to reach the value displayed as a 'Feedback value load speed'.

Observe the bucket model, it should not start moving too fast. Decrease the set-point load slowly to zero as the load value read from the data display is also close to zero. The load from data display should decrease from the self-weight bucket on minus until it fluctuates around zero as the bucket penetrates. Do not stop the installation on the manual pilot, but only set the set-point load value to zero.

When there is no significant displacement, the suction installation can begin. For suction installation:

- The set-point load should be zero;
- Close the valves at the bucket lid;
- Start the pump by choosing correct direction: REV or FWD;
- Control the load on the switchboard – set-point load should be between 0.16-0.18 kN. This allows for the lowest possible fluctuation of the load.

The applied suction starts penetration again. The load at the beginning fluctuates a lot between large value, but shortly after it starts to be more stable. By keeping the set-point load value on around 0.18kN, the fluctuation reduces and the suction installation proceeds.

Installation is in a final stage, when there is no more displacement but only increase in total penetration load. Remember to stop the test and save data in 'Multipurpose Elite' program.

4.7. Jacking Installation test

The tests can start only when:

- PP transducers are connected to the bucket and saturated;
- The small load cell is removed from the piston and one long piston extension element is used;
- The valves on the bucket are opened.

The test is performed as a 'displacement-control'. The setting for the hydraulic piston must be adjusted for this mode. The settings are changed on the control switchboard and the setting switchboard for the hydraulic piston and the hydraulic motor should be closed, see sec. 3.4.1. The 'Set-point' for displacement on the control switchboard should be 0.28 mm/s. This gives a penetration speed of 1m/hour.

Run the test in 'Multipurpose Elite', see sec. 3.6. Start the penetration of the bucket with manual pilot by pushing button 'down'. The switch on the pilot should be on the option 'slow'. Installation is in a final stage, when there is no more displacement but only increase in total penetration load.

The big load cell has a capacity of 250kN and included some safety factor. Therefore, the maximum reached force is around 180kN, which is not enough for full installation in very dense sand. Run the test until it reaches maximum force value. After that the load will decrease sharply. Stop penetration on manual pilot, and start again when the force drops to around 50KN. This can be repeated couple of times to reach some extra penetration. However, if the missing penetration is more than 2-3cm, it is not possible to install it fully. Stop the test and save the data for analyzing.

4.8. CPTs after installation

8 CPTs are performed after each installation. There are 4 positions outside the bucket; around 80cm from the center and as close to the bucket skirt as possible (within 5cm). CPTs inside the bucket are performed through the valves/ holes from the valves.

For performing CPT after the test the water level is lowered to be 2-5 cm above soil surface. Water is removed from the top by using a small pump, see sect. 3.4.5. The bucket model is disconnected from the piston – use beams and platform on the lower level as a working platform. The working platform should also be built up on the highest level to move the piston and attach the CPT device with extension pieces. The valves situated close to the skirt should be opened for the test. However, the valves in the middle should be removed in order to fit the CPT device inside. For the modular bucket, all 4 valves should be removed to fit the CPT device inside. Use an appropriate wrench to unfasten the valves. A pipe wrench could also come in handy.

- Do not disconnect the small pipes connected to the pore pressure transducers if the uninstallation test should be run.

The piston is moved to each position and fixed with 2 clamps. The extension piece and the CPT device must be attached to the piston. There is an extra CPT extension piece that can rotate and be fitted to the positions, as the bucket could be slightly rotated and the valves are a bit mismatch with the loading frame line.



Fig. 4.10. CPT performed with extension piece; CPT inside the valve

The length of extension piece should be selected properly, so the maximum length range of the piston is ensured for around 110 cm of CPT inside the sand – remember about an extra part from the CPT extension. The cone of CPT device should be situated just above the soil surface before the test starts, with piston being in its maximum height. Check if the CPT device is not bended and ask technicians for help with strengthening it before the test.

Keep in mind, that the installed bucket lid might be much higher than the soil surface due to the heave development. Change the extension piece for 4 positions inside the bucket, so that the test can still be performed. If bucket has not been fully installed, the CPT can still be performed on the desired 110 cm length. The CPT device should be inserted into the hole/valve after the piston is clamped in a correct position. Then fix the CPT device to the extension piece with appropriate tools. When fitting piston to the correct position is tricky, attach the CPT inserted in the hole/valve first. Two people should clamp piston on the opposite corners at the same time. Otherwise, the piston will move and CPT device become bended. In all situations, the cone of the device must be close, above the soil surface before the test starts.

The CPT is a 'displacement-control' test. The setting for the hydraulic piston must be adjusted for this mode. The settings are changed on the control switchboard and the setting switchboard for the hydraulic piston and the hydraulic motor should be closed, see sec. 3.4.1. The set-point displacement on the control switchboard should be 5 mm/s.

Zero-down the displacement and CPT resistance in 'Station Manager' (sec.3.6). Afterwards, start measurements in 'Multipurpose Elite' (sec. 3.6.). Start the test by starting the penetration with the manual pilot - 'down'. The switch on the pilot should be on the option 'slow'. The head of CPT where the cable is connected is not waterproof, so it cannot be submerged to the water. The test is finished when reaching around 110cm penetration in sand and recordings in 'Multipurpose Elite' are saved. The CPT can be moved up with a 'fast' mode on the manual pilot.

4.9. Uninstallation test

The uninstallation test of the bucket is performed as a 'displacement-control', with the same procedure as the jacking installation, but instead of downward movement of the piston, the movement is in an upward direction. See sec. 3.4.1. how to set the hydraulic motor. The 'Set-point' for displacement on the control switchboard should be 0.28 mm/s. The small load cannot be attached to the piston for this test as the force can extend the capacity of the load cell.

The CPT device should be disconnected and the bucket should be fixed again with 4 screws. It might require a change in the length of extension piece that was changed for CPT. The piston must be clamped with 4 clamps. The valves are open as it was for the jacking installation.

The bucket should be submerged before starting the test. Fill the water from the top, see sec. 4.4. Run the test in 'Multipurpose Elite', see sec. 3.6. Start the uninstallation of the bucket with manual pilot by pushing button 'up'. The switch on the pilot should be on the option 'slow'. Installation is in a final stage, when the bucket is out of sand.

4.10. Removing the bucket model

- After suction installation:

To remove the bucket the force from the piston can be joined with an extra force coming from the overpressure applied under the bucket lid – in case the force will exceed the limit given by the load cell.

The CPT device should be disconnected and the bucket should be fixed which might require a change of extension piece. The piston must be clamped with 4 clamps. Connect the pump to the middle valves, see sec. 4.3. The two remaining valves should be closed. Next, the water level should be raised up to 50cm above the soil surface. The piston can be moved up as a 'force-control' or 'displacement-control', however the load applied by the piston cannot exceed the load cell capacity of 20kN. The bucket should be removed approximately half way from sand. Next the bucket is removed by crane.

- Removing the bucket by the crane:

After uninstallation the water level should be reduced to be slightly over the sand surface. The working platform on the appropriate height should be prepared with two beams and the wooden plate. After the uninstallation test, the black beams with square cross section must be used at the lowest level of supporting brackets inside the soil container. The height below the bucket tip and the soil surface is limited, so only those beams will fit. The bucket is positioned on the platform and disconnected from the piston. The hose from suction pump and the pipes connected to the PP transducer are also disconnected.

After removing the bucket to its half-depth the working platform should be prepared to get an access to the bucket and disconnect it from the piston. The bucket will remain in the soil, but might move slightly downward .

Fix the connection piece for the crane to the bucket. One of the bolts should be long, for safety reasons. The connection should be slightly tight and not too tight, so it can be easily untighten.

Use the crane to remove the bucket from the soil container - remember about the safety rules while using the crane. The bucket should be hold with hands while slowly moving it up. The loading frame is limiting the center access for the crane; therefore, the crane

will push the bucket a bit side-way while lifting it. Be careful not to destroy the transducers on the soil container tank. Remove the bucket and place it on the wooden pallet on the floor. Clean the bucket if there is any remaining soil on the skirt. Clean the channels for measuring the pore pressure around the skirt by pushing the air through the outlets on the lid. For both use the air piston.



Fig. 4.11. Holding the bucket when lifting it; cleaning the bucket outlets with air piston

4.11. Direct measurements of soil relative density

A test for direct measurements of a relative soil density D_r should be performed after installation test. The soil close to the bucket is obviously disturb, therefore the soil sample should be collected in some distance from the bucket foundation skirt.

The sample is collected with a use of cylindrical steel molder, Fig. 4.12. The molder must be pushed vertically into the sand, with a constant speed, trying to reduce the soil disturbance as much as possible. When the entire cylinder is filled with sand, the lower part of sample is cut off from the rest of the soil by using the special cutting tool. The sample is then prepare in another lab room, by equally levelling the top and the bottom of sample that is still in the cylindrical molder. For the upper side a special levelling tool can be used, which allow to remove 2mm soil thickness from the sample. Then all sand on the outside of molder and on the top of molder must be removed by a small brush. Finally, the sample is removed from the molder by placing it in the previously weighted bowl. All sand remaining on the inside walls should be also added to this bowl with a small brush.



Fig. 4.12. Tools for the unit soil weight test: cylindrical molder, cutting tool, levelling tool, the hook for removing some sand from the molder, measurement tool and brush.

The bowl with sand is again weighted. The exact dimensions of the sample must be known to calculate the unit weight of soil.

Next the bowl is situated in the own, so the sample can dry in the temperature of 100°C for 24 hours. The sample is next put in a vacuum for a 10minutes, and after that can be weighted again, giving the dry weight of soil. The weight of wet and dry sample is used to calculate the water content.

The in-situ void ratio can be calculated from Eq.(1).

$$e_{insitu,1} = (1 + w) \cdot \frac{\rho_s}{\gamma} \cdot \gamma_w - 1 \quad (1)$$

The relative soil density is calculated with Eq.(2).

$$D_R = \frac{e_{max} - e_{in-situ}}{e_{max} - e_{min}} \quad (2)$$

The sample is taken from the height approx. 100mm below soil surface. This height should be measured while taking the sample, so it can be later on compare with results of D_r from CPT. The water level should be reduced, what improves the work effectiveness. However, it is easier to push the ring into the sand if it is more saturated. Therefore, the water should be reduced to the level of approx. 100mm below soil surface only. The appropriate hole for the depth of approx. 100mm is first prepared. The cylindrical molder is pushed into sand, see Fig. 4.13. Finally, the remaining half of hole should be still deepening, until reaching the lower edge of molder. Use cutting tool to remove the sample.



Fig. 4.13. Taking out the sample for D_R direct measurement

5. References

- Borup, M., and Hedegaard, J. 1995. *Baskarp Sand No. 15: data report 9403*. Data Report, Aalborg University: Geotechnical Engineering Group, Aalborg.
- Ibsen, L.B., Hanson, M., Hjort, T., and Thaarup, M. 2009. *MC-Parameter Calibration for Baskarp Sand No.15*. DCE Technical report 62, Aalborg University: Department of Civil Engineering, Aalborg.
- Koteras, A.K. 2017. *Set-up and Test Procedure for Suction Installation and Uninstallation of Bucket Foundation*. DCE Technical Memorandum 63, Aalborg University: Department of Civil Engineering, Aalborg.
- Thomassen, K. 2015. *Test Procedure for Axially Loaded Piles in Sand*. DCE Technical report 196, Aalborg University: Department of Civil Engineering, Aalborg.
- Vaitkunaite, E. 2015. *Test procedure for Axially Loaded Bucket Foundations in Sand, Large Yellow Box*. DCE Technical Memorandum 51, Aalborg University: Department of Civil Engineering, Aalborg.
- Vaitkunaite, E., Thomassen, K., Borup, K., and Nielsen, B.N. 2015. *Safety Instructions in the AAU Geotechnical Laboratory: (Large Yellow Box)*. DCE Technical report 197, Aalborg University: Department of Civil Engineering, Aalborg.

Recent publications in the DCE Technical Memorandum Series

