



AALBORG UNIVERSITY
DENMARK

Aalborg Universitet

Small-Signal Model of STATCOM and Its Model Validation

Gong, Hong; Wang, Xiongfei; Yang, Dongsheng

Published in:

Proceedings of the 2018 IEEE Power & Energy Society General Meeting (PESGM)

DOI (link to publication from Publisher):

[10.1109/PESGM.2018.8586130](https://doi.org/10.1109/PESGM.2018.8586130)

Publication date:

2018

Document Version

Accepted author manuscript, peer reviewed version

[Link to publication from Aalborg University](#)

Citation for published version (APA):

Gong, H., Wang, X., & Yang, D. (2018). Small-Signal Model of STATCOM and Its Model Validation. In *Proceedings of the 2018 IEEE Power & Energy Society General Meeting (PESGM)* (pp. 1-5). [18PESGM1690] IEEE Press. IEEE Power and Energy Society General Meeting <https://doi.org/10.1109/PESGM.2018.8586130>

General rights

Copyright and moral rights for the publications made accessible in the public portal are retained by the authors and/or other copyright owners and it is a condition of accessing publications that users recognise and abide by the legal requirements associated with these rights.

- ? Users may download and print one copy of any publication from the public portal for the purpose of private study or research.
- ? You may not further distribute the material or use it for any profit-making activity or commercial gain
- ? You may freely distribute the URL identifying the publication in the public portal ?

Take down policy

If you believe that this document breaches copyright please contact us at vbn@aub.aau.dk providing details, and we will remove access to the work immediately and investigate your claim.

Small-Signal Model of STATCOM and Its Model Validation

Hong Gong, Xiongfei Wang and Dongsheng Yang
Department of Energy Technology
Aalborg University
Aalborg, Denmark
hgo@et.aau.dk, doy@et.aau.dk, xwa@et.aau.dk

Abstract— This paper proposes a small-signal model of STATCOM based on theoretical derivation. This theoretical model is obtained by linearization of the dc-link control loop, Phase-Locked Loop (PLL), ac voltage control loop under the weak grid condition. In order to validate the correctness of this small-signal model, an identified model in the form of transfer function matrix is obtained by Output Error with Extended Prediction Model (OEEPM) identification method using the data acquired from the nonlinear time-domain simulation. The two developed models are compared using the time-domain simulations conducted in MATLAB/Simulink. Based on the compared results disturbance, the accuracy and applicability of the proposed small-signal model have been discussed.

Keywords—Small-signal model, STATCOM, parametric identification, model validation

I. INTRODUCTION

In recent years, there has been a continuous increase in the installed wind power generation capacity throughout the world. In order to improve the voltage stability of wind power systems, static synchronous compensator (STATCOM) has been widely applied in large-scale wind power systems [1], [2]. However, STATCOM based on power inverters tend to cause instability in a wide frequency due to the interactions between the multi-time scale control behavior of inverters and the large grid impedance [3], [4].

In the case of three-phase ac systems, there does not exist dc operation point. The small-signal impedance model has been developed in the rotating dq -frame to analyze the dynamic characterization and stability of grid-connected inverter systems [5], [6]. However, before calculating the small-signal impedance model for stability analysis, an accurate small-signal model must be guaranteed.

When adopting the ac voltage controller, STATCOM is usually applied to regulate the voltage at the point of common coupling (PCC) where the converter of STATCOM is synchronized with through phase-locked loop (PLL). Since the grid voltage is usually assumed to be stiff, and the PCC bus voltage is also strongly associated with the grid impedance. Hence, it is very important to include the grid impedance in the small-signal model of STATCOM. In other words, the grid impedance and AC voltage control loop have a significant impact on the stability of STATCOM. On the other hand, dc-link voltage controller that guarantees the normal operation of STATCOM is also a pretty crucial issue

for stability analysis. Therefore, when establishing the small-signal model of STATCOM by linearization, the influence of dc-link voltage controller, PLL, ac voltage controller and grid impedance should all be considered, which could help to obtain a more accurate small-signal impedance model.

However, because of the complexity of the theoretical modeling and simplicity of derivation process, the accuracy of this small-signal model could not be guaranteed. An identified model would be proposed to validate the correctness of this theoretical model. The existing power electronics inverter was used to generate the input (excitation signal) of the identified system through the pulse width modulator (PWM) and the cross-correlation method was applied to extract the response of this identified system [10], [11]. According to the DFT analysis of the system response to the impulse input signals, the response of the system could be extracted online with the help of DSP [12]. However, the identification methods mentioned before are carried out by non-parametric methods which cannot be applied for controller design directly. This paper adopts a parametric method to obtain the model which can be used to validate the correctness of the parameter-based small-signal model derived through theoretical expression.

In this paper, the authors present a small-signal model of STATCOM based on theoretical derivation. For this theoretical derivation model, the effects of PLL, dc-link voltage controller, ac voltage controller as well as the grid impedance in the weak grid condition are also included in the small-signal model. In order to validate the accuracy of this small-signal model, an identified model is obtained by the nonlinear time domain simulation which takes accounts of all the control aspects. Based on the validated model, the small-signal impedance model is able to be obtained and could be applied for stability analysis and controller design.

II. SMALL-SIGNAL MODEL OF STATCOM

Fig.1 shows the schematics of the STATCOM. L and R are filtered inductor and its parasitic resistor. i_{abc} and u_{abc} represent the current of STATCOM and PCC voltage, respectively. U_{inv} means the output voltage of the inverter. U_{dc} is the DC-Link voltage of STATCOM.

There are three dq -frames defined in Fig.2. One is the system dq -frame whose d -axis is aligned with the grid voltage U_g which can be considered as stiff, and another one

called the PCC dq -frame whose d -axis is aligned with PCC bus voltage U_s ; the third one named the controller dq -frame which is defined by the PLL. In the steady state, the controller dq -frame is the same as the PCC dq -frame. When small-signal perturbations are added to the PCC voltage, there is an angle difference $\Delta\theta + \theta$ between the controller and system dq -frames. As illustrated by Fig.2, these two frames with the controller one (superscript “c”) and the system one (superscript “g”) aligned with U_g .

According to Fig.2 and linearizing the PLL, the transfer relationship between the vectors in the system frame and the vectors in the controller frames can be represented by three asymmetric transfer matrices, which are given by

$$\begin{aligned}\Delta \mathbf{U}_{sdq}^c &= \mathbf{G}_{PLL}^v \Delta \mathbf{U}_{sdq}^g \\ \Delta \mathbf{I}_{sdq}^c &= \mathbf{G}_{PLL}^i \Delta \mathbf{U}_{sdq}^g + \mathbf{T} \Delta \mathbf{I}_{sdq}^g \\ \Delta \mathbf{D}_{sdq}^g &= \mathbf{G}_{PLL}^D \Delta \mathbf{U}_{sdq}^g + \mathbf{T}_1 \Delta \mathbf{D}_{sdq}^c\end{aligned}\quad (1)$$

where \mathbf{G}_{PLL}^v is the transfer function matrix from the PCC voltage in the system dq -frame to the PCC voltage in the controller frame. \mathbf{G}_{PLL}^i is the transfer function matrix from \mathbf{U}_{sdq}^g to the injected current in the controller frame. \mathbf{G}_{PLL}^D is the transfer function matrix from \mathbf{U}_{sdq}^g to the transfer matrix of duty cycle \mathbf{D}_{sdq}^g . \mathbf{T} is the transfer matrix between the PCC dq -frame (or controller frame) and the system frame; \mathbf{T}_1 is its inverse matrix.

In general, STATCOM would be applied to regulate the PCC voltage while dc-link voltage control dynamics are associated with active power. Hence, equations related to ac voltage U_s and dc voltage U_{dc} control dynamics are

$$\Delta U_s = \mathbf{H}_1 \mathbf{G}_{PLL}^v \Delta \mathbf{U}_{sdq}^g \quad (2)$$

$$\Delta U_{dc} = \frac{3}{2U_{dc0} C S} (\mathbf{H}_2 \Delta \mathbf{I}_{sdq}^g + \mathbf{H}_3 \Delta \mathbf{U}_{sdq}^g) \quad (3)$$

$$\Delta I_q^* = -\Delta U_s G_{ac}; \quad \Delta I_d^* = (\Delta U_{dc ref} - \Delta U_{dc}) G_{dc} \quad (4)$$

where

$$\mathbf{H}_1 = \begin{bmatrix} \frac{U_{sd0}^c}{U_{s0}} & \frac{U_{sq0}^c}{U_{s0}} \\ \frac{U_{sd0}^g}{U_{s0}} & \frac{U_{sq0}^g}{U_{s0}} \end{bmatrix}, \mathbf{H}_2 = \begin{bmatrix} U_{sd0}^g & U_{sq0}^g \end{bmatrix}, \mathbf{H}_3 = \begin{bmatrix} I_{sd0}^g & I_{sq0}^g \end{bmatrix}$$

subscript “0” represents the steady values of its corresponding variables. G_{ac} and G_{dc} represent the AC voltage and dc-link voltage controller, which in general are PI controllers. ΔI_{sd}^* and ΔI_{sq}^* are the perturbations of active and reactive current references, respectively. $\Delta U_{dc ref}$ is the perturbation of the DC-Link voltage reference, which would be implemented as the input of small-signal perturbation for identification.

In the previous research about small-signal model of inverters, the PCC voltage is considered to be constant. This

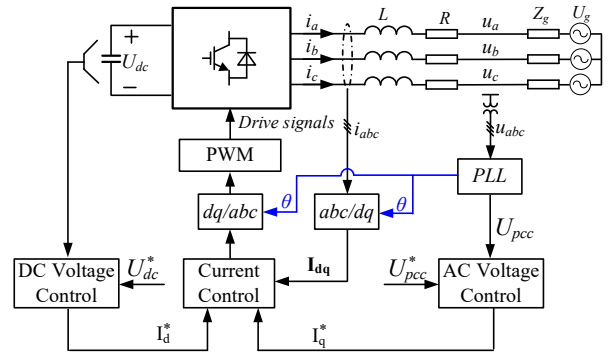

Fig. Equivalent circuit diagram of STATCOM.

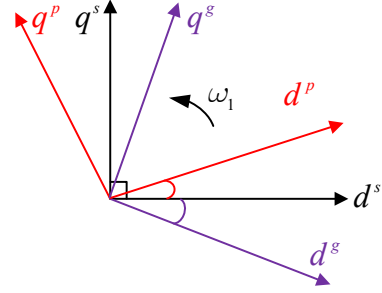

Fig.2. Controller, PCC and system dq -frames.

hypothesis cannot be applied to the derivation of small-signal of STATCOM since it regulates the PCC voltage dynamically. In this paper, the grid voltage is assumed stiff so the grid impedance and AC voltage controller would cause small-signal perturbation of STATCOM to be more coupled. Therefore, the relationship among grid voltage \mathbf{U}_{gdq}^g , output voltage of STATCOM \mathbf{U}_{sdq}^g , inverter output voltage \mathbf{U}_{invdq}^g , output current of STATCOM \mathbf{I}_{sdq}^g could be obtained

$$\Delta \mathbf{U}_{invdq}^g + \mathbf{Z} \mathbf{Z}_g^{-1} \Delta \mathbf{U}_{gdq}^g = (\mathbf{I} + \mathbf{Z} \mathbf{Z}_g^{-1} + \mathbf{Z} \mathbf{Z}_l^{-1}) \Delta \mathbf{U}_{sdq}^g \quad (5)$$

$$\Delta \mathbf{U}_{gdq}^g - (\mathbf{I} + \mathbf{Z}_g \mathbf{Z}_l^{-1}) \Delta \mathbf{U}_{invdq}^g = (\mathbf{Z}_g + \mathbf{Z}_g \mathbf{Z}_l^{-1} + \mathbf{Z}) \Delta \mathbf{I}_{sdq}^g \quad (6)$$

Based on the control block, the output voltage of inverter could be derived

$$\Delta \mathbf{U}_{invdq}^g = \mathbf{G}_{dvv} \Delta \mathbf{D}_{sdq}^c = \mathbf{G}_{dvv} \mathbf{G}_i (\Delta \mathbf{I}_{sdq}^c - \Delta \mathbf{I}_{dq}^*) \quad (7)$$

where \mathbf{G}_{dvv} represents the transfer function matrix between the duty-ratio vector and output voltage vector; and \mathbf{G}_i is transfer function matrix of the current controller (generally the PI controller).

By rearranging above equations, the small-signal model could be derived in the form of the transfer function, as shown in Fig.3. In the Fig. 3, the inputs of the small-signal model are the dc-link voltage reference and grid voltages in the dq -domain. The outputs of the small-signal model are the DC-Link voltage and output currents of STATCOM in the dq -domain. $G_{dc}(s)$ is the closed loop transfer function from the voltage reference to dc-link voltage. $\mathbf{Y}_o(s)$ is output

impedance of the STATCOM seen at PCC. $\mathbf{G}_{cs1}(s)$ and $\mathbf{G}_{cs2}(s)$ are the cross-coupling terms between the dc-link voltage control and the current control.

However, since the grid voltage is assumed stiff in this paper (which means $\Delta U_{gdq}^s = \mathbf{0}$), the transfer function matrix $\mathbf{Y}_o(s)$ and transfer function matrix $\mathbf{G}_{cs2}(s)$ would not be considered. The expression of $G_{dc}(s)$ and $\mathbf{G}_{cs1}(s)$ could be obtained

$$G_{dc} = \frac{3}{2U_{dc0}C_S} [\mathbf{H}_2 \mathbf{M}_{211} (\mathbf{Z}_g \mathbf{Z}_l^{-1} \mathbf{M}_{210} + \mathbf{M}_{210}) + \mathbf{H}_3 (\mathbf{I} + \mathbf{Z}\mathbf{Z}_g^{-1} + \mathbf{Z}\mathbf{Z}_l^{-1} - \mathbf{M}_8)^{-1} \mathbf{M}_{10}] \begin{bmatrix} 1 \\ 0 \end{bmatrix} \quad (8)$$

$$\mathbf{G}_{cs1}(s) = \mathbf{M}_{211} (\mathbf{Z}_g \mathbf{Z}_l^{-1} \mathbf{M}_{210} + \mathbf{M}_{210}) \begin{bmatrix} 1 \\ 0 \end{bmatrix} \quad (9)$$

Therefore, the small-signal model of STATCOM could be expressed in (8) and (9). In order to express the small-signal model simply, the calculation transfer matrixes (\mathbf{M}_1 - \mathbf{M}_{211}) are introduced and the detailed expressions could be found in the appendix.

III. IDENTIFIED MODEL OF STATCOM

Although the small-signal model of STATCOM can be derived based on theoretical expression, the accuracy of this model could not be guaranteed because of its simplicity of derivation process. Therefore, an identified model of STATCOM is proposed by measuring the transfer function from STATCOM, which can be used for model validation for the analytical small-signal model derived before.

The identification method is usually used to identify the plant model. As can be seen in Fig.4, $G_c(s)$, $G_{plant}(s)$ and $G_f(s)$ represent controller transfer function, plant transfer function (physical system) and feedback transfer function, respectively. The system consisting of $G_c(s)$, $G_{plant}(s)$ and $G_f(s)$ can be replaced by $G(s)$. Therefore, the open loop identification method could be applied to identify the model of STATCOM directly.

The transfer function as shown in Fig.4 is able to obtain through the identification method using the data acquired from the simulation model. The Fig.5 shows the flowchart of the identification procedure of STATCOM.

A. Generation of Excitation Signals

PRBS are sequences of rectangular pluses, which approximate a discrete-time white noise and thus have a spectral concern rich in frequency, as shown in Fig.6. To obtain the response over the entire frequency spectrum generated by a particular PRBS, the test time t_t should be larger than at least one period of PRBS. Besides, the maximum duration of a pulse of PRBS would influence the accuracy of identified model's steady gain, which is mainly because the excitation signal should assure at least one completed dynamic response of the system before the next excitation signal comes. In this paper, the excitation signals (PRBS) would add to the DC-Link voltage reference and the response of the system (STATCOM) would be acquired by the scope of the simulation model.

B. Signal Processing

In order to obtain the accurate model, the output/input data acquired from simulation or measurements must be centered, which means the measured values have to subtract the mean values before the identification starts. Besides, either the DC components or the slow drift of the operating point during identification have to be eliminated.

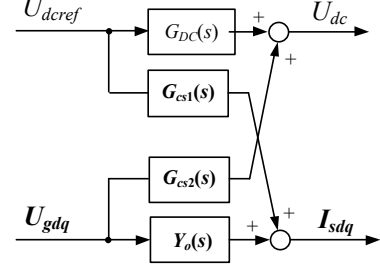

Fig.3. Small-signal model of STATCOM.

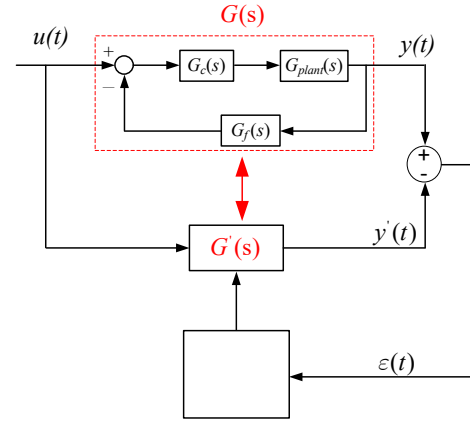

Fig.4. Simplification of the closed-loop transfer function.

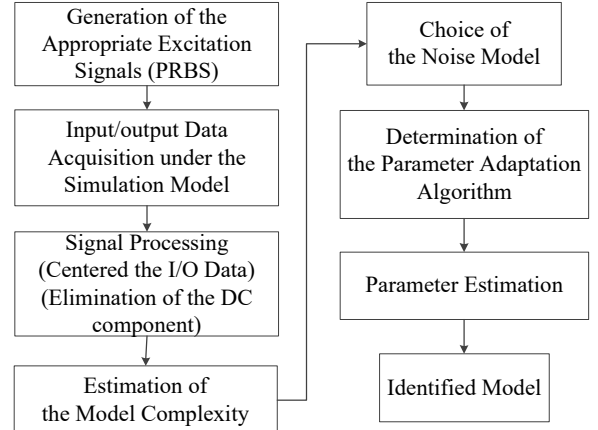

Fig.5. Flowchart of the identification procedure of a transfer function model.

C. Selection of the Model Complexity and Noise Model

In fact, the estimation of the model complexity means the selection of the degrees of the numerator and denominator of the transfer function. According to the chosen form of disturbance model, there are four main forms (which can be found in [7]) of identified model structures which would pose significant influence on the identification of small-signal model. The specific degree of the identified model would not elaborated in this paper since the limited space.

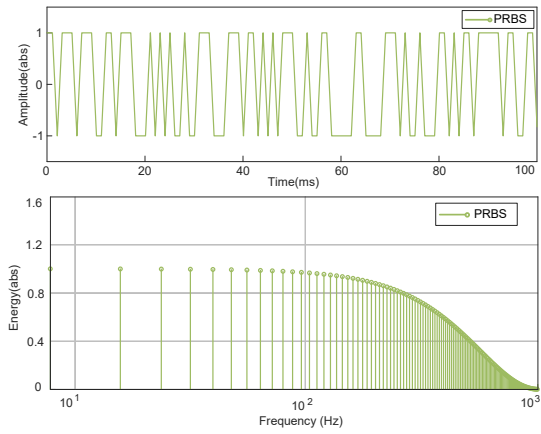

Fig.6. Samples of PRBS in time domain and its power spectra

D. Identification Algorithm

Based on the chosen noise model, the corresponding parameter adaptation algorithm would be determined. Basically, there are two types of identification methods: one based on the whitening of the prediction error (type I), the other one based on the correlation of the observation vector and the prediction error (type II). In this paper, Output Error with Extended Prediction Model identification method (type I) is adopted to estimate the parameters of the identified model since it has faster bias rejection compared to other methods [7].

Eventually, the identified model could be obtained based on parameter estimation and could be applied to validate the correctness of the small-signal model obtained by theoretical derivation.

IV. VALIDATION AND COMPARISON

The responses of the system acquired from the small-signal model obtained from the theoretical derivation and the identified model are compared in the time domain. These two small-signal transfer models were built in MATLAB/Simulink. And for simplicity, only the step change of the reference of the DC-Link voltage is introduced to verify the small-signal model. The parameters of STATCOM for theoretical model and identified model are shown in Table I.

TABLE I. PARAMETERS OF STATCOM

Symbol	Description	Value
K_{dc_p}/K_{dc_i}	DC voltage outer controller	0.5/5
K_{i_p}/K_{i_i}	Current inner controller	0.02/25
K_{PLL_p}/K_{PLL_i}	PI controller of PLL	0.28/3
ω	Grid frequency	314 rad/s
f_s	Sampling frequency	10kHz
I_{sd0}	d channel current steady value	2A
I_{sq0}	q channel current steady value	20A
C	Capacitor of STATCOM	10000 μ F
U_{dc0}	DC voltage of STATCOM	730V
U_g	Grid phase-neutral peak voltage	325V
L	Filtered inductor	3mH
R	Filtered resistor	0.2 Ω
L_g	Grid inductor	10mH
R_g	Grid resistor	0.2 Ω

Fig.7, Fig.8 and Fig.9 show the perturbation components of the dc-link voltage and dq axis current, respectively. In Fig.7, when the reference of the DC-Link voltage (the input of the small-signal model) increases by 10V (1.1% of the nominal reference), the responses of the DC-Link voltage calculated from the theoretical small-signal model and acquired from identified model match well in large extent.

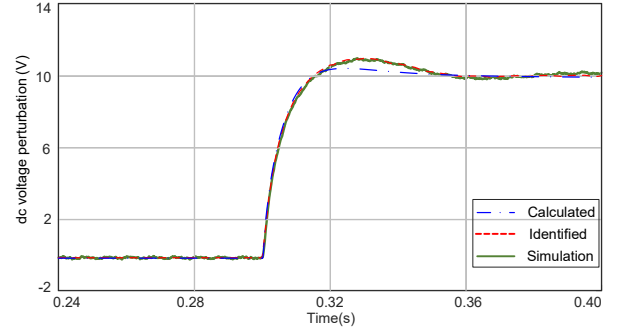

Fig.7. Perturbation components of the dc-link voltage.

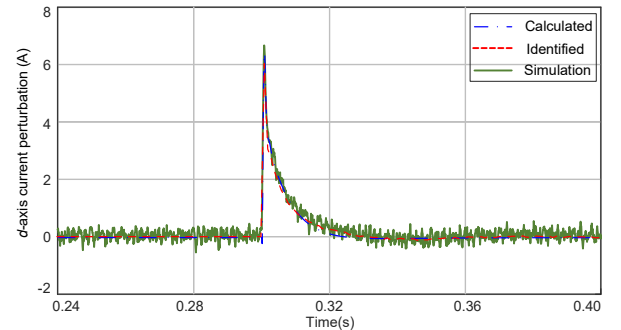

Fig.8. Perturbation components of the d-axis current.

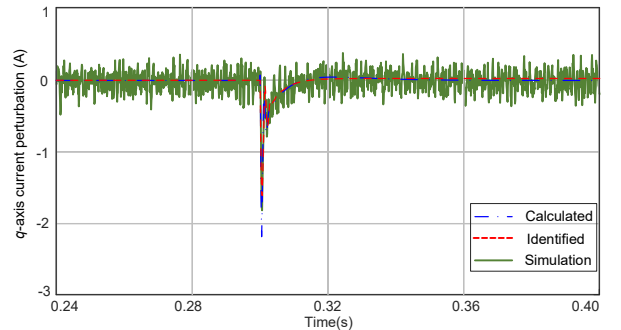

Fig.9. Perturbation components of the q-axis current.

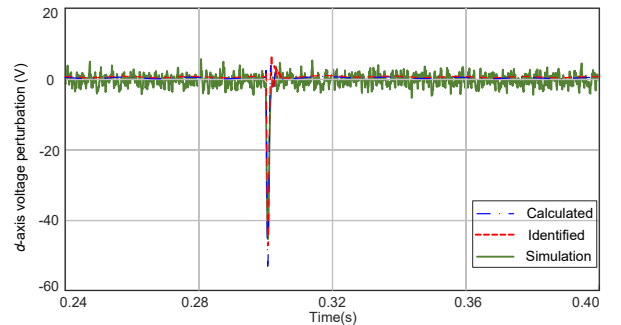

Fig.10. Perturbation components of d-axis voltage.

However, there still exist minor mismatches between the responses of the DC-Link voltage obtained from the identified model and calculated from theoretical derivation.

This is mainly because the linearization of the active power associated with DC-Link voltage has ignored the nonlinear multiplied term of the expression which would lead to little difference of the DC side model.

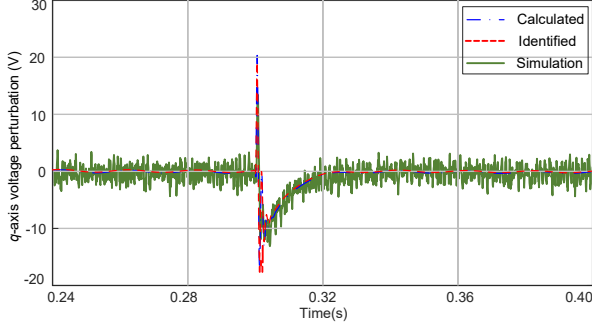

Fig.11. Perturbation components of the q-axis voltage.

Besides, the results of dq axis current obtained from the identified model and theoretical calculation are perfectly consistent, which means the small-signal model in the AC side could represent the dynamic characteristic of STATCOM completely.

On the other hand, based on the theoretical small-signal model, the responses of the output voltage of STATCOM could also be calculated, as shown in Fig.9 and Fig.10. As can be seen, the results obtained from theoretical model and identified model also have the same dynamic characteristic. This means that based on the response of the output voltage and current of STATCOM, the small-signal impedance model of STATCOM could be calculated accurately. Furthermore, the calculated small-signal impedance model could be used to analyze the interaction stability between STATCOM and external AC systems.

V. CONCLUSION

Based on the theoretical derivation, a small-signal model of STATCOM have been presented in this paper. In order to derive the small-signal model of STATCOM more accurately through physical circuit, the influence of the grid impedance, PLL, DC-Link voltage controller and AC voltage controller has been considered. According to the simulation data, the identified model could be obtained to validate the accuracy of the proposed small-signal model of STATCOM derived from the theoretical expression. Since the ignorance of the nonlinear multiplied term, the theoretical model shows minor difference with the identified model in the DC side while it would not have a significant influence on the interaction stability analysis. Moreover, in the AC side, the theoretical model matches very well with the identified model, which means an accurate small-signal impedance model could be calculated based on the proposed small-signal model and applied for interaction stability analysis with external AC grids.

APPENDIX

The detailed expressions of the calculation transfer matrixes (\mathbf{M}_1 - \mathbf{M}_{211}) are

$$\left\{ \begin{array}{l} \mathbf{M}_1 = \mathbf{T}_1 \mathbf{G}_i \mathbf{G}_{PLL}^i - \mathbf{G}_{PLL}^D \\ \mathbf{M}_2 = \mathbf{T}_1 \mathbf{G}_i \mathbf{T} \\ \mathbf{M}_3 = \mathbf{T}_1 \mathbf{G}_i \mathbf{G}_{dac} \\ \mathbf{M}_4 = \mathbf{M}_1 - \mathbf{T}_1 \mathbf{G}_i \mathbf{H}_3 \\ \mathbf{M}_5 = \mathbf{M}_2 - \mathbf{T}_1 \mathbf{G}_i \mathbf{H}_2 \\ \mathbf{M}_6 = (\mathbf{Z}_g + \mathbf{Z}_g \mathbf{Z} \mathbf{Z}_l^{-1} + \mathbf{Z})^{-1} \\ \mathbf{M}_7 = \mathbf{M}_6 (\mathbf{Z}_g \mathbf{Z}_l^{-1} + \mathbf{I})^{-1} \\ \mathbf{M}_8 = (\mathbf{I} + \mathbf{G}_{dvv} \mathbf{M}_5 \mathbf{M}_7)^{-1} \mathbf{G}_{dvv} \mathbf{M}_4 \\ \mathbf{M}_9 = (\mathbf{I} + \mathbf{G}_{dvv} \mathbf{M}_5 \mathbf{M}_7)^{-1} \mathbf{G}_{dvv} \mathbf{M}_5 \mathbf{M}_6 \\ \mathbf{M}_{10} = (\mathbf{I} + \mathbf{G}_{dvv} \mathbf{M}_5 \mathbf{M}_7)^{-1} \mathbf{G}_{dvv} \mathbf{M}_3 \\ \mathbf{M}_{26} = (\mathbf{I} + \mathbf{Z} \mathbf{Z}_g^{-1} + \mathbf{Z} \mathbf{Z}_l^{-1})^{-1} \\ \mathbf{M}_{27} = \mathbf{M}_{26} \mathbf{Z} \mathbf{Z}_g^{-1} \\ \mathbf{M}_{28} = (\mathbf{I} - \mathbf{G}_{dvv} \mathbf{M}_4 \mathbf{M}_{26})^{-1} \mathbf{G}_{dvv} \mathbf{M}_4 \mathbf{M}_{27} \\ \mathbf{M}_{29} = (\mathbf{I} - \mathbf{G}_{dvv} \mathbf{M}_4 \mathbf{M}_{26})^{-1} \mathbf{G}_{dvv} \mathbf{M}_5 \\ \mathbf{M}_{210} = (\mathbf{I} - \mathbf{G}_{dvv} \mathbf{M}_4 \mathbf{M}_{26})^{-1} \mathbf{G}_{dvv} \mathbf{M}_3 \\ \mathbf{M}_{211} = (\mathbf{Z}_g + \mathbf{Z}_g \mathbf{Z} \mathbf{Z}_l^{-1} + \mathbf{Z} + \mathbf{Z}_g \mathbf{Z}_l^{-1} \mathbf{M}_{29} + \mathbf{M}_{29})^{-1} \end{array} \right.$$

where $\mathbf{I} = \begin{bmatrix} 1 & 0 \\ 0 & 1 \end{bmatrix}$, $\mathbf{G}_i = \begin{bmatrix} G_i & 0 \\ 0 & G_i \end{bmatrix}$, $\mathbf{G}_{dac} = \begin{bmatrix} G_{dc} & 0 \\ 0 & G_{ac} \end{bmatrix}$

REFERENCES

- [1] F. Blaabjerg, R. Teodorescu, M. Liserre and A. V. Timbus, "Overview of Control and Grid Synchronization for Distributed Power Generation Systems", *IEEE Trans. Ind. Electron.*, vol. 53, no. 5, pp. 1398-1409, Oct. 2006.
- [2] Z. Chen, F. Blaabjerg and Y. Hu, "Stability Improvement of Wind Turbine Systems by STATCOM", in *IECON 2006, Oct., 2006*, pp. 4213-4218, 2006.
- [3] X. Wang, L. Harnefors and F. Blaabjerg, "A Unified Impedance Model of Grid-Connected Voltage-Source Converters", *IEEE Trans. Power Electron.*, vol. PP, no. 99, pp. 1-1, 2017.
- [4] C. Li, R. Burgos, Y. Tang and D. Boroyevich, "Impedance-based stability analysis of multiple STATCOMs in proximity", in *Proc. 17th Workshop on Control and Modeling for Power Electronics (COMPEL)*, June, 2016 pp. 1-6.
- [5] X. Wang, F. Blaabjerg and W. Wu, "Modeling and Analysis of Harmonic Stability in an AC Power-Electronics-Based Power System", *IEEE Trans. Power Electron.*, vol. 29, no. 12, pp. 6421-6432, 2014.
- [6] J. Sun, "Small-Signal Methods for AC Distributed Power Systems-A Review", *IEEE Trans. Power Electron.*, vol. 24, no. 11, pp. 2545-2554, 2009.
- [7] L. Ioan Doré, and G. Zito, "Digital control systems: design, identification and implementation", *Springer Science & Business Media*, pp. 230-231, 2005.
- [8] D. Martin, I. Nam, J. Siegers and E. Santi, "Wide bandwidth three-phase impedance identification using existing power electronics inverter", in *Proc. Appl. Power Electron. Conf. Expo.*, Mar. 2013, pp. 334-341.
- [9] S. Neshvad, S. Chatzinotas and J. Sachau, "Wideband Identification of Power Network Parameters Using Pseudo-Random Binary Sequences on Power Inverters", *IEEE Trans. Smart Grid*, vol. 6, no. 5, pp. 2293-2301, Sept. 2015.
- [10] T. Roinila, T. Messo and E. Santi, "MIMO-Identification Techniques for Rapid Impedance-based Stability Assessment of Three Phase Systems in D-Q Domain", *IEEE Trans. Ind. Electron.*, vol. PP, no. 99, pp. 1-1.