



Aalborg Universitet

AALBORG UNIVERSITY  
DENMARK

## Performance evaluation of multi-antenna receivers for vehicular communications in live LTE networks

Izydorczyk, Tomasz; Tavares, Fernando Menezes Leitão; Berardinelli, Gilberto; Bucur, Madalina Cristina; Mogensen, Preben

*Published in:*  
2019 IEEE 89th Vehicular Technology Conference (VTC2019-Spring)

*DOI (link to publication from Publisher):*  
[10.1109/VTCSpring.2019.8746609](https://doi.org/10.1109/VTCSpring.2019.8746609)

*Publication date:*  
2019

*Document Version*  
Accepted author manuscript, peer reviewed version

[Link to publication from Aalborg University](#)

*Citation for published version (APA):*  
Izydorczyk, T., Tavares, F. M. L., Berardinelli, G., Bucur, M. C., & Mogensen, P. (2019). Performance evaluation of multi-antenna receivers for vehicular communications in live LTE networks. In *2019 IEEE 89th Vehicular Technology Conference (VTC2019-Spring)* [8746609] IEEE. I E E V T S Vehicular Technology Conference. Proceedings <https://doi.org/10.1109/VTCSpring.2019.8746609>

### General rights

Copyright and moral rights for the publications made accessible in the public portal are retained by the authors and/or other copyright owners and it is a condition of accessing publications that users recognise and abide by the legal requirements associated with these rights.

- ? Users may download and print one copy of any publication from the public portal for the purpose of private study or research.
- ? You may not further distribute the material or use it for any profit-making activity or commercial gain
- ? You may freely distribute the URL identifying the publication in the public portal ?

### Take down policy

If you believe that this document breaches copyright please contact us at [vbn@aub.aau.dk](mailto:vbn@aub.aau.dk) providing details, and we will remove access to the work immediately and investigate your claim.

# Performance evaluation of multi-antenna receivers for vehicular communications in live LTE networks

Tomasz Izydorczyk<sup>\*</sup>, Fernando M. L. Tavares<sup>\*</sup>, Gilberto Berardinelli<sup>\*</sup>, Mădălina Bucur<sup>\*</sup> and Preben Mogensen<sup>\*†</sup>

<sup>\*</sup>Department of Electronic Systems, Aalborg University (AAU), Denmark

<sup>†</sup>Nokia Bell Labs, Aalborg, Denmark

E-mail: {ti, ft, gb, mcb, pm}@es.aau.dk

**Abstract**—Cellular Vehicle to Everything (C-V2X) communications with its safety and infotainment services will require a high performance receivers to cope with challenging throughput, latency and reliability requirements. With increasing levels of interference due to cell densification and introduction of the roadside units, single antenna receivers may not be able to provide the required quality of service. In this work we experimentally study the performance of multi antenna receivers based on more than 150 km of data recorded during experiments using a customized software defined radio testbed. The performance of sixteen antennas Maximum Ratio Combiner (MRC) is compared with the receive beamforming technique for the live cellular signals in the 1.8 GHz band. This study is followed by an analysis of the impact of interference and measurement environment on the receiver's performance. The results show that receive beamforming can outperform MRC in low-interfered scenarios with high Line of Sight (LoS) probability, like highways or rural areas, while ensuring comparable performance even in dense urban scenarios where LoS communication cannot be guaranteed.

## I. INTRODUCTION

Cellular Vehicle to Everything (C-V2X) communications will enable new variety of services leading to safer vehicle transportation. It is usually composed of two different communication modes. Vehicle to Vehicle (V2V) communications will provide the driver with the sensor information available in the surrounding vehicles enhancing the road awareness and leading to faster reaction in unexpected situations. On the other hand, Vehicle to Infrastructure (V2I) communications will be used to provide high bit rate infotainment content as well as sensor information from distant vehicles. According to [1], connected vehicles will create up to 700 Mbps average downlink throughput per single vehicle.

Cellular networks (especially Long Term Evolution (LTE) and upcoming 5<sup>th</sup> Generation (5G)) are expected to cope with challenging throughput, latency and reliability requirements [2] and ensure C-V2X connectivity. The current standardization work [3], [4] focuses mostly on the sidelink (V2V) aspects (especially the out of coverage scenarios) as it is assumed that 5G with techniques like Network Slicing, Edge Computing and Content Caching [5] will provide the expected data rates and meet the latency requirements imposed on the V2I communications.

However the scalability of the V2I communications is still an open issue. With the amount of cars on today's roads, the network load can become a potential bottleneck of vehicular

communications. Cell densification by means of small cells or Roadside Units (RSU) are expected to serve the increased number of vehicles at the expense of increased interference levels and latency-harming handovers.

From the vehicle manufacturers perspective, ensuring the best possible connectivity for the newly produced vehicles is a main objective. As noted in [6], the increased number of antennas installed on a vehicle should lead to higher Signal to Noise and Interference Ratio (SINR) and therefore higher throughput and lower number of retransmissions. In this way car vendors can compete among themselves to provide better quality of services or add new features due to enhanced throughput and reduced latency.

Nowadays C-V2X tests are usually conducted using vehicles equipped with a LTE modem capable of 2x2 Multiple Input Multiple Output (MIMO) transmission [7]. The authors in [8], discuss the challenges of mounting larger antenna arrays on the vehicles. However, their objectives are mostly referred towards V2V communications disregarding V2I mode as similar to a typical User Equipment (UE). It is expected that certain types of cars (trucks, buses or large industrial vehicles) are less space constrained and therefore installation of large antenna arrays will become possible.

In this work we investigate the potential of using a large antenna array on the vehicle terminal based on experimental measurements from live LTE networks using a Software Defined Radio (SDR) measurement system. We study the performance of receive beamforming and Maximum Ratio Combining (MRC) techniques for SINR improvement over a single antenna receiver in the real scenarios, as the vehicle would experience in a currently deployed networks. Rural, suburban, dense urban and highway scenarios are of interest in this study. We further investigate the impact of the measuring environment (interference distribution and characteristics of the measured scenario) on the performance of both receiver types. For the best of our knowledge, it is the first experimental study related to the benefits of using multiple antenna techniques for the V2I communications, as previous works focus either on experimental vehicular channel characterization [9],[10] or simulation assessment of receive beamforming [11] or combining [6] techniques.

The rest of the paper is structured as follows: Section II describes the measurement equipment and conducted campaign.

It is followed by the description of post-processing methods presented in Section III. Starting from Section IV-A first the performance of multiple antenna techniques in different scenarios is studied followed by a more detailed analysis of the impact of interference on the observed performance in Section IV-B. The work is concluded in Section V.

## II. MEASUREMENT METHODOLOGY

### A. Measurement equipment

In this work we use the measurement setup thoroughly described in [12] or [13] and shown on Figure 1. It is composed of sixteen antennas uniform circular array manufactured for 1.8 GHz LTE band 3 and connected to the measurement system built based on Universal Software Radio Peripheral (USRP) boards. In total eight boards are used as each board contains two independent transceiver ports. Additional ninth board is used for calibration procedure. Synchronization signal is distributed by Timing Module via Octoclocks to all boards such that after offline calibration there is a tight synchronization between all boards. The setup is used to record raw I and Q samples of LTE signal. In this way, different receiver types can be evaluated with the same portions of data during an offline processing as described later.

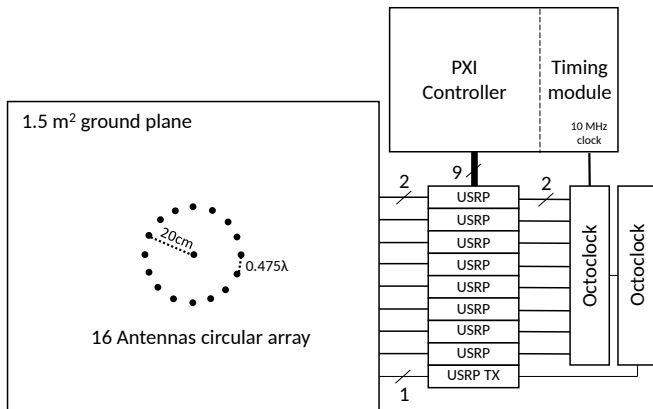

Fig. 1. Schematic of the measurement setup

The assembled setup was placed inside a van, while antennas (sixteen monopoles) were manufactured on a 1.5 m<sup>2</sup> ground plane installed on top of the van as shown on Figure 2. In order to enhance the measurement capabilities, network scanner TSMW from Rohde & Schwarz capable of recording up to 32 cells operating within the set band was used together with the measurement setup. Both measurement equipment and the scanner contain a Global Positioning System (GPS) receiver such that the data recorded by both systems can be correlated.

### B. Measurement campaign

Measurement campaign was conducted in a vicinity of Aalborg in northern Denmark. While driving, measurement setup was used to record 100 ms snapshots of LTE signal every 5 s and store them for offline post-processing. In



Fig. 2. A van with measurement equipment (inside) and antenna array mounted on a ground plane (roof)

TABLE I  
CHARACTERISTICS OF THE MEASURED ENVIRONMENT

Route index	Measurement environment	Short description
Route 1	Dominant rural and suburban	Small houses and meadows, seldom deployed Base Stations (BS)
Route 2	Highway and urban	Blocks up to the 3 <sup>rd</sup> floor in the urban part, medium density of BS
Route 3	Highway and dense urban	Blocks up to the 6 <sup>rd</sup> floor, high density of BS
Route 4	Suburban	University buildings, high density of BS

parallel, network scanner recorded the network information with approximately 100 ms granularity. Four routes were chosen for the experiment representing different propagation environments and are summarized in Table I. Each route was driven twice, each time recording the carrier frequency of a different network operator operating within the LTE band 3. In total more than 150 km were driven and more than 6000 snapshots were recorded. Please note that the speed of the vehicle varied from stationary (while waiting at the red lights) up to 100 km/h on a highway.

Figure 3 presents the three driven routes. Route 4 although not shown here due to space constraints is also used for the analysis of the interference as described later.

## III. POST-PROCESSING

In this section post-processing of the recorded data is described, for both measurement setup and the scanner. Each of the data snapshot is processed independently using Matlab in order to compare the performance of different receiver types: a single antenna receiver, MRC and receive beamforming. Scanner information is processed in order to better understand the level of interference in all measured points. The entire



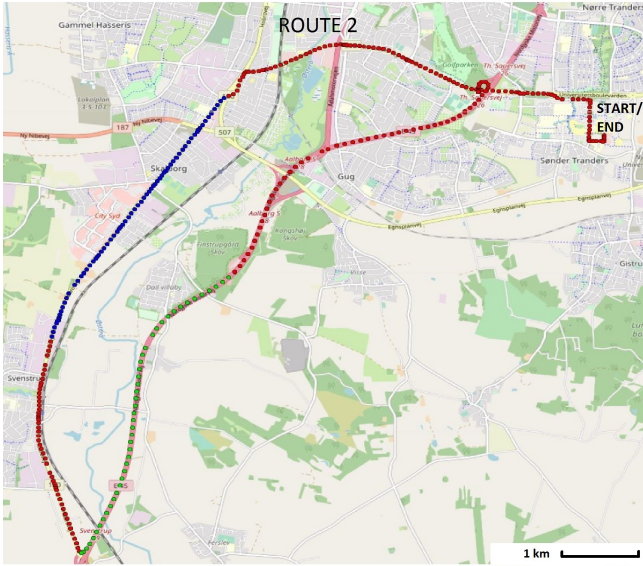

Fig. 3. Three driven routes

process was thoroughly explained in [12], therefore in the next subsection only the summary of processing is outlined.

#### A. Receiving techniques

To study a single antenna receiver, one of the sixteen recorded data streams is used, while others are discarded. The signals recorded by the selected antenna are processed in the receiver built based on the Matlab LTE toolbox. In the receiver, synchronization based on the synchronization signals, channel and frequency offset estimations are performed. Two LTE control channels - Master Information Block (MIB) and System Information Block 1 (SIB1) are decoded and the SINR of the latter is computed and used as a metric for comparison among different receivers. Post processing using MRC is very similar to the single antenna receiver but the processed signal is obtained by combining the sixteen recorded data streams. We refer to [12] for further details on the receiver processing.

In order to assess the performance of the receive beamforming technique, one need to know the optimal direction where the beam should be pointed. As in this work we focus on the ideal performance of the technique (and assume no Angle of Arrival (AoA) information available), for each snapshot 360 beams pointing towards different directions (in both elevation and azimuth planes) using conventional beamformer with 3 dB beamwidth of  $22.5^\circ$  are created. By performing the entire processing for each of the beams, the optimal one can be found as the beam which results in the highest SIB1 SINR. This beam is used for comparison with other receiving techniques, while others are discarded.

#### B. Scanner processing

Scanner recordings were processed in order to characterize interference in the vicinity of the receiver. For each of the snapshots, scanner records the information of up to 32 different cells providing among others the Cell ID and Reference Signals Received Power (RSRP) of each decodable cell. Knowing the Cell ID of the serving cell (based on the information decoded from the MIB), this entry can be excluded from the scanner data. In this way, it will only contain the list of interfering BS with respective RSRPs. In this work two different metrics on how to quantify interference are used. First, the Dominant Interference Ratio (DIR) is computed as below:

$$\text{DIR} = 10 \log_{10} \frac{\max(\text{RSRP})}{\sum_{k=1}^K \text{RSRP}(k) - \max(\text{RSRP}) + n} \quad (1)$$

where RSRP is a vector of  $K$  interfering RSRPs and  $n$  is the thermal noise power computed as:

$$n = -174 + 10 \log_{10}(b) \quad (2)$$

where  $b$  is the bandwidth of the decoded LTE network in Hz (15 or 20 MHz). Computed DIR can reveal if there is a strong dominant interferer potentially harming the performance of the receiver.

As a second metric to describe the interference, the sum of interferers is computed as a total number of interferers with

reported RSRP higher than an arbitrary value of -100 dBm. Imposed threshold is used to exclude the cells which due to the low RSRP are only sporadically reported by the scanner. Since in most cases each interfering signal comes with different AoA, it is worth to study its impact on the performance of the receive beamforming. It is worth to notice that there were some special case snapshots for which scanner reported only one cell (a serving cell), meaning that in a given measurement position interfering signals were too weak to be decoded.

#### IV. PERFORMANCE ANALYSIS

##### A. Performance evaluation of multi-antenna receivers

First, the instantaneous SINR reported for each snapshot and receiver type is plotted against the covered distance for three different routes on Figure 4. As can be noted, the SINR values vary rapidly with distance, due to large and small scale fading. It is worth to indicate that as each of the snapshots is treated independently, each receiver is always connected to the best serving cell without any handover-related considerations.

Two general trends are visible. As expected the single antenna receiver (blue line) generally results in the lowest reported SINR value. The performance of MRC (black line) and receive beamforming (magenta line) is roughly comparable, but some parts of the route where beamforming provides substantial gain over MRC can be visually identified and are marked with dashed rectangles on the figure. After recovering the GPS information for the identified snapshots and plotting them on the map (green and blue points on Figure 3) one can notice that the regions where beamforming performs better than MRC are highway and rural parts where a higher probability of Line of Sight (LoS) link to the BS is expected.

The Empirical Cumulative Distribution Functions (ECDFs) of computed SINR are presented on Figure 5 for three studied routes to quantify the SINR of each receiver type. In up to 20% of cases, the SINR of the single antenna receiver is lower than 0 dB which can potentially harm the connection reliability. Moreover, single antenna receiver has approximately 2 dB lower average (50-th percentile) SINR in the dense urban scenario than in rural and suburban environments, which can be explained by the increased levels of interference due to cell densification. This performance drop is negligible for the MRC and receive beamforming as both methods benefit from the spatial diversity.

For each route, there is on average 5 to 8 dB SINR gain of both multi antenna techniques over a single antenna receiver. The average gains in this range were expected as the simulated maximum directional gain of the array was ~8 dB. Only a few snapshots with SINR lower than 0 dB were recorded, which indicates the benefits of using multiple antenna system for improved network connectivity. Slight gains (up to 1.5 dB) of beamforming over MRC are visible especially in the upper tail of the ECDFs, further confirming higher beamforming gains in visually identified regions and similar performance elsewhere. As highway accounted for a substantial part of the second route, the observed beamforming gains are higher than in different environments.

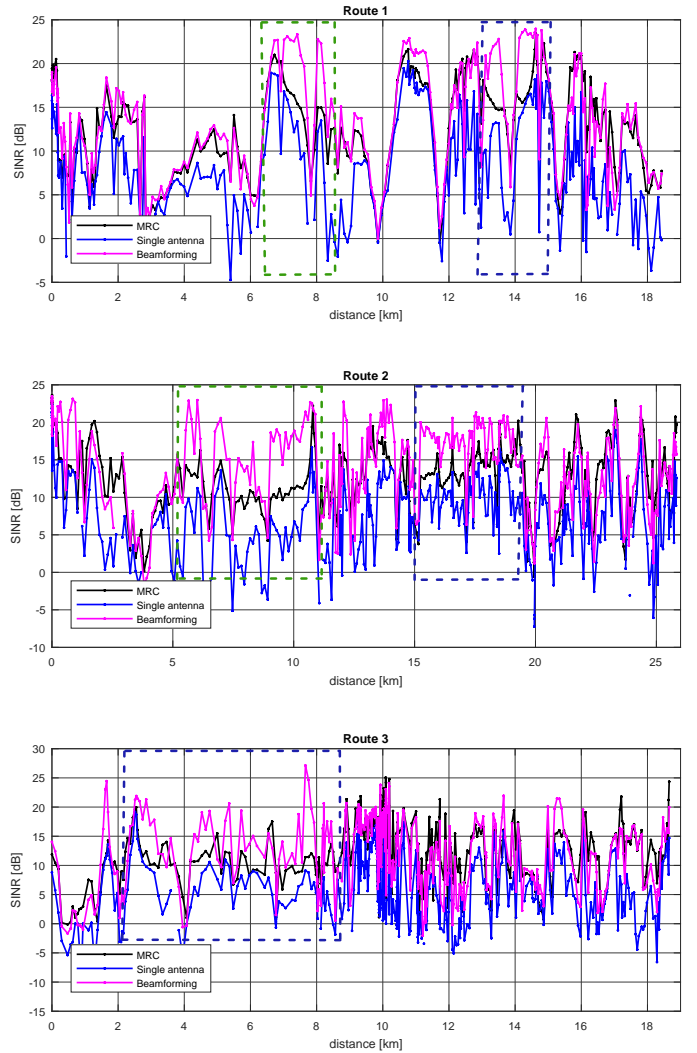

Fig. 4. Instantaneous SINR for different receiver types measured at routes 1, 2 and 3

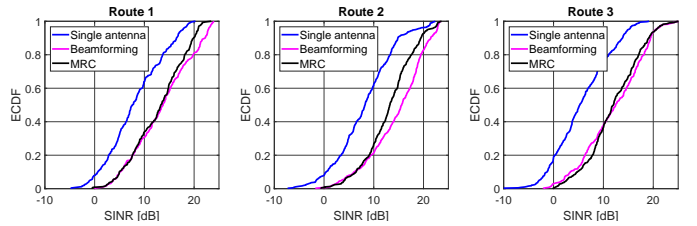

Fig. 5. Empirical Cumulative Distribution Functions of instantaneous SINR for different receiver types

##### B. Impact of interference on the performance of multi-antenna receivers

Trying to better understand the origin of improved beamforming performance with respect to the MRC receiver, in this subsection we focus on the impact of interference on these two receiver types. All results displayed next are generated from the entire set of measurements. Figure 6 presents how the instantaneous SINR of receive beamforming changes with the

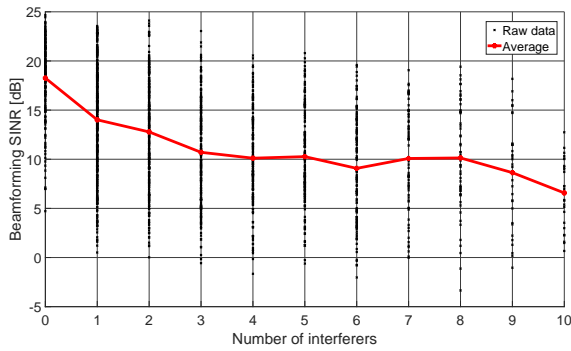

Fig. 6. Impact of number of interferers on receive beamforming SINR

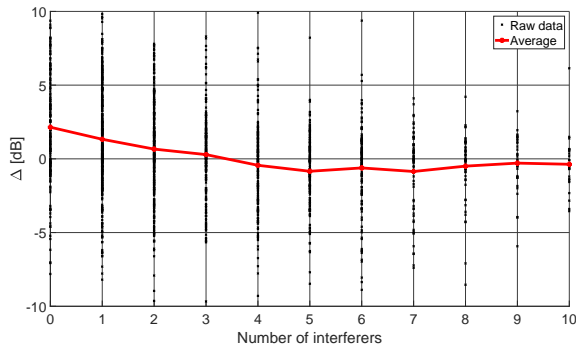

Fig. 7. Impact of the number of interferers on receive beamforming gains

number of significant interferers. While black dots represents the measured data, the red line shows the computed mean for each number of interferers. As expected, the lower the number of interferers, the higher the SINR. With fewer interferers, probability of interfering signal being captured within the main lobe of the receiver is generally lower leading to higher SINR.

Figure 7 shows how the instantaneous beamforming gain over the MRC receiver  $\Delta$  computed in dB scale as:

$$\Delta = \text{SINR}_{\text{beam}} - \text{SINR}_{\text{MRC}} \quad (3)$$

changes with the number of interferers. Looking at the averaged values, it is clearly visible that the performance of both receivers is comparable in a presence of multiple interference sources. Receive beamforming provides up to 2.5 dB average SINR gain when there are no significant interferers decoded and only the sporadic, low power interfering sources are present.

In order to capture the influence of all reported interferers, Figure 8 presents how the beamforming gain  $\Delta$  depends on the DIR, while Figure 9 presents the histogram of the gains for the special case of snapshots where scanner did not report any interference. Interestingly, beamforming provides higher average gain in cases when DIR is high. Also points corresponding to high beamforming gains visually identified at Figure 4 in most cases are related to the high DIR. These gains can be intuitively explained as there is a high probability that the AoA of the strongest interferer would be

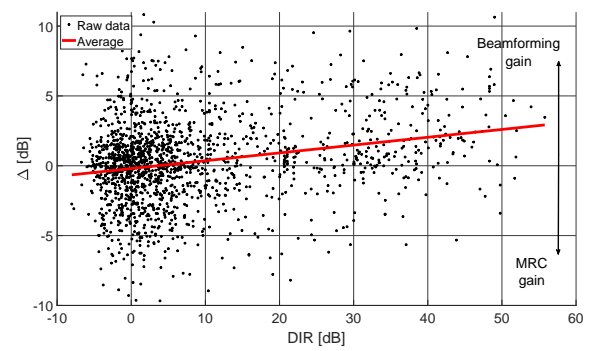

Fig. 8. Dependence of DIR on receive beamforming gains

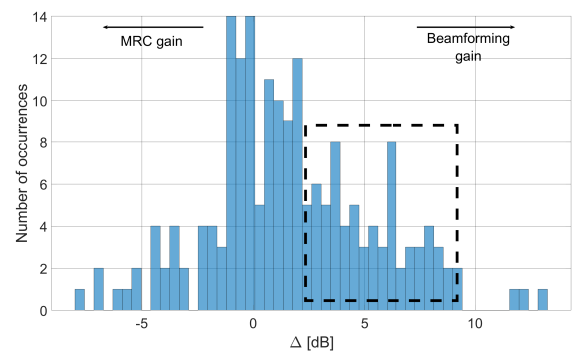

Fig. 9. Receive beamforming gains when no interference was reported by the scanner

located outside of the main beam of the receiver and due to the lower antenna gain in this direction its power would be reduced. MRC on the contrary does not account for the interference and suffers from its presence. It is expected that the Interference Rejection Combining (IRC) receiver would perform significantly better than MRC in studied scenarios given its capability of suppressing a limited number of relevant interferers. However, it would require an accurate estimate of the interferers' channel responses, which might not be feasible in practice.

Histogram presented at Figure 9 further confirms the assumption that beamforming can provide higher gains with a limited number of interfering sources. Theoretically, if there is no interference, the performance of both receive beamforming and MRC should be identical. This can be observed at the figure as for the most occurrences there is no gain for any of the methods or a very limited gain of MRC. However in reality, there can always be some interference sources which were not decoded by scanner for example due to their low SINR. This situation may not only occur for low power interferers, but also in case of multiple interfering signals with significant power and similar AoA, that cannot be decoded due to their strong mutual interference. In the latter cases, as marked by the black rectangle, beamforming can provide a substantial gain over MRC.

Finally, as an indication for further study, the potential

TABLE II  
LOCATION OF THE STRONGEST INTERFERING SOURCE

Percentage of snapshots with the interferer coming from the same BS	37%
Percentage of snapshots with the interferer coming from different BS	63%

impact of the geographical location of the strongest interfering source on the observed results is studied. As most of the BS towers are usually composed of three cells with antennas pointing towards different sectors, Table II quantifies how often the strongest observed interferer comes from the different sectors of the same BS. Surprisingly, even though different sectors are usually spatially separated (each cell points into another direction) in 37% of the measured cases the strongest interferer is located at the same BS tower. Although no correlation between beamforming gain  $\Delta$  and location of the interferer was found, this information indicates that if imposed, cooperation between just the different sectors of the same BS should improve the overall system performance.

## V. CONCLUSIONS

In this work, the performance of multi-antenna receiver techniques for C-V2X communications was studied based on data recorded in experimental campaign. The observed 8 dB average SINR gains with respect to a single antenna system are comparable for both MRC and receive beamforming. However as our measurements indicate, instantaneous gains depend on the measured environment. Obtained results indicate superior performance of beamforming techniques over MRC in LoS scenarios (highway and rural areas) while ensuring similar performance in urban environments. Moreover, receive beamforming was found to provide up to 2.5 dB SINR gain over the MRC receiver in a presence of a strong single dominant interferer. In scenarios with larger number of weaker interferers the performance of both multi antenna receivers was found to be comparable.

As an indication for further study, it has been found that in 37% of the cases, the strongest interfering source was located at the same BS tower. In such cases interference mitigation techniques may be used for signal quality improvement.

## REFERENCES

- [1] Z. MacHardy, A. Khan, K. Obana, and S. Iwashina, "V2X access technologies: Regulation, research, and remaining challenges," *IEEE Communications Surveys Tutorials*, vol. 20, pp. 1858–1877, thirdquarter 2018.
- [2] S. Chen, J. Hu, Y. Shi, Y. Peng, J. Fang, R. Zhao, and L. Zhao, "Vehicle-to-everything V2X services supported by LTE-based systems and 5G," *IEEE Communications Standards Magazine*, vol. 1, no. 2, pp. 70–76, 2017.
- [3] "Study on enhancement of 3GPP support for 5G V2X services (release 15)," Tech. Rep. TS 22.886 V15.1.0, 3GPP, 2017.
- [4] "Architecture enhancements for V2X services (release 15)," Tech. Rep. TS 23.285 V15.0.0, 3GPP, March 2018.
- [5] H. Khan, P. Luoto, M. Bennis, and M. Latva-aho, "On the application of network slicing for 5G-V2X," in *European Wireless 2018; 24th European Wireless Conference*, pp. 1–6, May 2018.
- [6] M. Boban, K. Manolakis, M. Ibrahim, S. Bazzi, and W. Xu, "Design aspects for 5G V2X physical layer," in *2016 IEEE Conference on Standards for Communications and Networking (CSCN)*, pp. 1–7, October 2016.
- [7] "V2X functional and performance test report; test procedures and results," Tech. Rep. 5GAA P-180106, 5GAA Automotive Association, October 2018.
- [8] C. F. Mecklenbrauker, A. F. Molisch, J. Karedal, F. Tufvesson, A. Paier, L. Bernado, T. Zemen, O. Klemp, and N. Czink, "Vehicular channel characterization and its implications for wireless system design and performance," *Proceedings of the IEEE*, vol. 99, pp. 1189–1212, July 2011.
- [9] "WINNER II channel models," Tech. Rep. D1.1.2 ver. 1.1, WINNER II Project, February 2008.
- [10] "METIS channel models," Tech. Rep. D1.4 ver. 3, Mobile and wireless communications Enablers for the Twenty-twenty Information Society, November 2012.
- [11] I. Maskulainen, P. Luoto, P. Pirinen, M. Bennis, K. Horneman, and M. Latva-aho, "Performance evaluation of adaptive beamforming in 5G-V2X networks," in *2017 European Conference on Networks and Communications (EuCNC)*, pp. 1–5, June 2017.
- [12] T. Izydorczyk, M. Bucur, F. M. L. Tavares, G. Berardinelli, and P. Mogenssen, "Experimental evaluation of multi-antenna receivers for UAV communication in live LTE networks," *Globecom workshop on Wireless Networking and Control for Unmanned Autonomous Vehicles*, December 2018.
- [13] T. Izydorczyk, F. M. L. Tavares, G. Berardinelli, M. Bucur, and P. Mogenssen, "Angular distribution of cellular signals for UAVs in urban and rural scenarios," *Accepted at European Conference on Antennas and Propagation (EuCAP 2019)*, March 2019.