



Aalborg Universitet

AALBORG UNIVERSITY
DENMARK

An Alternative Realization of Droop Control and Virtual Impedance for Paralleled Converters in DC Microgrid

Jin, Zheming; Guerrero, Josep M.; Li, Mingshen

Published in:

Proceedings of 2018 IEEE Energy Conversion Congress and Exposition (ECCE)

DOI (link to publication from Publisher):

[10.1109/ECCE.2018.8557628](https://doi.org/10.1109/ECCE.2018.8557628)

Publication date:

2018

Document Version

Early version, also known as pre-print

[Link to publication from Aalborg University](#)

Citation for published version (APA):

Jin, Z., Guerrero, J. M., & Li, M. (2018). An Alternative Realization of Droop Control and Virtual Impedance for Paralleled Converters in DC Microgrid. In *Proceedings of 2018 IEEE Energy Conversion Congress and Exposition (ECCE)* (pp. 3765-3770). IEEE. IEEE Energy Conversion Congress and Exposition <https://doi.org/10.1109/ECCE.2018.8557628>

General rights

Copyright and moral rights for the publications made accessible in the public portal are retained by the authors and/or other copyright owners and it is a condition of accessing publications that users recognise and abide by the legal requirements associated with these rights.

- ? Users may download and print one copy of any publication from the public portal for the purpose of private study or research.
- ? You may not further distribute the material or use it for any profit-making activity or commercial gain
- ? You may freely distribute the URL identifying the publication in the public portal ?

Take down policy

If you believe that this document breaches copyright please contact us at vbn@aub.aau.dk providing details, and we will remove access to the work immediately and investigate your claim.

An Alternative Realization of Droop Control and Virtual Impedance for Paralleled Converters in DC Microgrid

Zheming Jin, Josep M. Guerrero, Mingshen Li

Department of Energy Technology

Aalborg University

Aalborg, Denmark

zhe@et.aau.dk

Abstract— In this paper, an alternative realization method of droop control and virtual impedance for paralleled converters in DC microgrids is proposed as complement to the existing method. The major feature of the proposed realization is that the virtual impedance behavior is realized by using current reference together with a properly designed low-pass filter. Therefore, it will inherently get rid of the noise problem in real-world measurement, which is critical when realizing inductive virtual components. In addition to that, the impact of low-pass filter used in the proposed method on the dynamic performance is also comparatively studied. To validate the proposed method, simulations and experiments are carried out. The results show that the proposed method can be fully compatible with existing methods. Moreover, the low-pass filter is proven to be optional, however, with a specially designed low-pass filter, the transient response of the system can be modified significantly.

Keywords—DC microgrids, virtual impedance, droop control, transient response, stability.

I. INTRODUCTION

DC microgrids (MGs) are drawing great attention due to their convenience and high efficiency in integrating renewable energy sources, energy storage systems and modern electronic loads, especially in off-grid or islanded applications [1], [2]. Power converters are playing a key role in DC microgrids, providing mandatory interface between different kinds of energy sources and the DC distribution network. To coordinate these converters, droop control, especially virtual resistance based voltage droop control method is the most commonly used solution as primary-level solution. At the same time, different kinds of virtual impedance design has been proposed and widely adopted in stability enhancement [3-5], dynamic power management [6-9], and to improve transient response of the system [10-11]. However, both virtual resistance based droop controller or virtual impedance control method have to face the noise problem of real-world sensor, especially those using inductive virtual component which requires differentiator to realize.

In this paper, an alternative realization method of droop control and virtual impedance for paralleled converters in DC microgrids is proposed. The major feature of the new proposal is that the virtual component is realize by using estimated

current instead of real current. Therefore, the measurement noise will not be able to affect the system directly. As a result, the proposed can get rid of the noise problem, which is a major concern when using inductive virtual impedance.

In the new proposal, one of the key component is the low-pass filter used to emulate the behavior of inner-current loop. If the cutting frequency of the filter is set properly, the new proposal will provide equal performance compared to the conventional realization. To better analyze the proposed method, the impact of the low-pass filter on the dynamic performance is also comparatively studied. Both cases with higher or lower cutting frequency has been analyzed. The results prove that the low-pass filter can be optional, however, with specially designed low-pass filter, the performance of the system can be modified greatly and surpass the conventional realization method.

II. PRINCIPLE OF RPROPOSED REALIZATION

For both virtual impedance control and voltage droop control, a universal control architecture can be illustrated as shown in Fig.1.

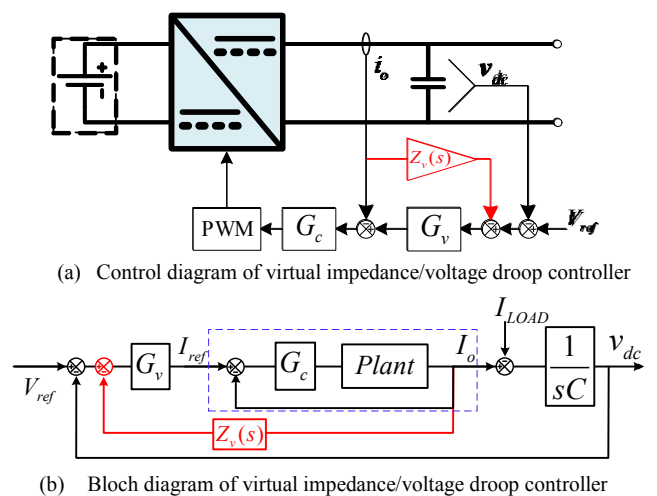
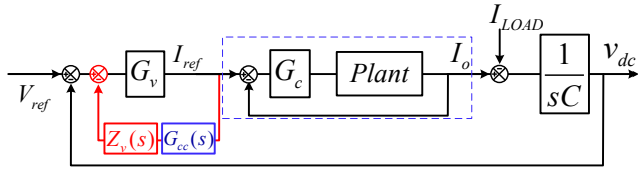
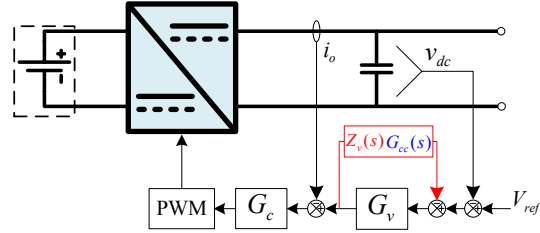

Fig. 1. Generalized control architecture of virtual impedance/voltage droop control method: (a) control diagram; (b) block diagram.



(a) Derived equivalent alternative block diagram



(b) Derived equivalent alternative control diagram

Fig. 2. Derived equivalent alternative realization of virtual impedance/voltage droop control method: (a) block diagram; (b) control diagram.

For this dual-loop-controller based control architecture, the inner-loop (i.e. current loop) is always much faster when compare to the outer-loop (i.e. voltage loop). For this reason, the behavior of inner current loop can be simplified to be a first-order delay, with time constant determined by its control

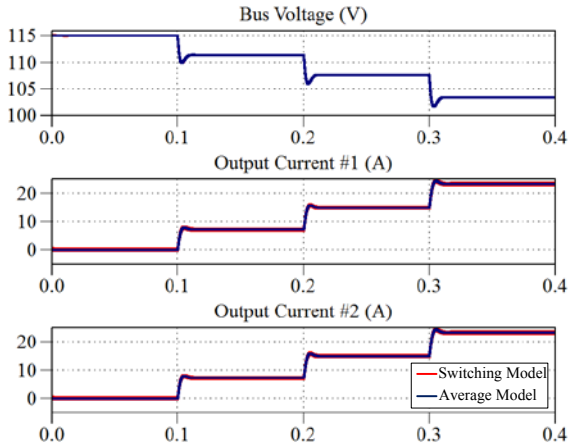

(a) DC bus voltage and output currents of converters

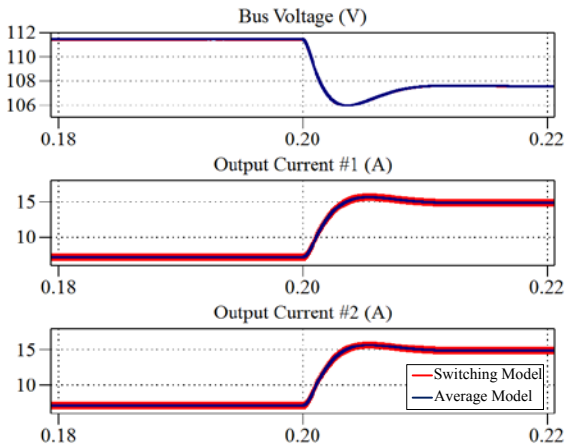

(b) Enlarged transient response of converters

Fig. 3. Simulation results using conventional droop control method.

bandwidth, when analyzing the behavior of this dual-loop system. Nevertheless, on the basis of the same assumption, according to the control theory, an equivalent alternative of Fig. 1(b) can be derived, which is illustrated in Fig. 2(a). Correspondingly, the control architecture can be illustrated in Fig. 2(b). As the behavior of the high-bandwidth inner current loop is assumed to be similar to a first-order delay with time constant determined by the control bandwidth, a single low-pass filter can be used to emulate its behavior. Discussion on the low-pass filter and its design will be presented in the next section of this paper.

In this way, the droop control and virtual impedance method can be achieved using current reference instead of the output current. Thus, with the proposed method, the impact of noise and current ripple in the measurement will be inherently prevented.

To validate the proposed method, study case DC microgrid composed by two paralleled DC/DC converters is simulated using PLECS. The parameters used for these simulations can be found in Table I. The simulation results are shown in Fig. 3 and Fig. 4. For comparison, a state-space based average-value model of the study case controlled by conventional droop control (detailed in [12]) is also included in the simulation as a average-value reference due to its good accuracy.

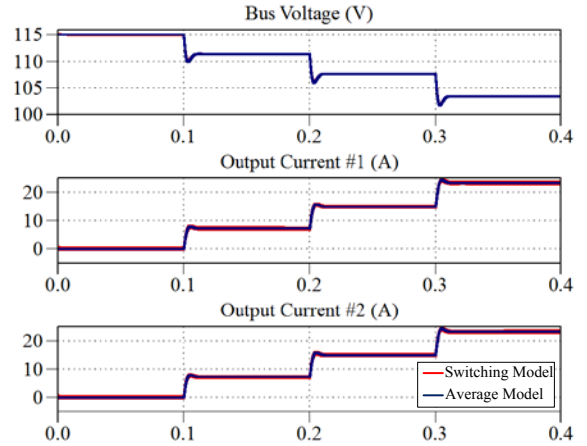

(a) DC bus voltage and output currents of converters

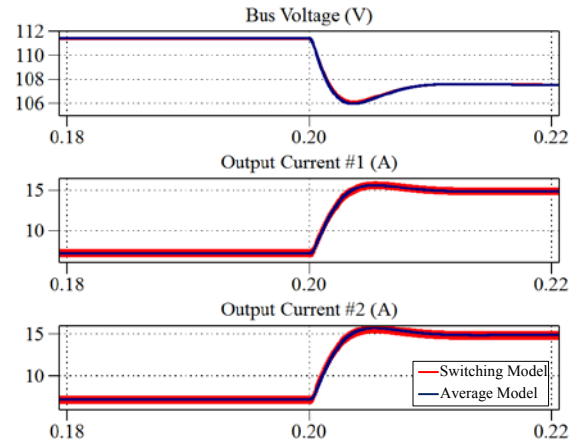

(b) Enlarged transient response of converters

Fig. 4. Simulation results using proposed alternative droop method.

TABLE I. PARAMETERS OF SIMULATED STUDY CASES

Description of the Parameter	Symbol	Value
Basic Voltage Reference	V_{ref}	115 V
Source Voltage	E_i	230 V, 230 V
Inductance of Buck Converters	L_i	8mH,
Stary Resistance of inductors,	r_i	0.1 Ω
Switching Frequency	f_{sw}	10 kHz
Virtual Resistances	R_{vi}	0.5 Ω
Total Capacitance in DC Bus	C	3.3 mF
Voltage PI Controller	K_{pvi}, K_{ivi}	1, 50
Current Controller	K_{pci}, K_{ici}	0.05, 1
Load Change	P_{Load}	2kW/step

The simulation results show that the transient response of conventional realization and proposed method has only neglectable difference. Although the difference is very small, it is still noteworthy that the transient voltage drop due to load increasing is slightly smaller with the proposed method when compared with conventional methods.

III. IMPACT OF LOW-PASS FILTER

A noteworthy point of the proposed alternative virtual impedance method is using low-pass filter to emulate the delay effect of the current loop, and therefore providing an equivalent to the conventional methods. However, it is also considerable that the inner current loop will have a sufficiently high control bandwidth (usually up to several hundred hertz). As a result, the low-pass filter used in the proposed method need to have a high cutting frequency, which will make the low-pass filter itself very close to unity gain. At the same, time, the effect of using other time constant remains unknown. For this reason, the impact of low-pass filter with different time constant design on the proposed method is analyzed in this section.

To analyze the behavior of the dual-loop based control system shown in Fig.1(b) and Fig.2(a), the author assumes that the inner current loop is well-designed with sufficiently high bandwidth, which make it possible to simplify it as a first-order inertial component with time constant $\tau_c=1/\omega_c$, where ω_c stands for the control bandwidth of inner current loop. With this assumption, the behavior of conventional droop controlled DC/DC converter can be formulated as:

$$I_o(s) = \frac{G_v(s)G_{cc}(s)}{1 + Z_v(s)G_v(s)G_{cc}(s)}(V_{ref} - u(s)) = \frac{V_{ref} - u(s)}{Z_{con}(s)} \quad (1)$$

$$Z_{con}(s) = \frac{1 + Z_v(s)G_v(s)G_{cc}(s)}{G_v(s)G_{cc}(s)} = \frac{1}{G_v(s)G_{cc}(s)} + Z_v(s) \quad (2)$$

where the general-case controller (PI based voltage/current control loop) is considered as $G_v(s)$ and the transfer function

of voltage controller and close-loop transfer function of current loop are considered as $G_{cc}(s)$, as detailed in (3):

$$G_v(s) = k_p + \frac{k_i}{s} = k_p \frac{s + \alpha}{s}; \quad G_{cc}(s) = \frac{\omega_c}{s + \omega_c} = \frac{1}{\tau_c s + 1}; \quad (3)$$

At the same time, the behavior of proposed control method can be formulated as:

$$I_o'(s) = \frac{G_v(s)}{1 + Z_v(s)G_{LPF}(s)G_v(s)}(V_{ref} - u(s)) \times G_{cc}(s) = \frac{V_{ref} - u(s)}{Z_{con}'(s)} \quad (4)$$

$$Z_{con}'(s) = \frac{1 + Z_v(s)G_v(s)G_{LPF}(s)}{G_v(s)G_{cc}(s)} = \frac{1}{G_v(s)G_{cc}(s)} + Z_v(s) \frac{G_{LPF}(s)}{G_{cc}(s)} \quad (5)$$

In this case, the virtual impedance that the proposed method added to the system will be:

$$\begin{aligned} Z_{eq}(s) &= Z_v(s) \frac{G_{LPF}(s)}{G_{cc}(s)} = Z_v(s) \frac{\tau_c s + 1}{\tau_{LPF} s + 1} \\ &= Z_v(s) + Z_v(s) \frac{(\tau_c - \tau_{LPF})s}{\tau_{LPF} s + 1} \end{aligned} \quad (6)$$

while the conventional method will always add exactly $Z_v(s)$ to the system.

As indicated in (5) and (6), with time constant different from τ_c , an additional impedance will appear. On the one hand, if the low-pass filter has cutting frequency higher than the control bandwidth ω_c (i.e. $\tau_{LPF} < \tau_c$), the last term of (6) will be positive, as a result, additional higher-order (usually inductive) virtual component will be performed. On the contrary, if the cutting frequency is lower than the control bandwidth ω_c (i.e. $\tau_{LPF} > \tau_c$), the additional impedance will tend to perform negative virtual component that will cancel some of the intrinsic impedance.

In this paper, two most representative cases are simulated on the basis of the simulation model used in the previous section: (a) the case that low-pass filter is not used (i.e. $\tau_{LPF}=0$), and (b) the case that cutting frequency is set according to cancel the zero of PI controller (i.e. $\tau_{LPF}=1/\alpha$). The simulation results are shown in Fig.5 and Fig.6. In addition to that, the same state-space model used in previous section is also included as the average value reference, and therefore helping judging the performances. It is also noteworthy that the average-value model stands for the conventional droop control method, which means the difference between switching model and average-value model, as shown in Fig. 5, and Fig. 6, is comparison between simulated study case using new proposal and conventional droop control method.

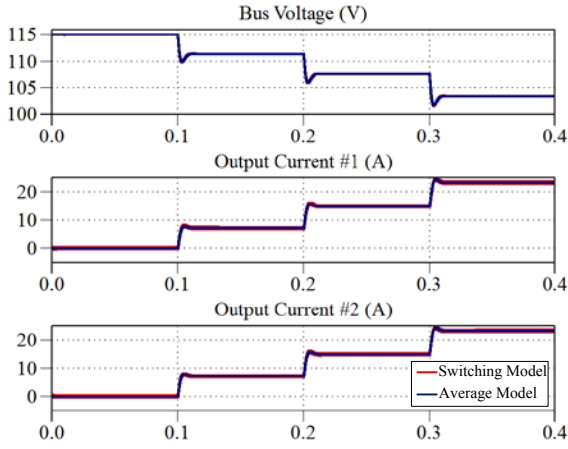

(a) Bus voltage and output currents of converters

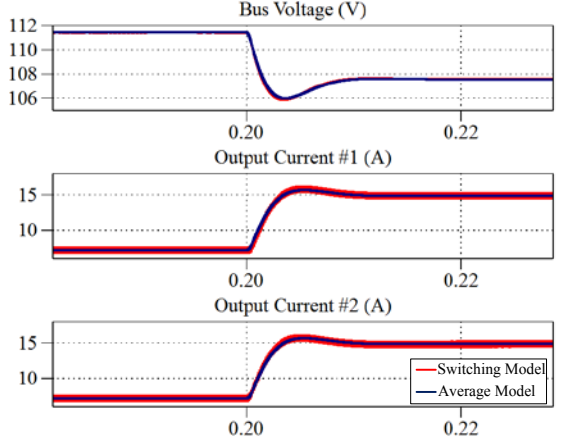

(b) Enlarged transient response of converters

Fig. 5. Simulation results using proposed method without using low-pass filter.

From both simulation, it can be observed that the proposed realization method (with or without using low-pass filter) is fully compliant with more conventional realization. It proves that the low-pass filter used in the proposed method is optional. In addition to that, in Fig. 5, the simulation results show that even without the low-pass filter to emulate the delay behavior of inner current loop, the dynamic response of the proposed method is still comparable to the conventional methods. This is because the control bandwidth of inner current loop is sufficiently high so that the time constants (both τ_c and τ_{LPF}) will be relatively small value (usually very close to zero). Therefore, the impact of removing the low-pass filter, i.e. the additional impedance effect suggested by (6), is very limited and almost neglectable. On the other hand, in Fig. 6, the simulation results show that with a proper designed low-pass filter, the new proposal can surpass the conventional method in terms of transient response of the system. Nevertheless, it is important to point that the simulated study case shown in Fig.6 is not the limitation of selecting time constant for low-pass filter of the new proposal, larger time constant can be still used to obtain even more competitive performance.

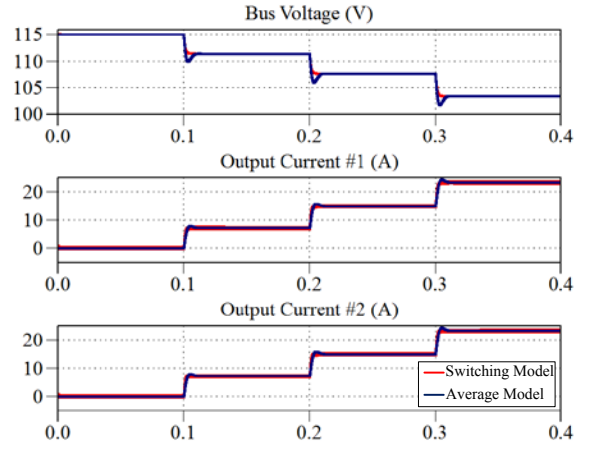

(a) Bus voltage and output currents of converters

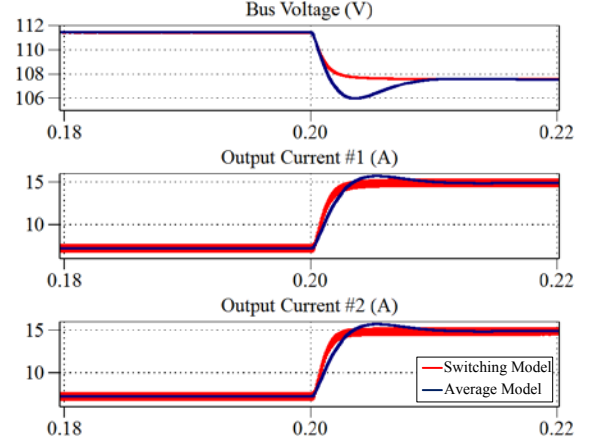

(b) Enlarged transient response of converters

Fig. 6. Simulation results using proposed method together with special designed time constant.

IV. EXPERIMENTAL VALIDATION AND COMPARISON

To validate the proposed method in real-world applications, several experiments have been carried out using our DC microgrid experimental setup which is equipped with four individual DC/DC converters operating in Buck mode (as shown in Fig.7). In this paper, two of four DC/DC converters are used. The key parameters used in these experiments are listed in Table I. A dSpace RTI1006 is used for control, data acquisition, and monitoring the setup during the experiments. Four scenarios are tested, including:

- (1) both converter #1 and converter #2 are controlled by conventional droop method;
- (2) converter #1 is controlled by proposed method with time constant design of $\tau_{LPF}=0$, converter#2 is controlled by conventional droop method;
- (3) converter #1 is controlled by proposed method with time constant design of $\tau_{LPF}=1/\alpha$, converter #2 is controlled by conventional droop method;
- (4) both converters are controlled using proposed method with time constant design of $\tau_{LPF}=1/\alpha$.

TABLE II. PARAMETERS OF EXPERIMENTAL TESTBED

Description of the Parameter	Symbol	Value
Voltage Reference	V_{ref}	120 V
Source Voltage	E_i	240 V, 240 V
Inductance of Buck Converters	L_i	8.6 mH,
Stary Resistance of inductors,	r_i	0.1 Ω
Switching Frequency	f_{sw}	10 kHz
Virtual Resistances	R_{vi}	1 Ω
Total Capacitance in DC Bus	C	3.3 mF
Voltage PI Controller	K_{pvi}, K_{ivi}	1, 50
Current Controller	K_{pci}, K_{ici}	0.05, 1
Resistive Load	R_{Load}	30 Ω

The experimental results of these four scenarios are shown by Fig. 8-11, respectively.

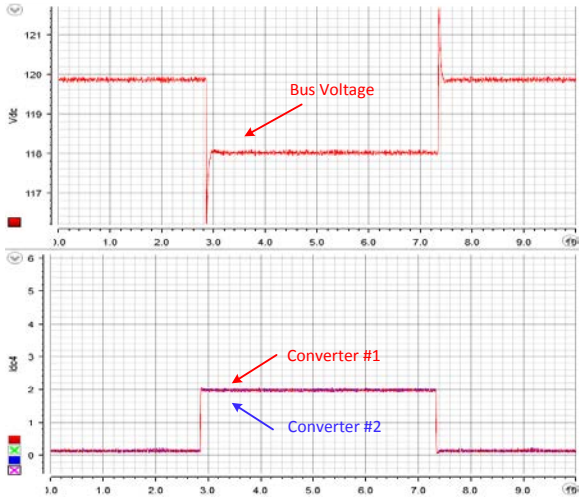

Fig. 8. The experimental results of scenario (1): both converters are controlled by conventional droop method.

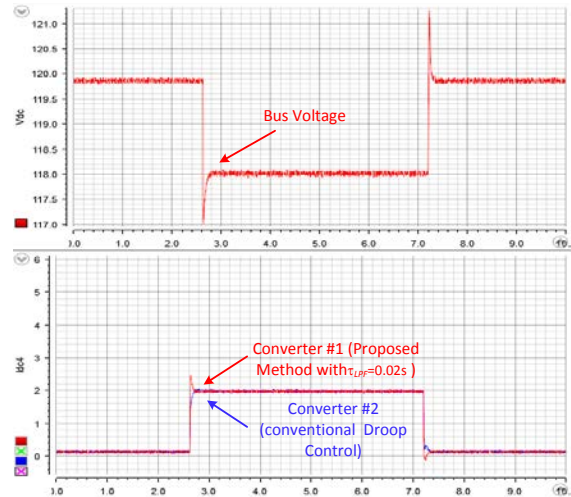

Fig. 10. The experimental results of scenario (3): converter #1 is controlled by proposed method with LPF setting $\tau_{LPF}=1/\alpha=0.02s$.

By comparing the experimental results shown in Fig. 8 and Fig. 9, it can be observed that the transient voltage drop is 1.8V in Fig.8, while the transient voltage drop in response to the same load change is 2.0V in Fig.9. It consists with the simulation results shown in Fig. 5 that the proposed method without low-pass filter will work, but the performance will be slightly worse than the conventional droop method. One step further, it can also be found in Fig. 9 that the output current of converter #1 shows additional delay when compared to the output current of converter #2. It indicates that the additional impedance effect suggested by (6) in the previous analysis does exist. Nevertheless, it proves that even without using low-pass filter, which, to the author's opinion, is a typical case of improper time constant setting, the new proposal will still work and being able to provide acceptable performance compared to the conventional method.

On the other hand, it can be found in Fig. 10 that the transient voltage drop is reduced to 1.0V if a properly designed low-pass filter is adopted in the proposed method, which has surpassed the performance of conventional droop

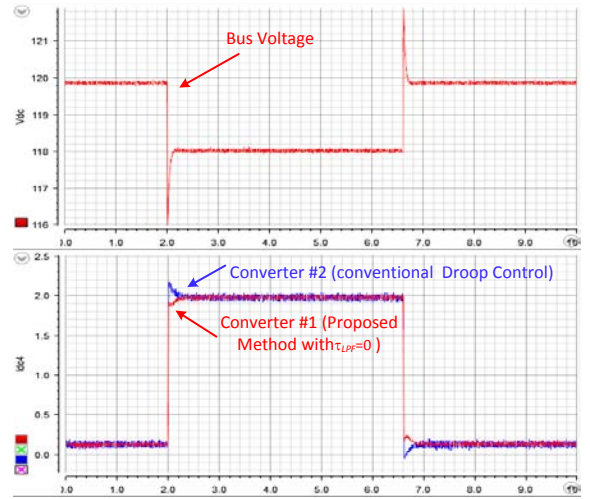

Fig. 9. The experimental results of scenario (2): converter #1 is controlled by proposed method with LPF setting $\tau_{LPF}=0$.

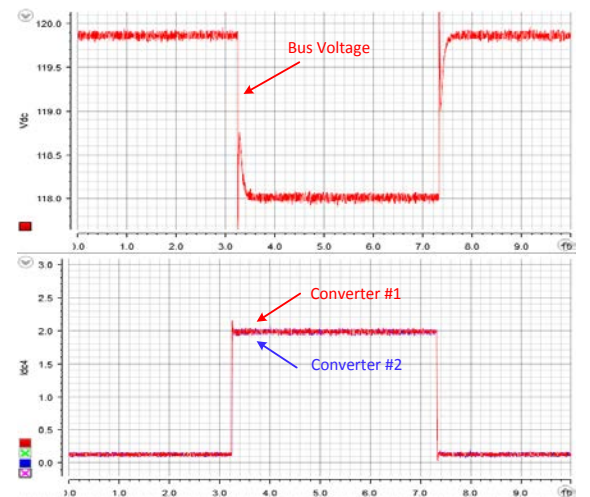

Fig. 11. The experimental results of scenario (4): both converters are controlled by proposed method with LPF setting $\tau_{LPF}=1/\alpha=0.02s$.

method. At the same time, the output current of converter #1 shows reduced delay effect when compared to the output of converter #2 where conventional droop method is used. In addition to that, the experimental results shown in Fig. 11 has further demonstrated that the proposed method, with a proper filter design, will provide better performance in transient response and equal power sharing capability in the steady states.

V. CONCLUSION AND FUTURE WORKS

In this paper, an alternative realization method of droop control and virtual impedance method is proposed for paralleled converters in DC microgrids. The significant feature of the new proposal is to use estimated current constructed by current reference and emulated delay (using low-pass filter) instead of real current in the conventional realization. The mechanism and principle of the new proposal is detailed. In addition to that, the impact of low-pass filter used in the new proposal is comprehensively studied. As a conclusion, the filter can be optional, however, with properly designed filter, the new proposal can offer better performance compared to conventional droop method.

The major benefit of the new proposal can be summarized as following:

- (1) The new proposal can greatly improve immunity to measurement noise, providing more possibilities in virtual impedance design.
- (2) With specially designed low-pass filter, the proposed method can offer new opportunities to improve the system transient response.
- (3) The new proposal is proven to be fully compatible with conventional method, which opens possibilities to combine the new proposal and conventional method to form more flexible solution for virtual impedance design.

REFERENCES

[1] J. M. Guerrero, J. C. Vasquez, J. Matas, L. G. de Vicuna and M. Castilla, "Hierarchical Control of Droop-Controlled AC and DC Microgrids—A General Approach Toward Standardization," in *IEEE Transactions on Industrial Electronics*, vol. 58, no. 1, pp. 158-172, Jan. 2011.

[2] X. Lu, K. Sun, J. M. Guerrero, J. C. Vasquez and L. Huang, "State-of-Charge Balance Using Adaptive Droop Control for Distributed Energy Storage Systems in DC Microgrid Applications," in *IEEE Transactions on Industrial Electronics*, vol. 61, no. 6, pp. 2804-2815, June 2014.

[3] X. Lu, K. Sun, J. M. Guerrero, J. C. Vasquez, L. Huang and J. Wang, "Stability Enhancement Based on Virtual Impedance for DC Microgrids With Constant Power Loads," in *IEEE Transactions on Smart Grid*, vol. 6, no. 6, pp. 2770-2783, Nov. 2015.

[4] Z. Jin, L. Meng and J. M. Guerrero, "Constant power load instability mitigation in DC shipboard power systems using negative series virtual inductor method," *IECON 2017 - 43rd Annual Conference of the IEEE Industrial Electronics Society*, Beijing, 2017, pp. 6789-6794.

[5] L. Guo, S. Zhang, X. Li, Y. W. Li, C. Wang and Y. Feng, "Stability Analysis and Damping Enhancement Based on Frequency-Dependent Virtual Impedance for DC Microgrids," in *IEEE Journal of Emerging*

and Selected Topics in Power Electronics, vol. 5, no. 1, pp. 338-350, March 2017.

[6] Y. Gu, W. Li and X. He, "Frequency-Coordinating Virtual Impedance for Autonomous Power Management of DC Microgrid," in *IEEE Transactions on Power Electronics*, vol. 30, no. 4, pp. 2328-2337, April 2015.

[7] Panbao Wang, Xiaonan Lu, Wei Wang, Dianguo Xu, "Frequency Division Based Coordinated Control of Three-Port Converter Interfaced Hybrid Energy Storage Systems in Autonomous DC Microgrids", *Access IEEE*, vol. 6, pp. 25389-25398, 2018.

[8] M. Nasir, Z. Jin, H. Khan, N. Zaffar, J. Vasquez and J. M. Guerrero, "A Decentralized Control Architecture applied to DC Nanogrid Clusters for Rural Electrification in Developing Regions," in *IEEE Transactions on Power Electronics*.

[9] Z. Jin, L. Meng, J. M. Guerrero and R. Han, "Hierarchical Control Design for a Shipboard Power System With DC Distribution and Energy Storage Aboard Future More-Electric Ships," in *IEEE Transactions on Industrial Informatics*, vol. 14, no. 2, pp. 703-714, Feb. 2018.

[10] M. Hamzeh, M. Ashourloo and K. Sheshyekani, "Dynamic performance improvement of DC microgrids using virtual inductive impedance loop," The 5th Annual International Power Electronics, Drive Systems and Technologies Conference (PEDSTC 2014), Tehran, 2014, pp. 452-457.

[11] Jin, Z., Meng, L., Han, R., Guerrero, J. M., & Vasquez, J. C. (2017). Admittance-type RC-mode Droop Control to Introduce Virtual Inertia in DC Microgrids. In 2017 IEEE Energy Conversion Congress and Exposition (ECCE).

[12] Jin, Z., Meng, L., & Guerrero, J. M. (2017, June). Comparative admittance-based analysis for different droop control approaches in DC microgrids. In DC Microgrids (ICDCM), 2017 IEEE Second International Conference on (pp. 515-522). IEEE.