



Aalborg Universitet

AALBORG UNIVERSITY  
DENMARK

## Energy flexibility for systems with large thermal masses with applications to shopping centers

Petersen, Joakim Børllum; Bendtsen, Jan Dimon; Vogler-Finck, Pierre Jacques Camille; Stoustrup, Jakob

*Published in:*

Proceedings of 2018 IEEE International Conference on Communications, Control, and Computing Technologies for Smart Grids (SmartGridComm)

*DOI (link to publication from Publisher):*

[10.1109/SmartGridComm.2018.8587444](https://doi.org/10.1109/SmartGridComm.2018.8587444)

*Publication date:*

2018

*Document Version*

Accepted author manuscript, peer reviewed version

[Link to publication from Aalborg University](#)

*Citation for published version (APA):*

Petersen, J. B., Bendtsen, J. D., Vogler-Finck, P. J. C., & Stoustrup, J. (2018). Energy flexibility for systems with large thermal masses with applications to shopping centers. In *Proceedings of 2018 IEEE International Conference on Communications, Control, and Computing Technologies for Smart Grids (SmartGridComm)* IEEE. <https://doi.org/10.1109/SmartGridComm.2018.8587444>

### General rights

Copyright and moral rights for the publications made accessible in the public portal are retained by the authors and/or other copyright owners and it is a condition of accessing publications that users recognise and abide by the legal requirements associated with these rights.

- ? Users may download and print one copy of any publication from the public portal for the purpose of private study or research.
- ? You may not further distribute the material or use it for any profit-making activity or commercial gain
- ? You may freely distribute the URL identifying the publication in the public portal ?

### Take down policy

If you believe that this document breaches copyright please contact us at [vbn@aub.aau.dk](mailto:vbn@aub.aau.dk) providing details, and we will remove access to the work immediately and investigate your claim.

# Energy Flexibility for Systems with large Thermal Masses with Applications to Shopping Centers

Joakim Børllum Petersen\*, Jan Dimon Bendtsen\*, Pierre Vogler-Finck† and Jakob Stoustrup\*

\* Department of Electronic Systems, Aalborg University, Denmark  
{jbp, dimon, jakob}@es.aau.dk

† Neogrid Technologies ApS, Aalborg, Denmark  
pvf@neogrid.dk

**Abstract**—In this paper we propose a scheme for managing energy flexibility in buildings with significant thermal masses and centralized climate control, such as commercial buildings, which can be used to provide ancillary services to the local electrical system (demand response). The scheme relies on being able to manipulate the forward flow temperature in the climate control system along with heating/cooling of zones of the building, and thereby controlling the electrical power consumption of the system. A Model Predictive Control law is formulated to provide pre-storage of thermal energy in the manipulated zones without violating comfort requirements.

The scheme is illustrated on a case study of a Danish shopping center, from which actual heating/cooling data have been collected for identification of thermal dynamics. The Coefficient of Performance of the system’s chiller is assumed to have a known dependence on flow and temperature, which is exploited to relate electrical power consumption to forward flow temperature. Simulation studies indicate potentials for significant power curtailment, in the order of 100 kW for one hour for the shopping center as a whole.

## I. INTRODUCTION

The increasingly stochastic electricity production in Denmark [1] imposes new requirements for balancing the production and consumption of energy. As conventional power production is replaced with renewables, so is to a large extent the possibility of providing grid balancing ancillary services. This can, however, be countered by using flexible consumption to provide the necessary grid balancing.

Buildings comprise approximately 2/3 of the total electricity consumption in Denmark [1] and can provide potential load-shifting grid balancing ancillary services, by exploiting thermal comfort requirements, allowing e.g. air temperatures to vary within a certain band. The duration and load magnitude of a load-shifting service is dependent on the allowable temperature fluctuations and on the time constant of the temperature dynamics. The time constant is largely dictated by the thermal capacitances.

The survey papers [2], [3] and [4] give a broad overview of the benefits of deploying thermal storages and other demand side entities for ancillary services, along with insight into various techniques for achieving that purpose.

One of the most prominent of these techniques consists of shifting electric load in time via predictive control. In [5] a control system is demonstrated that allows a pool of household heat pumps to track a power reference; providing flexible

consumption while still adhering to consumer comfort requirements. In [6], a Model Predictive Control (MPC) scheme is proposed and tested in a commercial building, manipulating fan speeds to provide flexibility. In [7] and [8] the energy flexibility of a supermarket refrigeration system and a HVAC chiller for office buildings is aggregated through a predictive control strategy that allows direct control of their combined power consumption; the work in [7] presents experimental verification where power consumption is constrained to be below a certain level.

In this paper we propose a control scheme for managing and exposing energy flexibility, in a certain class of multi-zone buildings with centralized climate control. The approach is based on an RC-equivalent dynamical model of zone temperatures, utilizing MPC with time-dependent constraints to directly manage either power or energy consumption.

The work is part of the Danish *Energy Technology Development and Demonstration Program (EUDP)* project denoted *Smart Energy Shopping Centers (SEBUT)*. The goal of SEBUT is to design intelligent control systems, achieving energy efficient and flexible operations of Danish shopping centers [9]. Given this premise, this paper examines a Danish shopping center and the proposed scheme for managing and exposing flexibility is applied to a small section of this shopping center – including implementation considerations. Simulation experiments are conducted to evaluate the scheme.

In **Section II** the approach is described, including a description of the class of systems considered and how their temperature dynamics are modeled. Then, **Section III** describes the specifics of how energy flexibility can be introduced using time-dependent constraints in an optimal control problem. A case-study of a Danish shopping center is presented in **Section IV** and case-study simulations evaluating the proposed control scheme are shown in **Section V**. Conclusions are given in **Section VI**.

## II. SYSTEM MODEL

The class of systems considered, share the Heating Ventilation and Air Conditioning (HVAC) architecture depicted in **Figure 1**; with central hydronic cooling, hydronic heating and central ventilation. Each thermal zone is equipped with local heating and cooling actuators for control of the temperature of the supplied ventilated air, enabling control of zone temperatures.

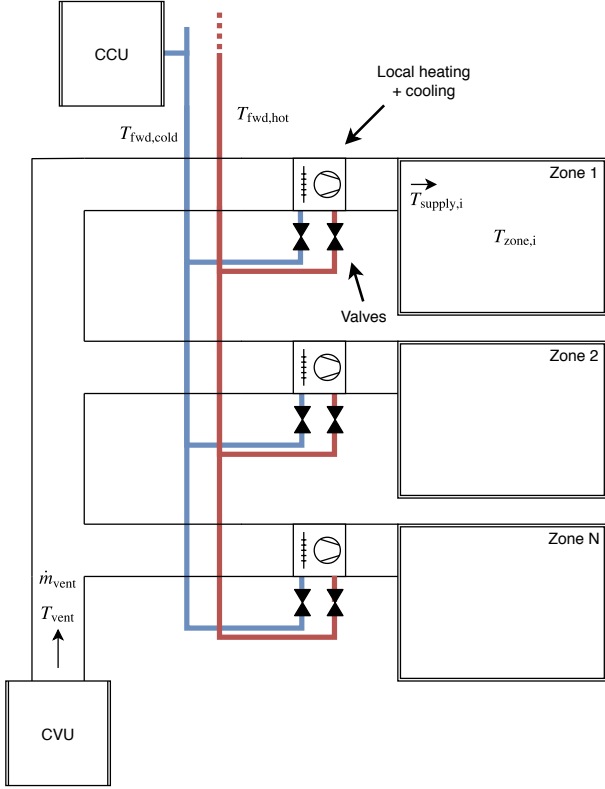

Fig. 1. HVAC architecture for the class of systems treated. Heating and cooling enabled at zone level through distribution of both chilled and heated water to local coils. CCU (Central Cooling Unit) denotes a centralized chiller, supplying several zones with chilled water. CVU denotes a Centralized Ventilation Unit, supplying several zones with ventilated air.

### A. Model of temperature dynamics

A grey-box RC-equivalent modeling paradigm is employed, treating each thermal zone as a lumped thermal capacitance. Let  $N$  be the number of thermal zones. The temperature of the  $i$ -th thermal zone is given by the following differential equation:

$$C_{zone,i} \dot{T}_{zone,i} = \dot{Q}_{adjacent,i} - \dot{Q}_{act,i} + \dot{Q}_{int,i} \quad (1)$$

where  $C_{zone,i}$  is the lumped thermal capacitance of thermal zone  $i$ ,  $T_{zone,i}$  is the temperature of the zone and  $\dot{Q}_{adjacent,i}$  is the heat flow to/from adjacent zones.  $\dot{Q}_{act,i}$  is the heat flow supplied by the local heating/cooling actuator and  $\dot{Q}_{int,i}$  models the internal heat gain, e.g. heat gain from occupancy, lighting and appliances. A thorough description of the details of the models is given in [10], which systematically introduces the dynamics.

The actuator heat flow,  $\dot{Q}_{act,i}$ , is dependent on the flow of air into a zone and the temperature of that air,  $T_{supply,i}$ . The dynamics of  $T_{supply,i}$  are modeled as:

$$C_{act,i} \dot{T}_{supply,i} = \dot{Q}_{act,i} + \dot{Q}_{CCU,i} + \dot{Q}_{CHU,i} + \dot{Q}_{CVU,i} \quad (2)$$

where  $C_{act,i}$  is the lumped thermal capacitance of the actuator and  $T_{supply,i}$  is the temperature of the supply air to the zone.  $\dot{Q}_{CCU,i}$  is heat flow from central cooling,  $\dot{Q}_{CHU,i}$  is heat flow from central heating and  $\dot{Q}_{CVU,i}$  is heat flow from central

ventilation. Equations for all zones are collected, by looking at the system as a graph. We collect all the thermal zones as nodes in the graph  $\mathcal{G}$ . An edge between two zones exists if they are physically adjacent. The edges are weighted by the thermal conductance between the zones. We now describe the dynamics in matrix/vector form as:

$$\dot{\mathbf{Q}}_{adjacent} = -\mathbf{Q}(\mathcal{G}) \mathbf{T} \quad (3)$$

$$\mathbf{T} = [T_{zone,1}, T_{zone,2}, \dots, T_{zone,N}]^T \quad (4)$$

where  $\mathbf{Q}(\mathcal{G})$  is the Laplacian matrix[11] of  $\mathcal{G}$  and  $\mathbf{v}^T$  denotes  $\mathbf{v}$  transposed. Summarizing the model as:

$$\mathbf{C} \dot{\mathbf{T}} = -\mathbf{Q}(\mathcal{G}) \mathbf{T} - \dot{\mathbf{Q}}_{act} + \dot{\mathbf{Q}}_{int} \quad (5)$$

$$C_{act} \dot{\mathbf{T}}_{supply} = \dot{\mathbf{Q}}_{act} + \dot{\mathbf{Q}}_{CCU} + \dot{\mathbf{Q}}_{CHU} + \dot{\mathbf{Q}}_{CVU} \quad (6)$$

$$\dot{\mathbf{Q}}_{act} = \dot{\mathbf{m}}_{air} c_{p,air} (\mathbf{T}_{supply} - \mathbf{T}) \quad (7)$$

where  $\dot{\mathbf{m}}_{air}$  is the mass flow of air supplied to the zones. The combined cooling and heating loads are given by:

$$\dot{Q}_{cool} = \sum_{i=0}^N \dot{Q}_{CCU,i} \quad (8)$$

$$\dot{Q}_{heat} = \sum_{i=0}^N \dot{Q}_{CHU,i} \quad (9)$$

As such, the power consumption in each case can be calculated as:

$$P_{cool} = \frac{\dot{Q}_{cool}}{\eta_{cool} \text{COP}_{cool}} \quad (10)$$

$$P_{heat} = \frac{\dot{Q}_{heat}}{\eta_{heat} \text{COP}_{heat}} \quad (11)$$

where COP is the Coefficient of Performance (COP) and  $\eta$  is a general efficiency factor, covering e.g. transport loss and coil efficiencies.

It is as such possible to manipulate power consumption through changes in cooling and heating load; e.g. through forward temperature manipulation ( $T_{fwd,cold}$ ,  $T_{fwd,hot}$ ) or through the manipulation of zone local cooling/heating ( $\dot{Q}_{act}$ ).

### III. DIRECT CONTROL USING MPC

Methods for controlling flexible consumption are often classified as either direct or indirect. For direct control, it is required by the consumer to meet a specified energy consumption in a specified time-slot[12]; this can be posed in the form of a power consumption reference signal,  $P_{ref}(t)$ , which the consumer has to track. Indirect control is based on an incentive signal, e.g. a price signal, where the intent is to provide motivation to shift loads to periods with e.g. low price.

We consider how we can employ optimal control to enable direct control of power consumption, in order to provide a general load-shifting flexibility service. Market-wise, such a service could as an example be traded intra-day in the Nordic *regulating power market*; selling upwards or downwards regulating power for a specific hour[12] up to 45 min before the delivery hour.

In posing an optimal control problem, it is possible to include equality constraints on certain variables. Thus, it is possible to include time-dependent equality constraints on power consumption, for load-shifting through direct control. One common form of employing optimal control, is by solving an optimal control problem with a receding horizon, resulting in Model Predictive Control.

#### A. Model Predictive Control

For discretized and linear system dynamics, a general MPC problem can be formulated as:

$$\min_{\mathbf{u}} J = \sum_{k=n}^{n+H} l(k, \mathbf{x}(k), \mathbf{u}(k), \mathbf{y}(k)) \quad (12)$$

subject to:

$$\mathbf{x}(k+1) = \mathbf{A} \mathbf{x}(k) + \mathbf{B} \mathbf{u}(k) \quad (\text{dynamics})$$

$$\mathbf{y}(k) = \mathbf{C} \mathbf{x}(k) + \mathbf{D} \mathbf{u}(k) \quad (\text{output})$$

state, input and output constraints:

$$\mathbf{x}_{\min} \leq \mathbf{x}(k) \leq \mathbf{x}_{\max}$$

$$\mathbf{u}_{\min} \leq \mathbf{u}(k) \leq \mathbf{u}_{\max}$$

$$\mathbf{y}_{\min} \leq \mathbf{y}(k) \leq \mathbf{y}_{\max}$$

where  $n$  is the current sample number / iteration number,  $l$  is a function mapping from states ( $\mathbf{x} \in \mathbb{R}^{n_x}$ ), inputs ( $\mathbf{u} \in \mathbb{R}^{n_u}$ ) and outputs ( $\mathbf{y} \in \mathbb{R}^{n_y}$ ) to  $\mathbb{R}$ . We choose  $l$  depending on the objective of the control law.

We include our time-dependent power consumption constraint, including time-shifting to compensate for the receding horizon:

$$P(k) = P_{\text{ref}}(k-n) \quad \text{for } n_{\text{on}} \leq k+n \leq n_{\text{off}} \quad (13)$$

Or in the form of an energy constraint:

$$\sum_{k=n_{\text{on}}-n}^{n_{\text{off}}-n} P(k) = \sum_{k=n_{\text{on}}-n}^{n_{\text{off}}-n} P_{\text{ref}}(k) \quad (14)$$

Given linear model dynamics, linear constraints,  $l$  convex and assuming a feasible solution exists, the solution found via Linear Programming methods is guaranteed to be optimal. To adhere to the power/energy constraints, the prediction horizon,  $H$ , has to be set long enough for the controller to act on the constraints and shift the load.

## IV. CASE-STUDY: KOLDING STORCENTER

Kolding Storcenter is one of two Danish shopping centers investigated in the SEBUT project [9].

#### A. HVAC setup

The HVAC system in Kolding Storcenter is made up of several HVAC hubs, with a layout similar to the one described in **Section II**. Each hub supplies a number of shops with cooling or heating, through temperature regulated air blown into the shops through fan coil units. The air is delivered from a central ventilation unit at an almost constant temperature and flow, during opening hours.

The fan coil units contain both a cooling and a heating coil, supplied with cold and hot water. Water flows through the coils are determined by electronically controlled valves. Valve opening is determined by local temperature controllers. The local temperature controllers receive setpoints through a central Building Management System (BMS) system. Local temperature controllers run with a sample time of 1 min.

For demonstration purposes, a single hub consisting of a ventilation unit and a chiller is considered – together with three of the shops they supply. The shop layout, together with their division in thermal zones is given in **Figure 3**.

#### B. System Integration

To facilitate sensor and actuator needs, we piggyback on the BMS by interfacing with the existing BMS network through the use of a *gateway unit*. Using this approach, already existing measurements and actuator signals are made available. The gateway unit allows for remote access through an Internet connection, allowing the more advanced control algorithms to be executed in e.g. a cloud-environment. The gateway unit operates with a sample time of 5 min while the BMS operates with a sample time of 1 min. A diagram sketching the approach, is given in **Figure 2**.

Possible input signals for manipulation through the BMS include (not exclusively) setpoints for supply temperature,  $T_{\text{supply},r}$ , and setpoints for the forward temperature to the chiller (CCU),  $T_{\text{fwd},\text{cold},r}$ . Measurements available include  $T_{\text{shop}}$ ,  $T_{\text{supply}}$  and  $T_{\text{fwd},\text{cold}}$ . It is not possible to manipulate fan speed for the shop fan coil units, given that the HVAC setup in Kolding Storcenter is Constant Air Volume (CAV)-based and not Variable Air Volume (VAV).

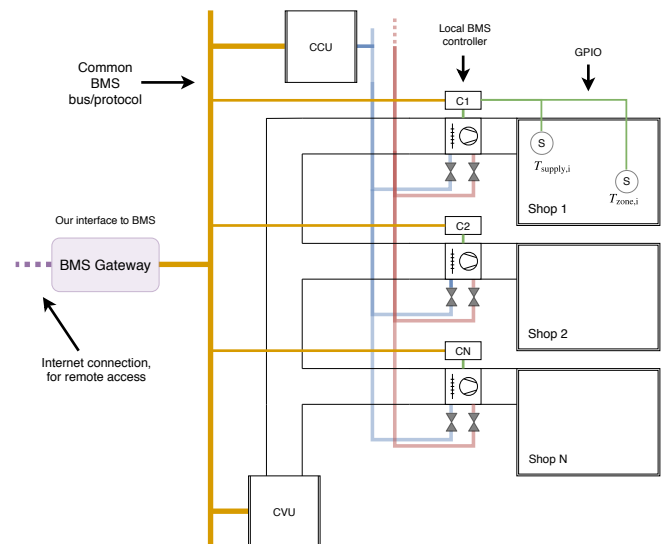

Fig. 2. The demo-zone in Kolding Storcenter, depicting the BMS network and how it is used through a gateway unit, to re-purpose already existing sensor measurements and actuator inputs for our control purposes.

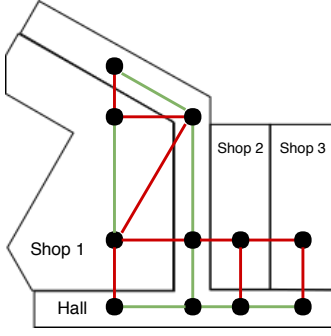

Fig. 3. The demo-zone in Kolding Storcenter, consisting of three shops. Black dots denote thermal zones. The hallway area has been discretized into several thermal zones, to model thermal interaction across hallways. The different colors exemplify different thermal resistances between thermal zones.

### C. Model instantiation

Generation of a model instance for the demo-zone in Kolding Storcenter consists of constructing the graph-representation of the thermal zones, as overlaid in **Figure 3** – and selecting suitable parameters for the dynamical model. A parameter set consists of thermal capacitances, thermal resistances and parameters specific to the fan coils (valves, coils). These can be obtained to a large extent through air flow measurements, shop dimensions and table-lookup – this process and the resulting parameters are described in [10]. Selected parameters are given in **Table I**. The large internal heat gains,  $\dot{Q}_{\text{int}}$ , are dominated by display lighting; characteristic to shopping centers. The state, input and output vectors are given as:

$$\mathbf{x} = [\mathbf{T}_{\text{shop}}, \mathbf{T}_{\text{supply}}, \mathbf{T}_{\text{hall}}, T_{\text{fwd,cold}}, \mathbf{x}_{\text{aux}}]^T \quad (15)$$

$$\mathbf{u} = [\mathbf{T}_{\text{supply,r}}, T_{\text{fwd,cold,r}}]^T \quad (16)$$

$$\mathbf{y} = [\dot{Q}_{\text{cool}}, \text{COP}, P_{\text{cool}}]^T \quad (17)$$

where  $\mathbf{x}_{\text{aux}}$  denotes auxiliary states in connection to local temperature controllers.

Note that this particular model instance of Kolding Storcenter only considers cooling, given that parameters have been identified using measurements obtained under summer-like conditions. Also specific to this model instance is the added power consumption aspects, given in (10). For this paper  $\eta_{\text{cool}} = 0.6$  has been selected, to model the efficiency from Central Cooling Unit (CCU) to cooling capacity available at the shops. Also, a COP model is introduced, to model a dependency on ambient temperature and forward temperature:

$$\text{COP}(\Delta T) = 6.66 - 0.36 \text{ K}^{-1} \Delta T + 0.007 \text{ K}^{-2} \Delta T^2 \quad (18)$$

$$\Delta T = T_{\text{amb}} - T_{\text{fwd,cold}} \quad (19)$$

This particular COP model is based on data from the CCU product catalog and COP relationship with temperature difference as described in [13]. Power measurements are needed to obtain a more realistic model.

TABLE I  
SELECTED MODEL PARAMETERS

Shop	Area [m <sup>2</sup> ]	$C_{\text{zone}}$ [kJ/K]	$C_{\text{act}}$ [kJ/K]	$\dot{Q}_{\text{int}}$ [kW]
Shop 1 (1)	500	$3 \times 10^3$	$0.75 \times 10^3$	13.0
Shop 1 (2)	500	$3 \times 10^3$	$0.75 \times 10^3$	13.5
Shop 2	250	$1.5 \times 10^3$	$0.375 \times 10^3$	5.75
Shop 3	250	$1.5 \times 10^3$	$0.375 \times 10^3$	6.75

### D. MPC

We formulate the case-specific MPC as follows:

$$\min_{\mathbf{T}_{\text{supply,r}}, T_{\text{fwd,cold,r}}} J = \sum_{k=n}^{n+H} \|x(k)\|_2 + \|u(k)\|_2 \quad (20)$$

subject to:

$$\mathbf{x}(k+1) = \mathbf{A} \mathbf{x}(k) + \mathbf{B} \mathbf{u}(k) \quad (\text{dynamics})$$

$$\mathbf{y}(k) = \mathbf{C} \mathbf{x}(k) + \mathbf{D} \mathbf{u}(k) \quad (\text{output})$$

state constraints:

$$20^\circ\text{C} \leq \mathbf{T}_{\text{shop}}(k) \leq 25^\circ\text{C}$$

$$10^\circ\text{C} \leq \mathbf{T}_{\text{supply}}(k) \leq 20^\circ\text{C}$$

input constraints:

$$10^\circ\text{C} \leq \mathbf{T}_{\text{supply,r}}(k) \leq 20^\circ\text{C}$$

$$5^\circ\text{C} \leq T_{\text{fwd,cold,r}}(k) \leq 25^\circ\text{C}$$

output constraints:

$$P(k) = P_{\text{ref}}(k-n) \quad \text{for } n_{\text{on}} \leq k+n \leq n_{\text{off}} \quad (21)$$

We choose a cost function, which is quadratic in the states and inputs, to minimize deviations from the operating point in which our model is linearized; thereby minimizing discrepancies between our nonlinear and linear model. Other options could include terms to either also minimize power consumption or maximize COP, but this is not within the scope of this paper.

Sample time for MPC has been chosen as 5 min and the prediction horizon has been chosen as 5 h; giving  $H = 60$ . The nonlinear model of the temperature dynamics for the Kolding Storcenter demo-zone has been linearized around an operating point corresponding to nominal values with summer weather conditions. Furthermore, the linear model has been discretized with the MPC sample time of 5 min.

## V. CASE-STUDY SIMULATIONS

Simulations of the proposed direct control solution for load-shifting has been conducted, simulating 5 h, during opening hours of shops in Kolding Storcenter. Given the relatively short time-frame, ambient temperature is assumed constant.

The nonlinear model is used for simulations, holding the control inputs constant for each MPC sample. Simulations have been done using Python and SciPy[14], employing CVXPY[15] for MPC.

For a first simulation, the following continuous-time power constraint is employed:

$$P_{\text{cool}}(t) = 12.5 \text{ kW} \quad \text{for } 12 \text{ h} \leq t \leq 13 \text{ h} \quad (22)$$

Given a nominal power consumption,  $P_{\text{nominal}}$  of  $\approx 19.5$  kW, the intended behavior is that load is shifted to before this interval, by pre-cooling the shops. This will allow the shop temperatures to drift towards their upper limit within the interval of restricted power consumption. This is exactly what happens, as can be seen from the simulation response in **Figure 4a**.

As seen, the use of forward temperature reference as control input, means that a higher COP is achieved during the interval of low power consumption. This in principle allows for larger power curtailments, as more cooling capacity is obtainable from the same power input. This does, however, also mean that there is room left for energy efficiency improvements during nominal operations.

Some drawbacks are apparent. First, the power consumption constraint is violated, by using more power than given in the constraints; approximately 1 kW more. This is due to the discrepancy between the linear model employed in MPC and the nonlinear model used for simulations. Second, the load-shifting induces a large spike in power consumption, just before the period of low power consumption. This spike is not desirable, given exactly the reasons why load-shifting is investigated – to avoid strain on the power grid.

For a second simulation, the following continuous-time energy constraint is employed:

$$\int_{12\text{h}}^{13\text{h}} P_{\text{cool}}(t) - P_{\text{nominal}} dt = -7\text{ kWh} \quad (23)$$

where  $P_{\text{nominal}}(t)$  is the nominal power consumption. The intent of this constraint is to shift the consumption of 7 kWh energy.

To pose this constraint, we augment our model with a new state,  $E$ :

$$\Delta \dot{E} = P_{\text{cool}}(t) - P_{\text{nominal}} \quad (24)$$

The constraint can then be formulated as:

$$\Delta E(13\text{h}) - \Delta E(12\text{h}) = -7\text{ kWh} \quad (25)$$

The simulation results with this constraint is given in **Figure 4b**. The most notable take-away, comparing the use of a power constraint to the use of an energy constraint, is that using the energy constraint introduces integral-action to the MPC that eliminates the discrepancy in energy consumption between linear and nonlinear model – and so the constraint is not violated when simulating with the nonlinear model.

In the simulations, it is possible to shift a load of approximately 7 kW for 1 h, without violating specified comfort constraints, as the shop temperatures are kept above 21 °C and below 24.5 °C. Knowing that the CCU responsible for supplying demo-zone is rated with a cooling capacity of 186 kW and that the total cooling capacity for Kolding Storcenter as 3500 kW, the results can be extrapolated as:

$$P_{\text{curtail,1h,total}} = 7\text{ kW} \frac{3500\text{ kW}}{186\text{ kW}} = 131\text{ kW} \quad (26)$$

Considering that the example simulations do not exploit the entire comfort band, the potential power curtailment for Kolding Storcenter is thus on the order of 100 kW for 1 h, using the approach outlined in this paper.

## VI. CONCLUSIONS

This paper has introduced a general control scheme for providing energy flexibility in the form of general load-shifting, by considering time-dependent constraints on either power consumption or energy consumption in MPC. The control scheme applies to buildings with centralized climate control and is applicable to a Danish shopping center, as demonstrated in the presented case-study.

The scheme considers direct control of power/energy consumption, through a reference signal. Employing a constraint on power consumption suffered steady-state errors, given discrepancies between the linear prediction model and nonlinear simulation model. Several methods are available to deal with such steady-state errors – but a possibility is also to employ nonlinear models for prediction. The steady-state errors were however avoided using constraints on energy consumption.

The approach shows a significant potential power curtailment on the order of 100 kW, for the shopping center considered, for a period of 1 h. A more thorough flexibility characterization is however needed to further verify these results – also, models for power consumption require measurements to be verified. This is scheduled as future work in the present project, where also a practical demonstration is planned.

## ACKNOWLEDGMENT

This research is funded by the SEBUT project under ForskeI/EUDP grant no. 2016-1-12555.[9]

## REFERENCES

- [1] International Energy Agency. *Energy Policies of IEA Countries - Denmark 2017 Review*. Tech. rep. 2017.
- [2] A. Arteconi, N. J. Hewitt, and F. Polonara. “State of the art of thermal storage for demand-side management”. In: *Applied Energy* 93 (2012), pp. 371–389. DOI: 10.1016/j.apenergy.2011.12.045.
- [3] Yongjun Sun et al. “Peak load shifting control using different cold thermal energy storage facilities in commercial buildings: A review”. In: *Energy Conversion and Management* 71 (2013), pp. 101–114. DOI: 10.1016/j.enconman.2013.03.026.
- [4] Pierluigi Siano. “Demand response and smart grids - A survey”. In: *Renewable and Sustainable Energy Reviews* 30 (2014), pp. 461–478. DOI: 10.1016/j.rser.2013.10.022.
- [5] Benjamin Biegel et al. “Sustainable reserve power from demand response and fluctuating production - Two Danish demonstrations”. In: *Proceedings of the IEEE*. Vol. 104. 4. 2016, pp. 780–788. DOI: 10.1109/JPROC.2016.2520698.

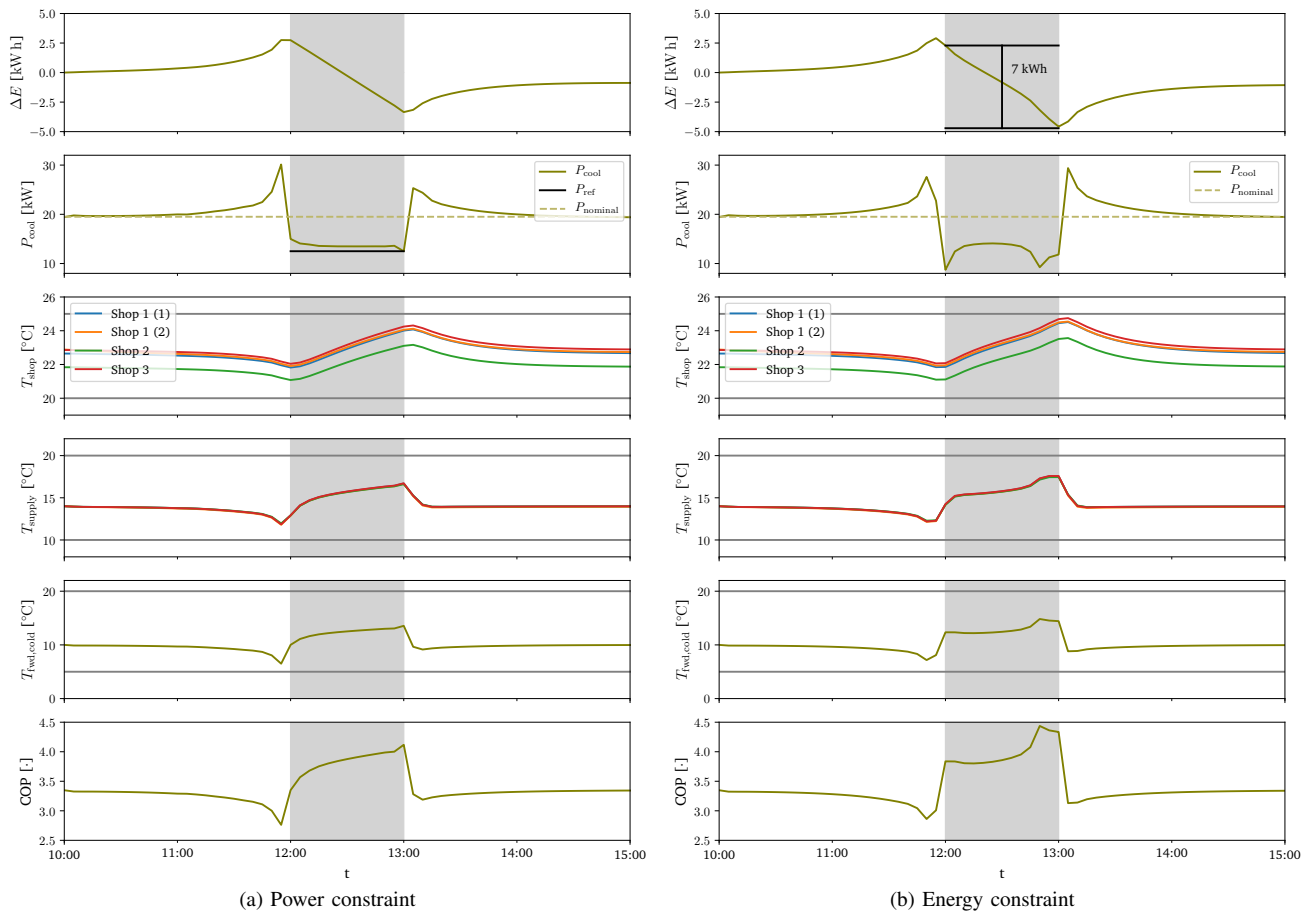

Fig. 4. MPC simulations providing load-shifting through direct control of power consumption. Two different constraints are used, to enforce load-shifting – a constraint on power consumption (a) and a constraint on energy consumption (b). Shaded-area shows interval where load is to be reduced and grey lines indicate min/max. values. Both constraints provide load-shifting, as the MPC cools down shops in due time, to let shop temperatures drift and thereby exploit the temperature comfort band for reduced power/energy consumption. The system return to nominal conditions, when the time-dependent constraints are no longer active. Using a power consumption constraint suffers from the discrepancy between linear and nonlinear model, giving a steady-state error, given the offset to power reference. This is eliminated by using an energy constraint, due to integral action.

- [6] Mehdi Maasoumy et al. “Model Predictive Control Approach to Online Computation of Demand-Side Flexibility of Commercial Buildings HVAC Systems for Supply Following”. In: *2014 American Control Conference (2014)*, pp. 1082–1089.
- [7] Samira Rahnama et al. “Services to the Distribution Grid : Experimental Verification”. In: *Ieee Transactions on Control Systems Technology* 25.2 (2016), pp. 1–11. DOI: 10.1109/TCST.2016.2563385.
- [8] Samira Rahnama et al. “Robust Aggregator Design for Industrial Thermal Energy Storages in Smart Grid”. In: *IEEE Transactions on Smart Grid* 8.2 (2017), pp. 902–916. DOI: 10.1109/TSG.2015.2481822.
- [9] SEBUT. *SEBUT*. URL: <http://sebut.teknologisk.dk/> (visited on 01/02/2018).
- [10] Joakim Børllum Petersen, Jan Dimon Bendtsen, and Jakob Stoustrup. “Multi-Zone Modeling and Energy Efficient Control of Shopping Center Cooling”. In: *Proceedings of the 2nd IEEE Conference on Control Technology and Applications*. 2018.
- [11] Bojan Mohar et al. “The Laplacian spectrum of graphs”. In: *Graph theory, combinatorics, and applications* 2.871-898 (1991), p. 12.
- [12] Benjamin Biegel et al. “Value of flexible consumption in the electricity markets”. In: *Energy* 66 (2014), pp. 354–362. ISSN: 03605442. DOI: 10.1016/j.energy.2013.12.041.
- [13] Iain Staffell et al. “A review of domestic heat pumps”. In: *Energy and Environmental Science* 5.11 (2012), pp. 9291–9306. DOI: 10.1039/c2ee22653g.
- [14] Eric Jones, Travis Oliphant, Pearu Peterson, et al. *SciPy: Open source scientific tools for Python*. 2018. URL: <http://www.scipy.org/> (visited on 01/02/2018).
- [15] Steven Diamond and Stephen Boyd. “CVXPY: A Python-Embedded Modeling Language for Convex Optimization”. In: *Journal of Machine Learning Research* 17.83 (2016), pp. 1–5.