



Aalborg Universitet

AALBORG UNIVERSITY  
DENMARK

## Autonomous power management for interlinked AC-DC microgrids

Nutkani, Inam Ullah; Meegahapola, Lasantha ; Andrew, Loh Poh Chiang ; Blaabjerg, Frede

*Published in:*  
CSEE Journal of Power and Energy Systems

*DOI (link to publication from Publisher):*  
[10.17775/CSEJJPES.2016.01510](https://doi.org/10.17775/CSEJJPES.2016.01510)

*Publication date:*  
2018

*Document Version*  
Publisher's PDF, also known as Version of record

[Link to publication from Aalborg University](#)

*Citation for published version (APA):*  
Nutkani, I. U., Meegahapola, L., Andrew, L. P. C., & Blaabjerg, F. (2018). Autonomous power management for interlinked AC-DC microgrids. *CSEE Journal of Power and Energy Systems*, 4(1), 11-18.  
<https://doi.org/10.17775/CSEJJPES.2016.01510>

### General rights

Copyright and moral rights for the publications made accessible in the public portal are retained by the authors and/or other copyright owners and it is a condition of accessing publications that users recognise and abide by the legal requirements associated with these rights.

- ? Users may download and print one copy of any publication from the public portal for the purpose of private study or research.
- ? You may not further distribute the material or use it for any profit-making activity or commercial gain
- ? You may freely distribute the URL identifying the publication in the public portal ?

### Take down policy

If you believe that this document breaches copyright please contact us at [vbn@aub.aau.dk](mailto:vbn@aub.aau.dk) providing details, and we will remove access to the work immediately and investigate your claim.

# Autonomous Power Management for Interlinked AC-DC Microgrids

Inam Ullah Nutkani, *Senior Member, IEEE*, Lasantha Meegahapola, *Senior Member, IEEE*,  
Loh Poh Chiang Andrew, *Senior Member, IEEE*, and Frede Blaabjerg, *Fellow, IEEE*

**Abstract**—The existing power management schemes for interlinked AC-DC microgrids have several operational drawbacks. Some of the existing control schemes are designed with the main objective of sharing power among the interlinked microgrids based on their loading conditions, while other schemes regulate the voltage of the interlinked microgrids without considering the specific loading conditions. However, the existing schemes cannot achieve both objectives efficiently. To address these issues, an autonomous power management scheme is proposed, which explicitly considers the specific loading condition of the DC microgrid before importing power from the interlinked AC microgrid. This strategy enables voltage regulation in the DC microgrid, and also reduces the number of converters in operation. The proposed scheme is fully autonomous while it retains the plug-and-play features for generators and tie-converters. The performance of the proposed control scheme has been validated under different operating scenarios. The results demonstrate the effectiveness of the proposed scheme in managing the power deficit in the DC microgrid efficiently and autonomously while maintaining the better voltage regulation in the DC microgrid.

**Index Terms**—Autonomous control, distributed control, droop control, hybrid microgrids, interlinked microgrids, power management.

## I. INTRODUCTION

THE technical advancement in power electronics is playing an important role in the deployment of renewables and alternative energy technologies [1]–[3] which have so far been widely realized in different forms of network topologies and configurations [4], [5]. Similarly, they have been controlled and managed using various control strategies and architectures [6], [7]. Their network topologies and control strategies are mainly determined to maximize the benefits while meeting the load requirements. At present, renewable and alternative energy technologies are widely deployed in microgrids. The deployment of these new technologies in the form of a microgrid is preferred due to several advantages,

such as optimal utilization of resources, improved power quality and enhanced supply reliability [8]–[10]. Recently, more advanced grid architectures have emerged including the zone-based grid architectures [11], multi-microgrids [12]–[15], interlinked AC-AC microgrids [16], [17] and interlinked AC-DC microgrids [18]–[22]. The main objective of these advanced network architectures is to exploit maximum benefits from renewables and alternative energy resources. For example, by interconnecting two or more microgrids, it will enable reserve sharing, support voltage and frequency, and ultimately enhance the overall reliability and resilience of interlinked microgrids.

The interlinking arrangement between two or more microgrids or with utility grids primarily depends on the overall objectives, as well as the control and management scheme used in individual microgrids. The microgrids can be interlinked directly or through harmonizing tie-converters. The harmonizing tie-converters are primarily used when two or more microgrids have different operating voltages and/or frequencies. The tie-converters are also essential if the microgrids to be interlinked have different control strategies and the power flow among them needs to be regulated [16]. Similarly, the interlinking of the DC microgrid with the utility grid or another AC microgrid also requires tie-converters to regulate the power flow among other functionalities, and that has been investigated under various scenarios in the published literature [18]–[22]. In [18], the demand-droop control has been proposed for the interlinking or tie-converters of the AC-DC microgrids. The power flow action is determined based on the normalized terminal voltage and frequency of the droop controlled interlinked AC-DC microgrids. This scheme enables autonomous power transfer between two interlinked microgrids based on their relative loading condition. The power flow decision based on the relative loading may cause the interlinking converter to operate continuously, and thus it may result in unnecessary operational losses. The same power sharing scheme has been extended to interlinked microgrids with a storage system [19]. This scheme is further improved with the progressive auto-tuning to minimize the energy flow through interlinking converters [20]. The proposed auto-tuning enables the power transfer only when one microgrid is heavily-loaded, and another microgrid is lightly-loaded. The droop based power sharing concept has been further investigated for different operating conditions of the interlinked AC and DC microgrids in [21]. In [22], the power management strategy is presented for a three-port system comprising AC, DC and a storage network. The decision about the power sharing is based on the loading con-

Manuscript received October 20, 2016; revised April 13, 2017; accepted May 31, 2017. Date of publication March 30, 2018; date of current version December 27, 2017.

I. U. Nutkani (corresponding author, e-mail: inam.nutkani@rmit.edu.au), and L. Meegahapola are with the School of Engineering, Royal Melbourne Institute of Technology (RMIT), Melbourne 3000, Australia.

L. P. Chiang A. is with the Department of Electronics Engineering, The Chinese University of Hong Kong, Shatin, N.T., Hong Kong, China.

F. Blaabjerg is with the Department of Energy Technology, Aalborg University, Aalborg, Denmark.

DOI: 10.17775/CSEEJPES.2016.01510

dition of the interlinked networks which is principally the same as presented in [20]. In addition, a communication based multilevel supervisory control is proposed to reduce the operation of interlinking converters. Another power management scheme presented in [23] for the interlinked AC-DC microgrid has an objective to regulate the voltage of the DC microgrid without taking into consideration the specific loading level of the generators. This scheme can be implemented only at a single tie-converter, hence limits the plug-n-play feature. In addition, a few centralized power management schemes have been investigated for interlinked AC-DC microgrids [24], [25]. The key concern with the centralized schemes is the reliability associated with the fast communication links. Therefore, the decentralized schemes are usually preferred.

So far the published decentralized power sharing schemes for interlinked AC-DC microgrids are either entirely based on droop principle or voltage regulation. The droop based power sharing schemes transfer power based on relative loading of the interlinked microgrids. The power transfer during a contingency or uneven loading condition supports the voltage and frequency but does not regulate the voltage and/or frequency of the interconnected microgrids. However, these schemes enable plug-n-play feature for the interlinking converters. With this feature, in case there is more than one interlinking converter, all converters will operate regardless of the overall power transfer requirement. This may incur unnecessary converter operational losses. Contrarily, the voltage regulation schemes regulate the voltage of the DC microgrid without considering specific loading conditions of the generators, and lacks the plug-n-play feature for tie-converters. These shortcomings can be specifically addressed using the proposed control scheme in this paper.

The proposed autonomous power management scheme for interlinked AC-DC microgrids takes into consideration the specific loading condition of the generators, and transfers power from AC to DC microgrid during its peak-load demand, and also regulates the voltage of the DC microgrid. The proposed scheme enables the plug-n-play feature for tie-converters and reduces the number of converters in operation to avoid unnecessary losses. In the considered scenario, the DC microgrid has inadequate generation capacity due to the high variability of the loads and renewable generation. The AC microgrid is considered to have regulated voltage and frequency as well as the surplus power to transfer to the DC microgrid during its peak demand or contingency condition. To achieve the features discussed above, a hybrid droop and voltage regulation mode control has been proposed for the tie-converters in interlinked AC-DC microgrids. The proposed control scheme relies on the tie-converter terminal voltage information to determine the overall loading condition of the droop-controlled DC microgrid. Based on the set loading threshold, the tie-converter starts automatically and transfers power to the DC microgrid during the peak-load demand or contingency condition in the DC microgrid. With the proposed hybrid control mode, the voltage of the DC microgrid is regulated at a defined nominal level. In addition, the proposed scheme allows interfacing more than one tie-converters, but as opposed to the existing scheme where all tie-converters operate

simultaneously regardless of the power transfer demand, the subsequent tie-converter only activates once the first converter power capacity has been saturated. The proposed scheme is fully autonomous with enhanced features.

## II. CONTROL OF AC AND DC MICROGRIDS

The considered DC microgrid includes a non-dispatchable generator (solar-PV) and dispatchable generators (microturbine, fuel-cell) and loads, as shown in Fig. 1. The non-dispatchable-solar PV system is set to operate in current control mode and thus extracts maximum power at all the times. The dispatchable generators are typically used for firming the renewable capacity and can be controlled either through a centralized or decentralized control scheme. The decentralized droop scheme is the most widely used and preferred, as it is simple and reliable. Therefore, the traditional droop (P-V) scheme has been used for the dispatchable generators of the DC microgrid (see Fig. 1), which is given by

$$\begin{aligned} V_{dc,ref,i} &= V_{dc,max} - \partial_{dc,i} P_{dc,i} \\ \partial_{dc,i} &= \frac{V_{dc,max} - V_{dc,min}}{P_{dc,max,i}} = \frac{\Delta V_{dc}}{P_{dc,max,i}} \end{aligned} \quad (1)$$

where,  $i$  is the DC generator number ( $i = 1, 2, 3, \dots$ );  $V_{dc,ref,i}$  is the reference voltage of  $i^{\text{th}}$  generator;  $P_{dc,i}$  is the output power of  $i^{\text{th}}$  generator;  $V_{dc,max}$  and ( $V_{dc,min} = V_{dc,nom,TC1}$ ) are the defined maximum and minimum voltage;  $P_{dc,max,i}$  is the maximum or rated power of  $i^{\text{th}}$  generator; and  $\partial_{dc,i}$  is the droop gain of  $i^{\text{th}}$  generator.

Based on (1), the voltage reference for the droop controlled generators 1 and 2 can be calculated by (2) and (3). As generators 1 and 2 share common DC bus voltage (i.e.,  $V_{dc,ref,1} = V_{dc,ref,2}$ ), (2) and (3) can be equated and rewritten by (4), which demonstrates that the droop controlled generator will share proportional power according to their rated power capacity.

$$V_{dc,ref,1} = V_{dc,max} - \partial_{dc,1} P_{dc,1} \quad (2)$$

$$V_{dc,ref,2} = V_{dc,max} - \partial_{dc,2} P_{dc,2} \quad (3)$$

$$\partial_{dc,1} P_{dc,1} = \partial_{dc,2} P_{dc,2} \rightarrow \frac{P_{dc,1}}{P_{dc,max,1}} = \frac{P_{dc,2}}{P_{dc,max,2}} = \frac{P_{dc,i}}{P_{dc,max,i}} \quad (4)$$

The equality in (4) is based on the fact that the voltage at the generator terminals is the same. Practically, the voltage at all the generator terminals is not the same due to the fact that they are connected through feeders/cables of different lengths. This voltage mismatch at the generator terminals affects the power sharing accuracy, which needs to be compensated by using any of the appropriate compensation methods [26], [27]. The droop equation with compensation of the feeder voltage drop can be rewritten by

$$V_{dc,ref,i} = V_{dc,max} - \partial_{dc,i} P_{dc,i} + i_{dc,i} X_i. \quad (5)$$

The voltage of the droop controlled DC microgrid will vary with the changing load, but within the defined permissible range. For the considered DC microgrid, the voltage range with increased aggregated loading is shown in Fig. 1 (bottom-left). For the droop controlled generators, the voltage range is

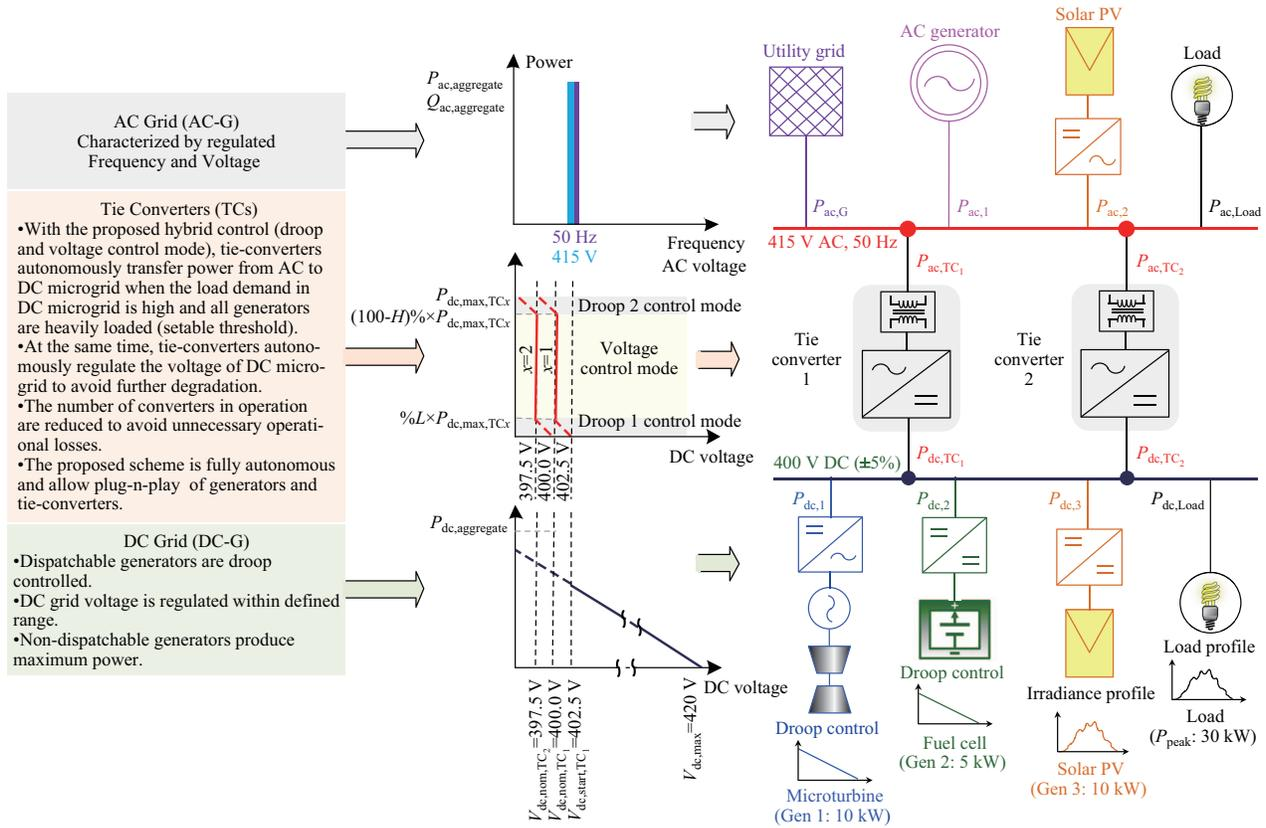

Fig. 1. Interlinked AC-DC microgrids and their control strategy.

set between 395 V and 420 V, indicating that the generators will deliver no-power at 420 V and 100% power at 395 V. Once the DC generators are heavily loaded (e.g.,  $\leq 402.5$  V at 80% generators loading), the tie-converters will start to import power from the AC microgrid to meet the peak load demand, and also regulate the voltage of the DC microgrid.

For the example of interlinked microgrids in Fig. 1, the voltage and frequency of the AC microgrid is considered stiff. The AC microgrid can be droop controlled with secondary voltage and frequency regulation, or operating in grid-connected mode. The characteristics of the AC microgrid are shown in Fig. 1, where the voltage and frequency are constant at nominal value (e.g., 50 Hz and 415 V). In addition, the AC microgrid has sufficient generation capacity to meet its local demand and export surplus power to the DC microgrid which has been demonstrated through the proposed autonomous control of the tie-converters. The details of the tie-converters control are given in Section III.

### III. PROPOSED HYBRID CONTROL OF TIE-CONVERTERS

The power rating of dispatchable generators or storage systems for firming the renewable capacity depends on the variability of the renewable source and loads in the microgrid. The high variability of renewables and loads requires dispatchable generators or storage systems with a high power rating, which may or may not be a viable solution. Alternatively, the microgrid with inadequate generation capacity could be interconnected with another microgrid or utility grid,

directly or through harmonizing converters. The tying of a DC microgrid with a AC microgrid or utility grid is only possible through tie-converters, as shown in Fig. 1. In the proposed interlinked system, the AC microgrid is characterized as a regulated voltage and frequency system with adequate generation capacity, whereas the DC microgrid is characterized as a droop controlled system with inadequate generation capacity due to the high variability of the renewable and loads. During the peak demand or the low renewable power output, the power deficit in the DC microgrid is managed by importing power from the AC microgrid. Ideally, it can be achieved efficiently and autonomously with the proposed control of the tie-converters.

In summary, the control scheme of the tie-converters is developed based on the following objectives: 1) To transfer power from the AC to DC microgrid during the peak load demand or generation contingency in the DC microgrid; 2) To minimize the power transfer losses, e.g., tie-converter should operate only during the peak-load demand in the DC microgrid, and the number of tie-converters in operation should be based on power transfer demand; 3) To regulate the voltage of the droop controlled DC microgrid; 4) To achieve fully autonomous control without depending on the communication network; 5) To enable the plug-n-play feature for tie-converters and generators.

Unlike the existing schemes for the interlinked AC-DC microgrids [18]–[22], a hybrid droop and voltage regulation mode control is proposed for the tie-converters and the mathematical form of the proposed control scheme is given by:

$$\begin{aligned}
V_{dc,ref,TCx} = & \begin{cases} \text{Off}; \\ V_{dc,start,TCx} - \delta_{L,TCx} \times P_{dc,TCx}; \\ V_{dc,nom,TCx}; \\ V_{dc,nom,TCx} - \delta_{H,TCx} [P_{dc,TCx} - (100-H)\% \times P_{dc,max,TCx}]; \end{cases} \\
& \begin{cases} V_{dc} > V_{dc,start,TCx} \\ 0 \leq P_{dc,TCx} \leq L\% \times P_{dc,max,TCx} \\ L\% \times P_{dc,max,TCx} < P_{dc,TCx} < (100-H)\% \times P_{dc,max,TCx} \\ (100-H)\% \times P_{dc,max,TCx} \leq P_{dc,TCx} \leq P_{dc,max,TCx} \end{cases} \quad (6)
\end{aligned}$$

where  $TCx$  represents the tie-converter number ( $x = 1, 2, 3..$ );  $V_{dc}$  is the DC microgrid voltage;  $V_{dc,ref,TCx}$  is the reference voltage of  $x^{th}$  tie-converter;  $V_{dc,start,TCx}$  is the threshold voltage to start of  $x^{th}$  tie-converter;  $V_{dc,nom,TCx}$  is the nominal voltage to be regulated by  $x^{th}$  tie-converter;  $P_{dc,TCx}$  is the DC power output of  $x^{th}$  tie-converter;  $P_{dc,max,TCx}$  is the maximum power limit of  $x^{th}$  tie-converter;  $L\%$  and  $H\%$  are the percentage of tie-converter rated power allocated for droop1 and 2 mode, respectively;  $V_{dc,nom,TCx+1}$  is the DC microgrid voltage when  $x^{th}$  tie-converter transfers maximum power;  $\delta_{L,TCx} = (V_{dc,start,TCx} - V_{dc,nom,TCx}) / (L\% \times P_{dc,max,TCx})$  is the droop 1 gain (at low power) of  $x^{th}$  tie-converter;  $\delta_{H,TCx} = (V_{dc,nom,TCx} - V_{dc,nom,TCx+1}) / (H\% \times P_{dc,max,TCx})$  is the droop 2 gain (at high power) of  $x^{th}$  tie-converter.

As shown in Fig. 1, tie-converter 1 starts in droop 1 control mode when the voltage in the DC microgrid drops to the set threshold of  $V_{dc,start,TCx}$ . This voltage threshold implies that all the generators in the DC microgrid are heavily-loaded (e.g. over 80% loaded). The start of the tie-converter in the droop control mode enables a smooth transition to the voltage regulation mode at the set condition i.e.,  $P_{dc,TCx} > L\% \times P_{dc,max,TCx}$ . During the voltage regulation mode, the tie-converter imports power from the AC microgrid to meet the DC microgrid peak power demand as well as regulate its voltage to be set to the nominal value of  $V_{dc,nom,TCx}$ .

Furthermore, unlike the parallel operation of all tie-converters in the existing schemes, the converters operation has been prioritized. The first tie-converter only starts when all the generators in the DC microgrid are heavily-loaded. Once the first tie-converter power capacity is near to saturation at  $P_{dc,TCx} = (100 - H)\% \times P_{dc,max,TCx}$ , its control mode is changed from the voltage regulation to droop 2 control mode to allow minor voltage drop. This minor voltage drop caused by the droop 2 control mode will enable the next tie-converter to start its operation. In case of failure of the first tie-converter, the second tie-converter will automatically start its operation followed by the voltage drop due to high load demand. Therefore, the proposed control strategy ensures efficient operation during all operating conditions without compromising the inherited flexibility of the droop based scheme. The allocation of the tie-converter's power for droop 1 and droop 2 control mode depends on the chosen value of  $L\%$  and  $H\%$  which are user definable, and should be tuned to allow smooth transition between different modes while considering the voltage and power measurement tolerance/errors in the considered microgrid.

With the proposed voltage regulation mode, the overall voltage regulation performance of the DC microgrid can be improved. In particular during the peak load demand, the

voltage of the DC microgrid is regulated at the nominal value, which is not the case with the existing power management schemes for interlinked microgrids. The performance of the proposed scheme has been validated for different load operating scenarios, as described in Section IV.

#### IV. PERFORMANCE VALIDATION

The performance of the proposed scheme has been validated for two different scenarios of the DC microgrid. In the first scenario, the microgrid comprises a dispatchable microturbine (Gen 1), fuel cell (Gen 2) and variable load. In the second scenario, a non-dispatchable solar PV generator (Gen 3) is added to scenario 1. The system parameters are summarized in Tables I–III.

TABLE I  
CONTROL MODE OF DC AND AC MICROGRIDS

Entity	Control Mode	
AC microgrid	Islanded-microgrid with regulated voltage and frequency Grid-connected mode	
Tie-converter	Hybrid droop and voltage control mode	
DC microgrid	Dispatchable generators	Droop controlled
	Non-dispatchable generators	Current control mode with MPPT

TABLE II  
DC MICROGRID PARAMETERS

Description	Parameter	Value
Voltage	$V_{dc}$ (V)	400 (+5%, -1.25%)
Micro-turbine	$P_{dc,max,1}$ (kW)	10
	$\partial_{dc,1}$ (V/kW)	2.5
Fuel cell	$P_{dc,max,2}$ (kW)	5
	$\partial_{dc,2}$ (V/kW)	5
Solar PV	$P_{dc,max,3}$ (kW)	10
Load	$P_{Load,peak}$ (kW)	25

TABLE III  
AC MICROGRID AND TIE CONVERTER PARAMETERS

Description	Parameter	Value
AC microgrid	$V_{ac}$ (V)	415 ( $l-l$ )
	$f$ (Hz)	50
Tie-converter	$P_{dc,max,TC1}$ (kW)	10
	$V_{dc,start,TC1}$ (V)	402.5
	$V_{dc,nom,TC1}$ (V)	400.0
	$V_{dc,nom,TC2}$ (V)	397.5
	$L\% = H\%$	10%

The mode transition logic of the tie-converter is given in the logic flow diagram shown in Fig. 2, and the detailed control block diagram of the tie-converter is shown in Fig. 3. Both scenarios have been tested at different load operating conditions to demonstrate the robustness and effectiveness of the proposed scheme.

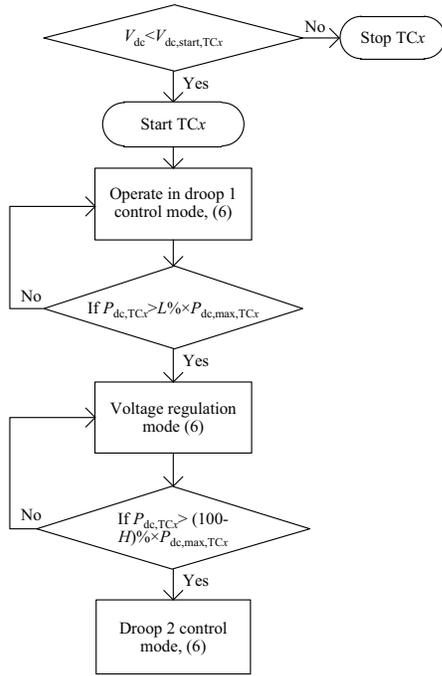

Fig. 2. Logic flow diagram showing mode transitions of tie-converter.

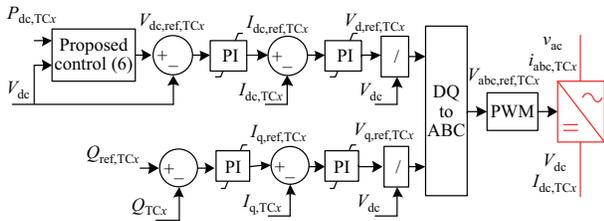

Fig. 3. Control block diagram of tie-converter.

A. Scenario 1: DC Microgrid with Variable Load

The DC microgrid comprises microturbine ( $P_{dc,max,1} = 10$  kW), fuel cell ( $P_{dc,max,2} = 5$  kW) and variable DC load ( $P_{Load,peak} = 20$  kW) and it is interlinked with the AC microgrid through a tie-converter ( $P_{dc,max,TC1} = 10$  kW), as shown in Fig. 4.

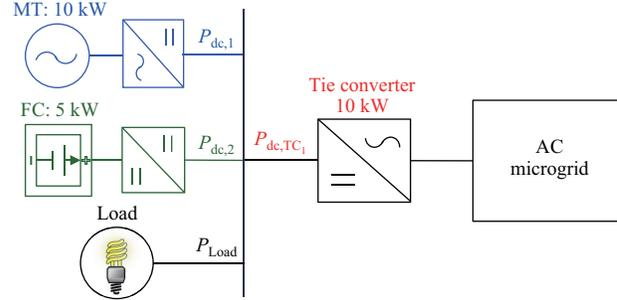

Fig. 4. Scenario 1: DC microgrid with microturbine, fuel cell and load.

The load in the DC microgrid is varied in steps from 5 kW to 20 kW (i.e. 5 kW  $\rightarrow$  10 kW  $\rightarrow$  15 kW  $\rightarrow$  20 kW  $\rightarrow$  10 kW). At the 15 kW load demand, the expected loadings of generator 1 and generator 2 are more than 80%, and the voltage of the DC microgrid is below the set threshold of  $V_{dc,start,TC1} = 402.5$  V. This condition will enable the tie-converter 1 to import power from the AC microgrid and regulate the voltage of the DC microgrid at the defined nominal value of  $V_{dc,nom,TC1} = 400.0$  V. This expected performance can be witnessed from the results shown in Fig. 5. At the highlight point 1, at 8 s, the voltage of the DC microgrid decreases below 400 V followed by the step load change from

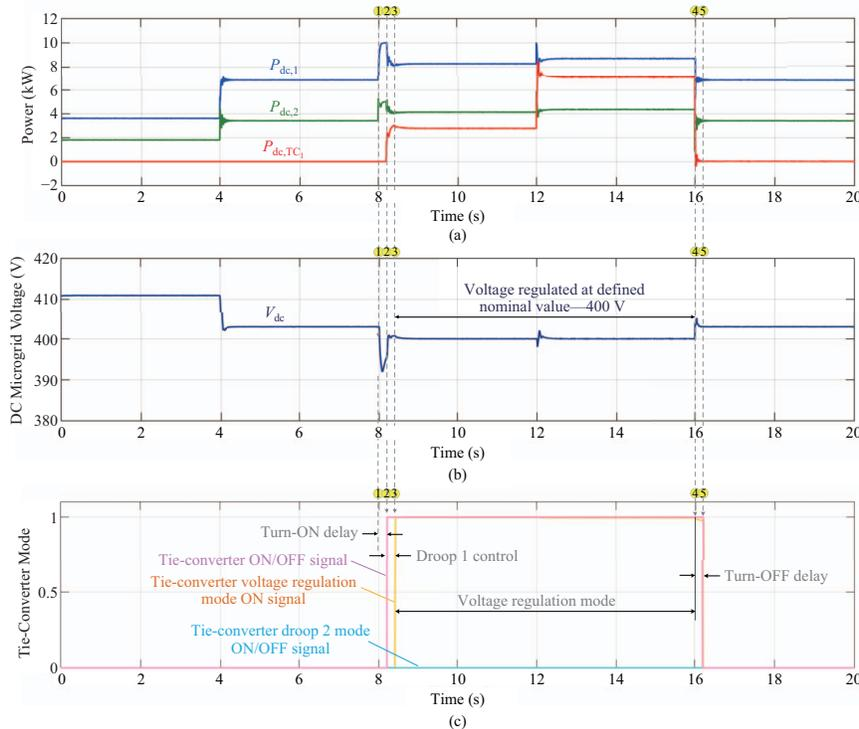

Fig. 5. Scenario 1: Results showing (a) generators and tie-converter power, (b) DC microgrid voltage and (c) tie-converter control signals for four different load operating conditions.

10 kW to 15 kW. This voltage drop triggers tie-converter 1 to start in droop 1 control mode at point 2. After starting in droop 1 control mode, the tie-converter control mode is immediately transitioned to the voltage regulation mode at point 3, since the set threshold ( $P_{dc,TC_1} > 10\% \times P_{dc,max,TC_1}$ ) is satisfied. At 12 s, the load in the DC microgrid is further increased from 15 kW to 20 kW, and the power transferred from the AC microgrid is increased accordingly. Throughout the peak-load demand in the DC microgrid from 8 s to 12 s, tie-converter 1 remains operational and regulates the voltage of the DC microgrid. Once the load demand in the DC microgrid is decreased at the highlighted point 4, at 16 s, the tie-converter turns off automatically after a short delay at point 5, as shown in Fig. 5. As demonstrated, tie-converter 1 only operates once all the DC generators are heavily loaded. During its operation, the voltage in the DC microgrid is regulated to the defined nominal value of 400 V. Therefore the proposed strategy has better voltage regulation performance and ensures efficient operation.

**B. Scenario 2: DC Microgrid with Non-dispatchable Generator and Load Profile**

A non-dispatchable generator–solar PV system is added to scenario 1, as shown in Fig. 6. The power output of

the solar PV system is based on a continuously varying irradiance profile. The load in scenario 2 also has a varying profile with a peak demand of 25 kW. This test scenario is developed to further demonstrate the effectiveness of the proposed strategy for various practical operating conditions of renewable generation and load demand.

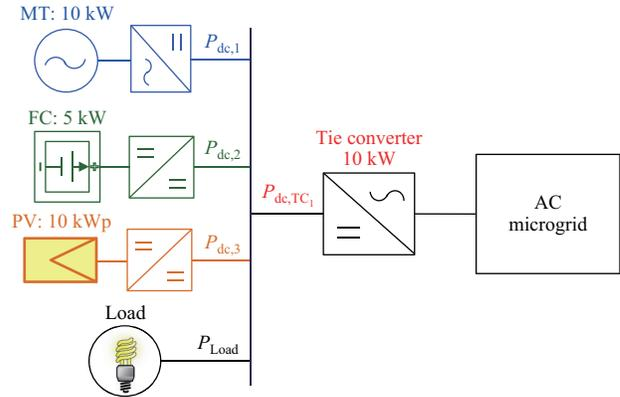

Fig. 6. Scenario 2: DC microgrid with microturbine, fuel cell, solar PV and load.

The load in the DC microgrid increases gradually to the peak value 24.5 kW, and then decreases, as shown in Fig. 7(a).

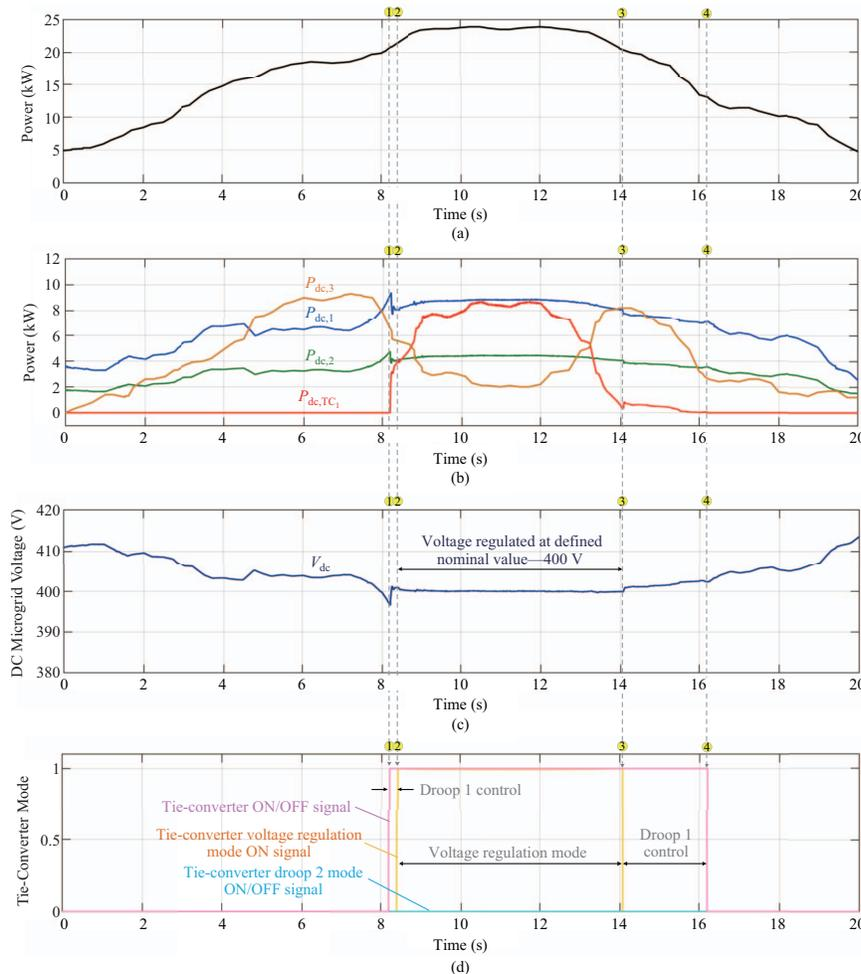

Fig. 7. Scenario 2: Results showing (a) DC microgrid load demand, (b) generators and tie-converter power, (c) DC microgrid voltage and (d) tie-converter control signals at varying solar PV and load operating conditions.

The loading on the DC generators increases with the increasing load demand. At the highlight point 1, the loading on generator 1 and generator 2 exceeds 80% and the voltage of the DC microgrid drops below the set threshold of  $V_{dc,start,TC_1} = 402.5$  V when the load demand is very high and the solar PV output is less. In agreement with the proposed control, tie-converter 1 starts at highlighted point 1 and imports power from the AC microgrid to overcome the power deficit in the DC microgrid while regulating its voltage. Tie-converter 1 operates in the voltage regulating mode from point 2 at 8.5 s to point 3 at 14.2 s. From point 3 and onward, the load in the DC microgrid decreases such that the tie-converter power output is below  $10\% \times P_{dc,max,TC_1}$  and this condition requires the tie-converter to operate in the droop 1 control mode before it turns off at highlighted point 4 at 16.4 s. From point 4 and onward, the load demand in the DC microgrid is less than the generation, hence it can be met by the local generators. As expected, it has been demonstrated that the tie-converter only operates during the power deficit in the DC microgrid. In addition, the voltage of the DC microgrid is also regulated by importing power from the AC grid. This behavior depicts the grid-connected mode of the AC microgrid but through a tie-converter.

## V. CONCLUSION

An autonomous power management scheme has been presented for interlinked AC-DC microgrids having different configurations. The proposed scheme manages the power deficit in the DC microgrid efficiently and autonomously. The number of tie-converters in operation has been reduced with the proposed prioritization to avoid unnecessary operational losses. The scheme has demonstrated better voltage regulation in the DC microgrid. The performance and robustness of the proposed scheme have been validated for two different scenarios of the DC microgrid at variable load conditions.

## REFERENCES

- [1] J. Rocabert, A. Luna, F. Blaabjerg, and P. Rodríguez, "Control of power converters in AC microgrids," *IEEE Transactions on Power Electronics*, vol. 27, no. 11, pp. 4734–4749, Nov. 2012.
- [2] M. Liserre, T. Sauter, and J. Y. Hung, "Future energy systems: integrating renewable energy sources into the smart power grid through industrial electronics," *IEEE Industrial Electronics Magazine*, vol. 4, no. 1, pp. 18–37, Mar. 2010.
- [3] M. Tsili and S. Papathanassiou, "A review of grid code technical requirements for wind farms," *IET Renewable Power Generation*, vol. 3, no. 3, pp. 308–332, Sep. 2009.
- [4] T. Strasser, F. André, J. Kathan, C. Cecati, C. Buccella, P. Siano, P. Leitão, G. Zhabelova, V. Vyatkin, P. Vrba, and V. Mařík, "A review of architectures and concepts for intelligence in future electric energy systems," *IEEE Transactions on Industrial Electronics*, vol. 62, no. 4, pp. 2424–2438, Apr. 2015.
- [5] A. Kwasinski, "Quantitative evaluation of dc microgrids availability: Effects of system architecture and converter topology design choices," *IEEE Transactions on Power Electronics*, vol. 26, no. 3, pp. 835–851, Mar. 2011.
- [6] P. Basak, S. Chowdhury, S. H. N. Dey, S. P. Chowdhury, "A literature review on integration of distributed energy resources in the perspective of control, protection and stability of microgrid," *Renewable and Sustainable Energy Reviews*, vol. 16, no. 8, pp. 5545–5556, Oct. 2012.
- [7] D. E. Olivares, A. Mehrizi-Sani, A. H. Etemadi, C. A. Canizares, R. Iravani, M. Kazerani, A. H. Hajimiragha, O. Gomis-Bellmunt, M. Saeedifard, R. alma-Behnke, G. A. Jimenez-Estevez, and N. D. Hatziaargyriou, "Trends in microgrid control," *IEEE Transactions on Smart Grid*, vol. 5, no. 4, pp. 1905–1919, Jul. 2014.
- [8] N. Hatziaargyriou, H. Asano, R. Iravani, and C. Marnay, "Microgrids," *IEEE Power and Energy Magazine*, vol. 5, no. 4, pp. 78–94, Jul. /Aug. 2007.
- [9] L. E. Zubieta, "Are microgrids the future of energy?: DC microgrids from concept to demonstration to deployment," *IEEE Electrification Magazine*, vol. 4, no. 2, pp. 37–44, Jun. 2016.
- [10] G. Venkataramanan and C. Marnay, "A larger role for microgrids," *IEEE Power and Energy Magazine*, vol. 6, no. 3, pp. 78–82, May-Jun. 2008.
- [11] W. Yuan, J. H. Wang, F. Qiu, C. Chen, C. Q. Kang, and B. Zeng, "Robust optimization-based resilient distribution network planning against natural disasters," *IEEE Transactions on Smart Grid*, vol. 7, no. 6, pp. 2817–2826, Nov. 2016.
- [12] N. Nikmehr, S. N. Ravadanegh, "Optimal power dispatch of multi-microgrids at future smart distribution grids," *IEEE Transactions on Smart Grid*, vol. 6, no. 4, pp. 1648–1657, Jul. 2015.
- [13] H. Farzin, M. Fotuhi-Firuzabad, M. Moeini-Aghtaie, "Enhancing power system resilience through hierarchical outage management in multi-microgrids," *IEEE Transactions on Smart Grid*, vol. 7, no. 6, pp. 2869–2879, Nov. 2016.
- [14] J. Wu, X. H. Guan, "Coordinated multi-microgrids optimal control algorithm for smart distribution management system," *IEEE Transactions on Smart Grid*, vol. 4, no. 4, pp. 2174–2181, Dec. 2013.
- [15] N. Hatziaargyriou, "Operation of multi-microgrids," in *Microgrids: Architectures and Control*, Wiley-IEEE Press, 2014.
- [16] I. U. Nutkani, P. C. Loh, and F. Blaabjerg, "Distributed operation of interlinked AC microgrids with dynamic active and reactive power tuning," *IEEE Transactions on Industry Applications*, vol. 49, no. 5, pp. 2188–2196, Sep. /Oct. 2013.
- [17] I. U. Nutkani, P. C. Loh, and F. Blaabjerg, "Power flow control of intertied AC microgrids," *IET Power Electronics*, vol. 6, no. 7, pp. 1329–1338, Aug. 2013.
- [18] P. C. Loh, D. Li, Y. K. Chai, and F. Blaabjerg, "Autonomous operation of hybrid microgrid with AC and DC subgrids," *IEEE Transactions on Power Electronics*, vol. 28, no. 5, pp. 2214–2223, May 2013.
- [19] P. C. Loh, D. Li, Y. K. Chai, and F. Blaabjerg, "Autonomous control of interlinking converter with energy storage in hybrid AC-DC microgrid," *IEEE Transactions on Industry Applications*, vol. 49, no. 3, pp. 1374–1382, May-Jun. 2013.
- [20] P. C. Loh, D. Li, Y. K. Chai, and F. Blaabjerg, "Autonomous operation of ac-dc microgrids with minimised interlinking energy flow," *IET Power Electronics*, vol. 6, no. 8, pp. 1650–1657, Sep. 2013.
- [21] N. Eghtedarpour and E. Farjah, "Power control and management in a hybrid AC/DC microgrid," *IEEE Transactions on Smart Grid*, vol. 5, no. 3, pp. 1494–1505, May 2014.
- [22] P. Wang, C. Jin, D. X. Zhu, Y. Tang, P. C. Loh, and F. H. Choo, "Distributed control for autonomous operation of a three-Port AC/DC/DS hybrid microgrid," *IEEE Transactions on Industrial Electronics*, vol. 62, no. 2, pp. 1279–1290, Feb. 2015.
- [23] X. Liu, P. Wang, and P. C. Loh, "A hybrid AC/DC microgrid and its coordination control," *IEEE Transactions on Smart Grid*, vol. 2, no. 2, pp. 278–286, Jun. 2011.
- [24] M. N. Ambia, A. Al-Durra, and S. M. Mueeen, "Centralized power control strategy for AC-DC hybrid micro-grid system using multi-converter scheme," in *Proceedings of the 37th Annual Conference on IEEE Industrial Electronics Society*, 2011, pp. 843–848.
- [25] A. A. A. Radwan and Y. A. R. I. Mohamed, "Bidirectional power management in hybrid AC-DC islanded microgrid system," in *Proceedings of 2014 IEEE PES General Meeting*, 2014, pp. 1–5.
- [26] I. U. Nutkani, W. Peng, P. C. Loh, and F. Blaabjerg, "Autonomous economic operation of grid connected DC microgrid," in *Proceedings of the 5th International Symposium on Power Electronics for Distributed Generation Systems (PEDG)*, 2014, pp. 1–5.
- [27] I. U. Nutkani, W. Peng, P. C. Loh, and F. Blaabjerg, "Cost-based droop scheme for DC microgrid," in *Proceedings of 2014 IEEE Energy Conversion Congress and Exposition (ECCE)*, 2014, pp. 765–769.



**Inam Ullah Nutkani** (SM'14) received a B.E. degree in electrical engineering from the NED University of Engineering and Technology, Karachi, Pakistan in 2003, and M.S. and Ph.D. degrees in Electrical Power Engineering from the Nanyang Technological University, Singapore, in 2007 and 2014, respectively. He has been working in different domains of power system with power utilities, regulators, industry and research organizations including K-Electric Karachi, NESCOM Islamabad, West Energy, Singapore, JM Pang & Seah Singapore and

Experimental Power Grid Centre (EPGC), A\*STAR Singapore, during 2003 to 2016. Currently he is a Lecturer at the School of Engineering, Royal Melbourne Institute of Technology (RMIT), Melbourne, Australia. His fields of professional expertise and interest include renewable, distributed generation and microgrids, power electronics and control, and next generation electricity grids.



**Lasantha Meegahapola** (M'11–SM'17) received his B.E. degree in electrical engineering (First Class) from the University of Moratuwa, Sri Lanka in 2006, and his Ph.D. degree from Queen's University of Belfast, UK in 2010. His doctoral study was based on the investigation of power system stability issues with high wind penetration, and research was conducted in collaboration with EirGrid (Republic of Ireland-TSO). In addition, he conducted extensive research studies on coordinated reactive power dispatch during steady-state and dynamic/transient

conditions for networks with high wind penetration. He was a visiting researcher in the Electricity Research Centre, University College Dublin, Ireland (2009/2010). From 2011 to 2014 he was employed as a Lecturer at the University of Wollongong (UOW) and continues as an Honorary Fellow at UOW. He is currently employed as a Lecturer at Royal Melbourne Institute of Technology (RMIT) Melbourne, Australia. He is a senior member of the IEEE and IEEE Power Engineering Society (PES).



**Poh Chiang Loh Andrew** (M'04) received his B.E. degree (Hons) and M.E. degree from the National University of Singapore in 1998 and 2000 respectively, and his Ph.D. degree from Monash University, Australia, in 2002, all in electrical engineering. After his studies, he has worked for 10 years as an Assistant Professor, and a Tenured Associate Professor in the Nanyang Technological University, Singapore. From 2013 to 2016, he was a Tenured Full Professor at Aalborg University, Denmark. Currently, he is a Tenured Full Professor at the Department of

Electronics Engineering, the Chinese University of Hong Kong, China, and a Full Professor at the Beijing Jiaotong University, China. His research interest includes multilevel inverters, converter topological developments, converter control and modulation techniques.



**Frede Blaabjerg** (M'88–SM'97–F'03) was with ABB-Scandia, Randers, Denmark, from 1987 to 1988. From 1988 to 1992, he was a Ph.D. Student with Aalborg University, Aalborg, Denmark. He became an Assistant Professor in 1992, an Associate Professor in 1996, and a Full Professor of power electronics and drives in 1998. His current research interests include power electronics and its applications such as in wind turbines, PV systems, reliability, harmonics and adjustable speed drives. He has received 15 IEEE Prize Paper Awards, the IEEE

PELS Distinguished Service Award in 2009, the EPE-PEMC Council Award in 2010 and the IEEE William E. Newell Power Electronics Award 2014. He was an Editor-in-Chief of the IEEE Transactions on Power Electronics from 2006 to 2012. He has been a Distinguished Lecturer for the IEEE Power Electronics Society from 2005 to 2007 and for the IEEE Industry Applications Society from 2010 to 2011.