



Aalborg Universitet

AALBORG UNIVERSITY
DENMARK

Vestas Power Plant Solutions Integrating Wind, Solar PV and Energy Storage

Petersen, Lennart; Hesselbæk, Bo; Martinez, Antonio; Borsotti-Andruszkiewicz, Roberto M.; Tarnowski, German Claudio; Steggel, Nathan; Osmond, Dave

Published in:

Proceedings of the 3rd International Hybrid Power Systems Workshop

Publication date:

2018

Document Version

Publisher's PDF, also known as Version of record

[Link to publication from Aalborg University](#)

Citation for published version (APA):

Petersen, L., Hesselbæk, B., Martinez, A., Borsotti-Andruszkiewicz, R. M., Tarnowski, G. C., Steggel, N., & Osmond, D. (2018). Vestas Power Plant Solutions Integrating Wind, Solar PV and Energy Storage. In T. Ackermann, & U. Betancourt (Eds.), *Proceedings of the 3rd International Hybrid Power Systems Workshop* Energynautics.

General rights

Copyright and moral rights for the publications made accessible in the public portal are retained by the authors and/or other copyright owners and it is a condition of accessing publications that users recognise and abide by the legal requirements associated with these rights.

- ? Users may download and print one copy of any publication from the public portal for the purpose of private study or research.
- ? You may not further distribute the material or use it for any profit-making activity or commercial gain
- ? You may freely distribute the URL identifying the publication in the public portal ?

Take down policy

If you believe that this document breaches copyright please contact us at vbn@aub.aau.dk providing details, and we will remove access to the work immediately and investigate your claim.

Vestas Power Plant Solutions Integrating Wind, Solar PV and Energy Storage

Lennart Petersen^{1,3}, Bo Hesselbæk¹, Antonio Martinez¹, Roberto M. Borsotti-Andruszkiewicz¹, German C. Tarnowski¹, Nathan Steggel², Dave Osmond²

¹ Vestas Wind Systems, Denmark, ² Windlab Limited, Australia

³ Department of Energy Technology, Aalborg University, Denmark

Email: lepte@vestas.com, bohes@vestas.com, aomar@vestas.com, rombo@vestas.com, getar@vestas.com, nathan.steggel@windlab.com, david.osmond@windlab.com

Abstract— This paper addresses a value proposition and feasible system topologies for hybrid power plant solutions integrating wind, solar PV and energy storage and moreover provides insights into Vestas hybrid power plant projects. Seen from the perspective of a wind power plant developer, these hybrid solutions provide a number of benefits that could potentially reduce the Levelized Cost of Energy and enable entrance to new markets for wind power and facilitate the transition to a more sustainable energy mix. First, various system topologies are described in order to distinguish the generic concepts for the electrical infrastructure of hybrid power plants. Subsequently, the benefits of combining wind and solar PV power as well as the advantages of combining variable renewable energy sources with energy storage are elaborated. Finally, the world's first utility-scale hybrid power plant combining wind, solar PV and energy storage is presented.

Keywords: Hybrid power plant; wind power; solar photovoltaic; battery energy storage; capacity factor; annual energy production; ancillary services

I. INTRODUCTION

A general trend in the modern energy landscape is the exploitation of potentialities for combining multiple distributed energy resources (e.g. wind power, solar PV, biomass power) with energy storage as well as managing demand response with the power grid objective to balance the energy capacity and to improve power quality as well as system stability and security.

Seen from the perspective of a wind power plant (WPP) developer, these hybrid solutions provide a number of benefits that could potentially reduce the Levelized Cost of Energy (LCOE) and enable entrance to new markets for wind power and facilitate the transition to a more sustainable energy mix.

When referring to hybrid power plant (HPP) solutions with renewable energy resources, a generic definition is provided in [1]: “This is a power system, using one renewable and one conventional energy source or more than one renewable with or without conventional energy sources, that works in 'stand-alone' or 'grid-connected' mode”. While the focus of stand-alone solutions (off-grid HPPs) is exclusively laid on the satisfaction of local consumption, the on-grid HPP operates as

grid integrated power plant unit to serve the needs of the bulk power system and energy system environment.

This paper will address a value proposition and feasible system topologies for **on-grid HPPs integrating wind, solar PV and energy storage** and moreover provide insights into Vestas power plant projects that investigate the potential of hybrid solutions. First, various system configurations are described in order to distinguish the generic concepts for the electrical infrastructure of HPPs. Subsequently, the benefits of combining wind and solar PV power as well as the advantages of combining variable renewable energy sources with energy storage are elaborated. The added value for enhanced provision of ancillary services is demonstrated by the *Lem Kær* project – a WPP augmented by battery energy storage (BESS). Subsequently, the world's first utility-scale HPP combining wind, solar PV and energy storage is presented. In this specific project in Australia (*Kennedy Energy Park – Phase I*), 12 Vestas V136 wind turbines (WTGs) amounting to 43 MW installed capacity will be coupled with 15 MW of solar PV and 2 MW / 4 MWh of BESS.

The paper concludes with a summary of the key hypotheses, which are being used to develop new customer specific offerings for Vestas power plant solutions by combining these aspects.

II. HYBRID POWER PLANT CONFIGURATIONS

In the context of wind integrated HPP solutions a number of configurations is possible depending on the business case and the present energy resources. However, globally seen for a specific location only solar and wind power are always available to a certain extent. Thus, in this section the focus will be laid on the following three combinations, considering wind as the primary renewable energy source (RES) in the HPP.

- A. Wind + solar PV
- B. Wind + battery energy storage
- C. Wind + solar PV + battery energy storage

A. Co-Located Hybrid Power Plant Solutions

A *co-located* HPP is a system, where all assets have individual Points of Connection (PoCs), but are connected to the same substation, which is the interconnection point between HPP and external grid (see **Figure 1**, I.a – I.c). Here, a global plant controller needs to host functionalities to aggregate the individual assets, so that the entire system can be considered as a single power plant from the grid point of view. Today’s WPP controllers already provide this capability. However, for *co-located* HPPs they require more advanced functionalities to also host solar PV and/or BESS besides WTGs.

B. WTG-Coupled Solutions

A *WTG-coupled* system leverages on the existing conversion equipment inside the WTGs. Several coupling options are possible. The focus is laid on a *DC-coupled* system, where all assets are connected to a common DC-link. This can be done by connecting PV and / or ESS to the power converter of the WTG. **Figure 2** illustrates a *WTG-coupled* system (II.a – II.c). Here, the WTG controller needs to be capable of controlling PV and / or BESS, so that the entire system can be considered as a single generating asset from the grid point of view. In case of a power plant consisting of multiple *WTG-coupled* hybrid systems connected to an AC collector system, the global plant controller needs to consider altered (i.e more advanced) capabilities and functionalities of the individual assets.

C. DC-Coupled Hybrid Power Plant Solutions

Figure 3 (III.a – III.c) and **Figure 4** (IV.a – IV.c) illustrate a *DC-coupled* system at grid level, where the collector system is based on DC technology. Here, the individual assets are connected to a DC collector system. It is obvious that different control schemes at asset level are required as compared to traditionally AC connected assets. Moreover, additional grid

components within the HPP are identified that need to be integrated in the plant controller. In case of HVAC connected systems (**Figure 3**) a grid-side inverter (DC/AC) represents the interface between plant and grid, while in HVDC connected systems (**Figure 4**) a DC/DC converter is required to couple the plant with an HVDC grid. For larger HVAC connected HPPs, two variants of architectures are possible (not shown in the figures) - on the one hand, AC aggregation where several DC feeders are connected to the grid AC bus through individual DC/AC inverters, on the other hand DC aggregation where feeders are connected to a common DC bus and then converted to AC power through one large DC/AC inverter [2]. The control schemes and functionalities of the plant controller highly depend on the selected topology.

III. VALUE PROPOSITION OF HYBRID POWER PLANTS

A. Benefits of Combining Wind and Solar PV Power

The elaborations on the value of combining wind and PV power for grid integration refer to combination A (wind + solar PV). The following benefits are valid for all configurations, i.e. *Co-Located* and *DC-Coupled* HPPs as well as *WTG-coupled* solutions.

General

- **Increased Annual Energy Production (AEP) and capacity factor:** Combining technologies with varying power generation patterns can improve the overall combined HPP capacity factor and/or increase the overall energy output [3]. In particular, in regions with high diurnal and/or seasonal complementarity of wind and PV power a higher degree of capacity is achievable, relative to the grid connection limitation.
- **Reduced power fluctuations and gradients:** Merging wind and PV power can attenuate their individual power

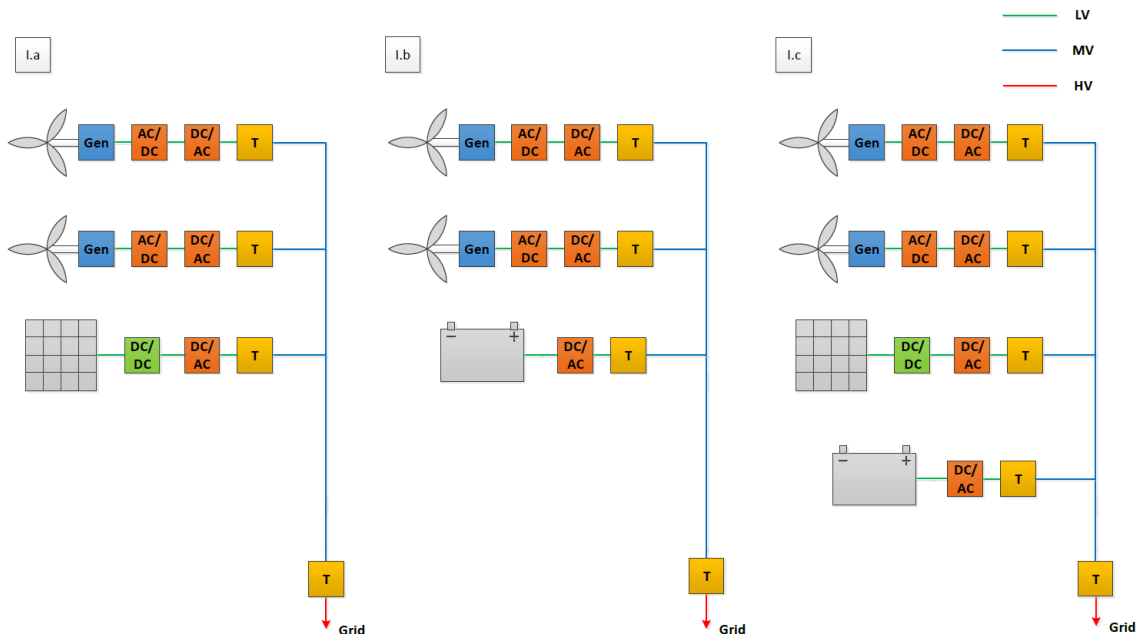

Figure 1: Configurations for Co-Located Hybrid Power Plant

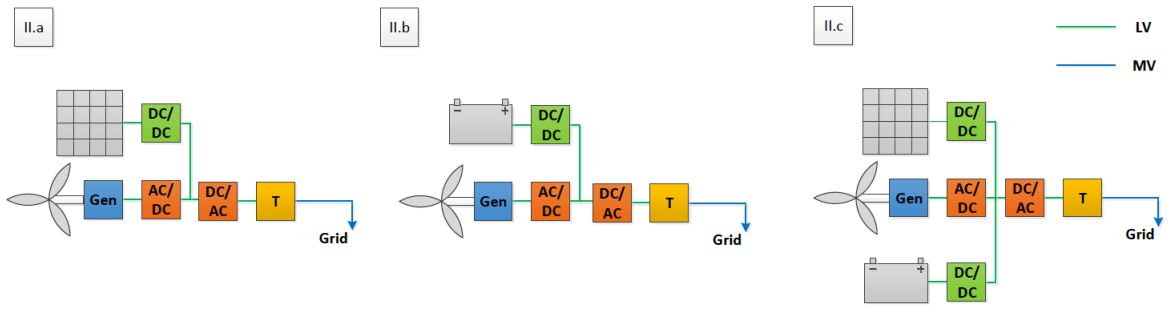

Figure 2: Configurations for *WTG-coupled* system integration

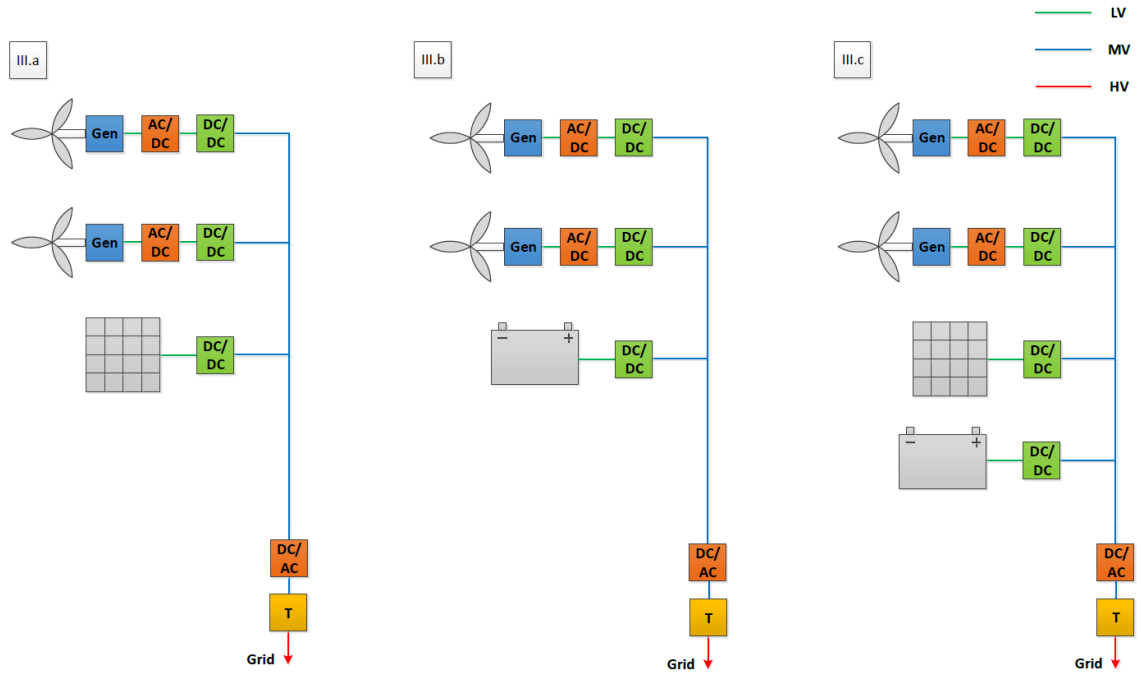

Figure 3: Configurations for *DC-coupled* Hybrid Power Plant for HVAC connection

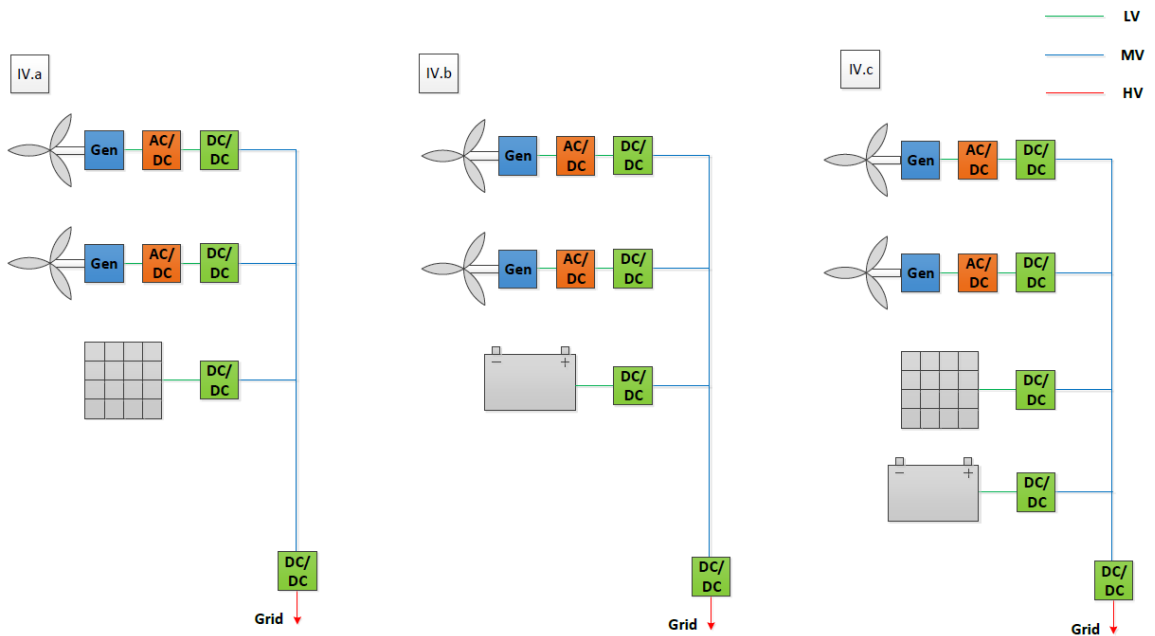

Figure 4: Configurations for *DC-coupled* Hybrid Power Plant for HVDC connection

fluctuations and thereby decrease the gradient of the overall power plant output. In this way, the demand for BESS is reduced significantly [3]. A study for wind and PV aggregation in South Africa [4] has revealed that “up to 20 to 30% energy share of variable renewable energies (wind and solar PV) for the whole country will not increase short-term (15 min) gradients or ramps significantly if there is a balanced combination of wind and solar PV in the electricity system”.

- **CAPEX reduction:** In [4] it is determined that “at least 20% overcapacity of wind and solar PV power can be installed per substation without any curtailment of wind and solar PV power”. In this way, the electrical infrastructure for the plant grid connection can be saved by aggregating wind and PV power plants.
- **OPEX reduction:** For PV systems and WTGs similar power electronic maintenance expertise is required and can be performed by the same technicians and hence reduce the OPEX cost of two separate maintenance teams.
- **License to operate and enter:** The combination of above factors can help to fulfil the increasingly complex grid codes and thereby support the customer to operate a HPP under difficult grid code conditions, enabling to operate or even enter into new markets.

The following benefits refer only to *Co-Located* HPPs (configuration I).

Co-Located Hybrid Power Plant

- **Power loss reduction:** High reactive power demand by the grid operator can potentially lead to important active power losses within the plant. Because of the low simultaneity of high levels of wind and PV power, the combination of wind and PV power offers the potential to reduce these losses and thereby increase the AEP when optimized methods for allocating reactive power are employed [5].

The following benefits refer to *DC-Coupled* HPPs (configurations III and IV) and partially to WTG-coupled systems in general (configuration II).

DC-Coupled Hybrid Power Plant

- **Further CAPEX reduction:** In *DC-coupled* systems, the CAPEX can be reduced by saving components for electricity conversion. For *WTG-coupled* systems, the WTG and PV system share a common inverter. For DC-coupling on plant level, the DC to AC electricity conversion is handled by a single inverter at substation level and not by multiple inverters on asset level.
- **Increased component utilization:** Connecting PV systems on WTG level increases the component utilization at asset level, i.e. converter and transformer. In this way, the number of full-load hours in the WTG can

be increased, as the PV system can support to achieve rated power output.

B. Benefits of Combining Variable Renewable Energy and Energy Storage

The elaborations on the value of combining renewable power and storage for grid integration refer to both combination B (wind + battery energy storage) and C (wind + solar PV + battery energy storage). The following benefits are valid for all configurations, i.e. *Co-Located* and *DC-Coupled* HPPs as well as *WTG-coupled* solutions.

General

- **Increased Annual Energy Production (AEP) and capacity factor:** The combination of complementing RES and BESS, particularly when optimized vs. the demand, can increase the AEP by storing excess energy production, which would otherwise be curtailed, from wind and PV [8]. By achieving a relatively constant power output of the plant, a higher degree of capacity is achievable seen from the PCC limitation.
- **Enhanced utilization flexibility:** In this context, access to various revenue streams can be ensured, as the HPP can be operated with high flexibility and target various energy services such as Energy Arbitrage and Demand/Load Following [8]. Energy Arbitrage refers to the separation of the instants of energy purchase and selling energy based on energy price in order to maximize the benefits. With Demand/Load Following the plant power output is adjusted according to a demand/load profile throughout the day.
- **Reduce power forecast error:** The predictability of wind or PV production depends on the quality of the weather forecast and the forecasting method. BESSs can compensate to some extent the deviations between predicted and actual power production and in this way enhance the capability of the HPP to participate in wholesale markets (Day-ahead/Intra-day) and balancing/regulating markets [9].
- **Reduced power fluctuations and gradients:** Introducing BESS can further limit the maximum gradient of wind and PV power output due to changes in wind speed and solar irradiation (Power smoothening) [8]. This is particularly important to fulfil grid code requirements, as the active power ramp rate of the HPP needs to take on specified values.
- **CAPEX reduction:** An improved capacity factor can decrease the CAPEX financing cost by assuring a higher business case certainty and reducing the project discount factor. Furthermore, the BESS can be used to capture excess energy from an “overplanted” system, where the HPP’s rated capacity is above the grid connection capacity, in this way reducing the relative CAPEX investment on the electrical Balance of Plant (eBoP) as well as on the civil Balance of Plant (cBoP).

- **OPEX reduction:** During their entire lifetime, WTGs and PV systems are subject to maintenance work which requires complete shut-down for certain time periods leading to loss of power production. With BESS, these operational costs can be reduced to a certain extent by optimized scheduling, so that the HPP is able to deliver the requested power despite a shut-down WTG and/or PV. For PV, WTG and BESS similar power electronic maintenance expertise is required and can be performed by the same technicians and hence reduce the OPEX cost of three separate maintenance teams.
- **Licence to operate and enter:** Similar as in the case of just WTG & PV, adding BESS to the HPP enables to enter into new markets, comply to grid codes and allow to capture additional revenue streams.

The following benefits refer only to *Co-Located* HPPs (configuration I).

Co-Located Hybrid Power Plant

- **Improved performance for grid code compliance and ancillary services:** BESSs fully rely on power electronic converter interface to be connected to the grid and thus have significant capability to contribute to ancillary service provision of the HPP. In this way, grid services such as black start support can be offered by storage equipped HPPs. Moreover, the ability of BESS to both ramp up and down the active power output with very fast time responses enhances the HPP capability of providing frequency support, fast frequency control and power system damping [8].

The following benefits refer to *DC-Coupled* HPPs (configurations III and IV) and partially to WTG-coupled systems in general (configuration II).

DC-Coupled Hybrid Power Plant

- **CAPEX reduction and increased component utilization:** Just like for *DC-coupled* HPPs with wind and PV, the CAPEX can be reduced by saving components for electricity conversion, when BESS and generating assets are coupled to a common DC-link. Moreover, connecting BESS on WTG level increases the component utilization at turbine level, i.e. converter and transformer. In case of *WTG-coupled* systems with solar PV, an additional BESS can further enhance the capacity utilization, so that power curtailment is avoided during high wind speed and high solar irradiation by charging of the BESS.

IV. VESTAS HYBRID POWER PLANT PROJECTS

A. Lem Kær – Wind Power Plant Augmented by Energy Storage

In 2012, the *Lem Kær* demonstration project has been established in order to quantify the value proposition of wind power combined with energy storage. The HPP consists of 4 x

3 MW WTGs, a 1.2 MW/ 300 kWh BESS and a 400 kW / 100 kWh BESS from different companies. The HPP is connected to the Danish transmission grid and the battery management system is integrated with the WPP control system (see **Figure 5**).

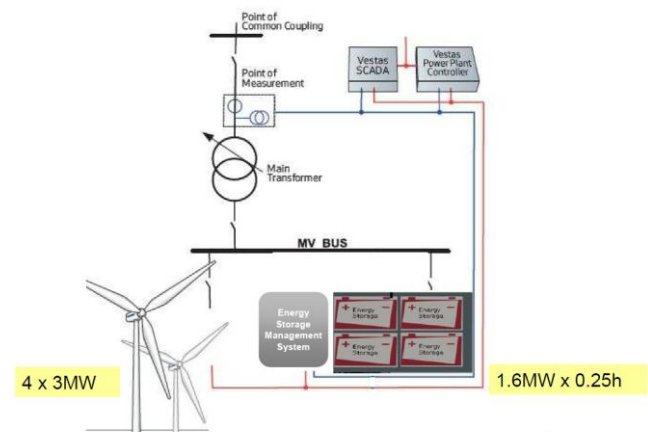

Figure 5: Project Overview – Lem Kær [10]

The *Lem Kær* demonstrator has been part of a Vestas research programme with the aim of identifying the added value of combining WPPs with energy storage.

One of the research activities has focused on the feasibility of enhanced ancillary services by HPPs, i.e. frequency support, inertial response and power oscillation damping [11]. The provision of primary frequency reserve requires an active power change of the HPP in proportion to a deviating system frequency with a response time of few seconds and duration of delivery of 15 minutes. For inertial response the active power is changed in proportion to changes of the time derivative of the system frequency (df/dt), responding within tenth's of a second. Damping of power oscillations in the second range involves an active or reactive power change in proportion to a signal representative of an oscillatory active power flow in the system [11]. **Figure 6** shows the HPP control and dispatch architecture used in the test facility, exclusively for the sake of investigating the above-mentioned ancillary services.

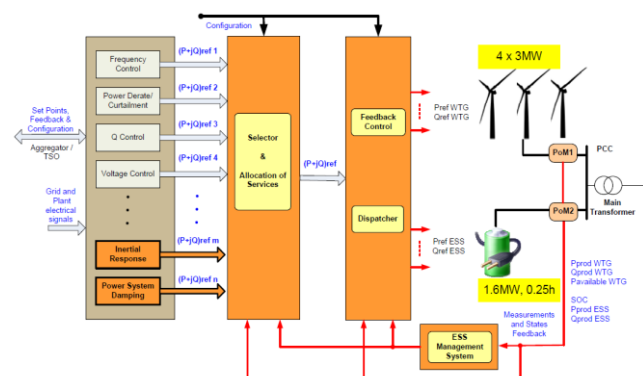

Figure 6: Hybrid Power Plant control and dispatch architecture for testing enhanced ancillary services on the *Lem Kær* demonstrator [11]

Figure 7 shows some of the test results obtained for enhanced ancillary services on the *Lem Kær* demonstrator. It is worth noting that the use case of providing primary frequency reserve has been approved by the Danish transmission system operator (TSO), enabling the HPP to participate in the primary reserve market.

Another Vestas research activity has investigated the value of energy storage in HPPs from an economical perspective. The PhD project work documented in [12] has addressed the profitability of installing BESS in order for the HPP to participate in the Danish power market (ancillary service and day-ahead market). Optimization algorithms have been developed for optimally sizing, scheduling and dispatching the BESS.

The third topic covered by the Vestas research programme has been the estimation of BESS lifetime and capacity degradation, resulting in two further PhD projects [13], [14]. Field tests have been performed using the *Lem Kær* demonstrator in order to evaluate the BESS' performance degradation and to validate models for battery ageing during realistic operation as well as to develop diagnostic tools for the BESS [15], [16].

The overall achievements and learnings by the *Lem Kær* research and demonstration project can be summarized as follows:

- Reduction in financial penalties for not meeting generation commitment
- Ramp rate reduction / power smoothing (dP/dt control)

- Improved lifetime of battery storage (rate of degradation)
- Assuring primary, secondary, tertiary reserves
- Testing of enhanced ancillary services (inertial response, power oscillation damping)
- Testing two different Lithium-Ion battery types

B. Kennedy Energy Park – Integrating Wind, Solar PV and Energy Storage

Kennedy Energy Park Phase I [17] is the world's first on-grid utility-scale HPP integrating wind, solar and storage and consists of 43 MW V136-3.6 MW turbines, 15 MW of solar PV and 2 MW/4 MWh battery storage. The project is located in Queensland, Australia, and jointly owned by Windlab Limited and Eurus Energy. The technology providers besides Vestas are SMA, Jinko Solar and Tesla (see **Figure 8**). The project is under construction under joint and several EPC contracts managed by Vestas and Quanta and will become operational during 2018.

Optimisation of the plant configuration was conducted by Windlab during the development phase and consisted of a complex process that took a number of factors into account. These included the grid connection limit of 50MW; variation of distribution and transmission network losses with energy output; half-hourly and seasonal merchant price forecasts; and, diurnal and seasonal variability of the energy resources. The optimal project configuration oversized the direct grid connection by around 20%. However, there is another solar PV project connected nearby with 18 MW (AC) installed capacity. The effective oversizing is around 50% with only a

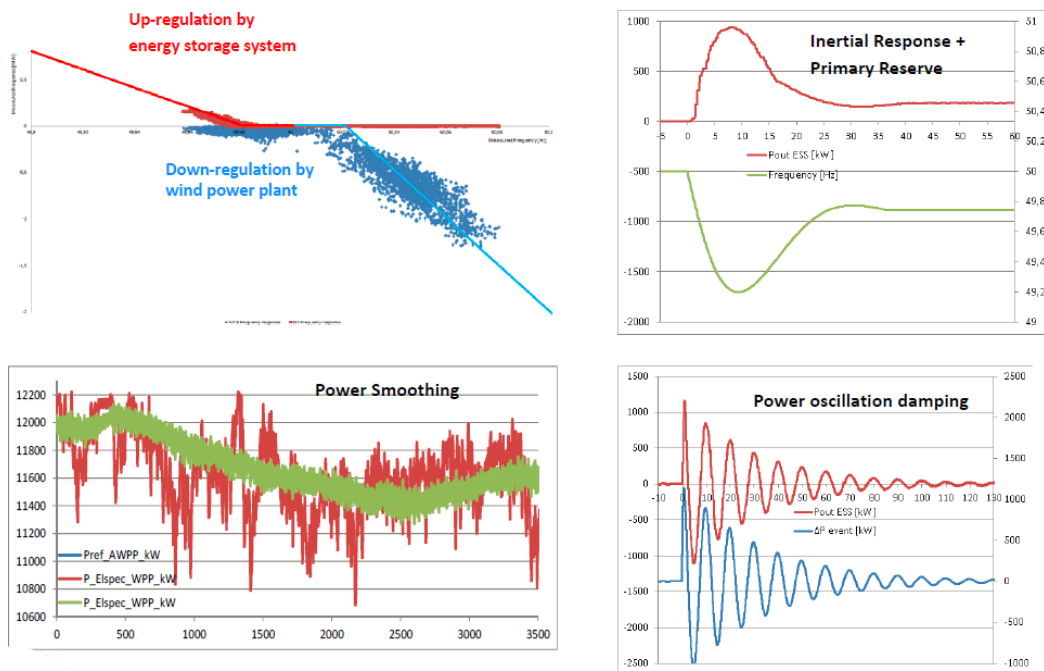

Figure 7: Test results of enhanced ancillary services by hybrid power plants (wind power + energy storage) [10]

few percent curtailment due to the strong anti-correlation between wind and solar resource at this location.

Designed as a demonstration project, *Kennedy Energy Park Phase I* can also shape a path forward for how Australia and other countries can integrate more renewable energy into their energy mix and address challenges of intermittency and electrical grid stability. *Kennedy Energy Park Phase II* (up to 1200 MW) is already under development.

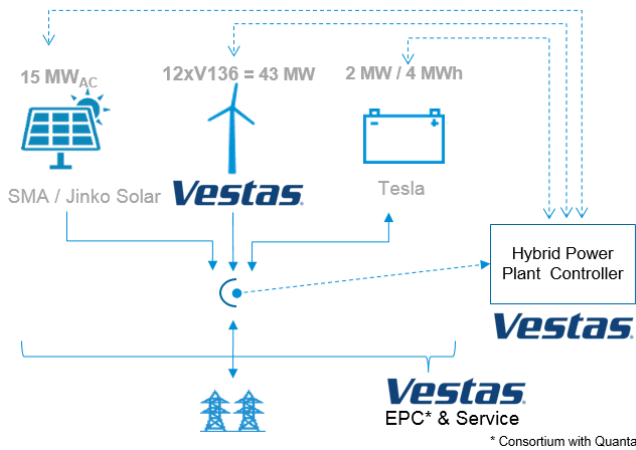

Figure 8: Project Overview - Kennedy Energy Park Phase I

The business case of **combining wind and solar PV power** in this project is given by the daily and seasonal complementarity of both variable renewable energy resources. While wind is greatest during the night, solar irradiation peaks during the day. On a monthly scale, solar peaks during the summer months when wind conditions are relatively low, while wind power generation peaks during the winter months, when solar irradiation profile is at its minimum.

The relevant use cases for **combining variable renewable energy and energy storage** to be exploited during this pilot project are curtailment reduction, energy arbitrage and frequency support:

Curtailment Reduction

Due to grid constraints, the HPP is not able to export more than 50 MW at the Point of Common Coupling (PCC). The BESS can be utilized to store parts of the generated power that would otherwise get curtailed, and release it at times when the grid has the capacity to take this spare generation.

Energy Arbitrage

Revenue is maximized by charging the BESS when the spot price is low, and then selling into the market when prices are high. The price cycles on the five-minute spot market are driven primarily by diurnal cycles. Typical variations include a late afternoon into early evening peak associated with increased demand in commercial (late afternoon) and residential (early evening) buildings. A lower amplitude demand/price peak can also be present in the morning, associated with daily start-up activities in residential and commercial buildings.

Frequency Support

Power plants providing Frequency Control Ancillary Services (FCAS) push or absorb power to or from the grid in response to the grid frequency deviations from the standard 50 Hz frequency. A BESS can perform a frequency raise service if it has capacity to release power for a certain period of time, while it can perform a frequency lower service if it has capacity to store electricity from the grid for a certain period of time.

The combined exploitation of these three use cases can be realized by daily operational schedules. During time periods of the day when the BESS is neither used for curtailment reduction nor for energy arbitrage, it will bid on the FCAS markets.

V. CONCLUSIONS AND PERSPECTIVES

As elaborated in this paper, hybrid solutions provide a number of benefits that could potentially reduce the LCOE and enable entrance to new markets for wind power, and facilitate the transition to a more sustainable energy mix. The running pilot projects, demonstrator and bespoke customer solutions aim to quantify the following 4 hypotheses, which are being used by Vestas to develop new customer specific offerings by combining these four aspects:

- **Complementarity**
Combining technologies with varying power generation patterns can improve the utilisation rate of plant infrastructure. This can result in either higher AEP through increased MW capacity or lowering infrastructure cost relative to the overall combined power plant capacity. This can prove particularly useful in case of asset related restrictions (e.g. pad restrictions, irrigation limitations, turbulences).
- **Increased business case certainty**
The combination of energy sources in hybrids have the potential to increase the predictability in the combined production (positively impacting project P value), thereby improving the business case certainty and bankability for our customers. Furthermore, the complementing energy sources may match supply and demand better. If storage is added, this match can be further improved and help avoid curtailment, or provide the opportunity to participate in additional revenue streams, such as ancillary service.
- **Synergies in development, installation and servicing costs**
Synergies may be achieved in areas such as land rights, permitting, foundations, trenching, operation and maintenance relative to MW capacity, i.e. reducing CAPEX, OPEX, DEVEX.
- **Fulfilment of grid requirement**
Combined more stable power plant energy production & deployment (storage) may fulfil grid requirements with more simplified compensation equipment. Additional

revenue streams related to ancillary services may be achievable.

- **Energy dispatchment flexibility**

With the addition of storage in a hybrid system, energy dispatchment can be shifted to more closely meet energy demands and/or take advantage of a fluctuating electricity market.

- **Improved production to demand correlation**

Even without the inclusion of storage, combining wind and solar has the potential to improve correlation to demand when compared to solar or wind individually

Two main HPP configurations are investigated to prove the stated hypotheses, i.e.

- *Co-located* integration – Assets are connected at substation level and controlled by the Power Plant Controller
- *WTG-coupled* integration – Assets are connected through the WTG power electronic interface

Two Vestas demonstration/ pilot projects for co-located hybrid solutions are presented in this paper, i.e. *Lem Kær* (wind power + energy storage) and *Kennedy Energy Park Phase I* (wind power + solar PV + energy storage). Moreover, a WTG-coupled demonstrator, combining a Vestas V112-3.0 MW WTG and 372 kW of solar PV, is currently under development.

ACKNOWLEDGMENT

The authors would like to acknowledge the support of the investors and financiers in *Kennedy Energy Park*. These are the project owners Windlab and Eurus Energy, ARENA (the Australian Renewable Energy Agency) who supported the project with a refundable grant through the Advancing Renewables Program (ARP) and the Clean Energy Finance Corporation who provided senior debt.

REFERENCES

- [1] I. Lazarov, V. D., Notton, G., Zarkov, Z., Bochev, “Hybrid power systems with renewable energy sources types, structures, trends for research and development,” *Int. Conf. ELMA2005*, pp. 515–520, 2005.
- [2] J. Pan, S. Bala, M. Callavik, and P. Sandeberg, “DC Connection of Offshore Wind Power Plants without Platform,” *13th Wind Integr. Work.*, pp. 1–6, 2014.
- [3] Y. Sawle, S. C. Gupta, B. A. Kumar, and W. Meng, “PV-wind hybrid system: A review with case study,” *Cogent Eng.*, vol. 3, no. 1, 2016.

- [4] Council for Scientific and Industrial Research (CSIR), “Wind and Solar PV Resource Aggregation Study for South Africa,” *South African Int. Renew. Energy Conf.*, no. March, 2016.
- [5] R. Grab, F. Ackermann, and S. Rogalla, “Symbiotic Operation of Large PV and Wind Power Plants,” *6th Sol. Integr. Work.*, 2016.
- [6] J. R. Gracia, S. W. Hadley, and Y. Liu, “Wind / PV Generation for Frequency Regulation and Oscillation Damping in the Eastern Interconnection (EI),” 2013.
- [7] P. Kreutzkamp *et al.*, “Ancillary Services by Solar PV - Capabilities and Costs,” 2014.
- [8] G. Huff *et al.*, “DOE/EPRI 2013 electricity storage handbook in collaboration with NRECA,” *Rep. SAND2013*, p. 340, 2013.
- [9] D. Rastler, “Electric Energy Storage Technology Options: A White Paper Primer on Applications, Costs and Benefits,” *Epri*, pp. 1–170, 2010.
- [10] S. Saylor, “Ancillary Services Provided from Wind Power Plant Augmented with Energy Storage,” 2014.
- [11] G. C. Tarnowski, P. C. Kjær, R. Lærke, and F. Iov, “Power System Stabilising Features from Wind Power Plants Augmented with Energy Storage,” *Eur. Wind Energy Conf. Exhib.*, 2013.
- [12] P. Hubert and J. Braun, *Intelligent Energy Management System for Virtual Power Plants*. 2015.
- [13] D. I. Stroe, “Lifetime models for Lithium-ion batteries used in virtual power plant applications, PhD dissertation, Aalborg University,” 2014.
- [14] M. J. Swierczynski, “Lithium ion battery energy storage system for augmented wind power plants.” Department of Energy Technology, Aalborg University, 2012.
- [15] D. Stroe, M. Swierczynski, and R. Teodorescu, “Degradation Behaviour of Lithium-Ion Batteries based on Field Measured Frequency Regulation Mission Profile,” pp. 14–21, 2015.
- [16] M. Swierczynski, D. I. Stroe, A. I. Stan, R. Teodorescu, R. Lærke, and P. C. Kjær, “Field tests experience from 1.6MW/400kWh Li-ion battery energy storage system providing primary frequency regulation service,” *2013 4th IEEE/PES Innov. Smart Grid Technol. Eur. ISGT Eur. 2013*, pp. 1–5, 2013.
- [17] N. Steggel, D. Osmond, and G. Burns, “Kennedy Energy Park Knowledge Sharing (FinClose Report),” *ARENA, Wind. Kennedy Energy Park websites*, 2018.