



Aalborg Universitet

AALBORG UNIVERSITY
DENMARK

Active Damping of Torsional Vibrations due to the Sub-harmonic Instability on a Synchronous Generator

Peyghami, Saeed; Azizi, Ali; Mokhtari, Hossein; Blaabjerg, Frede

Published in:

Proceedings of 2018 20th European Conference on Power Electronics and Applications (EPE'18 ECCE Europe)

Publication date:

2018

Document Version

Early version, also known as pre-print

[Link to publication from Aalborg University](#)

Citation for published version (APA):

Peyghami, S., Azizi, A., Mokhtari, H., & Blaabjerg, F. (2018). Active Damping of Torsional Vibrations due to the Sub-harmonic Instability on a Synchronous Generator. In *Proceedings of 2018 20th European Conference on Power Electronics and Applications (EPE'18 ECCE Europe)* (pp. 1-8). [8515662] IEEE.

<https://www.scopus.com/record/display.uri?eid=2-s2.0-85057022401&origin=inward&txGid=1ecaa0eda4122bbacb467e4b40dfd5f6>

General rights

Copyright and moral rights for the publications made accessible in the public portal are retained by the authors and/or other copyright owners and it is a condition of accessing publications that users recognise and abide by the legal requirements associated with these rights.

- ? Users may download and print one copy of any publication from the public portal for the purpose of private study or research.
- ? You may not further distribute the material or use it for any profit-making activity or commercial gain
- ? You may freely distribute the URL identifying the publication in the public portal ?

Take down policy

If you believe that this document breaches copyright please contact us at vbn@aub.aau.dk providing details, and we will remove access to the work immediately and investigate your claim.

Active Damping of Torsional Vibrations due to the Sub-harmonic Instability on a Synchronous Generator

Saeed Peyghami
Department of Energy
Technology, Aalborg
University
Aalborg 9220 East, Denmark
sap@et.aau.dk

Ali Azizi, Hossein Mokhtari,
Department of Electrical
Engineering, Sharif
University of Technology,
Tehran, Iran
aliazizi@alum.sharif.edu,
mokhtari@sharif.edu

Frede Blaabjerg
Department of Energy
Technology, Aalborg
University
Aalborg 9220 East, Denmark
fbl@et.aau.dk

Keywords

« Active filter», « Active damping», « Interharmonics», «Microgrid», «Synchronous machine»

Abstract

Sub-harmonic stability issues due to the interaction between a load-commutated motor drive and a synchronous turbo-generator train in a Liquefied Natural Gas (LNG) station are studied in this paper. The sub-harmonic current injected by motor drives may excite the mechanical torsional modes of turbo-generator train. In this paper, the electro-mechanical interaction phenomenon is investigated and an active damper is proposed to absorb the sub-harmonic currents of motor drives and increase the damping of the electro-mechanical system. Simulations and experiments validate the instability problem and effectiveness of the proposed solution.

1. Introduction

The necessity of high reliability and availability for industrial customers enforces them to install individual Distributed Generations (DGs) to support their plant. DGs can decrease the dependency of a plant on the utility grid as well as increasing the availability and efficiency of the power systems. Furthermore, microgrid technologies make an infrastructure to fulfill a reliable operation for grid-connected and islanded power systems by integrating local DGs and loads. The main challenge of a microgrid plant is to operate the system in the islanded mode especially in presence of synchronous generators and power electronic-based loads. Stability issues can significantly affect the overall system availability and hence may increase system operation costs.

Harmonic stability is the most common stability problem which Power Electronic-based Power Systems (PEPSs) are facing. So far, some research studies have been done to investigate, model and mitigate the harmonic stability in PEPS [1]–[5]. Most research studies focus on electrical resonance issues, i.e., resonance between grid lines and capacitors. Modeling techniques and passive/active mitigation methods have been presented in [1]–[3].

Aforementioned studies have been presented for power electronic based sources. However, synchronous generators, especially gas turbo-generators are still main part of industrial plants like Liquefied Natural Gas (LNG) stations. Including synchronous turbo-generators in a PEPS introduces new challenges by making interactions between power converters and conventional generators. Harmonic stability issues can be one of those problems, which is most feasible and may affect the system availability especially in the islanded mode of operation. In fact, a turbo-generator train in a synchronous generator have some mechanical torsional modes, which can be excited by any disturbance with a frequency close to the torsional frequencies. On the other hand, operating motor drives with different frequencies can induce harmonics and

sub-harmonics to the grid in some rotating speeds [6], [7]. If the injected sub-harmonics is equal to one of the torsional frequencies, the mechanical system starts vibrating. This interaction between electrical grid and mechanical system is a kind of harmonic stability in an electro-mechanical system.

The torsional interactions between a turbo-generator train and variable speed drives have been presented in some studies [8]–[10]. In [11], damping of torsional vibrations with thyristor-controlled converters have been reviewed. In [12], simulation of torsional vibrations in an LNG plant has been studied, and two solutions to overcome the torsional instability have been presented including adding a resistive load, and modifying the turbine shaft to change the natural frequencies. None of these solutions sounds to be economical or practical. In [13], an active damping circuit is presented to overcome the torsional vibrations, where the reference of the control unit is taken from the shaft torque oscillations, and its sub-harmonic components are extracted with band pass filters. Since the reference signal is driven from the mechanical signals, the dynamic response and performance of the control approach is not appropriate. In this paper, an active damper based on an adaptive active filter is proposed in order to absorb and increase the damping of the electro-mechanical vibrations. Hence, the proposed approach improves the system stability in terms of electro-mechanical interactions. In the following the stability problem and proposed solution are explained.

2. Electro-mechanical Interaction Phenomenon

The electrical network of the LNG plant in this study is shown in Fig. 1 including a 26.25-MVA synchronous gas turbo-generator and two 8 MW gas compressors with variable speed drives. Furthermore, four harmonic filter banks (5th, 7th and 2×11th harmonic filters) are connected to the compressors terminal to compensate the harmonic currents of compressor drives. Also, the plant is supplied through the utility at 63 kV. In an islanded mode, the generator must supply the active and reactive power of the compressors with higher availability.

The whole control system of the generator including excitation and governor system as well as mechanical system of turbo-generator train is completely modeled in the PSCAD/EMTDC software. The compressors drives as shown in Fig. 1 are Load Commutated Inverters (LCIs) feeding 6-phase synchronous motors. The block diagram of the compressors control system is shown in Fig. 2. The plant is modeled based on the information given in the datasheets for the generator and compressors as summarized in Table 1 and 2.

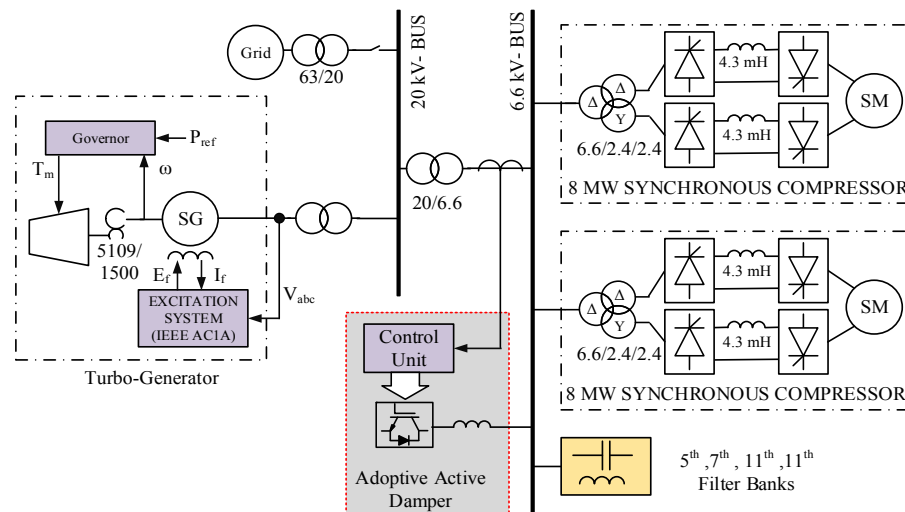

Fig. 1: Electrical grid of the studied LNG plant.

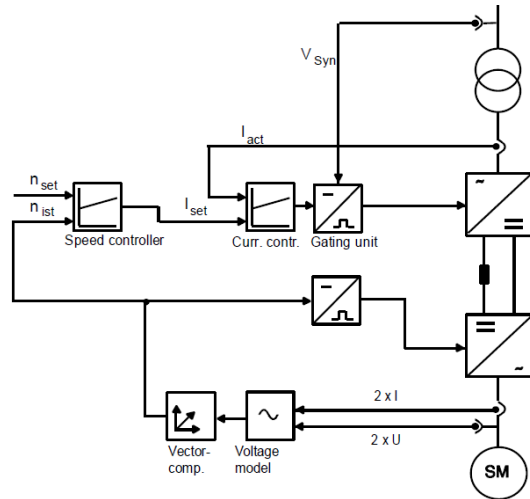

Fig. 2: Control structure of synchronous compressor drive.

Table 1: Synchronous generator electrical parameters.

Generator Parameters	Values
Rated power (MVA)	26.25
Rated line to line voltage (kV-rms)	6.35
Armature resistance (pu)	0.04
Armature time constant (s)	0.278
Unsaturated reactance [X_d] (pu)	1.65
Unsaturated transient reactance [X'_d] (pu)	0.26
Unsaturated transient time constant (open) [T'_{do}] (s)	11.073
Unsaturated sub-transient reactance [X''_d] (pu)	0.15
Unsaturated sub-transient time constant (open) [T''_{do}] (s)	0.0326
Unsaturated reactance [X_q] (pu)	1.6
Unsaturated transient reactance [X'_q] (pu)	0.223
Unsaturated transient time constant (open) [T'_{qo}] (s)	0.35
Unsaturated sub-transient reactance [X''_q] (pu)	0.159
Unsaturated sub-transient time constant (open) [T''_{qo}] (s)	0.1717

Table 2: Synchronous compressor electrical parameters.

Generator Parameters	Values
Rated power (MW)	8
Number of phases	6
Rated line to line voltage (kV-rms)	2×2.4
Speed (RPM)	1800
Stator resistance (Ω)	0.0028
Rotor resistance (Ω)	0.334
Unsaturated reactance [X_d] (pu)	0.123
Unsaturated transient reactance [X'_d] (pu)	0.013
Unsaturated transient time constant (open) [T'_{do}] (s)	2.952
Unsaturated sub-transient reactance [X''_d] (pu)	0.0075
Unsaturated sub-transient time constant (open) [T''_{do}] (s)	0.019
Unsaturated reactance [X_q] (pu)	0.117
Unsaturated sub-transient reactance [X''_q] (pu)	0.0081

The turbo-generator train contains a gas turbine coupled through a gear-box (5109 RPM/1500 RPM) to the synchronous generator. The lumped component model of the turbo-generator train is shown in Fig. 3(a) with 18 lumped masses. Based on generator datasheet, these 18 masses have two torsional frequencies under 50 Hz, i.e. 11.5 Hz and 33.9 Hz. As just the 11.5 Hz mode is excited in the LNG plant according to the mechanical measurements. Hence, in this study, the mechanical train has been modelled as 2-mass – one spring system which has the same frequency and mode shape as the one given for the 18-mass model at 11.5 Hz torsional mode. The corresponding mode shape given in datasheet is shown in Fig. 3(b) and the equivalent 2-mass model is shown in Fig. 3(c) implying the same behavior in the 11.5 Hz torsional frequency. Furthermore, the equivalent moment of inertia for each masses and spring stiffness constant is given in Table 3.

According to [6], [7], power converters can inject sub-harmonics to the grid depend on the frequency of the ac grid and motor side. The injected frequencies, f_{ac} , to the ac side can be found as $f_{ac} = (6k_2 \pm 1)f_m \pm 6k_1f_s$, where f_s and f_m are the ac grid and motor frequency, $k_1 = 0,1,2,\dots$ and $k_2 = 0,1,2,\dots$ [14]. Thereby, the injected frequencies may stay under synchronous frequency, i.e., f_s , which can excite the torsional modes of turbo-generator train if the amplitude of the injected component and hence the resultant torque on the rotor shaft is high enough. In the studied LNG plant, in practice, the generator can properly operate with one compressor, while small vibrations appear on the shaft. However, starting the second compressor causes higher mechanical vibrations activating the mechanical relay on the journal bearing. Since the system has enough damping for operation of one compressor, however, insufficient damping for two compressors, the system will be tripped in the case of operating two compressors.

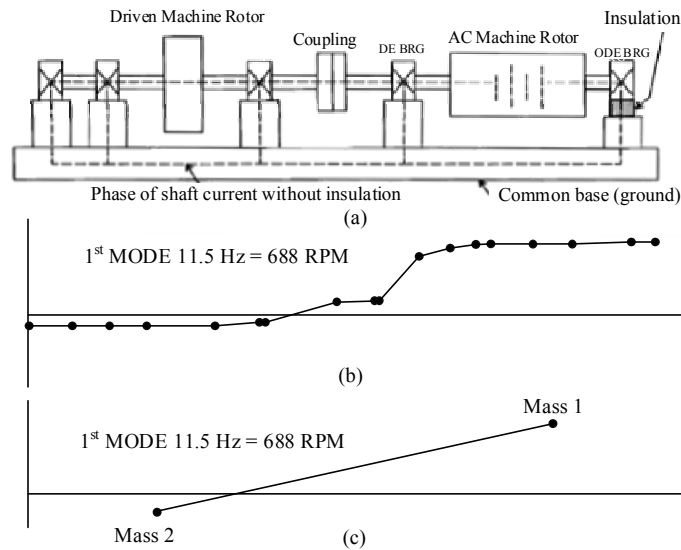

Fig. 3: Torsional model of the turbo-generator train: (a) lumped model, (b) 1st torsional mode shape (11.5 Hz) implying participation of different parts of turbo-generator, and (c) equivalent mode shape of 1st torsional mode.

Table 3: Equivalent two-mass system model (mass-spring model) for turbo-generator train.

Equivalent parameters	Value (SI)
Moment of Inertia for mass1 [J_1]	14081.19
Moment of Inertia for mass2 [J_2]	2067.47
Spring Constant (Stiffness) [K_{12}]	9202765
Natural frequency	11.5

3. Proposed Adaptive Active Damper

In order to absorb the sub-harmonic currents of compressors, and hence, adding enough damping to the electro-mechanical system, an active damper is proposed as shown in Fig. 4. Since the instability occurs during starting the second compressor, the active filter control system should have a fast enough dynamic response. Hence, an adaptive filter [15] is employed to extract the 38.5 Hz components of the compressors current. Furthermore, as shown in Fig. 4, a hysteresis modulation technique is employed to further increase the system dynamic response.

4. Simulations and Experiments

During the experimental tests and simulation, the plant is operated in the islanded mode. Two *Hioki 3196* power analyzers are installed in the ac terminal of synchronous generator and compressors. Furthermore, one vibration data analyzer *STD-3300* is installed on the turbo-generator gearbox in order to measure the mechanical oscillations. The recorded data during test is reported in Fig. 5 and Fig. 6.

Fig. 5(a) shows the terminal voltage of generator before tripping, where it includes around 11.5 Hz envelope over the fundamental 50 Hz voltage signals. Furthermore, the compressors currents before generator tripping is shown in Fig. 5(b). This current waveforms contain fundamental frequency, 5th, 7th and 11th harmonics of motor drive and 11.5 Hz envelope. Following Amplitude Modulation (AM), if the amplitude of an ac signal, $\sin(\omega_1 t)$ is modulated by another ac signal, $\sin(\omega_2 t)$ with an amplitude of modulation equal to A , the signal will be appeared as $\sin(\omega_1 t)(1 + A \cdot \sin(\omega_2 t))$. The Fourier spectrum of this signal consist of components with the frequency of ω_1 , $\omega_1 + \omega_2$, and $\omega_1 - \omega_2$. Therefore, the harmonic spectrum of generator voltage and compressors current contains the frequency of 50 Hz, $50 - 11.5 = 38.5$ Hz, and $50 + 11.5 = 62.5$ Hz. The FFT spectrum of ac current of compressors during generator tripping is shown in Fig. 6(a) implying the presence of 38.5 Hz component over the fundamental frequency in the ac currents. Moreover, the vibration on the turbo-generator gearbox during trip is shown in Fig. 6(b) indicating that before tripping the amplitude of the sub-harmonic component is very small. However, close to the tripping point, this component amplitude is growing, and finally, the corresponding mechanical protection relay on the journal bearing stops the turbo-generator.

Different tests illustrate that the generator is tripped due to the operation of the mechanical relay on the journal bearing with the frequency of 11.5 Hz. Furthermore, electrical measurements on the ac side indicate the presence of complementary component of torsional frequency of 11.5 Hz (i.e., $50 - 11.5 = 38.5$ Hz) on the ac voltage and current waveforms. Therefore, the mechanical torsional mode of 11.5 Hz is excited by the electrical system.

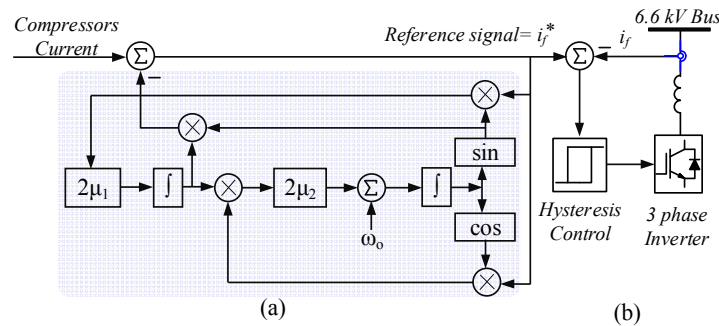

Fig. 4: Control block diagram of the proposed active damper; (a) adaptive filter for extracting sub-harmonic components – $\mu_1=100$, $\mu_2=1$, (b) hysteresis control for 3 phase inverter as the active damper.

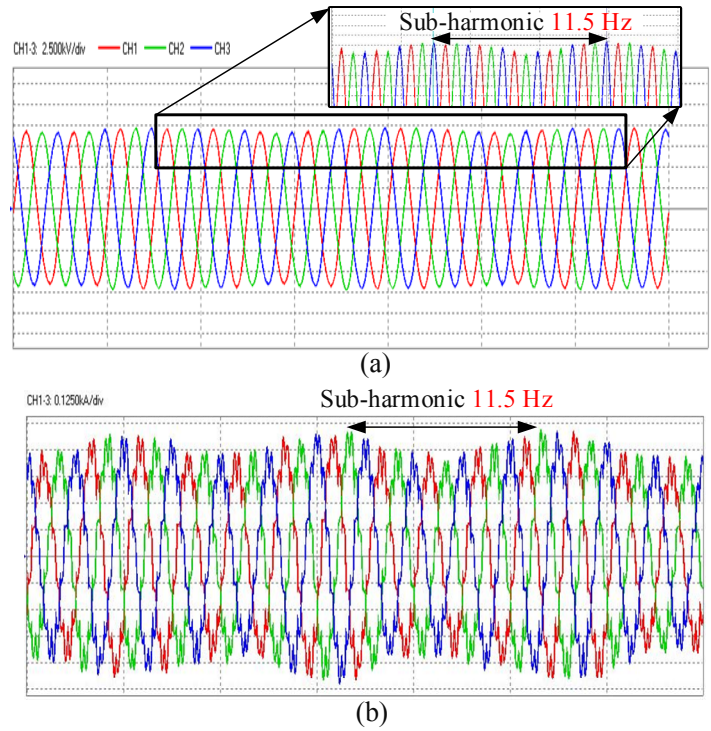

Fig. 5: Measured experimental results: (a) generator voltage, and (b) compressors current before filter banks containing 11.5 Hz envelope – Voltage base [2.5 kV/div], Current base [125 A/div], and Time base [0.04 s/div].

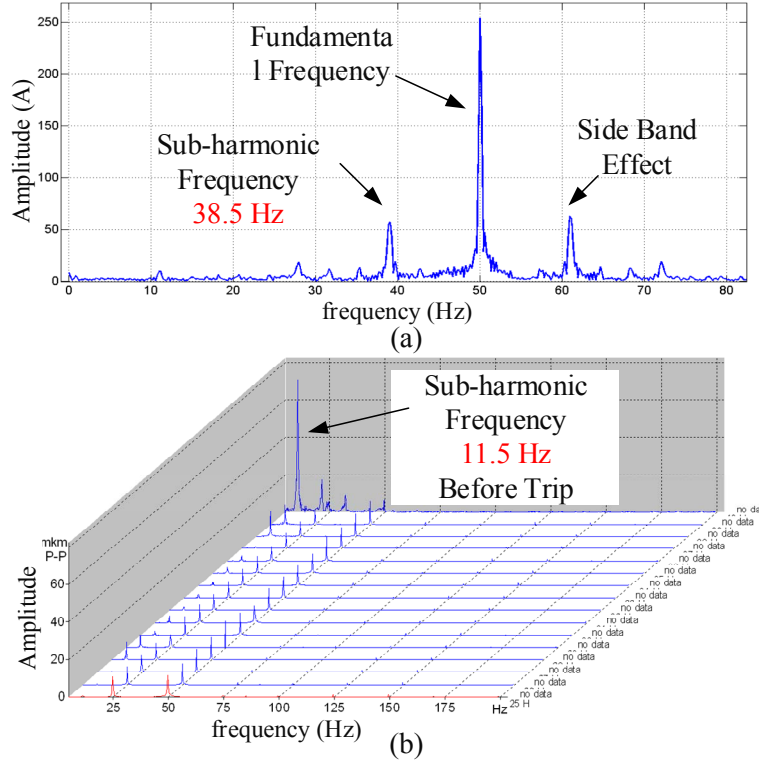

Fig. 6: Measured experimental results: FFT spectrum of (a) compressors current before the trip, and (b) gearbox lateral vibrations.

In order to compensate the subharmonic components of compressor currents, an active filter is designed. The dynamic performance of the active filter is shown in Fig. 7. As it can be seen, the 38.5 Hz component of compressor current is appropriately extracted from the fundamental component. This current is employed as the reference current of active filter to absorb the sub-harmonic component of compressor current and prevents flowing it to the generator side.

The simulation results without and with the proposed active damper are reported in Fig. 8 and Fig. 9. The first compressor is started at $t = 10\text{ s}$, and 5th, 7th and 11th harmonic filter banks are started 5 s after first compressor. As shown in Fig. 8(a) and Fig. 9(a), the rotor torque has converged, and hence, it is stable. However, the second compressor is started at $t = 30\text{ s}$, and another 11th harmonic filter bank 5 s after the second compressor. The rotor torque wave in Fig. 8(a) shows that the system is not stable. Moreover, the harmonic spectrum of compressors current shown in Fig. 8(b) implying the presence of 38.5 Hz component in ac side. This frequency is the complementary component of turbo-generator torsional frequency. However, as shown in Fig. 9(a), employing the proposed active filter can appropriately absorb the sub-harmonic components and provides a stable operation condition. The harmonic spectrum of the compressors current shown in Fig. 9(b) illustrates the elimination of the 38.5 Hz sub-harmonic component. Hence, the natural frequency of turbo-generator train is not excited and system is stable.

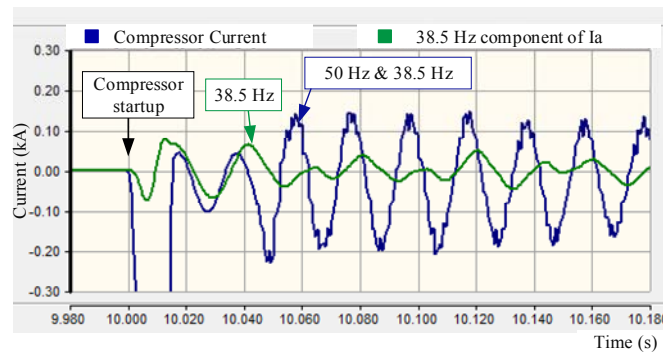

Fig. 7: Obtained simulation results: Performance of proposed active damper control in extracting 38.5 Hz component from compressors current.

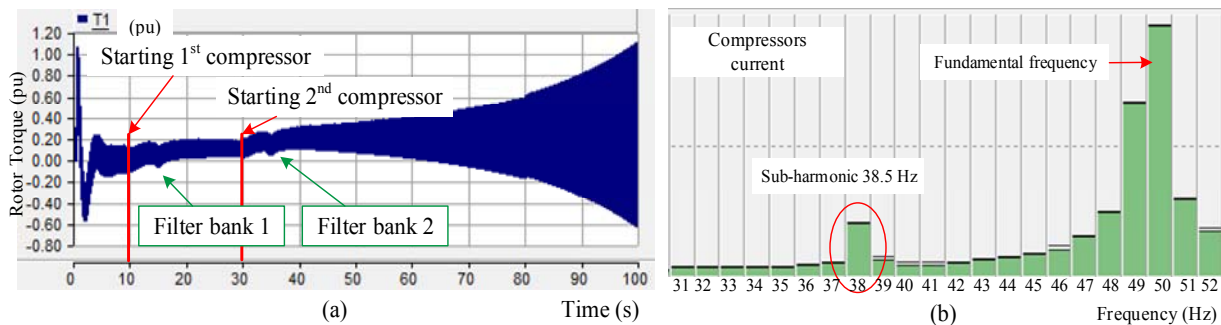

Fig. 8: Mechanical torque (per unit) on rotor shaft without active damper: (a) rotor torque (b) harmonic spectrum of compressors current.

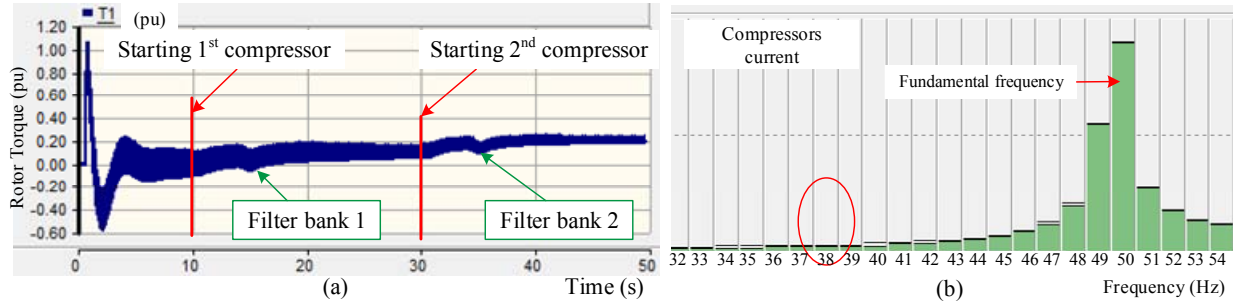

Fig. 9: Mechanical torque (per unit) on rotor shaft with active damper: (a) rotor torque (b) harmonic spectrum of compressors current.

5. Conclusion

In this paper, the sub-harmonic stability issues due to the electro-mechanical interaction between compressor motor drives and turbo-generator train in an LNG plant is investigated. The natural torsional frequency of turbo-generator may be excited by the sub-harmonic currents injected by the compressors due to the lack of enough damping in electro-mechanical system. The proposed active damper appropriately absorbs the sub-harmonic currents of compressors and provides sufficient damping to the electro-mechanical system. Hence, stable operation can be achieved in the islanded mode of operation. Experimental tests validate the electro-mechanical interaction phenomenon in the system and simulation results validate the effectiveness of the proposed approach.

6. References

- [1] X. Wang, F. Blaabjerg, and W. Wu, "Modeling and Analysis of Harmonic Stability in an AC Power-Electronics-Based Power System," *IEEE Trans. Power Electron.*, vol. 29, no. 12, pp. 6421–6432, 2014.
- [2] X. Wang, F. Blaabjerg, M. Liserre, Z. Chen, J. He, and Y. Li, "An Active Damper for Stabilizing Power-Electronics-Based AC Systems," *IEEE Trans. Power Electron.*, vol. 29, no. 7, pp. 3318–3329, Jul. 2014.
- [3] R. Peña-Alzola, M. Liserre, F. Blaabjerg, R. Sebastián, J. Dannehl, and F. W. Fuchs, "Analysis of the Passive Damping Losses in LCL-Filter-Based Grid Converters," *IEEE Trans. Power Electron.*, vol. 28, no. 6, pp. 2642–2646, Jun. 2013.
- [4] W. Wu, Y. He, T. Tang, and F. Blaabjerg, "A New Design Method for the Passive Damped LCL and LLCL Filter-Based Single-Phase Grid-Tied Inverter," *IEEE Trans. Ind. Electron.*, vol. 60, no. 10, pp. 4339–4350, Oct. 2013.
- [5] C. Yoon, H. Bai, R. N. Beres, X. Wang, C. L. Bak, and F. Blaabjerg, "Harmonic Stability Assessment for Multiparalleled, Grid-Connected Inverters," *IEEE Trans. Sustain. Energy*, vol. 7, no. 4, pp. 1388–1397, Oct. 2016.
- [6] L. Hu and R. Yacamini, "Harmonic Transfer through Converters and HVDC Links," *IEEE Trans. Power Electron.*, vol. 7, no. 3, pp. 514–525, Jul. 1992.
- [7] R. Yacamini, "How HVDC Schemes Can Excite Torsional Oscillations in Turbo-Alternator Shafts," *IEE Proc. C - Gener. Transm. Distrib.*, vol. 133, no. 6, pp. 0143–7046, 1986.
- [8] J. C. Wachel and F. R. Szenasi, "Analysis Of Torsional Vibrations In Rotating Machinery," in *Proc. 22nd Turbomachinery Symposium*, 1993, pp. 127–151.
- [9] L. Hu, R. Yacamini, R. Y.-I. T. on power Electronics, and U. 1992, "Harmonic Transfer through Converters and HVDC Links," *IEEE Trans. Power Electron.*, vol. 7, no. 3, pp. 514–525, 1992.
- [10] H. Volker, R. M. Zurowski, and M. Hilscher, "Torsional Interharmonic Interaction Study of 75 Mw Direct-Driven Vsds Motor Compressor Trains for Lng Duty," in *Proc. 37th Turbomachinery Symposium*, 2008, pp. 57–66.
- [11] M. H. Nehrir, M. K. Donnelly, and R. Adapa, "Thyristor-Based Damping of Turbine-Generator Shaft Torsional Oscillations Resulting from Power System Disturbances and Subsynchronous Resonance-a Review," in *Proc. IEEE Power Symposium, the Twenty-Second Annual North American*, 1990, pp. 54–60.
- [12] M. Hernes and B. Gustavsen, "Simulation of Shaft Vibrations due to Interaction between Turbine-Generator Train and Power Electronic Converters at the Visund Oil Platform," in *Proc. IEEE Power Conversion Conference*, 2002, pp. 1381–1386.
- [13] A. Miri and C. Sihler, "Active Damping of Torsional Modes in Turbine-Generator Shafts," in *Proc. IEEE PESC*, 2009.
- [14] R. Yacamini, "Power System Harmonics. Part 4: Interharmonics," *Power Eng. J.*, vol. 10, no. 4, pp. 185–193, Aug. 1996.
- [15] M. Karimi, H. Mokhtari, and M. R. Iravani, "Wavelet Based on-Line Disturbance Detection for Power Quality Applications," *IEEE Trans. Power Deliv.*, vol. 15, no. 4, pp. 1212–1220, 2000.