



**AALBORG UNIVERSITY**  
DENMARK

**Aalborg Universitet**

## **Restoration of Low-Voltage Distribution Systems with Inverter-Interfaced DG Units**

Dietmannsberger, Markus; Wang, Xiongfei; Blaabjerg, Frede; Schulz, Detlef

*Published in:*  
I E E Transactions on Industry Applications

*DOI (link to publication from Publisher):*  
[10.1109/TIA.2017.2770103](https://doi.org/10.1109/TIA.2017.2770103)

*Publication date:*  
2018

*Document Version*  
Accepted author manuscript, peer reviewed version

[Link to publication from Aalborg University](#)

*Citation for published version (APA):*  
Dietmannsberger, M., Wang, X., Blaabjerg, F., & Schulz, D. (2018). Restoration of Low-Voltage Distribution Systems with Inverter-Interfaced DG Units. *I E E Transactions on Industry Applications*, 54(5), 5377-5386. [8094888]. <https://doi.org/10.1109/TIA.2017.2770103>

### **General rights**

Copyright and moral rights for the publications made accessible in the public portal are retained by the authors and/or other copyright owners and it is a condition of accessing publications that users recognise and abide by the legal requirements associated with these rights.

- ? Users may download and print one copy of any publication from the public portal for the purpose of private study or research.
- ? You may not further distribute the material or use it for any profit-making activity or commercial gain
- ? You may freely distribute the URL identifying the publication in the public portal ?

### **Take down policy**

If you believe that this document breaches copyright please contact us at [vbn@aub.aau.dk](mailto:vbn@aub.aau.dk) providing details, and we will remove access to the work immediately and investigate your claim.

# Restoration of Low-Voltage Distribution Systems with Inverter-Interfaced DG Units

Markus Dietmannsberger  
Electrical Power Systems  
Helmut Schmidt University

Xiongfai Wang  
Energy Technology Department  
Aalborg University

Frede Blaabjerg  
Energy Technology Department  
Aalborg University

Detlef Schulz  
Electrical Power Systems  
Helmut Schmidt University

**Abstract**—The increasing share of distributed generation (DG) offers new chances in grid restoration of low-voltage distribution grids. Instead of relying on the transmission or high- and medium-voltage levels, establishing islanding operation in low-voltage grids might be a good option after a wide-area voltage collapse. This paper proposes a restoration strategy from zero voltage conditions for inverter-interfaced DG under islanded conditions. In the approach, a flexible and scalable Master DG inverter concept is introduced for distributed generations, where no communication is needed and an outage of the Master can be balanced by other DG inverters. The control strategy ensures the tracking of nominal values of the system voltage and frequency without zero steady-state error. The influences of non-controllable DG are also taken into account in the strategy with an effective countermeasure developed. Experimental results verify the effectiveness of the proposed approach.

**Index Terms**—distributed generation control; islanding operation; multiple inverters; power system restoration

## I. INTRODUCTION

Restoration of distribution grids has mainly been achieved by top-down restoration strategies which use the approach to re-connect small parts of the grid step-by-step. Traditional top-down approaches are based on the assumption that there is a working transmission grid that can provide stability and to which the distribution grids can be connected to. One of the main goals is to optimize reconfiguration of the network by using the potential of distributed generation (DG) as in [1] and [2]. They use multi-agent systems or hybrid control approaches to find optimal restoration sequences [3].

But during a wide-area blackout, when the transmission grid or parts of the high- and medium-voltage level are not available, there might be better chances to restore grid operation with a bottom-up approach and using existing DG in low-voltage grids. In [4], black start strategies for low-voltage grids have been proposed. The authors suggested a communication based restoration sequence and control approach for voltage and frequency control—one of the key issues in islanding operation. The benefits of using DG for restoration have been quantified in [5]. DGs with black-start ability initiated islanding operation in different cells. But there was no discussion on how to coordinate multiple black-start DGs within a single cell.

Several approaches for the voltage-controlled islanding operation of DG units have recently been discussed. The simplest approach is the operation of a single generation unit as a voltage source [6]–[8].

For operating multiple DGs, there are mainly two approaches. The first approach is active load sharing, where information is shared among inverters via communication. One mechanism is the average current/power sharing scheme as proposed in [9] and [10]. All inverters participate in both voltage and current control. Therefore a communication link for the reference values is used. This approach achieves good results for power sharing and voltage quality. But if communication fails among the generation units, the system is not able to operate. Furthermore, it is challenging to include external generation units that have not been adapted to the active power sharing scheme.

Another possible mechanism is the Master-Slave sharing [11]–[13]. The Master operates as a voltage source (grid forming unit) and multiple Slaves act as current sources (grid feeding units). The share of each generation depends on the output impedance. Again, information for load sharing is shared via communication link. Master-Slave sharing methods have some drawbacks in common. The grid forming unit must be able to initially re-establish grid voltage at nominal values without the support of other DGs. Furthermore the whole system is not stable any more if the grid forming unit has an outage [14]. Like all current/power sharing mechanism, this concept can only be used with communication. Thus, for islanding operation in distribution grids active load sharing approaches might not be an option. There is a relatively high number of DG that could hardly be incorporated.

The second approach is to operate with multiple voltage sources. In this case, an adequate and proper power sharing among the voltage sources must be implemented. Most commonly, the droop control is used to share active and reactive power between the voltage sources [15], [16]. The droop control method incorporates the control of output active and reactive power dependent on frequency and amplitude with a proportional controller. Most often, the relation between active power and frequency ( $P-\omega$ ) and reactive power and voltage ( $Q-V$ ) is used [15]. In [16], a reverse droop control ( $Q-\omega$  and  $P-V$ ) was presented using a resistive impedance in order to improve the power sharing for resistive grids. The droop control achieves good results and is relatively robust to a loss of communication. But fluctuations in loads and generations lead to small deviations from the set-point also dependent on line impedances [17]. Thus, a secondary control (centralized or decentralized) is required to provide new set-

points and eliminate steady-state errors. Active and reactive power need to be measured with a low-pass filter which increases response time during step changes. Furthermore, a secondary control (centralized or decentralized) is required to eliminate steady-state errors. All in all, the control concept of droop control relies on a reliable communication infrastructure [14], [18]–[20]. Thus, applying this concept in low-voltage grids might not be very economic because of the large number of generators and the associated high costs for communication lines.

Communication-based approaches are very strong and can provide large benefits in robust control hierarchies and implementations. But still, communication-based control might not be possible in low-voltage grids because of the large number of generators and the associated high costs for communication lines. Thus, this paper provides an alternative approach for the control of islanded grids without communication and yet without steady state errors.

This paper proposes a restoration strategy and control approach that combines the advantages of both the Master-Slave concept and the droop control. We present a scalable and flexible restoration strategy for inverter-interfaced DGs which is able to establish the islanding operation at the nominal voltage and frequency of low-voltage grids consisting of linear  $RLC$  loads and nonlinear constant power loads (CPL). Motor loads are not investigated. This is done from zero voltage condition and without the help of communication. Moreover, in the approach, every inverter unit can be either grid-forming or grid-feeding, which makes the control strategy applicable for both single and multiple DGs. Furthermore the method is transferable to different grid compositions. In case of an outage of the Master unit, the system can still operate without steady state errors, although the control is not based on communication. Furthermore, the concept uses the whole potential of every single inverter during the start-up process from zero voltage. This allows to use the collective active power and thus increases the chances for successful and robust islanding operation. In addition, the control approach is able to deal with an excess of active power which comes from the non-controllable DG units. This paper focuses on the control approach. Protection schemes (for example single or three-phase faults) are not investigated. Load sharing is also not considered. Experimental tests under different load and generation conditions validate the robustness and versatility of the proposed control strategy.

## II. RESTORATION STRATEGY

Fig. 1 shows an example for a single line equivalent circuit of a representative test scenario and the possible participants in low-voltage islanded grids. There may be different types of loads: linear  $RLC$  loads and nonlinear constant power loads (CPL).

In previous work, single-inverter islanding conditions for different types of loads have been investigated in simulation and experimental results [21]. The variation of several loads showed that challenging conditions for voltage and frequency

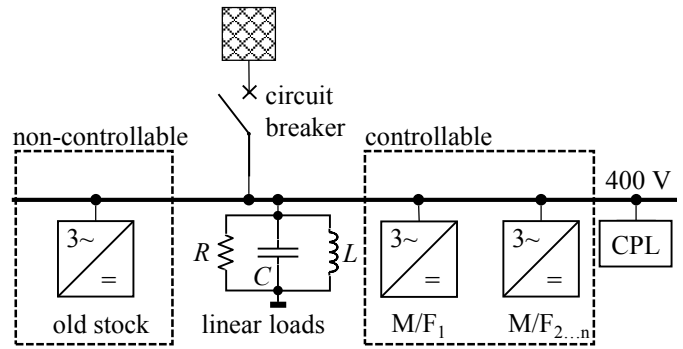

Fig. 1. Low-voltage islanded grid with a connection to the medium voltage grid that can be disconnected by a circuit breaker. Several linear loads ( $RLC$ ) and nonlinear loads (constant power load, CPL) are assumed. Controllable (Master M / Follower F) and non-controllable (*old stock*) inverters are connected to the islanded grid.

control are loads that are too large for a single inverter or open circuit conditions (subsection IV-A), nonlinear constant power loads (subsection IV-B) and reactive-only loads (subsection IV-C). Thus, for the following investigation in multi-inverter operation, these scenarios are selected to describe the functionality of the proposed approach. Therefore, in each test an adequate linear or nonlinear load of Fig. 1 is set. This modelling is only valid in the range of the reference frequency 50 Hz and does not cover effects of harmonics in the system, which are not investigated here.

The inverters which are equipped with the proposed control strategy are referred to as Master M or Follower F. Followers have the full potential of a Master. In addition to the Master and Follower units, there can be ordinary DG inverters, which are non-controllable and thus represent a disturbance unit (*old stock*). The system is a balanced three-phase system. In case of a blackout in the medium-voltage grid, voltage will collapse. This makes the DGs stop feeding the grid within a few milliseconds [22]–[24]. Hence, the initial condition is zero voltage. The circuit breaker of Fig. 1 can now island the low-voltage grid from the rest of the grid.

### A. Power Balance in Islanded Grids

In order to operate the island of Fig. 1 within the permitted voltage and frequency range, the generators have to feed at least the amount of active and reactive power that is consumed by the loads (an effective countermeasure against an excess of non-controllable power is shown in section II-C). The linear loads can be described with linear electrical components with resistive part  $R$  and reactive parts  $L$  and  $C$ . The constant power load is a controlled rectifier which consumes a constant active and reactive power  $P_{CPL}$ ,  $Q_{CPL}$ , the generation ( $P_G$  and  $Q_G$ ) and consumption ( $P_L$  and  $Q_L$ ) should be balanced as in

$$P_G = P_L = \frac{V_i^2}{R} + P_{CPL} \quad (1)$$

$$Q_G = Q_L = V_i^2 \cdot \left( \frac{1}{2\pi f \cdot L} - 2\pi f \cdot C \right) + Q_{CPL} \quad (2)$$

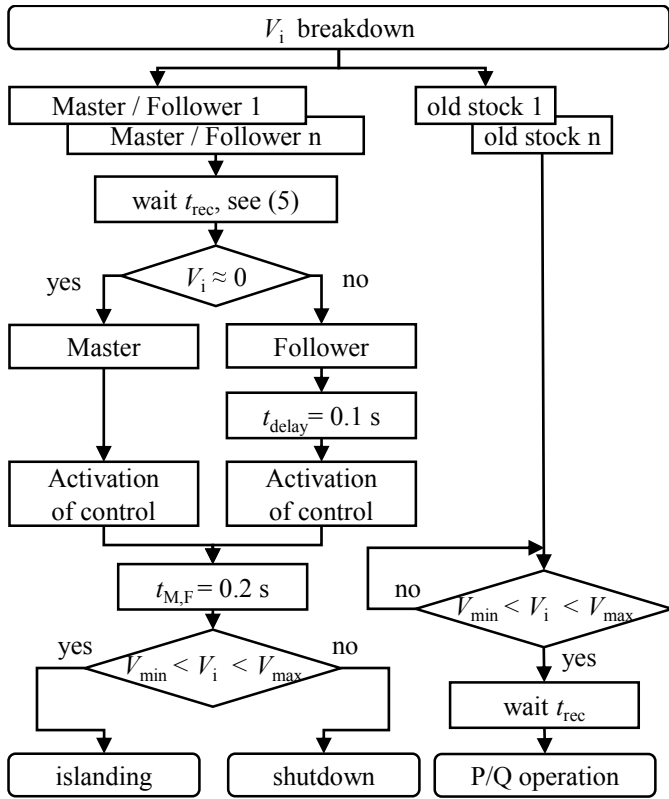

Fig. 2. Flow chart for re-establishing voltage in islanded grids. Left: controllable inverters, right: non-controllable inverters.

where  $V_i$  is the root-mean-square value of the applied grid voltage and  $f$  is the grid frequency. As long as the CPL is not yet controlled (early startup phase), the behaviour of the non-controlled rectifier is nearly constant impedance. Equations (1) and (2) show that in islanding conditions, there is a connection between active power and voltage and a connection between reactive power and frequency. This is the opposite of what is usually assumed. If there were motor loads (which are not discussed here), this connection would also be different.

According to German grid codes [22], the voltage and frequency have to be within

$$V_{\min} = 80 \% V_n \leq V_i \leq 110 \% V_n = V_{\max} \quad (3)$$

$$f_{\min} = 47.5 \text{ Hz} \leq f \leq 51.5 \text{ Hz} = f_{\max} \quad (4)$$

This is the range of the active and reactive power that the generators must supply. Grid codes in other countries vary but are similar to this standard.

From (1)-(4), the following can be concluded: the operation of an island is possible and valid if and only if the provided active and reactive power results in an accurate voltage and frequency. If voltage and frequency can not be re-established within the limits, the operation must be terminated.

### B. Start-Up Procedure and Operation Modes of Generation Units

Fig. 2 illustrates the restoration process. Inverter units that are equipped with the proposed control strategy are called

Master or Follower MF. Unlike Slaves in conventional Master-Slave approaches, the Followers have the full potential of Masters (see below) and are able to control the island without any further control unit. Because of this, they are not called Slaves because this name often indicates that Slaves can not operate without a Master—which is not the case here. All inverter units that cannot be controlled (for example older photovoltaic plants) will be called *old stock inverters*. They are not part of the control strategy but act as a disturbance when re-connecting to the island.

After a severe grid fault or a wide-area blackout, the voltage will collapse and the circuit breaker of Fig. 1 can be opened. When the voltage collapses, all *old stock inverters* will immediately trip and they will not reconnect either until the grid conditions meet the requirements specified in (3) and (4) for at least a certain amount of time (often several seconds [22]).

The voltage collapse is used as the initial synchronization for all inverters. This means that the voltage must collapse at nearly the same time in the whole islanded grid. In low voltage grids with a limited dispersion, this assumption is valid.

In the left path of Fig. 2, all Masters/Followers are shown. They are able to restore the grid voltage in islanding mode. First, it has to be determined, which of the controllable inverters  $MF_1 \dots MF_n$  becomes the Master inverter because the actual composition of generation units is unknown. As it will have the main responsibility for frequency stability and thus should be able to provide a large amount of reactive power, it is the best to nominate the one with the highest nominal power. As shown in Fig. 2, after the voltage has collapsed, all possible Masters/Followers MF are waiting for a certain recovery time  $t_{\text{rec}}$  that depends on the inverse of the respective nominal power  $P_n$ :

$$t_{\text{rec}} = \frac{c}{P_n} + t_{\text{rand}} \quad (5)$$

where  $c$  is as a constant that defines how large  $t_{\text{rec}}$  actually is. For example: with  $c = 20 \text{ s} \cdot \text{kW}$ , a 10 kW inverter would try to restore the grid after 2 s, a 5 kW inverter after 4 s, and so on. In order to prevent two inverters with the same nominal power starting at the same time, a small random time constant  $t_{\text{rand}}$  is added to  $t_{\text{rec}}$ . During  $t_{\text{rec}}$ , the inverter monitors grid voltage. If it remains close to zero, the inverter can conclude that it is the largest MF in the island and sets itself as the Master. It will then start to energize the grid and restore the voltage to nominal value. All other possible MF inverters detect that voltage is being restored and thus define themselves as Followers. The voltage control loop that is used has a time constant of  $\tau_V = 4 \dots 20 \text{ ms}$ . Because of this, an increase in voltage will be detected very fast and the chance of simultaneous Master activation of two or more inverters is very low.

Now the Master tries to restore the nominal voltage. If it has enough active power, the nominal value will be reached. Otherwise, a lower value according to (1) will be established. If there is some transient behaviour or load switching during

this first period that demands more power than the Master can provide, the voltage level will decrease. The support by the Followers starts after a short time delay  $t_{\text{delay}}$  in order to give the Master enough time to (partly) restore the voltage in the first place. Irrespective of the actual voltage level after  $t_{\text{delay}}$ , the Followers join and provide their active power. This will either further increase the voltage level until its nominal value is reached (if the Master was not able to provide enough power) or the nominal voltage level will simply be maintained (but now controlled by the Master and Followers). Because of the fast voltage control loops,  $t_{\text{delay}}$  is set to 100 ms. If the total provision of the active power of Master and Followers is not enough to bring voltage above the minimum limit of  $V_{\text{min}} = 80\% V_n$  within  $t_{\text{M,F}} = 200$  ms, this is a clear indicator that the available active or reactive power is not sufficient to operate in islanding conditions and they shut down operation. This is the case if reactive power gets priority over active power. The reason for that can be seen in (2). It shows that it is imperative to provide enough reactive power in order to operate at a stable frequency. But the reactive power demand for a constant frequency increases quadratic with an increasing voltage  $V_i$ . However, the voltage level only depends on the active power provision. Thus it can be concluded, that steady state voltage can remain inside the valid range if and only if frequency is controlled to 50 Hz. If voltage is above  $V_{\text{max}}$ , inverters will shutdown as well.

With the proposed schedule, all the controllable active power is used to have the highest possibility to be able to restore the grid. In contrast to the Master-Slave concept in [11]–[13], the active power reserves of all inverters can be used (either from the beginning or after  $t_{\text{delay}}$ ). Furthermore, the Master can not be overloaded because it does not have to provide more power than it is able to. For the coordination of possible Master and Followers, no additional communication infrastructure is needed as they indirectly communicate via the grid voltage level to determine their role in the islanded grid. Thus the proposed approach can be used in every possible composition of the island, irrespective of the amount or size of the inverters. The fact that all MF's are ranked by their nominal power ensures that the Master is the one which can provide the highest amount of reactive power. This is important for stabilizing the frequency in a broader range of reactive power demands. In addition, it is predictable which inverter becomes Master and which ones become Followers because this is irrespective of the actual active power supply of each DG.

### C. Countermeasures against Excess of Active Power

A challenge for the operation of islands is the excess of active power that cannot be controlled because it is provided by *old stock inverters*. If there is too much active power, the voltage will exceed the upper voltage limit and generators will disconnect, which could cause the island to collapse. The control strategy proposed in this paper is capable of dealing with this problem by changing the island frequency.

According to German grid codes, all generators must reduce their active power by 40%/Hz as soon as the frequency exceeds 50.2 Hz up to a frequency of 51.5 Hz. As long as the frequency does not drop below 50 Hz eventually, active power must not be increased any more. This behaviour is mandatory for grid operation and prescribed in German grid codes [22]. Before the changes in grid codes [22], inverters simply shut down in case the frequency exceeded 50.2 Hz. But with increasing installation numbers, this had the potential to severely harm the overall grid stability in Germany and other European countries. Because of this, many inverters have been retrofitted with the active power reduction. Thus, in the following it is assumed that DG units actually behave in accordance with [22].

The proposed control strategy is shown in the flow chart of Fig. 3. In case there is an excess of active power in the island, the voltage will increase. As soon as it exceeds a certain limit  $V_{\text{lim}}$ , the Master changes island frequency above 50.2 Hz. Thus the *old stock inverters* reduce their active power (a) and/or stop the increase of active power (b). Thus the increase in voltage is stopped.

In fact, there are two possible scenarios that could lead to rising voltages: either the load is decreasing or the non-controllable generation is increasing. First, a decreasing load demand is considered.

#### 1) Decrease of Load Demand:

In order to supply a certain amount of linear loads (resistance  $R$ ) with active power  $P_L$ , the amount of active power provided by *old stock inverters*  $P$  needs to be maintained within  $P_{\text{min}}$  and  $P_{\text{max}}$  to operate at a valid voltage level  $V_i$  in islanding mode. From (3) it can be derived:

$$P_{\text{min}} = \frac{0.80^2 \cdot V_n^2}{R} \leq \frac{V_i^2}{R} = P_L \leq \frac{1.10^2 \cdot V_n^2}{R} = P_{\text{max}} \quad (6)$$

Thus, the island can only remain stable as long as the *old stock DG* active power  $P$  is less or equal to  $1.21 P_L$ .

The proposed control strategy changes the operating frequency  $f$ . A droop is applied that defines the new operating frequency  $f_{\text{new}}$  dependent on the actual voltage level. The change in frequency  $\Delta f$  shall be zero below a lower limit  $V_{\text{lim}}$  and maximum if the voltage  $V_i$  reaches the upper limit  $V_{\text{max}}$ . With this we can calculate  $\Delta f$  to:

$$\Delta f = (51.5 - 50.2) \text{ Hz} \cdot \frac{V_i - V_{\text{lim}}}{V_{\text{max}} - V_{\text{lim}}} \quad (7)$$

51.5 Hz is the maximum frequency that can be used in the island because above this value, operation is prohibited and generators must disconnect [22]. Equation (7) allows to calculate a new frequency reference value  $f_{\text{new}}^*$  as a function of islanding voltage  $V_i$  at the terminals of the Master inverter:

$$f_{\text{new}}^* = \begin{cases} 50 \text{ Hz} & \text{for } V_i < V_{\text{lim}} \\ 50.2 \text{ Hz} + \Delta f & \text{for } V_{\text{lim}} \leq V_i \leq V_{\text{max}} \\ 51.5 \text{ Hz} & \text{for } V_i > V_{\text{max}} \end{cases} \quad (8)$$

The respective curve is shown in Fig. 4.

With the proposed control strategy the possible power range of the *old stock inverters* can be extended to:

$$P_{S,\max,\text{ext}} = \frac{1.10^2 \cdot P_L}{1 - \frac{0.4}{\text{Hz}} \cdot (51.5 \text{ Hz} - 50.2 \text{ Hz})} = 2.52 \cdot P_L \quad (9)$$

This means, that with the proposed countermeasure, the load can decrease to  $1/2.52 = 40\%$  of the *old stock inverters'* active power  $P$ . Otherwise this would be limited to  $1/1.21 = 83\% P$ .

### 2) Increase of Non-controllable Generation:

An excess of active power can also occur if the *old stock inverters* increase their active power. But as soon as the frequency is above 50.2 Hz, the active power must not be increased further. This means that as soon as the *old stock inverters* reconnect to the grid and raise the grid voltage above  $V_{\text{lim}}$ , the Master inverter will set the frequency to  $f > 50.2$  Hz, which results in an immediate stop of active power rise by the *old stock inverters*.

Theoretically, the *old stock inverters'* actual active power could be way higher as long as the increase is small enough and thus the Master has enough time  $\Delta t$  to shift frequency above 50.2 Hz. For example,  $\Delta t = 10$  s would enable the Master to control *old stock inverters* that have  $\approx 70$  times the active power of the load. Some inverter manufacturers have implemented so called Soft Start parameters in order to not disturb the grid too much when reconnecting to the grid. Of course, dependent on the actual grid codes and the parameters given by the manufacturers, those values may vary. As an example, SMA (one of the biggest manufacturers of inverters for low and medium-voltage DGs) provides a set of parameters in [25].

## III. IMPLEMENTATION OF THE PROPOSED CONTROL SCHEME

### A. Implementation of Voltage and Frequency Control

The structure of the voltage and frequency controller for Master and Followers is shown in Fig. 5. Both control loops consist of proportional and integral terms and they are set up to operate in the synchronous reference frame. The  $d$ -component represents active current, the  $q$ -component represents reactive current. Voltage and frequency control loops provide current reference values  $i_{dq}^*$  for the inner control loop. The control concept is based on the fact that voltage can be controlled by active power and frequency can be controlled by reactive power, as shown in (1) and (2). The PLL in the inverters drives the  $q$  component of the voltage to zero. This is achieved with the virtual feed-forward admittance  $X_{ff}^{-1}$  as shown in Fig. 5 (b). The virtual admittance ensures that the phasing of the PLL matches the phase of the islanding voltage. Thus it states:  $V_i = \sqrt{V_d^2 + V_q^2} = V_d$ . With this approach, actual load behaviour matches the aims of the control concept: The voltage in islanded grids depends on the active power and the frequency depends on the reactive power. This assumption is valid because low-voltage grids have a low  $X/R$  ratio and

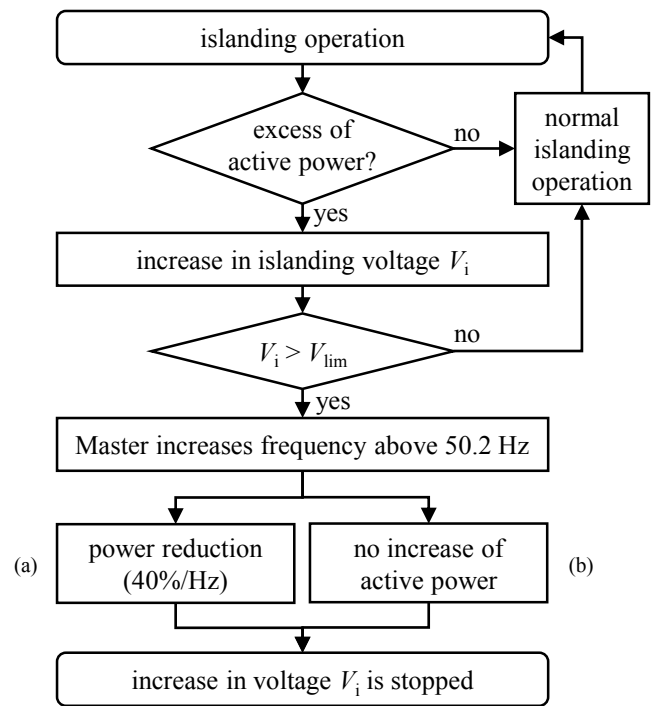

Fig. 3. Flow chart for the activation of frequency dependent active power reduction in *old stock inverter* generation units. Active power is reduced (a) and/or a further increase of active power is stopped (b).

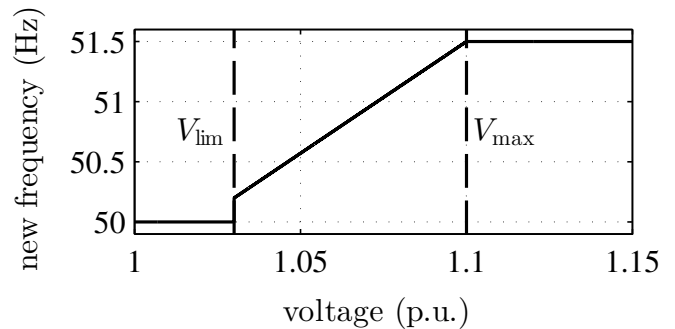

Fig. 4. New frequency reference value  $f_{\text{new}}^*$  as a function of islanding voltage  $V_i$ .  $V_{\text{lim}} = 1.03 V_n$ ,  $V_{\text{max}} = 1.10 V_n$

because the large signal behaviour is dominated by the load characteristics and not by the interconnecting lines.

When the droop concept is used, the controllers of each DG only contain a proportional term which influences either active and reactive power output or voltage and frequency output of the DG [15]. The absence of the integral term results in a high robustness of the droop control but also requires that the initial set-point of active and reactive power must be specified from a central secondary controller via a communication link. Otherwise steady state errors occur.

### B. Differences in Role of Master and Follower

Master and Follower control must have equal capabilities because the determination whether an inverter becomes Master

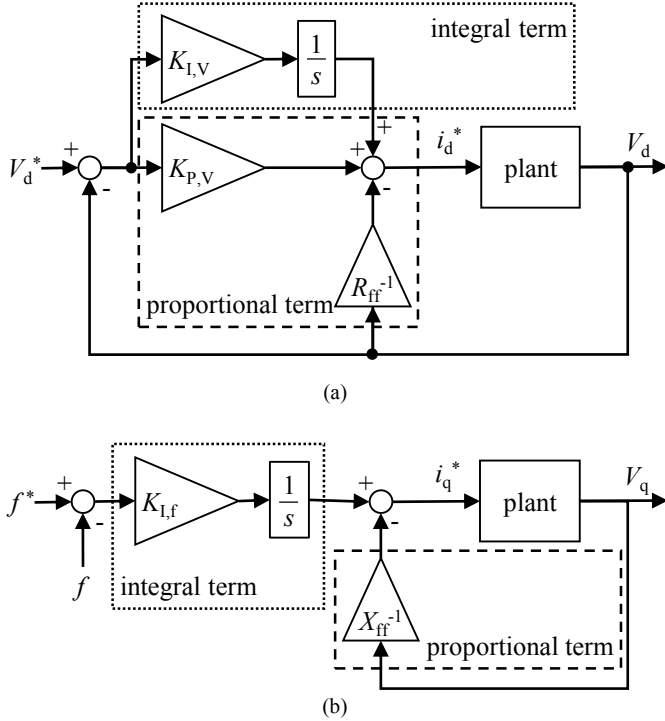

Fig. 5. Control of inverters: (a) Voltage and (b) Frequency control loop of controllable inverters (Master and Follower). Voltage is controlled with active power (current  $i_d$ ) according to (1). Frequency is controlled with reactive power (current  $i_q$ ) according to (2). Both controllers consist of proportional (dashed line,  $K_{P,V}$ ,  $R_{ff}^{-1}$ ,  $X_{ff}^{-1}$ ) and integral controller terms (dotted line,  $K_{I,V}$ ,  $K_{I,f}$ ). The plant consists of the inner current controller and the load. A PLL controls  $V_q$  to zero.

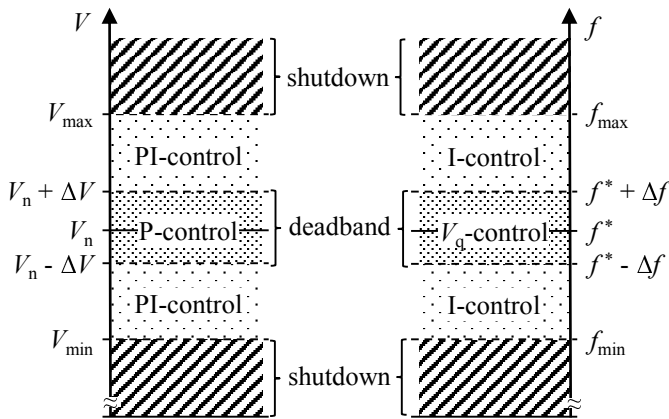

Fig. 6. Concept of deadband control of voltage and frequency that is implemented in Followers. In contrast to the Master, the Followers only activate their integral control part, when the control error exceeds certain limits  $\pm\Delta$ . Within the deadband, only proportional control is active.

or Follower happens at the very start of islanding operation. The separation between Master and Follower control is the fact that in Followers, the integral part of Fig. 5 is only active under certain conditions. This is important to avoid circulating currents.

The Master control is fully operating with proportional and integral terms the whole time as shown in Fig. 5. In contrast, Fig. 6 shows the approach, that is used for the Followers. For both voltage and frequency control a deadband is used. With respect to the voltage control loop, if

$$V_n - \Delta V < V_i < V_n + \Delta V \quad (10)$$

holds true, the Followers only operate with their proportional term  $K_{P,V}$  and  $R_{ff}^{-1}$ . The input of the integral part is set to zero. This ensures, that the actual active current is only changed in small terms according to the deviation to the nominal voltage. If the voltage exceeds  $V_n \pm \Delta V$ , the integral part of the Followers are activated. The error is now reduced until the nominal value is reached again and then the input of the integral part is again set to zero and the Follower provides a new and suitable level of active current.

The violation of  $V_n \pm \Delta V$  appears if the Master has reached its limits of active power. If  $V_i$  drops below  $V_n - \Delta V$ , the Master can not provide more active power and needs to be supported by the Followers. If  $V_i$  exceeds  $V_n + \Delta V$ , the Master has already reduced its active power to  $P_M = 0$ , but if there is still an excess of active power in the islanded grid, the Followers have to reduce their active power, too.

The frequency control works according to the same concept. As long as actual frequency  $f$  stays within the deadband

$$f_n - \Delta f < f < f_n + \Delta f \quad (11)$$

the input of the integral part of the controller is set to zero and reactive current is only controlled by its proportional part  $X_{ff}^{-1}$ . As soon as frequency is exceeding the deadband, the integral controller is activated and drives the frequency back to the nominal value. It remains activated for a specific time  $t_{f,stable}$  and is finally deactivated again.

In fact, the Follower control behaviour within the deadband behaves like a conventional droop control. The proposed concept uses the advantages of droop-control without the need for a communication based secondary controller.

Another advantage of this method is that if there are large loads in the island, the Follower which is closest to the load, will face the smallest voltage level due to the voltage drop in the line resistances. This will cause an increase of the active power provided by this Follower. The fact that voltage is a local variable supports an appropriate allocation of active power between all MF inverters as soon as deviations become too large. A reasonable sharing of the active power is implemented intrinsically by the physics of low-voltage grids.

#### IV. EXPERIMENTAL RESULTS

All the experiments have been done with a dSpace System DS 1007, see Fig. 7. Inverters have been equipped with an LCL-filter ( $L_i = 5$  mH,  $C_F = 5$   $\mu$ F,  $L_g = 1.5$  mH)

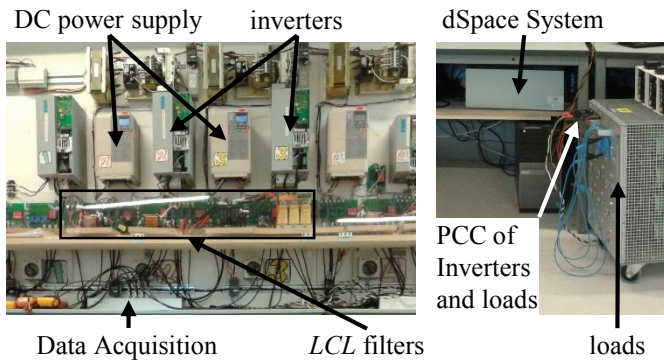

Fig. 7. Experimental setup containing constant DC power supply, inverters, filter components, loads, the point of common coupling (PCC) and a dSpace control system including data acquisition.

TABLE I  
PARAMETERS FOR EXPERIMENT OF GRID RESTORATION.

Symbol	Description	Value
$P_M$	Active power of the Master	4 kW
$P_F$	Active power of the Follower	2.5 kW
$P_L$	Active power of the load	5.8   2   0   4 kW

to attenuate high order harmonics. The filter design is in accordance with standard *LCL*-filter design approaches as explained for example in [26]. At the DC-sides of the inverters, constant voltage sources have been used. The PWM frequency was 10 kHz and the sampling frequency 5 kHz.

#### A. Start-Up Sequence and Adaption to Load Changes

Fig. 8 validates the effectiveness of the coordinated grid restoration process shown in Fig. 2. The values for the setup can be found in Table I. At  $t = 0$  s, the first inverter determines itself as the Master and starts energizing the island. Due to the fact that it can only provide 4 kW, but the load demands for 5.8 kW, it is not able to provide nominal voltage level. The voltage saturates at  $V \approx \sqrt{\frac{4000}{5800}} \cdot V_n = 83\% V_n$ . After a delay time  $t_{\text{delay}} = 0.1$  s, the second inverter (which defined itself a Follower after measuring an increase in voltage due to a Master), joins the rebuilding process and supports the Master by providing the lacking amount of active power. At  $t = 0.17$  s, the nominal voltage level is reached and the Follower disables its integral control part as shown in Fig. 8 (a). At  $t = 0.35$  s, the load is reduced to 2 kW and then to 0 kW at  $t = 0.41$  s (open circuit condition). In both cases, the Master and Follower react to the short voltage overshoot and immediately reduce their active power. Both transients are shorter than the fundamental period (20 ms) which means, that voltage quality is still sufficient. Fig. 8 (c) shows the transient response during a load step. At  $t = 0.64$  s, the load is reconnected. After a short voltage sag to  $0.6 V_n$  for about 20 ms, the voltage can be restored conjointly by the two inverters. One should notice that after the open circuit

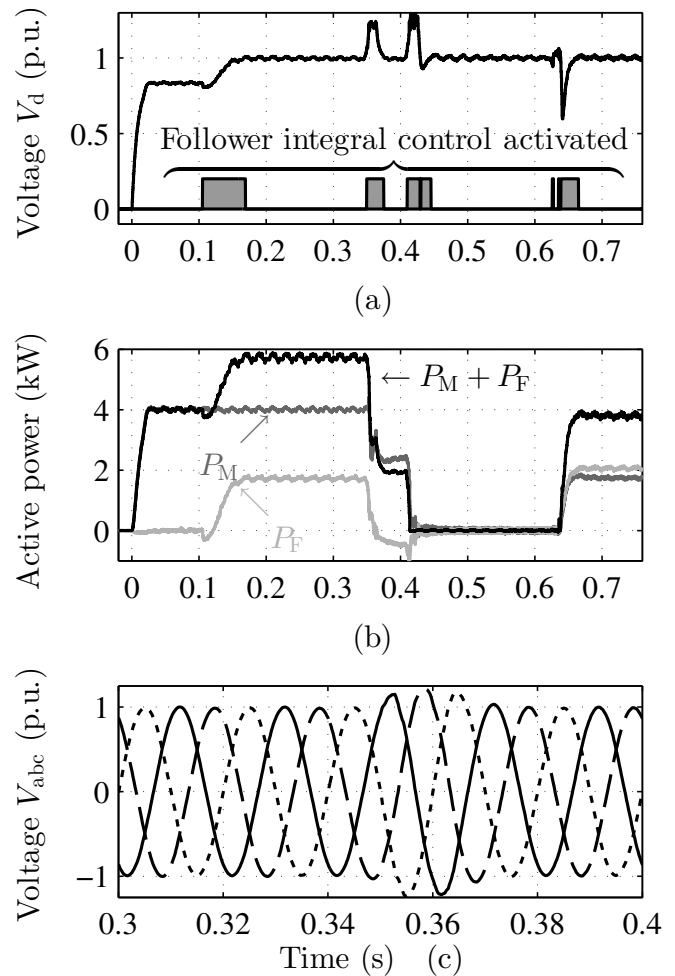

Fig. 8. Grid restoration using a Master and a Follower: (a) Voltage curve and times when the Follower activates its integral part of the controller, (b) Active power provided by Master  $P_M$  and Follower  $P_F$ , (c) transient voltage during load step. Reactive power  $Q$  is zero throughout the whole test.

condition, the active power sharing between the Master and the Follower is different from the first place as shown in Fig. 8 (b). It is not of importance, which of the inverters provides which amount of active power, as long as the sum is equal to the load demand and only one of them (the Master) has its integral part activated. Load sharing is not investigated here. As it can be seen, at  $t = 0.66$  s, the Follower again deactivates its integral part as soon as nominal voltage is reached.

#### B. Supply of nonlinear Constant Power Load

In order to test the robustness of the proposed control strategies, not only linear load conditions but also nonlinear load conditions have been investigated. Therefore, a constant power load (CPL) has been designed using a controlled rectifier with a resistive load on the DC-side.

Fig. 9 (a) and (b) show voltage and frequency respectively. Both during the start-up process ( $t < 5$  s) and during constant power operation, the nominal values can be maintained and disturbances are rejected very fast, even when there is a change



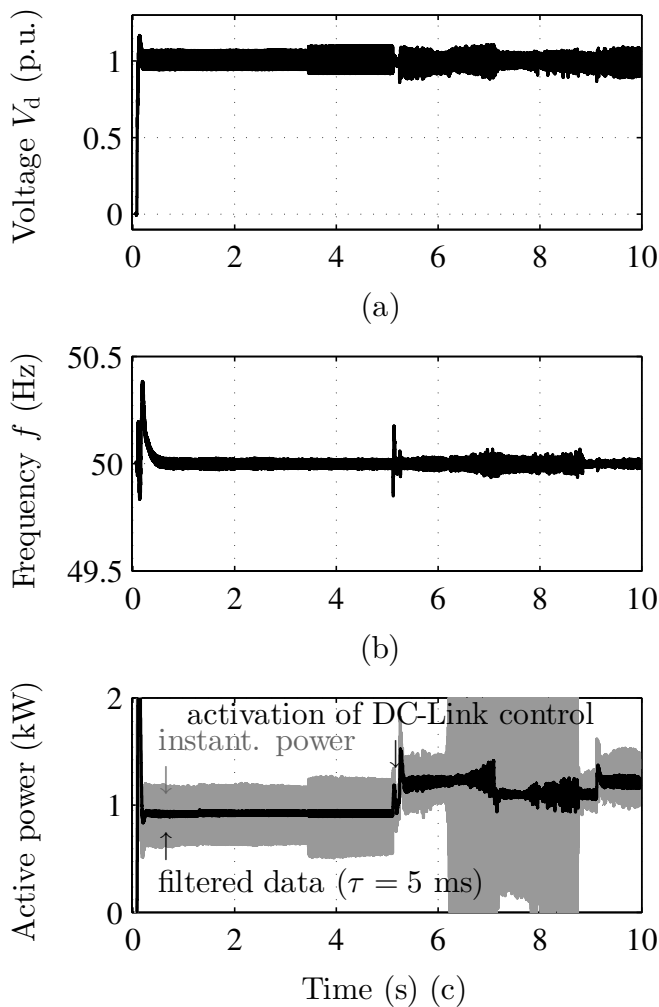

Fig. 9. Supply of a Constant Power Load: (a): voltage; (b): frequency; (c): active power consumption of the load, instantaneous active power  $P_{inst}$  (light-grey), low-pass-filtered active power  $P_{filt}$  (black) and low-pass-filtered reactive power  $Q_{filt}$  (dark-grey).  $\tau_{filt} = 5$  ms.

in power demand. Fig. 9 (c) shows the active power demand of the load. Due to the nonlinear behaviour of the load, the instantaneous power (grey curve) was filtered with a low-pass-filter (black curve) to show the step in power consumption.

### C. Compensation of Master Outage

Fig. 10 shows the results of an experiment in which the Master inverter trips at  $t_0 = 0.5$  s. The values for the experiment can be found in Table II. The event leads to deviations in both voltage Fig. 10 (a) and frequency Fig. 10 (b). According to the procedure described in Fig. 6, the Follower inverter immediately stabilizes the island with its proportional control. As soon as its deviations exceeds the limitations of the deadband, the integral parts (both voltage in (a) and frequency in (b)) are activated and drive the error to zero. This is done by providing the necessary active and reactive power as shown in Fig. 10 (c). After a specific period of time  $t_{f,stable} = 1$  s, the Follower's integral part is

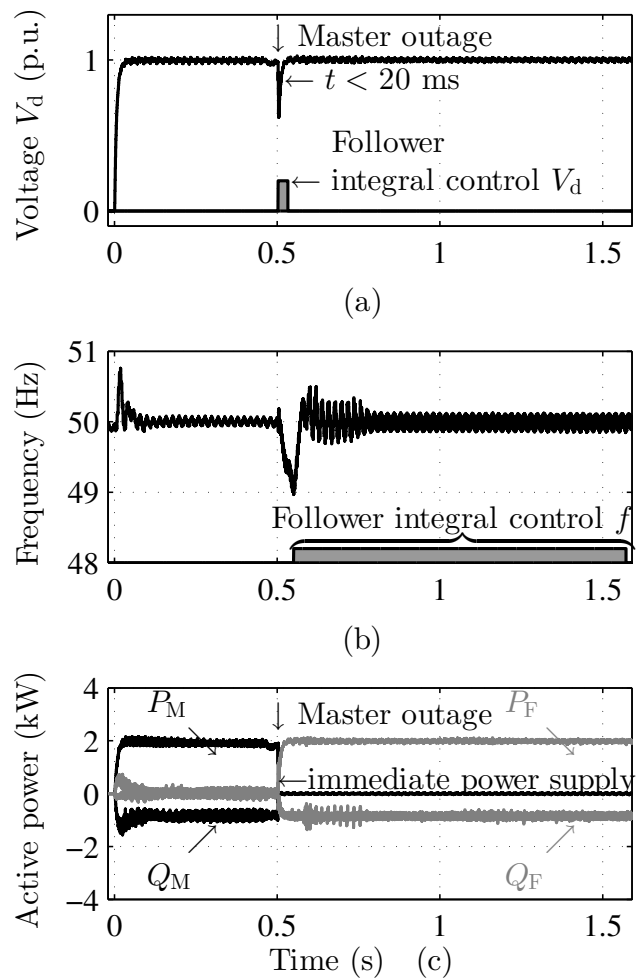

Fig. 10. The outage of the Master and take-over of the (former) Follower which stabilizes voltage (a) and frequency (b) by providing the necessary active and reactive power (c).

deactivated again. Naturally, there are some transients in both the voltage and frequency after the Master has tripped. But the transients can be handled very quickly. The voltage drop is shorter than 20 ms and thus is not assumed to be a problem for loads according to norm EN 50160 [27].

After the deactivation of the Follower's frequency integral term, the island frequency will deviate from nominal value again until it will be driven back to nominal value by a short activation of the Follower. A possible solution to overcome this undesired state could be that a Follower permanently takes over the Master's role. Another approach would be gradually reducing the size of the deadband in order to reduce the frequency variations as well.

### D. Countermeasures against Excess of Active Power

Fig. 11 shows the results for an islanding operation with a Master and an *old stock inverter*. The power ratings of the inverters are provided in Table III. The *old stock inverter* would like to provide twice as much active power as is needed by the load. Thus, if there is no control, the voltage would

TABLE II  
PARAMETERS FOR EXPERIMENT OF MASTER OUTAGE COMPENSATION.

Symbol	Description	Value
$P_M$	Active power of the Master	4 kW
$P_F$	Active power of the Follower	3 kW
$P_L$	Active power of the load	2 kW
$C_L$	Load parallel capacitor for reactive power	20 $\mu$ F
$\Delta V$	Voltage deviation when integral control is activated	0.05 $V_n$
$\Delta f$	Frequency deviation when integral control is activated	1 Hz

TABLE III  
PARAMETERS FOR EXPERIMENT OF EXCESS POWER CONTROL.

Symbol	Description	Value
$P_M$	Active power of the Master	2 kW
$P_S$	Active power of the old stock inverters	4 kW
$P_L$	Active power of the load	2 kW
$\frac{\Delta P_S}{\Delta t}$	Slew rate of the old stock inverters	500 $W \cdot s^{-1}$
$V_{max}$	Upper voltage limit	1.1 $V_n$
$V_{lim}$	Voltage level when limitation starts	1.05 $V_n$

finally exceed  $V_{max} = 1.1 V_n$  and the island is not able to survive in the long run. But with the algorithm proposed, those inverters that behave in accordance with the German grid codes [22] can be controlled indirectly by the Master by changing the islanding frequency.

After the Master has re-established the grid, the *old stock inverter* joins after  $t_{rec} = 1$  s and increases its active power with  $\frac{\Delta P_S}{\Delta t} = 500 W \cdot s^{-1}$ . When the *old stock inverter* increases its active power, the Master reduces its injection in order to keep the voltage at the desired value, see Fig. 11 (c). The Master finally reduces its power to zero but the *old stock inverter's* injection still rises, which increases the voltage, as shown in Fig. 11 (a). At  $t = 5.4$  s, the RMS voltage exceeds the control limit  $V_{lim} = 1.05 V_n$  and the frequency changing by the Master is activated. At  $t = 5.6$  s, the 50.2 Hz limit is reached and the *old stock inverter* immediately stops increasing the active power, as shown in Fig. 11 (c). Finally, an operating point is reached at about  $V = 1.06 V_n$  and  $f = 50.4$  Hz.

The results of Fig. 11 show that the indirect control of any *old stock inverter* by controlling the islanding frequency is effective and applicable for *old stock inverters* that are even much larger than the Master itself. The usage of RMS voltage for this control is more suitable than momentary voltage as it is more robust due to a low-pass filter behaviour.

## V. CONCLUSION

This paper presents a restoration strategy for the islanding operation of low-voltage distribution grids with distributed generation units. Although it is not based on communication, there are no steady state errors. The strategy is scalable and multiple generation units cooperate in order to maximize

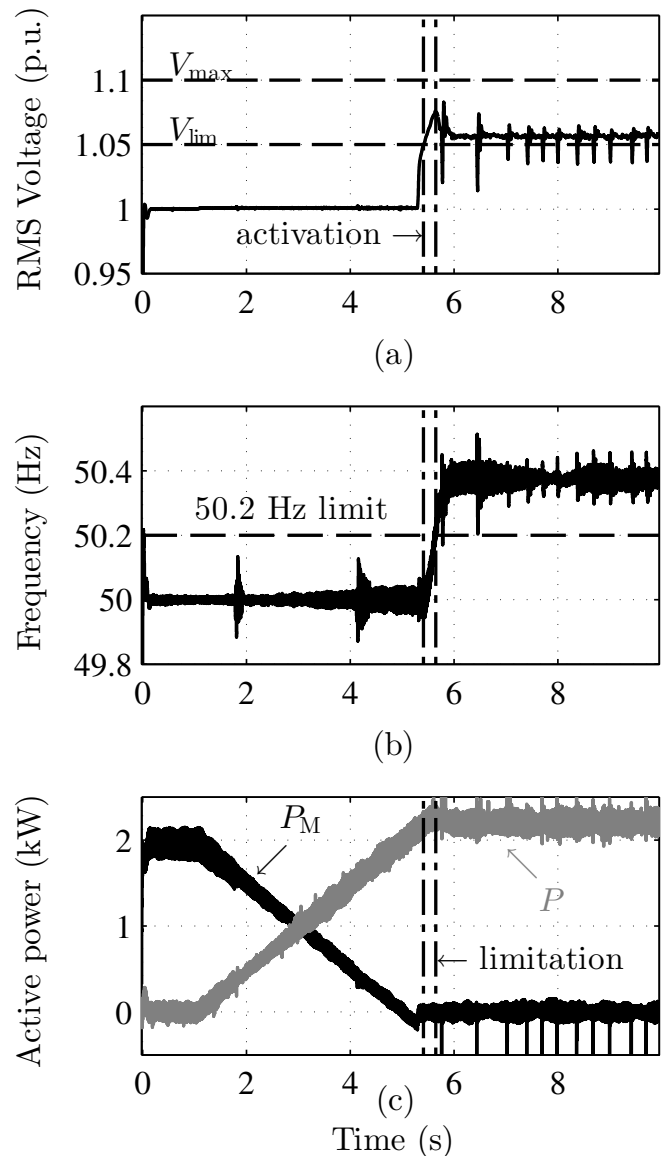

Fig. 11. Limitation of *old stock inverter's* output power by frequency change: (a): RMS voltage, (b): active power of Master  $P_M$  and *old stock inverter*  $P$ , (c): frequency. Left dotted-dashed line marks the activation of the frequency-changing algorithm, right dotted-dashed line marks the limitation of the *old stock inverter* due to excess of frequency limit at 50.2 Hz.

the chances of successful restoration. Even if the Master unit fails due to an outage, the other inverters are able to stabilize the system and maintain operation at nominal values. Furthermore, the proposed method is able to provide effective countermeasures against an excess of active power provided from non-controllable generation. This is a key feature to allow islanding operation in low-voltage grids, where the number of generation units can be quite high. The algorithm uses the fact that grid codes require *old stock inverters* to reduce their active power by 40%/Hz in case the frequency exceeds 50.2 Hz.

The effectiveness and robustness of the control has been verified by several experimental tests under linear and nonlinear

load conditions and for multiple inverter operation.

Future research is required for motor loads. Usually, motor loads trip after a voltage collapse and must be re-connected to the grid manually. Thus, it is likely that they will not affect the start-up process. But their re-connection will significantly change the connection between voltage/active power and frequency/reactive power. This will influence the control stability and thus should be in the focus of future research.

The results for constant power load operation showed that harmonic compensation will be of importance with increasing shares of non-linear loads. Possible solutions could be integrating harmonic load current feed-forward signals or shaping the inverter output impedance to make the inverter behave like a resistor for high-frequency currents.

Moreover, suitable protection schemes are crucial for a safe islanding operation. A reduced level of short-circuit currents might be challenging for future protection concepts.

Finally, this work does not yet contain a load sharing concept. This will be especially of interest if DG units are obliged to operate within certain boundaries.

## REFERENCES

- [1] X. Huang, Y. Yang, and G. A. Taylor, "Service restoration of distribution systems under distributed generation scenarios," *CSEE Journal of Power and Energy Systems*, vol. 2, no. 3, pp. 43–50, Sept 2016.
- [2] X. Chen, W. Wu, and B. Zhang, "Robust restoration method for active distribution networks," *IEEE Transactions on Power Systems*, vol. 31, no. 5, pp. 4005–4015, Sept 2016.
- [3] A. Elmitwally, M. Elsaid, M. Elgamal, and Z. Chen, "A fuzzy-multiagent service restoration scheme for distribution system with distributed generation," *IEEE Transactions on Sustainable Energy*, vol. 6, no. 3, pp. 810–821, July 2015.
- [4] C. L. Moreira, F. O. Resende, and J. A. P. Lopes, "Using low voltage microgrids for service restoration," *IEEE Transactions on Power Systems*, vol. 22, no. 1, pp. 395–403, Feb 2007.
- [5] T. T. H. Pham, Y. Besanger, and N. Hadjsaid, "New challenges in power system restoration with large scale of dispersed generation insertion," *IEEE Transactions on Power Systems*, vol. 24, no. 1, pp. 398–406, Feb 2009.
- [6] A. Nasiri, "Digital control of three-phase series-parallel uninterruptible power supply systems," *IEEE Transactions on Power Electronics*, vol. 22, no. 4, pp. 1116–1127, July 2007.
- [7] G. Escobar, P. Mattavelli, A. M. Stankovic, A. A. Valdez, and J. Leyva-Ramos, "An adaptive control for ups to compensate unbalance and harmonic distortion using a combined capacitor/load current sensing," *IEEE Transactions on Industrial Electronics*, vol. 54, no. 2, pp. 839–847, April 2007.
- [8] L. F. A. Pereira, J. V. Flores, G. Bonan, D. F. Coutinho, and J. M. G. da Silva, "Multiple resonant controllers for uninterruptible power supplies - a systematic robust control design approach," *IEEE Transactions on Industrial Electronics*, vol. 61, no. 3, pp. 1528–1538, March 2014.
- [9] X. Sun, Y.-S. Lee, and D. Xu, "Modeling, analysis, and implementation of parallel multi-inverter systems with instantaneous average-current-sharing scheme," *IEEE Transactions on Power Electronics*, vol. 18, no. 3, pp. 844–856, May 2003.
- [10] S. Shah and P. S. Sensarma, "Three degree of freedom robust voltage controller for instantaneous current sharing among voltage source inverters in parallel," *IEEE Transactions on Power Electronics*, vol. 25, no. 12, pp. 3003–3014, Dec 2010.
- [11] J.-F. Chen and C.-L. Chu, "Combination voltage-controlled and current-controlled pwm inverters for ups parallel operation," *IEEE Transactions on Power Electronics*, vol. 10, no. 5, pp. 547–558, Sep 1995.
- [12] W.-C. Lee, T.-K. Lee, S.-H. Lee, K.-H. Kim, D.-S. Hyun, and I.-Y. Suh, "A master and slave control strategy for parallel operation of three-phase ups systems with different ratings," in *Applied Power Electronics Conference and Exposition, 2004. APEC '04. Nineteenth Annual IEEE*, vol. 1, 2004, pp. 456–462 Vol.1.
- [13] Z. Liu, J. Liu, X. Hou, Q. Dou, D. Xue, and T. Liu, "Output impedance modeling and stability prediction of three-phase paralleled inverters with master-slave sharing scheme based on terminal characteristics of individual inverters," *IEEE Transactions on Power Electronics*, vol. 31, no. 7, pp. 5306–5320, July 2016.
- [14] Z. He and Y. Xing, "Distributed control for ups modules in parallel operation with rms voltage regulation," *IEEE Transactions on Industrial Electronics*, vol. 55, no. 8, pp. 2860–2869, Aug 2008.
- [15] J. Rocabert, A. Luna, F. Blaabjerg, and P. Rodriguez, "Control of power converters in ac microgrids," *IEEE Transactions on Power Electronics*, vol. 27, no. 11, pp. 4734–4749, Nov 2012.
- [16] S. J. Chiang, C. Y. Yen, and K. T. Chang, "A multimodule parallelable series-connected pwm voltage regulator," *IEEE Transactions on Industrial Electronics*, vol. 48, no. 3, pp. 506–516, Jun 2001.
- [17] Y. Zhang, M. Yu, F. Liu, and Y. Kang, "Instantaneous current-sharing control strategy for parallel operation of ups modules using virtual impedance," *IEEE Transactions on Power Electronics*, vol. 28, no. 1, pp. 432–440, Jan 2013.
- [18] E. A. A. Coelho, P. C. Cortizo, and P. F. D. Garcia, "Small-signal stability for parallel-connected inverters in stand-alone ac supply systems," *IEEE Transactions on Industry Applications*, vol. 38, no. 2, pp. 533–542, Mar 2002.
- [19] K. D. Brabandere, B. Bolsens, J. V. den Keybus, A. Woyte, J. Driesen, and R. Belmans, "A voltage and frequency droop control method for parallel inverters," *IEEE Transactions on Power Electronics*, vol. 22, no. 4, pp. 1107–1115, July 2007.
- [20] R. Majumder, G. Ledwich, A. Ghosh, S. Chakrabarti, and F. Zare, "Droop control of converter-interfaced microsources in rural distributed generation," *IEEE Transactions on Power Delivery*, vol. 25, no. 4, pp. 2768–2778, Oct 2010.
- [21] J. Loth, M. Dietmannsberger, and D. Schulz, *Implementation and Compatibility Analysis of Dynamic Voltage Support and Unintentional Islanding Capability of Power-Electronic Generators*. Wiesbaden: Springer Fachmedien Wiesbaden, 2017, pp. 146–152.
- [22] VDE, *Generators connected to the Low-Voltage Distribution Network, Technical requirements for the connection to and parallel operation with low-voltage distribution networks. In German: Erzeugungsanlagen am Niederspannungsnetz, Technische Mindestanforderungen für Anschluss und Parallelbetrieb von Erzeugungsanlagen am Niederspannungsnetz*, Verband der Elektrotechnik Elektronik Informationstechnik e.V. Std. VDE-AR-N 4105:2011-08, 2011.
- [23] *Standard for Interconnecting Distributed Resources with Electric Power Systems*, IEEE Std. 1547-2003, 2003.
- [24] *Recommended Practice for Utility Interface of Photovoltaic (PV) Systems*, IEEE Std. 929-2000, 1991.
- [25] S. S. T. AG, *Operating Parameters, SUNNY BOY, SUNNY MINI CENTRAL, WINDY BOY, Technical Description*, 6th ed., SMA Solar Technology AG, Niestetal, Germany, 2012, SB SMC WB Par TB TEN11316.
- [26] M. Liserre, F. Blaabjerg, and S. Hansen, "Design and control of an LCL-filter-based three-phase active rectifier," *IEEE Transactions on Industry Applications*, vol. 41, no. 5, pp. 1281–1291, Sept 2005.
- [27] VDE, *Voltage characteristics of electricity supplied by public distribution networks*, Verband der Elektrotechnik Elektronik Informationstechnik e.V. Std. EN 50 160:2011-02, 2011.