



Aalborg Universitet

AALBORG UNIVERSITY
DENMARK

Enhanced Frequency Droop Method for Load Sharing in LVDC Power Systems

Peyghami, Saeed; Davari, Pooya; Blaabjerg, Frede

Published in:

9th Annual International Power Electronics, Drive Systems, and Technologies Conference, PEDSTC 2018

DOI (link to publication from Publisher):

[10.1109/PEDSTC.2018.8343823](https://doi.org/10.1109/PEDSTC.2018.8343823)

Publication date:

2018

Document Version

Accepted author manuscript, peer reviewed version

[Link to publication from Aalborg University](#)

Citation for published version (APA):

Peyghami, S., Davari, P., & Blaabjerg, F. (2018). Enhanced Frequency Droop Method for Load Sharing in LVDC Power Systems. In *9th Annual International Power Electronics, Drive Systems, and Technologies Conference, PEDSTC 2018* (pp. 358-362). IEEE Press. <https://doi.org/10.1109/PEDSTC.2018.8343823>

General rights

Copyright and moral rights for the publications made accessible in the public portal are retained by the authors and/or other copyright owners and it is a condition of accessing publications that users recognise and abide by the legal requirements associated with these rights.

- ? Users may download and print one copy of any publication from the public portal for the purpose of private study or research.
- ? You may not further distribute the material or use it for any profit-making activity or commercial gain
- ? You may freely distribute the URL identifying the publication in the public portal ?

Take down policy

If you believe that this document breaches copyright please contact us at vbn@aub.aau.dk providing details, and we will remove access to the work immediately and investigate your claim.

Enhanced Frequency Droop Method for Load Sharing in LVDC Power Systems

Saeed Peyghami, Pooya Davari, and Frede Blaabjerg
Department of Energy Technology
Aalborg University
9220 Aalborg East, Aalborg, Denmark
{sap, pda, fbl}@et.aau.dk

Abstract— The main objectives of a load sharing control in dc power systems are proper power sharing among dc sources with an acceptable voltage regulation through the grid. Virtual resistor based droop methods also called voltage droop methods have low performance and accuracy. Hence, supervisory controllers reinforced by a communication system are required to improve the effectiveness of the voltage droop methods. Furthermore, frequency droop approaches have been presented for accurate load sharing control in dc power systems without utilizing a communication system. However, the ripples are superimposed on voltage and current waveforms affecting overall system efficiency and power quality. This paper proposes an Enhanced Frequency Droop Method (EFDM) to overcome the main drawbacks of the frequency droop approaches by stopping voltage superimposing at steady state. Preliminary simulation results show the effectiveness of the proposed approach.

Keywords— DC power system, Droop Method, Frequency Injection, Frequency Droop, Power Sharing.

I. INTRODUCTION

Low Voltage DC (LVDC) power systems, also called dc microgrids have become more popular in the last decades due to the advances in the power electronics as well as due to the importance of the energy security and efficiency. Both AC and DC microgrids encounter with the control, stability, operation, and protection issues since almost all dc sources are connected to the grid through power converters [1]–[5]. In order to control and operate dc power systems, a suitable power management system is required. The main objectives of the power management system are to properly share the load power among the converters and keep the voltage of the grid close to the rated value.

A hierarchical power management system has been presented in three levels including primary, secondary, and tertiary controllers [6]–[11]. A simple, but more reliable droop method is presented to appropriately control the load sharing among parallel dc sources. In this approach, the converters are using the voltage of common bus and the line resistances are usually neglected [11]–[14]. Therefore, with a small virtual resistor, an accurate load sharing can be achieved. However, considering the effect of line resistance, large virtual resistors are required in order to carry out the appropriate load sharing. However, the large virtual resistors cause large voltage variation within the microgrid, which usually are regulated by utilizing a secondary controller reinforced by a communication system [6], [8], [10], [15].

Employing communication links in the control system may affect the overall system reliability and stability. Hence some approaches have been presented to carry out the power

management objectives without utilizing any physical communication system [4], [16]–[21].

In [16], where a power sharing method based on frequency encoding of the output current of dc sources has been presented which requires no communication system. In another technique, in [17], dc sources “talk” to each other by modulating their respective power levels without using communication system. This approach is however prone to grid parameter changes. Furthermore, the bandwidth of the control system is low, hence it is only suitable for tertiary level. A frequency-based load sharing approach presented in [18] and [19], and reapplied to dc systems in [20], using the same principles of droop controller, while meeting some fundamental issues discussed in [22].

The frequency droop approach for dc power systems, named as Synchronverter-Enabled DC Power Sharing Approach (SEDCPSA), is presented in [4] employing the same principles of the load sharing among synchronous generators. SEDCPSA imposes ac ripples on the voltage and current of converters. To reduce the current ripples as well as improving the dynamic stability of the frequency droop method, the modified frequency droop approach is further presented in [21]. However, the voltage and current ripples still remain even though the modified approach is employed, which may affect the system efficiency and power quality.

In order to overcome the aforementioned issues (lower efficiency and power quality due to the superimposed voltage and current ripples), an Enhanced Frequency Droop Method (EFDM) is proposed in this paper. The concept of the frequency droop approach is similar to the modified frequency droop presented in [21], where each converter superimposes a small ac voltage to the dc voltage with a frequency proportional to the corresponding output current. Hence, the converters can be coordinated together like the droop-controlled synchronous generators in the conventional power systems. Meanwhile, the EFDM proposes to stop the ac voltage injection at the steady state condition. Therefore, employing the EFDM not only insures proper power sharing but also eliminates the voltage and current ripples at steady state, which results in improved efficiency and power quality in the system.

The remaining part of this paper is organized as follows. Section II explains the detailed control system of frequency droop approach, and the proposed EFDM is presented in Section III. The preliminary simulation results validating the performance of the control system are given in Section IV, further simulations and efficiency evaluation will be given in the final version. Finally Section V summarizes the achievements.

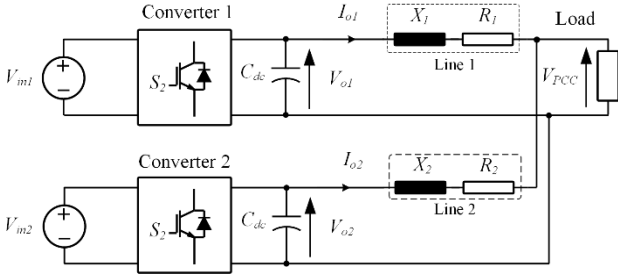

Fig. 1. Simplified dc grid with two converters and a localized load.

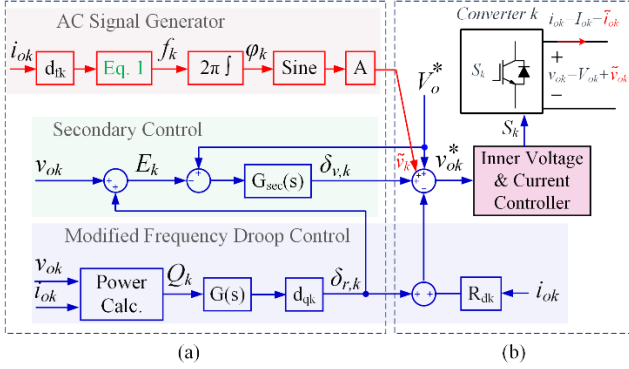

Fig. 2. Block diagram of the modified frequency droop control, (a) Enhanced Frequency Droop Controller, and (b) inner controllers and virtual resistor [21].

II. MODIFIED FREQUENCY DROOP METHOD

The modified frequency droop control approach has been presented in [21]. Here, the approach is explained for a simplified dc system shown in Fig. 1, where two dc-sources connected to a load through dc-dc converters. The modified control system for each converter is shown in Fig. 2 and explained in the following.

To ensure appropriate load sharing between converters, a small ac voltage is added to the output dc voltage of each converter. The frequency of the ac voltage of each converter is proportional to the corresponding output current (/power), which can be defined as:

$$f_k = f^* - d_{fk} i_{ok}, \quad (1)$$

where f^* and f_k are the nominal and injected frequency, i_{ok} is the output current and d_{fk} is the frequency droop coefficient, and k denotes the k^{th} converter. The superimposed ac voltage causes ac current flow through the grid which is proportional to the phase angle (φ_k) of the ac voltages as well as the line impedances. According to Fig. 2 (a), the phase angle of the ac voltage of the k^{th} converter can be found as:

$$\varphi_k(t) = \int_{\tau=0}^t 2\pi f_k \tau d\tau. \quad (2)$$

Considering the constant ac voltage amplitude (i.e., A), and the line impedances to be negligible in comparison to the load impedance, the ac current flowing between the two converters \tilde{i}_{o1} and \tilde{i}_{o2} can be found as:

$$\tilde{i}_{o1} \approx \frac{A\angle\varphi_1 - A\angle\varphi_2}{R_1 + R_2 + j(X_1 + X_2)} = -\tilde{i}_{o2} \quad (3)$$

Selecting the ac voltage frequency to be around 50 Hz, the line reactance can be neglected [23]. Hence, the ac currents can be simplified as:

$$\tilde{i}_{o1} \approx \frac{A\angle\varphi_1 - A\angle\varphi_2}{R_1 + R_2} = -\tilde{i}_{o2} \quad (4)$$

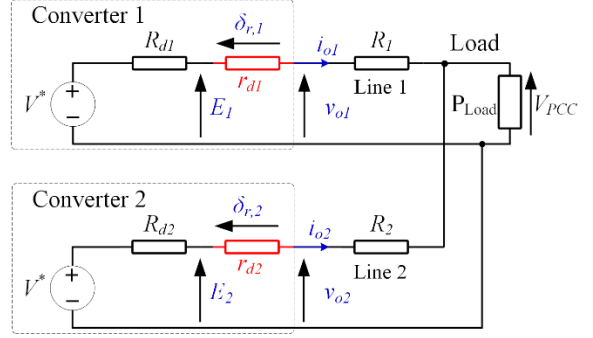

Fig. 3. Electrical equivalent model of the simplified dc grid with two DGs and a localized load.

According to (4), the ac currents are proportional to voltage phase angles and inversely proportional to the line resistances. Furthermore, following (1), phase angles are proportional to the output currents. Therefore, the ac currents can be employed to make a communication between the converters like frequency droop principles in ac systems. As a result, considering same frequencies for the converters at steady state, the ratio of the output current of the converters (ξ) based on (1) can be found as:

$$\frac{i_{o1}}{i_{o2}} = \frac{d_{f2}}{d_{f1}} = \xi. \quad (5)$$

Therefore, the output currents of the converters can be shared inversely proportional to the droop coefficients. This concept has basically been used in droop controlled synchronous generators, where the real power of generators can be controlled by employing a common frequency of the grid. Here, in the dc grid, to reach a same frequency for the converters, it is required to control an ac power. Meanwhile, in LV power systems, the reactive power is proportional to the frequency [23]–[25]. Hence, the reactive power shared between the converters can be used to reach the same frequency in the grid.

The ac reactive power is proportional to the ac currents and hence the phase angles. Furthermore, the phase angles are related to the dc currents, which can also be controlled by the dc voltages. Therefore, adjusting the dc voltages based on the reactive power can control the output dc current. Therefore, following Fig. 2, the dc voltage reference can be modified as:

$$v_{ok}^* = V^* - R_{dk} i_{ok} + \delta_{r,k}, \quad (6)$$

$$\delta_{r,k} = d_{qk} G(s) Q_k,$$

where d_{qk} is the voltage coupling coefficient, and $G(s)$ is a first order low pass. Also, R_{dk} denotes the conventional droop coefficient (virtual resistor) and it can be defined as:

$$R_{dk} = \frac{\Delta V}{I_{n,k}}, \quad (7)$$

where ΔV is the allowable dc voltage variation, and $I_{n,k}$ is the nominal current of the k^{th} converter. Therefore, the relationship between the output current of converters (I_1, I_2) at the steady state can be found as:

$$\frac{I_1}{I_2} = \frac{I_{n,1}}{I_{n,2}} = \frac{R_{d2}}{R_{d1}} = \xi. \quad (8)$$

The equation (6) can be rearranged as:

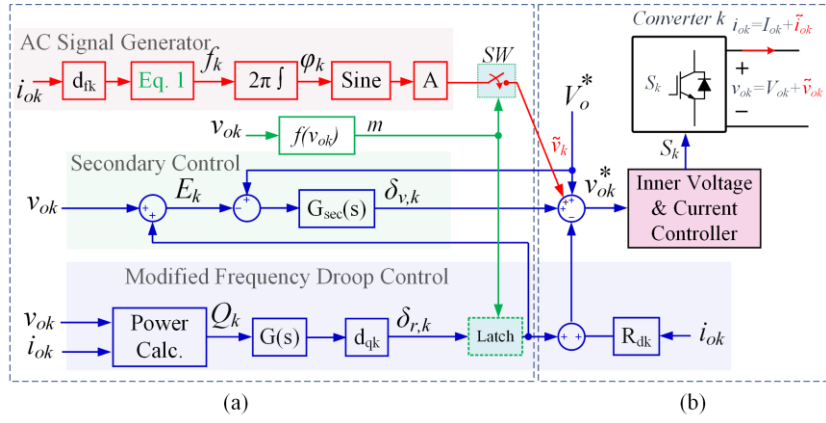

Fig. 4. Block diagram of the proposed control system, (a) Enhanced Frequency Droop Controller, and (b) inner controllers and virtual resistor.

$$v_{ok}^* = V^* - R_{dk}i_{ok} + \frac{d_{pk}G(s)Q_k}{i_{ok}}i_{ok}, \quad (9)$$

$$v_{ok}^* = V^* - R_{dk}i_{ok}, \quad (10)$$

where R_{dk} is the resultant virtual resistor of k^{th} converter, and it can be adapted based on corresponding loading conditions and can be defined as:

$$R_{dk} = R_{dk} + \frac{d_{pk}G(s)Q_k}{i_{ok}}. \quad (11)$$

Defining the variable term of virtual resistor in (11) as:

$$r_{dk} := \frac{d_{pk}G(s)Q_k}{i_{ok}}, \quad (12)$$

The steady state electrical model of the system can be represented as shown in Fig. 3. The system model contains conventional droop coefficient (virtual resistor), adaptive droop gain, and line resistor. From the electric circuit theory, the internal voltage of converters denoted by E_k in Fig. 3, can be written as:

$$\begin{cases} E_1 = V^* - R_{d1}I_1 \\ E_2 = V^* - R_{d2}I_2 \end{cases}. \quad (13)$$

Based on (8), the voltage drops on the virtual resistors (R_{d1}, R_{d2}) at the steady state are equal, and hence, following (13), the internal voltage of both converters are the same. Therefore, it can be estimated and controlled by the secondary regulator. By measuring the output voltage (v_{ok}) and calculating the correction term ($\delta_{r,k}$), the internal voltage (E_k) can be found as:

$$E_k = v_{ok} + \delta_{r,k}. \quad (14)$$

Therefore, the secondary correction term ($\delta_{v,k}$) can be generated by a PI controller ($G_{sec}(s)$) to regulate the internal voltage at the reference value as:

$$\delta_{v,k} = (V^* - E_k)G_{sec}(s). \quad (15)$$

According to Fig. 2, the reference voltage of the k^{th} converter can be calculated as:

$$v_{ok}^* = V^* + \delta_{v,k} - \delta_{r,k} - R_{dk}i_{ok}. \quad (16)$$

Considering the fast dynamic response for the internal voltage and current control loops in comparison to the secondary layer, the output voltage of the converter can properly track the reference value, and hence,

$$v_{ok}^* = v_{ok} = V^* - \frac{I}{I + G_{sec}(s)}R_{dk}i_{ok} - d_qG(s)Q_k. \quad (17)$$

Considering a PI regulator for secondary controller ($G_{sec}(s)$), the term $1/(1+G_{sec}(s))$ in (17), is vary small at steady state. Hence, the secondary controller employing the local voltage and current information can compensate the voltage drop on the virtual resistor.

III. PROPOSED ENHANCED FREQUENCY DROOP METHOD (EFDM)

The proposed control system called EFDM, is shown in Fig. 4. The basic concept of the control approach is similar to the modified droop control discussed in Section II. Once the power sharing objectives are achieved, and the voltage and current waveforms are settled at the steady state value, the control system stops superimposing the ac voltage and latches the steady state value of $\delta_{r,k}$. Therefore, the converters can properly operate in parallel to support the load. However, a value of $\delta_{r,k}$ is associated with a specified load. Hence, when the load is changed a new value of $\delta_{r,k}$ should be obtained. Connecting or disconnecting a load will change the voltage of the system for a short time before accomplishing the secondary voltage regulation. Therefore, whenever there is a change in the converter output, the frequency droop control system will be re-activated to calculate the new $\delta_{r,k}$.

The switch SW in Fig. 4(a) is closed if $m = 1$, where

$$m = f(v_{ok}) = \begin{cases} 1 & \left| \frac{v_{ok} - v_{ok}^{ss}}{v_{ok}^{ss}} \right| \geq 0.02 \\ 0 & \text{otherwise} \end{cases}, \quad (18)$$

and hence, the ac voltage is superimposed to the dc voltage. Whenever the output voltage v_{ok} variation goes higher than of 2% of the latest corresponding steady state value v_{ok}^{ss} , the value of m changes to one. Meanwhile, frequency droop controller properly controls the load sharing and voltage regulation by means of frequency droop principle as

explained in Section II. When the voltage and current values are settled at a steady state value, the term m changes to “0”. Once m equals to zero, the block “latch” in Fig. 4 keeps the last value of $\delta_{r,k}$.

Employing the EFDM, the voltage and current ripples will be removed at the steady state, hence the efficiency and power quality of the system is increased, and the proper load sharing and voltage regulation can be achieved without using any physical communication links.

IV. SIMULATION RESULTS

In order to demonstrate the viability of the proposed approach, a simplified microgrid with two boost converters, like the one shown in Fig. 1 is considered. The control and converter parameters are given in Table I.

The simulation results are shown in Fig. 5 and Fig. 6 for frequency droop method and EFDM, respectively. Load change is considered as a disturbance occurred at t_1 and the performance of the proposed control system is compared to the frequency droop presented in [21]. As shown in Fig. 5(a), the load is suitably shared among the converters. Furthermore, the output voltage of converters are regulated close to the reference value 400 V. Hence, the frequency droop control [21] can properly carry out the load sharing and voltage regulation in the dc microgrid. However, as it can be seen in these results, both the voltage and current waveforms have ripples at steady state, which can affect the efficiency and power quality of the microgrid.

Employing the proposed EFDM can appropriately fulfill the power management objectives including load sharing and voltage regulation as shown in Fig. 6(a) and (b) respectively like the frequency droop approach presented in [21]. The system is operating with a 1.6 KW load. At t_1 another 1.6 KW load is connected to the system. when the voltage drops under the threshold value i.e., 98% of previous steady state value, the converters start to inject an ac voltage. The load sharing is properly carried out and once the voltages and currents reach the steady state value, the signal injection is stopped. Therefore, at the steady state, the current and voltage waveforms are ripple-free without affecting the load sharing performance. As a result, the power quality and efficiency of the system can be improved in comparison to the frequency droop methods. In the final version, more simulations and efficiency analysis will be provided.

TABLE I: SPECIFICATIONS OF THE SIMULATED DC GRID AND CONTROL SYSTEM

Definition	Symbol	Value
Injected frequency	f^* (Hz)	50
Frequency-current droop	d_n, d_{j2} (Hz/A)	0.3, 0.3
Virtual Resistor	R_v (Ω)	5
Superimposed ac voltage	A (V)	2.5
Voltage-power coupling	d_q (V/VAR)	25
DC link voltage	V_{dc} (V)	400
Inner controllers	Voltage controller	$0.45 + 20/s$
	Current controller	$0.05 + 2/s$
Secondary regulator	Voltage regulator	$0.88 + 8.6/s$
Load	P_{load} (kW)	2×1.6
Impedance of line 1	$r_1(\Omega) + jL_1(\mu H)$	$1 + j180$
Impedance of line 2	$r_2(\Omega) + jL_2(\mu H)$	$2 + j280$
Converter Parameters	L_{dc} (mH)	2
	C_{dc} (μF)	500

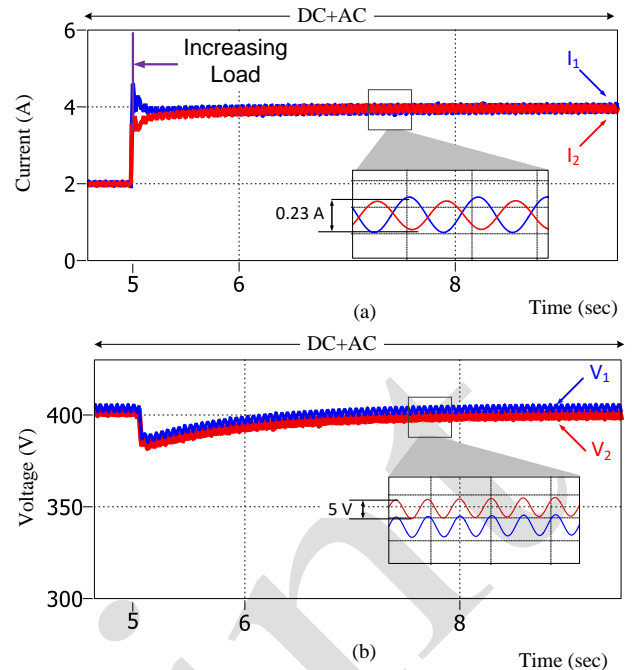

Fig. 5. Simulation results of Case I: Frequency Droop Method, (a) output currents of converters, (b) output voltages of converters.

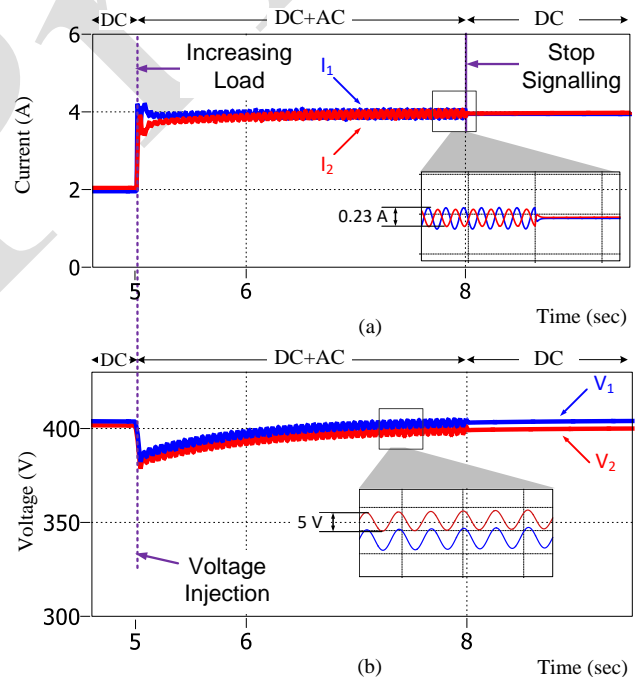

Fig. 6. Simulation results of Case II: Enhanced Frequency Droop Method, (a) output currents of converters, (b) output voltages of converters.

V. CONCLUSION

This paper presents an Enhanced Frequency Droop Method (EFDM) for power sharing control in LVDC power systems. Frequency droop methods superimpose small ripples on output voltages and currents of converters and improve the power sharing and voltage regulation accuracy in LVDC power systems without utilizing any physical communication links among converters. However, it deteriorates the power quality and efficiency of the system. In order to overcome the mentioned issues, the proposed EFDM improves the system efficiency and power quality by

stopping the signal injection after transients. Simulation results show the effectiveness of the proposed approach. Therefore, the EFDm can accurately control the power sharing among the converters and regulates the voltages close to the nominal value without utilizing any communication links – which affects the reliability – as well as improve the performance of the frequency droop approach. As a result, the overall system efficiency, power quality, and reliability can be improved. Further simulations will be provided in the final version.

REFERENCES

- [1] B. T. Patterson, "DC, Come Home: DC Microgrids and the Birth of the 'Enernet,'" *IEEE Power Energy Mag.*, vol. 10, no. 6, pp. 60–69, 2012.
- [2] D. Boroyevich, I. Cvetkovic, R. Burgos, and D. Dong, "Intergrid: A Future Electronic Energy Network?," *IEEE J. Emerg. Sel. Top. Power Electron.*, vol. 1, no. 3, pp. 127–138, 2013.
- [3] P. Fairley, "DC Versus AC: The Second War of Currents Has Already Begun [In My View]," *IEEE Power Energy Mag.*, vol. 10, no. 6, pp. 104–103, Nov. 2012.
- [4] S. Peyghami, P. Davari, H. Mokhtari, P. C. Loh, and F. Blaabjerg, "Synchronverter-Enabled DC Power Sharing Approach for LVDC Microgrids," *IEEE Trans. Power Electron.*, vol. 32, no. 10, pp. 8089–8099, Oct. 2017.
- [5] F. Blaabjerg, Y. Yang, D. Yang, and X. Wang, "Distributed Power-Generation Systems and Protection," *Proc. IEEE*, vol. 105, no. 7, pp. 1311–1331, Jul. 2017.
- [6] V. Nasirian, A. Davoudi, F. L. Lewis, and J. M. Guerrero, "Distributed Adaptive Droop Control for Dc Distribution Systems," *IEEE Trans. Energy Convers.*, vol. 29, no. 4, pp. 944–956, 2014.
- [7] S. Moayedi and A. Davoudi, "Distributed Tertiary Control of DC Microgrid Clusters," *IEEE Trans. Power Electron.*, vol. 31, no. 2, pp. 1717–1733, 2015.
- [8] Q. Shafiee, T. Dragicevic, J. C. Vasquez, and J. M. Guerrero, "Hierarchical Control for Multiple DC-Microgrids Clusters," *IEEE Trans. Energy Convers.*, vol. 29, no. 4, pp. 922–933, 2014.
- [9] T. Dragicevic, J. M. Guerrero, J. C. Vasquez, and D. Skrllec, "Supervisory Control of an Adaptive-Droop Regulated DC Microgrid with Battery Management Capability," *IEEE Trans. Power Electron.*, vol. 29, no. 2, pp. 695–706, 2014.
- [10] S. Anand, B. G. Fernandes, and J. M. Guerrero, "Distributed Control to Ensure Proportional Load Sharing and Improve Voltage Regulation in Low-Voltage DC Microgrids," *IEEE Trans. Power Electron.*, vol. 28, no. 4, pp. 1900–1913, 2013.
- [11] J. M. Guerrero, J. C. Vasquez, J. Matas, L. G. De Vicuña, and M. Castilla, "Hierarchical Control of Droop-Controlled AC and DC Microgrids - A General Approach toward Standardization," *IEEE Trans. Ind. Electron.*, vol. 58, no. 1, pp. 158–172, 2011.
- [12] D. Chen, L. Xu, and L. Yao, "DC Voltage Variation Based Autonomous Control of DC Microgrids," *IEEE Trans. Power Deliv.*, vol. 28, no. 2, pp. 637–648, 2013.
- [13] A. Khorsandi, M. Ashourloo, and H. Mokhtari, "A Decentralized Control Method for a Low-Voltage DC Microgrid," *IEEE Trans. Energy Convers.*, vol. 29, no. 4, pp. 793–801, 2014.
- [14] D. Chen and L. Xu, "Autonomous DC Voltage Control of a DC Microgrid with Multiple Slack Terminals," *IEEE Trans. Power Syst.*, vol. 27, no. 4, pp. 1897–1905, Nov. 2012.
- [15] X. Lu, J. M. Guerrero, K. Sun, and J. C. Vasquez, "An Improved Droop Control Method for DC Microgrids Based on Low Bandwidth Communication With DC Bus Voltage Restoration and Enhanced Current Sharing Accuracy," *IEEE Trans. Power Electron.*, vol. 29, no. 4, pp. 1800–1812, Apr. 2014.
- [16] D. Perreault, R. Selders, and J. Kassakian, "Frequency-Based Current-Sharing Techniques for Paralleled Power Converters," *IEEE Trans. Power Electron.*, vol. 13, no. 4, pp. 626–634, 1998.
- [17] M. Angjelijinoski, C. Stefanovic, P. Popovski, H. Liu, P. C. Loh, and F. Blaabjerg, "Multiuser Communication through Power Talk in DC MicroGrids," *IEEE J. Sel. Areas Commun.*, vol. 34, no. 7, pp. 2006–2021, Jul. 2015.
- [18] A. Tuladhar, H. Jin, T. Unger, and K. Mauch, "Control of Parallel Inverters in Distributed AC Power Systems with Consideration of Line Impedance Effect," *IEEE Trans. Ind. Appl.*, vol. 36, no. 1, pp. 131–138, 2000.
- [19] A. Tuladhar, H. Jin, T. Unger, and K. Mauch, "Parallel Operation of Single Phase Inverter Modules with No Control Interconnections," in *Proc. IEEE APEC*, 1997, vol. 1, pp. 94–100.
- [20] A. Tuladhar and H. Jin, "A Novel Control Technique to Operate DC/DC Converters in Parallel with No Control Interconnections," in *Proc. IEEE PESC*, 1998, vol. 1, pp. 892–898.
- [21] S. Peyghami, H. Mokhtari, and F. Blaabjerg, "Decentralized Load Sharing in an LVDC Microgrid with an Adaptive Droop Approach Based on a Superimposed Frequency," *IEEE J. Emerg. Sel. Top. Power Electron.*, vol. 5, no. 3, pp. 1205–1215, 2017.
- [22] S. Peyghami, H. Mokhtari, P. C. Loh, P. Davari, and F. Blaabjerg, "Distributed Primary and Secondary Power Sharing in a Droop-Controlled LVDC Microgrid with Merged AC and DC Characteristics," *IEEE Trans. Smart Grid*, no. To be Published, DOI: 10.1109/TSG.2016.2609853, 2016.
- [23] J. Rocabert, A. Luna, F. Blaabjerg, and P. Rodriguez, "Control of Power Converters in AC Microgrids," *IEEE Trans. Power Electron.*, vol. 27, no. 11, pp. 4734–4749, 2012.
- [24] H. Nikkhajoei and R. Iravani, "Steady-State Model and Power Flow Analysis of Electronically-Coupled Distributed Resource Units," *IEEE Power Eng. Soc. Gen. Meet. PES*, vol. 22, no. 1, pp. 721–728, Jan. 2007.
- [25] J. M. Guerrero, L. Garcia de Vicuña, J. Matas, M. Castilla, and J. Miret, "Output Impedance Design of Parallel-Connected UPS Inverters With Wireless Load-Sharing Control," *IEEE Trans. Ind. Electron.*, vol. 52, no. 4, pp. 1126–1135, Aug. 2005.