



AALBORG UNIVERSITY
DENMARK

Aalborg Universitet

Improving 9-150 kHz EMI Performance of Single-Phase PFC Rectifier

Davari, Pooya; Hoene, Eckart; Zare, Firuz; Blaabjerg, Frede

Published in:

Proceedings of CIPS 2018 - 10th International Conference on Integrated Power Electronics Systems

Publication date:
2018

Document Version
Accepted author manuscript, peer reviewed version

[Link to publication from Aalborg University](#)

Citation for published version (APA):

Davari, P., Hoene, E., Zare, F., & Blaabjerg, F. (2018). Improving 9-150 kHz EMI Performance of Single-Phase PFC Rectifier. In *Proceedings of CIPS 2018 - 10th International Conference on Integrated Power Electronics Systems* (pp. 512-517). VDE Verlag GMBH. <https://ieeexplore.ieee.org/document/8403185/>

General rights

Copyright and moral rights for the publications made accessible in the public portal are retained by the authors and/or other copyright owners and it is a condition of accessing publications that users recognise and abide by the legal requirements associated with these rights.

- ? Users may download and print one copy of any publication from the public portal for the purpose of private study or research.
- ? You may not further distribute the material or use it for any profit-making activity or commercial gain
- ? You may freely distribute the URL identifying the publication in the public portal ?

Take down policy

If you believe that this document breaches copyright please contact us at vbn@aub.aau.dk providing details, and we will remove access to the work immediately and investigate your claim.

Improving 9-150 kHz EMI Performance of Single-Phase PFC Rectifier

Pooya Davari¹, Eckart Hoene², Firuz Zare³, Frede Blaabjerg¹

¹ Department of Energy Technology, Aalborg University, Alaborg, Denmark

² Fraunhofer IZM, Berlin, Germany

³ The University of Queensland, Brisbane, Australia

Email: pda@et.aau.dk, Eckart.hoene@izm.fraunhofer.de, f.zare@uq.edu.au, fbl@et.aau.dk

Abstract

In order to improve the Electromagnetic Interference (EMI) performance of grid-connected power electronics converters within the new 9-150 kHz frequency range, this digest investigates feasible solutions through modifying the EMI filter and applying spectral shaping method. The proposed solutions are validated based on a 1 kW single-phase Power Factor Correction (PFC) rectifier prototype. Moreover, frequency domain modeling approach is utilized as a virtual-oriented methodology in order to analyze the converter behavior and provide fast prototyping.

1 Introduction

The global shift of energy paradigm to carbon-free technologies has dramatically increased the penetration of grid-tied power electronics systems. However, the pulse energy conversion of power electronic converters and necessity of communicating along the power line leads to serious harmonic emission interferences, which cause the power grid to operate in an unpredictable and undesirable fashion. Although standard regulations are in place to make power electronics systems compatible with power grid operation, but extensive penetration and complex interaction among power electronics systems can become one of the main obstacles in enabling green energy generation and consumption.

Standard limits are set based on the reported disturbance incidents on the power grid over the years in order to protect sensitive equipment and control emitted harmonics from noise sources. As it is shown in **Figure 1**, while frequency ranges below 2 kHz and above 150 kHz are well covered with multitude standards, there are no general standards for the 2-150 kHz range [1], [2]. Recently, the

number of reported disturbances caused by this emission range is growing. The main reason that this frequency range has gained a lot of attention than before is the extensive penetration of the Pulse-Width Modulated (PWM) converters and Main Communication System (MCS) due to their technological advancement and significant market price reduction, which has increased the harmonic emission interferences within this range. Consequently, International Electrotechnical Commission (IEC) the world leading authority to prepare technical documents for international standards has requested international experts to define standardization for harmonics within the frequency range of 2 kHz-150 kHz [1].

According to the IEC Technical Committee 77A (TC77A) activity, the 2-150 kHz range was split to two main frequency bands (i.e., 2-9 kHz and 9-150 kHz). The influence of PWM converters on these frequency bands mainly depends on the type of the converter and its switching frequency. For instance, currently low power active rectifiers operates at frequencies above 9 kHz, while medium and high power PWM rectifiers operates at switching frequency below 9 kHz.

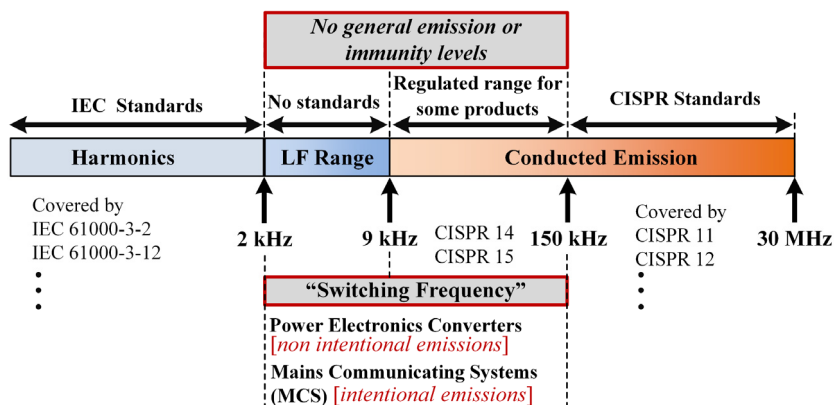

Figure 1 Harmonic and conducted EMI frequency ranges classified by IEC for distribution networks

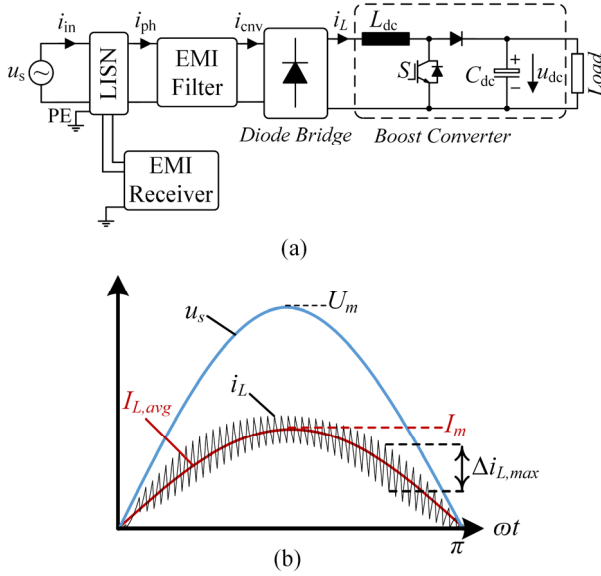

Figure 2 Implemented PFC rectifier, (a) overall structure of the system, (b) typical current waveform in CCM

Giving the fact that MCS mainly utilizes frequency band between 30 kHz to 150 kHz, the 9-150 kHz frequency range has gained more interest. This paper investigates feasible approaches in controlling the generated high frequency harmonics in single-phase PFC rectifier (see **Figure 2**). The main goal in this work is to address simple but effective approaches to improve the EMI performance of a rectifier with a Differential Mode (DM) EMI filter that is originally designed to meet standard limits for frequency ranges of above 150 kHz. Furthermore, a frequency domain approach is utilized which model the EMI behavior up to 150 kHz as a virtual-oriented methodology.

2 EMI Simulation (9 – 150 kHz)

Modeling and predicting conducted EMI is of significant importance, as it not only gives the ability to evaluate the high frequency current injected from PFC converter to the grid, but also it reduces time-to-market. Moreover, using this virtual-oriented methodology it is possible to optimize the filtering parameters.

Conducted EMI modeling is well covered in the literature through time-domain and frequency-domain approaches [3], [4]. In order to predict the conducted EMI, the measurement setup needs to be modeled following the EMC standard recommendations. In this section modeling of two important parts of the measurement setup, Line Impedance Stabilization Network (LISN) and EMI receiver are briefly addressed. Notably, in this work the frequency range of interest is below 150 kHz, which makes it different than prior introduced methods.

2.1 LISN/AMN

LISN or as stated in the new version of the IEC standards Artificial Mains Network (AMN) provides three important features of (a) high frequency decoupling between the

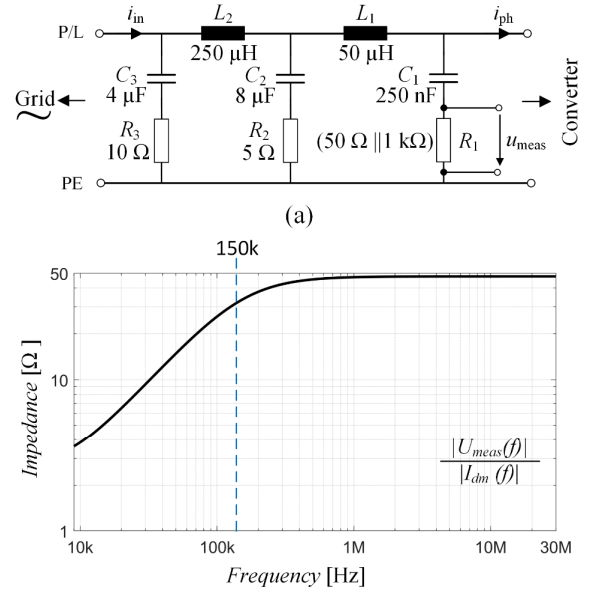

Figure 3 Band A LISN/AMN according to CISPR16, (a) LISN circuit per line, (b) impedance frequency behavior of LISN for DM converter input current i_{dm}

power converter and the mains, (b) fixed impedance for line and ground currents and (c) repeatable measurement. **Figure 3(a)** shows the circuit diagram of LISN following CISPR16 [5] for the $f > 9$ kHz. The noise voltage u_{meas} measured in time-domain is transformed to frequency domain using Faster Fourier Transformation (FFT) for further analysis. Here, the 50 Ω resistance represent the EMI receiver impedance. **Figure 3(b)** illustrates the LISN transfer function. Notably, for the $f < 150$ kHz the LISN impedance is not fixed at ≈ 50 Ω.

2.2 EMI Receiver

The second part, which needs to be implemented for EMI prediction, is the EMI receiver model. **Figure 4(a)** illustrates overall structure of the EMI receiver. In fact, the exact modeling of the EMI receiver due to lack of information from the manufacturers is not a trivial task and requires significant effort. Therefore, here as it is recommended in [3], [4] a simplified version has been considered for modeling. The band-pass filter, which is known as Resolution Bandwidth (RBW) filter, affects the magnitude of EMI emissions when it is applied to the spectrum of the measured voltage at LISN. This is due to the fact that the bandwidth of this filter (i.e., BW_{RBW}) is defined according to the frequency band of interest following the standard regulations.

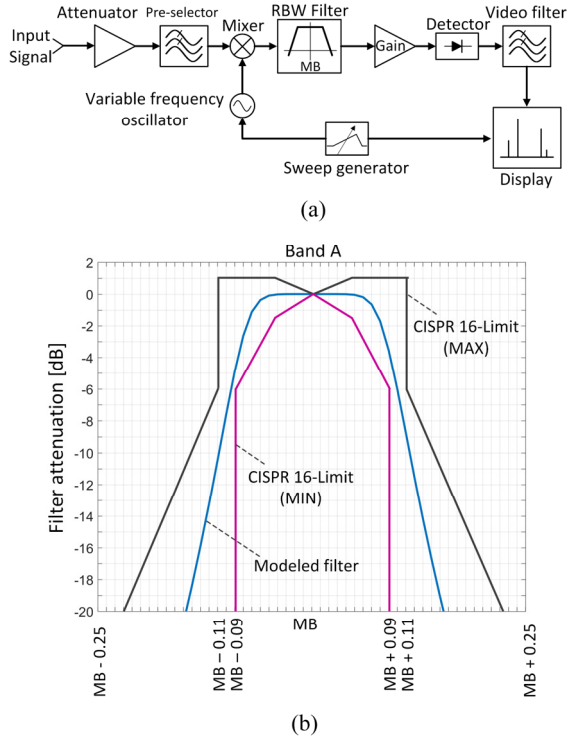

Figure 4 (a) Overall structure of the EMI receiver [5], (b) characteristics of Band A RBW filter following CISPR 16 standard

For instance, for Band A (9 – 150 kHz) $BW_{RBW} = 200$ Hz while for Band B (150 kHz – 30 MHz) measurements $BW_{RBW} = 9$ kHz. **Figure 4(b)** shows the maximum and minimum limits of RBW filter following CISPR16 standard [5] for Band A measurement. Notably, in order to model the RBW filter a 4th order Butterworth filter is used. In practice, the RBW filter center frequency (MB) is fixed and the EMI receiver mixer and oscillator adapts the spectrum of the measured voltage according to the center frequency. However, following [4] in order to omit modeling of the mixer and oscillator, the center frequency of RBW filter can be shifted over the frequency band of interest using frequency sweep (f_{sweep}). Utilizing the following equation the peak (U_{max}) EMI emission can be predicted [3]:

$$U_{max}(f_{sweep})[dB\mu V] = 20 \log \left[\frac{1}{1\mu V} \sum_{f=f_{sweep}-\frac{BW_{RBW}}{2}}^{f=f_{sweep}+\frac{BW_{RBW}}{2}} U_{meas}(f).RBW(f) \right] \quad (1)$$

Figure 5 exemplifies the peak measurement procedure following (1). Finally, a gain of $1/\sqrt{2}$ should be considered as the *Gain* in **Figure 4(a)**.

3 Proposed Solutions

The main goal in this paper is to investigate the feasible solutions to adapt the PFC rectifier EMI performance (original designed for Band B limits) to the new frequency Band A limits. In order to validate the EMI emission of the PFC rectifier shown in **Figure 2**, the CISPR11-A limit [6] is

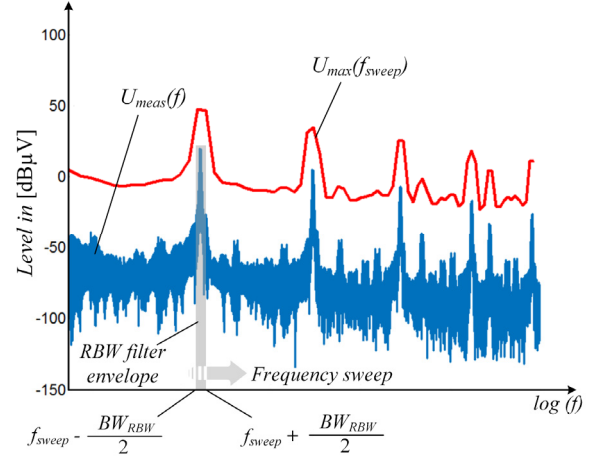

Figure 5 Conceptual illustrations of the applied peak measurement approach in frequency domain [3]

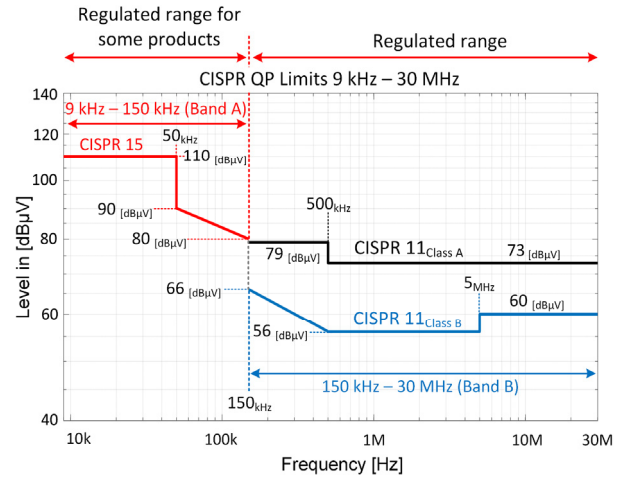

Figure 6 CISPR Quasi-Peak (QP) limits for 9 kHz – 30 MHz frequency range

considered for 150 kHz - 30 MHz and for 9 - 150 kHz CISPR15 [7] is applied as a generic standard. CISPR 15 is one of the only few existing standards defined for lighting and similar equipment but it is not a general standard. **Figure 6** illustrates the considered standards.

3.1 Modifying EMI Filter

In this paper, as the focus is on the low frequency EMI emissions, only DM EMI filter is considered. As it has been shown in [8], for a multiple-stage LC filter, the minimum volume can be obtained if same inductance and capacitance values are selected for all stages. In this study a two-stage DM filter is considered with one damping stage (**Figure 7**). Following the required standard limit the required attenuation based on the measured emission in (1) can be estimated as [3]:

$$Att_{req}(f_{sweep})[dB] = U_{max}(f_{sweep})[dB\mu V] - CISPR_{Limit}(f_{sweep})[dB\mu V] + Margin[dB] \quad (2)$$

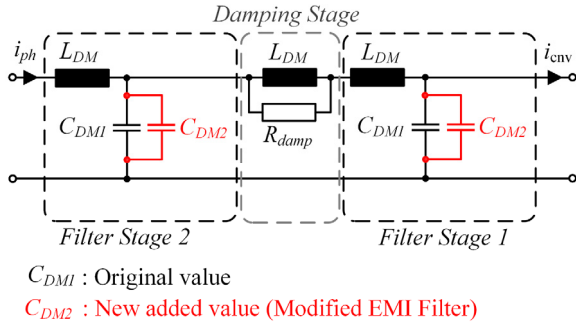

Figure 7 DM EMI filter configuration with two filtering stages and one damping stage

where U_{max} is the first peak emission appeared in the frequency band of interest. In (2) a *Margin* with typical value of 6 dB is accounted for the existed uncertainties due to parameter tolerances. Based on (2) and the two-stage EMI filter attenuation the following should be met:

$$\underbrace{Att_{EMI_Filter}(f_{sweep})}_{\left| \left((j2\pi f_{sweep})^2 L_f C_f + 1 \right)^2 + (j2\pi f_{sweep})^2 L_f C_f \right|} \geq Att_{req}(f_{sweep}) \quad (3)$$

Notably, in (3) the effect of the damping stage is neglected. Based on low-pass filter behavior of an EMI filter, the simplest way to mitigate the emission within the 9 - 150 kHz range is to shift the filter cut-off frequency to a lower value, which in return increase the size of the EMI filter and may lead to stability issues.

Moreover, as it is shown in the result section, modifying the EMI filter (e.g., here by adding another capacitor C_{DM2}) reduces the emissions below the low-frequency limit. The amount of EMI filter size increase depends on the converter switching frequency and L_{dc} .

3.2 Spectral Shaping

One of the effective methods to improve the EMI performance of a converter without significantly changing the EMI filter size is to modify noise emission spectrum. Generally, spreading the noise emission energy across the spectrum can be obtained in two different ways; (a) variable switching frequency and (b) randomization schemes. However, over the past decade these spectral shaping techniques have been mostly applied to DC-DC converters operating at $f_{sw} > 150$ kHz in order to reduce EMI emissions above 150 kHz.

In this paper, in order to mitigate low frequency EMI emissions, frequency dithering technique [9]-[11] as a variable switching frequency scheme is considered for the spectral shaping. The basic concept behind frequency dithering is to change the switching frequency within a specific band rather than having a fixed switching frequency. **Figure 8** shows the frequency dithering concept in a PFC rectifier. The general time-domain analytical expression of a frequency modulated sinusoidal signal following a specific modulation profile $m(\tau)$ is [10]:

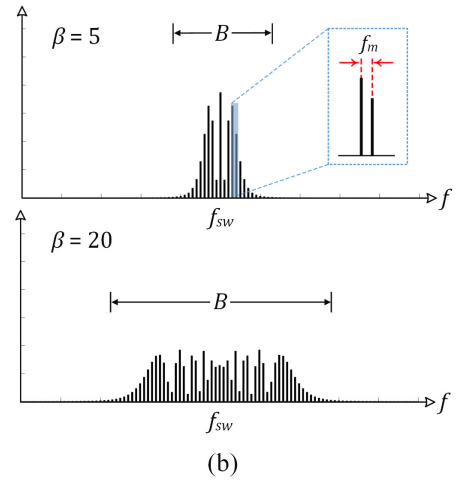
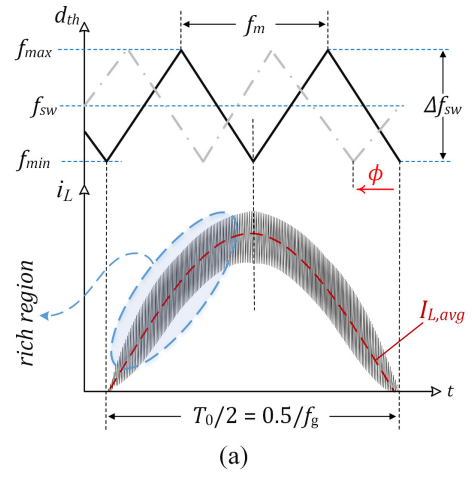

Figure 8 (a) frequency dithering scheme using triangular modulation signal, (b) effects of modulating index β on the spectral content of the modulated signal

$$F(t) = A_c \cos \left(2\pi f_{sw} t + \underbrace{2\pi \int_0^t m(\tau) d\tau}_{\theta(t)} \right) \quad (4)$$

where A_c is the amplitude of carrier signal, f_{sw} is the switching frequency and $\theta(t)$ is a time dependent phase angle. The modulating profile $m(\tau)$ can be sinusoidal, square wave, sawtooth and triangular [9]. As it is shown in **Figure 8(a)**, the triangular profile as one of the most effective approaches is selected for this study. A symmetrical triangular waveform can be expressed in time domain using Fourier series analysis as:

$$m(\tau) = A_m \frac{8}{\pi^2} \sum_{n=1,3,5,\dots}^{\infty} \frac{(-1)^{(n-1)/2}}{n^2} \sin(2\pi n f_m \tau - \phi) \quad (5)$$

with A_m and f_m being the amplitude and the frequency of the modulating waveform, respectively.

$$A_m = \frac{f_{max} - f_{min}}{2} = \frac{\Delta f_{sw}}{2} \quad (6)$$

By taking integral of (5) and substituting in (4), the time dependent phase angle can be given as:

$$\theta(t) = \beta \frac{-8}{\pi^2} \sum_{n=1,3,5,\dots}^{\infty} \frac{(-1)^{(n-1)/2}}{n^3} \cos(2\pi n f_m t - \phi) \quad (7)$$

where β is defined as modulation index:

$$\beta = \frac{\Delta f_{sw} / 2}{f_m} \quad (8)$$

According to [9], [10] the modulating index β directly affects the spread spectrum bandwidth B :

$$B^h = 2(\beta \cdot h + 1) f_m \xrightarrow{\text{if } \beta \gg 1} B = \Delta f_{sw} \quad (9)$$

with h being the multiple of the switching frequency harmonics. As it is exemplified in **Figure 8(b)**, as β increases the signal energy more distributed over the bandwidth. Based on (8) this can be obtained by increasing the frequency deviation or reducing modulating signal frequency. However, from EMI measurement point of view there are three important factors to be considered. Firstly, as it is shown in **Figure 8(b)**, the modulating frequency (f_m) defines the distance between the spread frequency bins. Therefore, it should be selected to be $f_m \geq BW_{RBW}$, which BW_{RBW} is the bandwidth of the EMI receiver RBW filter. Since this filter has a bandwidth of 200 Hz for the 9–150 kHz range, the distance of the frequency bins should be equal or larger than 200 Hz. The second important factor is the spread spectrum bandwidth (i.e., B). This factor should be selected in a way to prevent possible overlaps between the multiple of the switching frequency harmonics, which reduce the effectiveness of the dithering technique. Finally, according to (5) the phase shift of the dithering signal ϕ can affect the energy of the spread spectrum. However, this effect cannot be analyzed using the frequency modulating function [11]. This parameter should be set following the power converter PWM operation. As it is shown in **Figure 8(a)**, the dithering signal is adjusted at the *reach region* where the maximum switching happens.

4 Results

In order to evaluate the proposed solutions, the PFC rectifier shown in **Figure 2** is considered with two different switching frequency (f_{sw}) under Continuous Conduction Mode (CCM) as it is summarized in **Table 1**.

Firstly, in order to show the 9–150 kHz EMI performance of the PFC rectifier when its EMI filter is originally designed to meet > 150 kHz (Band B) limits, two simulation cases are considered. **Figure 9** illustrates the simulated EMI emission of a single-phase PFC converter operating at two different switching frequencies. As it can be seen, the generated emission based on the original EMI filter designed to meet above 150 kHz limits does not comply with CISPR 15 limits. **Table 2** summarizes the differences between C_{DM} values for each considered cases. Notably, increasing the size of the EMI filter not only impair the converter power density, increase cost and loss, but it also may create low frequency resonances at system level [12].

In order to evaluate the simulation results a hardware prototype is implemented following **Table 1** and **2** parameters. **Figure 10** depicts the measured experimental waveforms with frequency dithering operation. Finally, **Figure 11** shows comparative simulation and experimental results. Following the required modified EMI filter values it is obvious that applying the frequency dithering can result in a smaller EMI filter size. Comparing with only increasing the EMI filter capacitance (C_{DM2}), applying frequency dithering in both switching frequency cases result in 1.64 times smaller capacitor size. Thereby, it is an effective method in adapting PFC rectifiers with minimum modifications on the original circuit to meet the new frequency of Band A limits.

Table 1 Parameters of the System

Symbol	Parameter	Value
U_s	Grid phase voltage	230 V _{rms}
f_g	Grid frequency	50 Hz
L_{dc}	DC link inductor	1.8 mH @ $f_{sw} = 20$ kHz 0.9 mH @ $f_{sw} = 40$ kHz
C_{dc}	DC link capacitor	500 μ F
U_{dc}	Output voltage	400 V _{dc}
P_o	Output power	1 kW

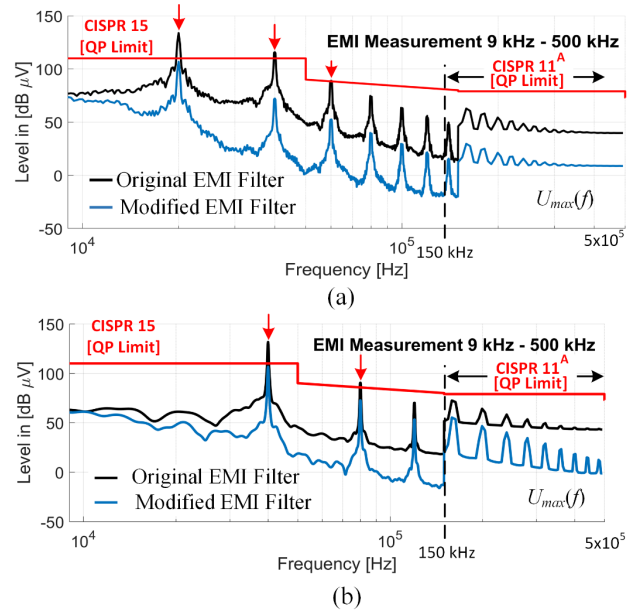

Figure 9 Obtained simulation results with original and modified EMI filter at two different operating conditions of (a) $f_{sw} = 20$ kHz, (b) $f_{sw} = 40$ kHz

Table 2 Modified EMI Filter Values (L_{dm} is fixed @ 180 μ H, $R_{damp} = 11 \Omega$)

f_{sw}	dithering	Δf_{sw}	f_m	* C_{DM1}	** C_{DM2}
20 kHz	No	-	-	250 nF	1.4 μ F
20 kHz	Yes	6 kHz	200 Hz	250 nF	750 nF
40 kHz	No	-	-	250 nF	390 nF
40 kHz	Yes	12 kHz	200 Hz	250 nF	140 nF

* C_{DM1} : Original value to meet > 150 kHz standard limit

** C_{DM2} : New value added to meet 9–150 kHz limit (see **Figure 7**)

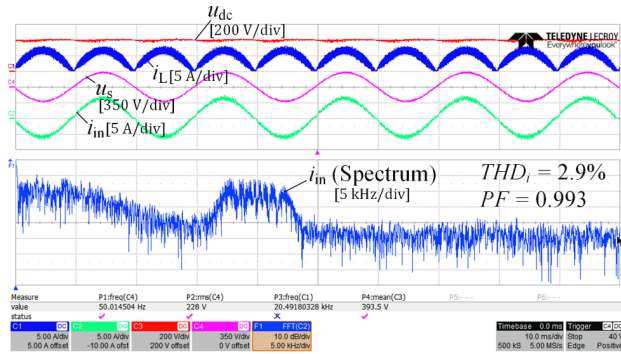

Figure 10 Measured experimental waveform of a single-phase PFC rectifier with **Table 1** and **2** parameters ($f_{sw} = 20$ kHz and modified EMI filter) with frequency dithering

Moreover, the obtained results not only confirms the effectiveness of the investigated methods, but also shows a close agreement between the obtained simulation results using the employed frequency-domain approach and the measured results. It is to be noted that since using frequency dithering results in a spread spectrum, further investigation regarding obtaining proper EMI filter damping is required.

5 Conclusion

This paper investigates feasible approaches in mitigating EMI emission within the new 9-150 kHz frequency range. Although, increasing the size of EMI filter would be an easy solution, but it is not a feasible approach since it increases the size, cost and loss of the system. The EMI filter modification could be kept as minimum as possible if spectral shaping method is utilized. The presented simulation and experimental results validated the proposed strategies.

6 Literature

- [1] D. Heirman, "EMC Standards Activity," *IEEE Electromagn. Compat. Mag.*, vol. 3, no. 1, pp. 96-99, 1st Quarter 2014.
- [2] F. Zare, H. Soltani, D. Kumar, P. Davari, H. A. M. Delpino and F. Blaabjerg, "Harmonic Emissions of Three-Phase Diode Rectifiers in Distribution Networks," *IEEE Access*, vol. 5, pp. 2819-2833, 2017.
- [3] T. Nussbaumer, K. Raggl and J. W. Kolar, "Design Guidelines for Interleaved Single-Phase Boost PFC Circuits," *IEEE Trans. Ind. Electron.*, vol. 56, no. 7, pp. 2559-2573, July 2009.
- [4] T. Nussbaumer, M. L. Heldwein and J. W. Kolar, "Differential Mode Input Filter Design for a Three-Phase Buck-Type PWM Rectifier Based on Modeling of the EMC Test Receiver," *IEEE Trans. Ind. Electron.*, vol. 53, no. 5, pp. 1649-1661, Oct 2006.
- [5] C.I.S.P.R., *Specification for Radio Interference Measuring Apparatus and Measurement Methods-Publication 16*, 2015, IEC Int. Special Committee on Radio Interference.
- [6] C.I.S.P.R., *Limits and methods of measurement of radio disturbance characteristics of Industrial, scientific and medical equipment-Publication 11*, 2010, IEC Int. Special Committee on Radio Interference.

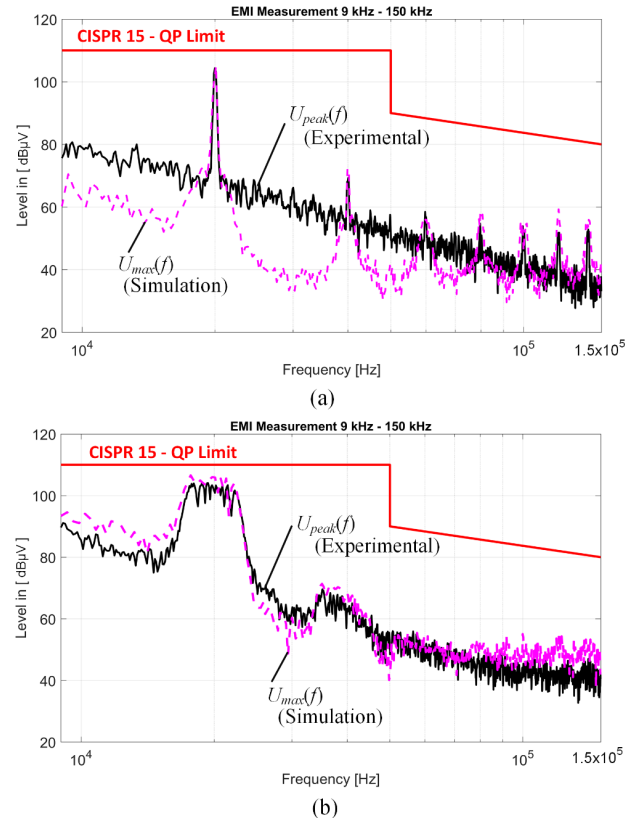

Figure 11 Obtained experimental and simulation EMI peak measurement (Band A): (a) modified EMI filter with fixed switching frequency of 20 kHz, (b) modified EMI filter with frequency dithering ($f_{sw} = 20$ kHz, $\Delta f_{sw} = 6$ kHz)

- [7] C.I.S.P.R., *Limits and methods of measurement of radio disturbance characteristics of electrical lighting and similar equipment-Publication 15*, 2015, IEC Int. Special Committee on Radio Interference.
- [8] M. L. Heldwein and J. W. Kolar, "Design of minimum volume EMC input filters for an ultra compact three-phase PWM rectifier," in *Proc. COBEP'07*, 2007.
- [9] S. Johnson and R. Zane, "Custom spectral shaping for EMI reduction in high-frequency inverters and ballasts," in *IEEE Trans. Power Electron.*, vol. 20, no. 6, pp. 1499-1505, Nov. 2005.
- [10] J. Balcells, A. Santolaria, A. Orlandi, D. Gonzalez and J. Gago, "EMI reduction in switched power converters using frequency Modulation techniques," in *IEEE Trans. Electromagn. Compat.*, vol. 47, no. 3, pp. 569-576, Aug. 2005.
- [11] A. Elrayyah, K. MPK Namburi, Y. Sozer and I. Husain, "An Effective Dithering Method for Electromagnetic Interference (EMI) Reduction in Single-Phase DC/AC Inverters," in *IEEE Trans. Power Electron.*, vol. 29, no. 6, pp. 2798-2806, June 2014.
- [12] P. Kotsampopoulos *et al.*, "EMC Issues in the Interaction Between Smart Meters and Power-Electronic Interfaces," in *IEEE Trans. Power Del.*, vol. 32, no. 2, pp. 822-831, April 2017.