



Aalborg Universitet

AALBORG UNIVERSITY
DENMARK

A Power Sharing Method Based on Modified Droop Control for Modular UPS

Wei, Baoze; Liu, Wenzhao; Guerrero, Josep M.; Quintero, Juan Carlos Vasquez

Published in:

Proceedings of 43rd Annual Conference of the IEEE Industrial Electronics Society, IECON 2017

DOI (link to publication from Publisher):

[10.1109/IECON.2017.8216835](https://doi.org/10.1109/IECON.2017.8216835)

Publication date:

2017

Document Version

Accepted author manuscript, peer reviewed version

[Link to publication from Aalborg University](#)

Citation for published version (APA):

Wei, B., Liu, W., Guerrero, J. M., & Quintero, J. C. V. (2017). A Power Sharing Method Based on Modified Droop Control for Modular UPS. In *Proceedings of 43rd Annual Conference of the IEEE Industrial Electronics Society, IECON 2017* (pp. 4839-4844). IEEE Press. Proceedings of the Annual Conference of the IEEE Industrial Electronics Society <https://doi.org/10.1109/IECON.2017.8216835>

General rights

Copyright and moral rights for the publications made accessible in the public portal are retained by the authors and/or other copyright owners and it is a condition of accessing publications that users recognise and abide by the legal requirements associated with these rights.

- ? Users may download and print one copy of any publication from the public portal for the purpose of private study or research.
- ? You may not further distribute the material or use it for any profit-making activity or commercial gain
- ? You may freely distribute the URL identifying the publication in the public portal ?

Take down policy

If you believe that this document breaches copyright please contact us at vbn@aub.aau.dk providing details, and we will remove access to the work immediately and investigate your claim.

A Power Sharing Method Based on Modified Droop Control for Modular UPS

Baoze Wei, Wenzhao Liu, Josep M. Guerrero, Juan C. Vásquez

Department of Energy Technology

Aalborg University

Aalborg, Denmark

bao@et.aau.dk, wzl@et.aau.dk, joz@et.aau.dk, juq@et.aau.dk

Abstract— An average power sharing control strategy for parallel operation of voltage source inverter (VSI) based modular Uninterruptible Power Systems (UPSs) is proposed in this paper. The presented method is based on a modified droop control. The proposed method conquers the drawback of conventional droop plus virtual impedance control, and at the same time some challenges in the real applications have been considered. Such as the mismatch of output impedance of the parallel modules, the different calibration accuracy of the sample circuit, and the offset of the voltage reference from the control unit. Simulation has been presented in order to verify the effectiveness of the proposed control methodology under these three different conditions. The simulation results demonstrate that a better power sharing performance is obtained and successfully prevent of negative power which can protect the DC bus.

Keywords—droop control; virtual impedance; modular uninterruptible power system; power sharing; circulating current.

I. INTRODUCTION

Voltage source inverters (VSIs) are widely used in industrial applications [1-4], which is commonly adopted for the Uninterruptible Power Systems (UPSs). UPS is always applied as a reliable power provider, especially for the critical loads, such as distributed generation (DG) systems, high power electric drives, high speed elevators, and data base center that cannot afford power loss [5].

The modular design concept of UPS appeared at later 1990s [5]. The basic idea is that in a modular UPS, it contains two or more converter modules working in parallel to feed power to the loads. The modular concept has some advantages, such as increasing the power capacity regardless the rating limited of switching devices, increasing the flexibility, reliability and maintainability of power supply systems to meet the requirements of customers. And some redundant power modules can be put in a modular UPS to ensure high availability: When one power module fails, another one can be able to continue supplying power to loads [6].

As mentioned above, in a modular UPS, the converter modules work in parallel with each other, one of the important issue that should be considered is the average power sharing [7]. Worse power sharing performance will lead to serious circulating current problem and cause different current stress on the switching devices. And in some worse cases, if the

circulating current is big enough, it will lead to negative current to threaten the safety of DC bus and significantly decrease the lifetime of higher power output modules. So average power sharing is an important issue to be considered in a modular UPS.

A traditional current-sharing solution is the frequency and voltage droop method [8], [9]. As one of the decentralized control methods, droop control is suitable for modular design of the UPS. The main idea of the droop control is to regulate the voltage and the frequency by regulating the reactive and the active power respectively which can be sensed locally. The droop control method has many desirable features such as expandability, modularity, redundancy, and flexibility.

But the droop-method performance is particularly sensitive to the output impedance of the parallel inverters [8]. Virtual impedance is proposed in [9] to modify the output impedance, contributing to good power-sharing accuracy. However, in a practical paralleled inverters system, it is difficult to design proper virtual impedance [10]. And if poorly designed or implemented, the virtual impedance may introduce current distortions and adversely affect the system stability and dynamics [11]. And in the real applications, like the modular UPS, even it is the same model, the converter modules cannot be exactly the same, such as the output impedance, the accuracy of the voltage and current sample circuit, that is why that a calibration of the units is necessary before working in parallel. The calibration work is mainly to make sure that the voltage and current sample circuits have the same accuracy, feedback a same value for a common voltage or current. But a perfect calibration cannot be guaranty since the working environment or the line impedance may change. There is another case should be considered. Now almost all the UPS are controlled by digital signal processors (DSP), since the control boards are independent among the parallel units, maybe there is offset between the settings or control parameters in the control boards. As a perfect calibration cannot be guaranty, the offset of the settings in the digital control board should also be considered. For a voltage controlled inverter, the voltage reference is one of the important parameter in the control.

So in this paper, 3 main cases are considered to simulate the real UPS hardware.

1) The unmatched set of virtual impedance to simulate the different output impedance of different modules.

2) A worse calibration of voltage sample circuits.

3) The unmatched set of voltage reference to imitate the inner offset of the digital controller (DSP).

In order to solve the problems of above mentioned control strategies, this paper presents a control strategy based on the modified droop control. Compared with the conventional droop control, the average power among the parallel modules has been used to modify the droop function, by this modification, the droop control can adjust the voltage quickly based on the difference between the output power of local module and the average power of the parallel modules. And simulation has been done considering the 3 cases mentioned above. And the modular UPS was built with three-level neutral point clamped (NPC) inverter, the topology is shown in Fig.1. Compared with the conventional droop, a better average power sharing performance is obtained with the modified droop control.

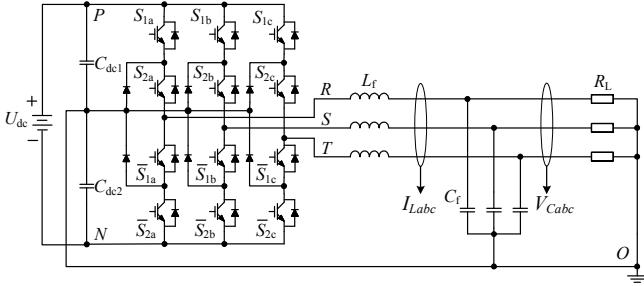

Fig. 1. Topology of the NPC inverter.

This paper is organized as follows: In Section II, the concept of the traditional droop control is briefly introduced firstly, then the idea of the modified droop control is given and the circulating current analysis for paralleled current source inverters is discussed. In Section III, simulation results are implemented which verify the effectiveness of the presented idea. The conclusions are given in Section IV.

II. THE PROPOSED CONTROL STRATEGY

A. The concept of the traditional droop control

The output impedance of the closed-loop inverter determines the droop control strategy [10]. The conventional droop scheme $P - \omega$ and $Q - V$ is often adopted. With the droop control, the frequency and the amplitude of the inverter output-voltage reference can be expressed as [14]:

$$\omega = \omega^* - m_p P \quad (1)$$

$$E = E^* - m_q Q \quad (2)$$

where ω^* and E^* are the output voltage reference frequency and amplitude, m_p and m_q are the droop coefficients [12], [13]. And for the conventional droop control scheme, a highly inductive output impedance at fundamental frequency is required to decouple the influence of P and Q to the frequency and voltage amplitude [13].

But based on the filter topology used in this paper and chosen of the control parameters and the virtual resistance, the output impedance is more resistive. So the droop function will be modified as:

$$\omega = \omega^* + m_q Q \quad (3)$$

$$E = E^* - m_p P \quad (4)$$

The active power can be controlled by the inverter output-voltage amplitude while the reactive power can be regulated by the inverter frequency, which is the opposite strategy of the conventional droop method. More details about the chosen of droop function and the analysis of output impedance can be found in [12], [13], [15].

B. The proposed modified droop control loop

In this paper, in order to have a better power sharing performance among the parallel modules in a modular UPS under different conditions, the 3 cases mentioned above, to increase the stability of the system, a very simple modification has been done to the P/V droop function.

The modified droop control is shown in (5) and (6), in which P_{av} and Q_{av} are the average active power and reactive power of the parallel modules respectively, P and Q are the active power and reactive power of the local module. With this modification, the difference between the active and reactive power of the local module and the average active and reactive power of parallel modules are considered in the control, so a faster and better power sharing can be obtained among the parallel modules.

The functions are simple, but there is still something to be noticed. As we know, one of the reason of unbalanced active power sharing is the unbalanced output voltage, higher voltage lead to higher output current. Through the function (5), one can notice that, if the active power P of the local module is lower than the average active power, with the additional part of the modified the droop function, the conventional droop function will be added a positive value to increase the output voltage which lead to a higher output current. So with proper control parameters, a better active power sharing performance can be obtained. And for the 3 different cases mentioned above, all of them will lead to unmatched output voltage, such as the reason of different voltage drop on the virtual impedance, the unmatched of voltage sample circuit, the different setting of voltage reference because of the offset of the digital controllers. And with function (6), the frequency (angel) of the output voltage can be adjusted by the average and local reactive power, which can guarantee a better reactive power sharing and at the same time a better synchronization performance is obtained.

$$E = E^* - m_p P + m_p' (P_{av} - P) \quad (5)$$

$$\omega = \omega^* + m_q Q + m_q' (Q_{av} - Q) \quad (6)$$

C. Analysis of the circulating current

This paper takes a UPS system contains 3 inverter modules for an example to verify the effectiveness of the proposed method. According to literature [13], the circulating current I_{cir} can be defined as:

$$I_{cir} = (I_1 - I_2) / 2 \quad (7)$$

where I_1 and I_2 are the output currents of different modules.

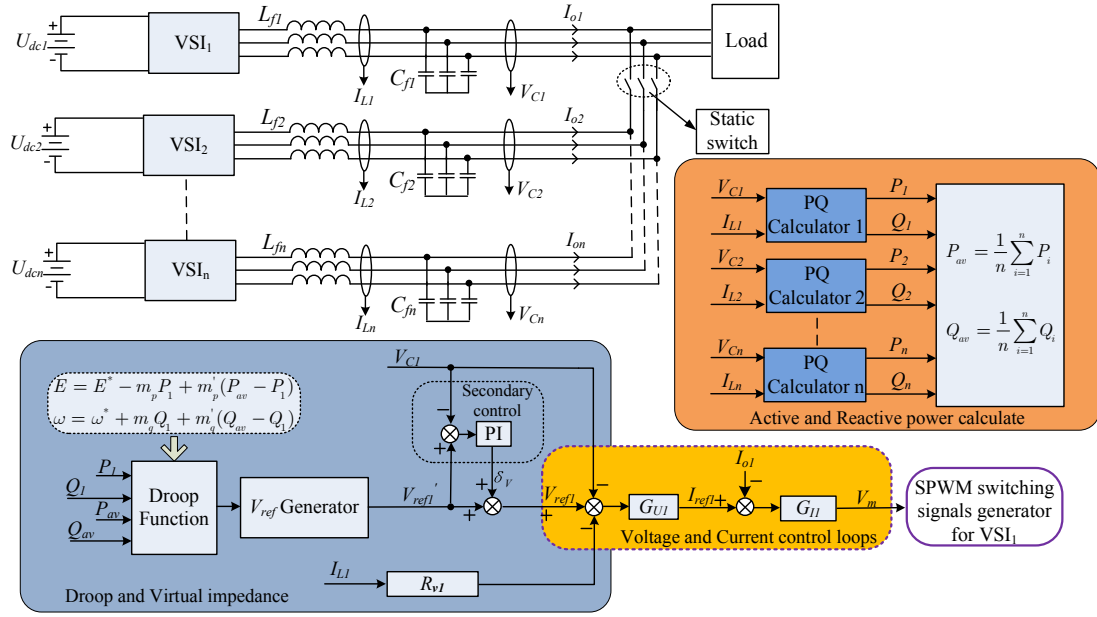

Fig. 2. The block diagram of the control structure with the modified droop control.

Assuming that the output impedances of the parallel inverters are equal to each other, $Z_1=Z_2=Z$, then the circulating current can be calculated as:

$$I_{cir} = (E_1 - E_2) / 2Z \quad (8)$$

III. SIMULATION RESULTS

In order to verify the effectiveness of the proposed control strategy, a UPS model consists of three inverter modules was built in PLECS, using the modified droop control method. Three different cases were considered in the simulation to imitate the circumstances of the real hardware platform. The parameters of the simulated modular UPS platform are shown in Table I.

It should be noticed that a dynamic test is set in the simulation to verify the reliability of the control. At the very beginning, three modules were working, at time 0.08s, one of the modules was powered off, and at the time 0.15s, it was restart to feed power to the load.

TABLE I
PARAMETERS SETTING OF DIFFERENT CASES

	Case 1	Case 2	Case 3
	Virtual impedance	Calibration parameter of voltage	Voltage Reference
Module 1	0.3 Ω	1.0	230*1.01V(RMS)
Module 2	0.2 Ω	0.9	230V(RMS)
Module 3	0.4 Ω	1.1	230*0.99V(RMS)

3.1 Test with all the same parameters of three cases.

Fig.3 to Fig.5 were shown the simulation results under ideal condition with all the same parameters of three modules. From the results, one can notice that with the proposed control, an average active and reactive power sharing performance was obtained under dynamic test which verified the effectiveness of the proposed control method.

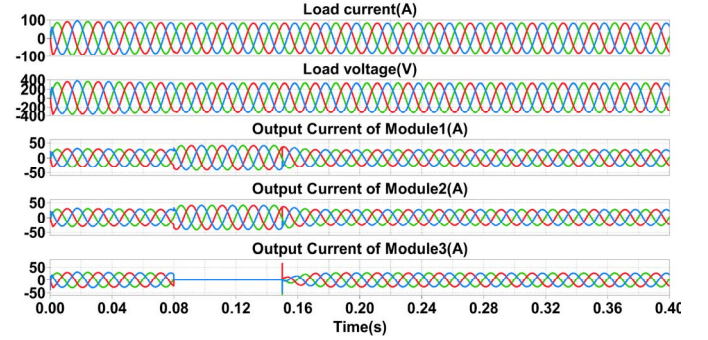

Fig. 3. Simulation results of the modular UPS under same parameters.

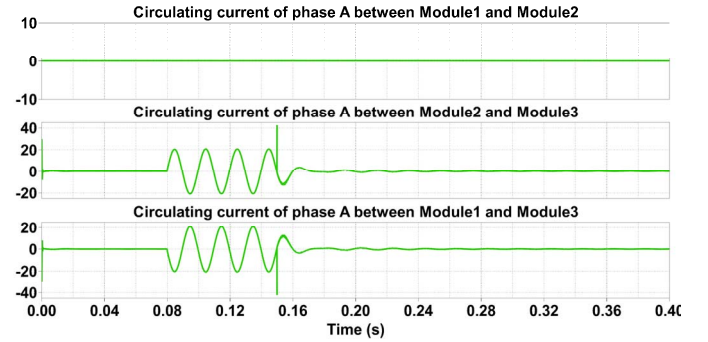

Fig. 4. Circulating currents among three modules under same parameters.

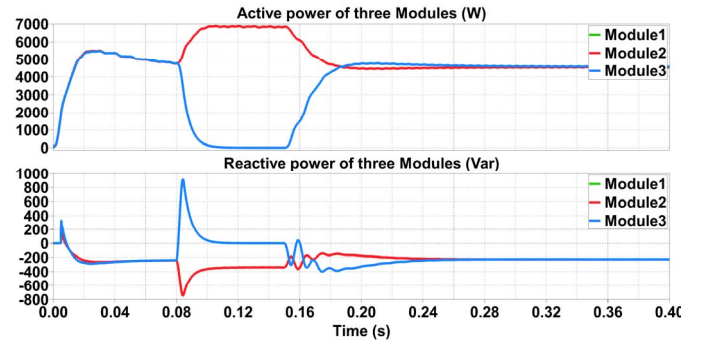

Fig. 5. Output power of three modules under same parameters.

3.2 Simulation results of Case1.

The case1 simulation is to imitate the different output impedances of the real hardware modules. One can notice that, compared with the conventional droop control, a much better power sharing performance was obtained with the proposed control method.

3.2.1 Simulation with conventional control method.

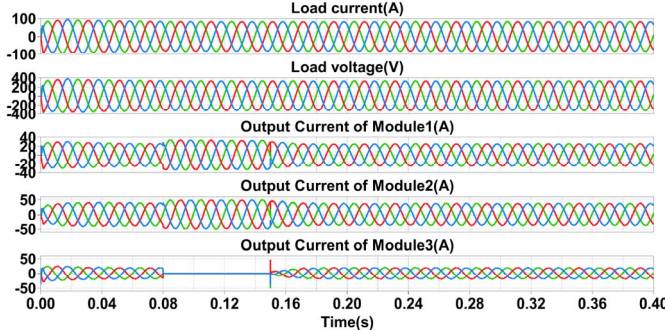

Fig. 6. Simulation results under case1 with the conventional control.

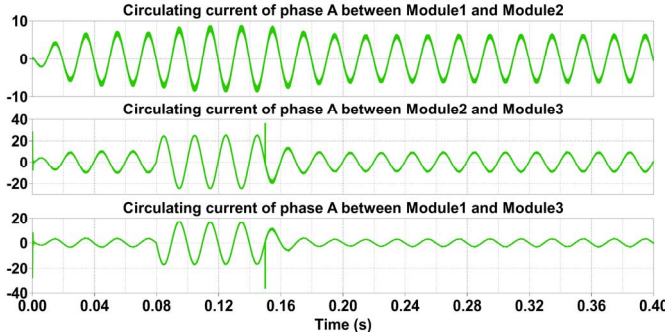

Fig. 7. Circulating currents among three modules under case1 with conventional control.

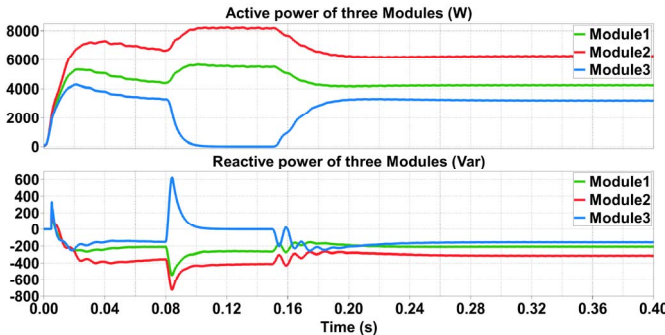

Fig. 8. Output power of three modules under case1 with conventional control.

3.2.2 Simulation with proposed control method.

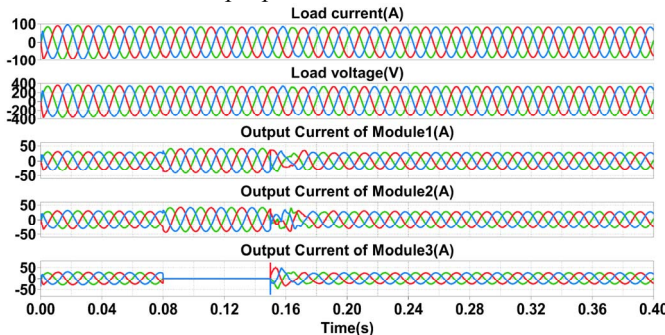

Fig. 9. Simulation results under case1 with the proposed control.

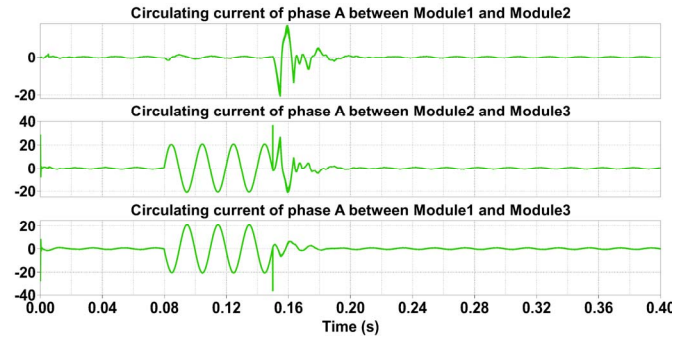

Fig. 10. Circulating currents among three modules under case1 with proposed control.

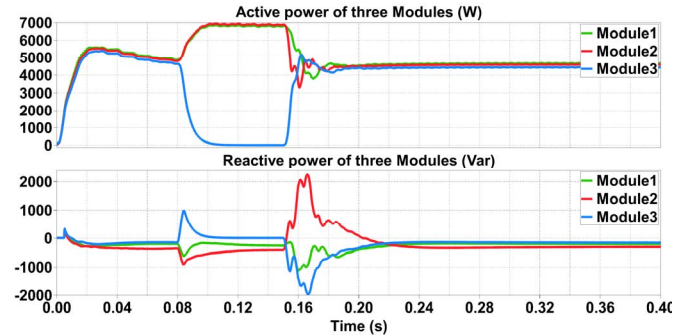

Fig. 11. Output power of three modules under case1 with proposed control.

3.3 Simulation results of Case2.

In order to simulate the sample circuit of the real UPS platform, in this section, a worse voltage calibration circumstance is set with different voltage calibration parameters. Up to 20% difference of voltage sample as shown in Table I. Actually this a huge difference which will lead to a very different output power. As mentioned in some datasheets of the industrial products, the calibration will be optimized within 1% for different modules.

From the simulation results, one can notice that, with the conventional droop control, one of the three modules absorbed active power from the other two modules which will threaten the safety of the DC bus of this module, and the output active power of the three modules was totally different. And there was big current distortion. And also, one can notice that, a much better average power sharing performance and sinewave output currents were obtained in the working modules with the proposed control method.

3.3.1 Simulation with conventional control method.

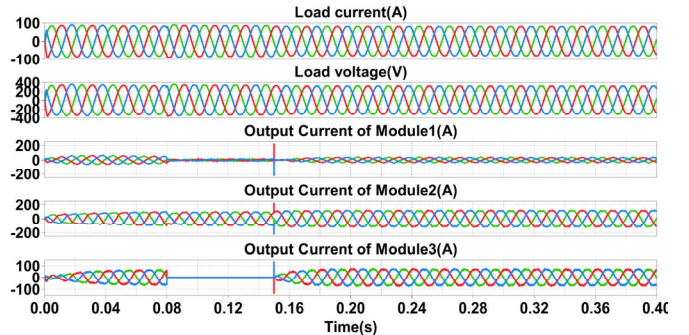

Fig. 12. Simulation results under case2 with the conventional control.

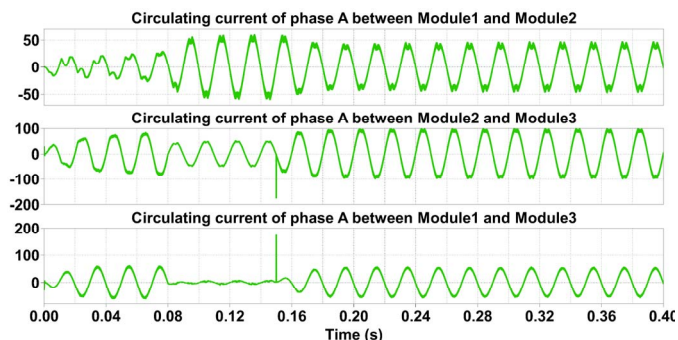

Fig. 13. Circulating currents among three modules under case2 with conventional control.

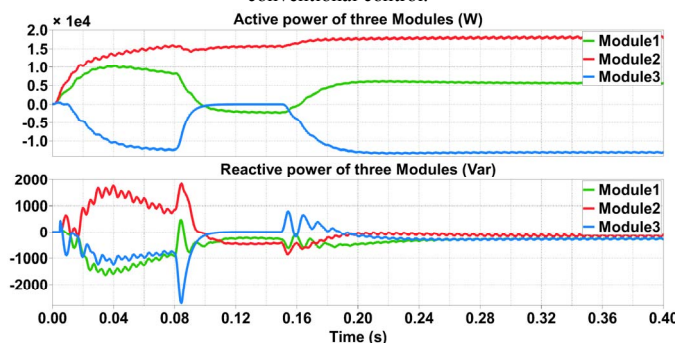

Fig. 14. Output power of three modules under case2 with conventional control.

3.3.2 Simulation with proposed control method.

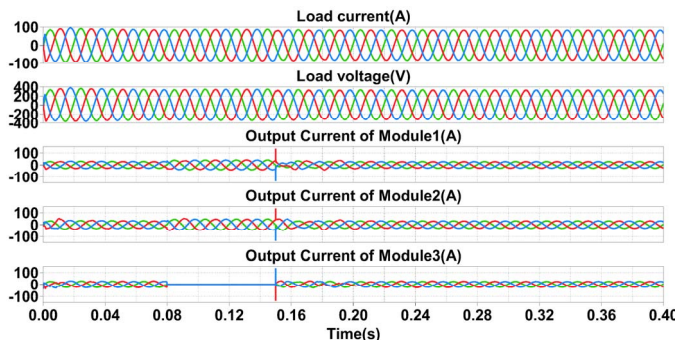

Fig. 15. Simulation results under case2 with the proposed control.

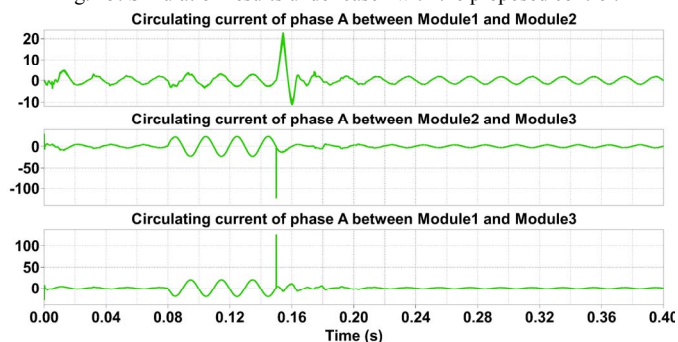

Fig. 16. Circulating currents among three modules under case2 with proposed control.

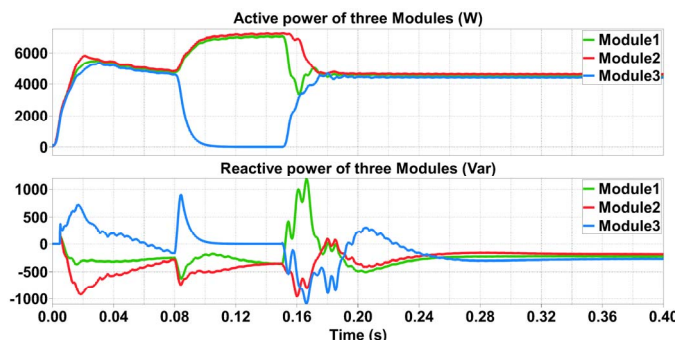

Fig. 17. Output power of three modules under case2 with proposed control.

3.4 Simulation results of Case3.

In case3, three different voltage references were set in the simulation to imitate the offset of the digital signal processor (DSP), the different ratio is up to 2% as shown in Table I. The simulation results were also verified the effectiveness of the proposed control method; an average power sharing performance was obtained.

3.4.1 Simulation with conventional control method:

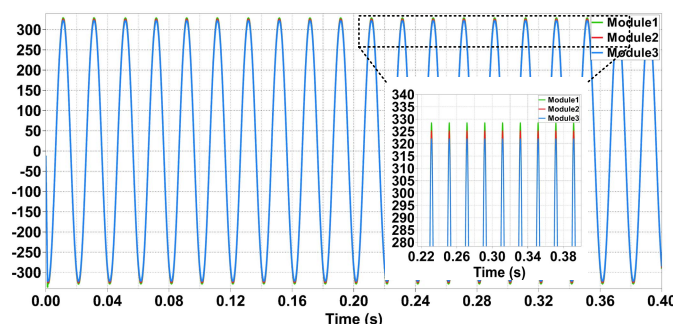

Fig. 18. The reference voltages of three modules under case3.

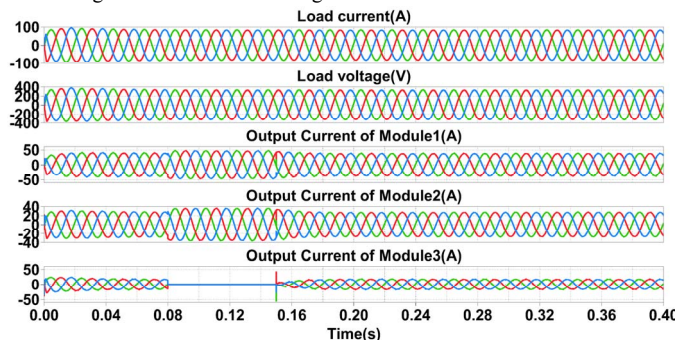

Fig. 19. Simulation results under case3 with the conventional control.

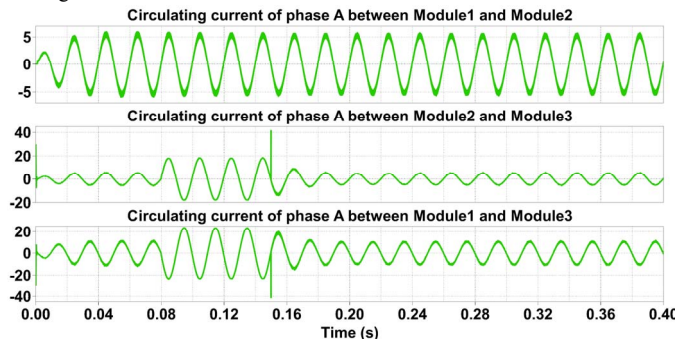

Fig. 20. Circulating currents among three modules under case3 with conventional control.

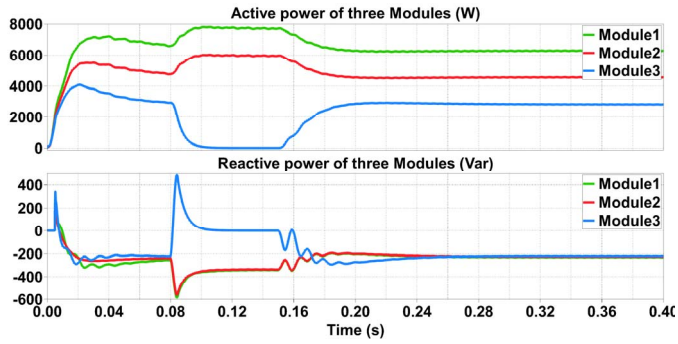

Fig. 21. Output power of three modules under case3 with conventional control.

3.4.2 Simulation with proposed control method.

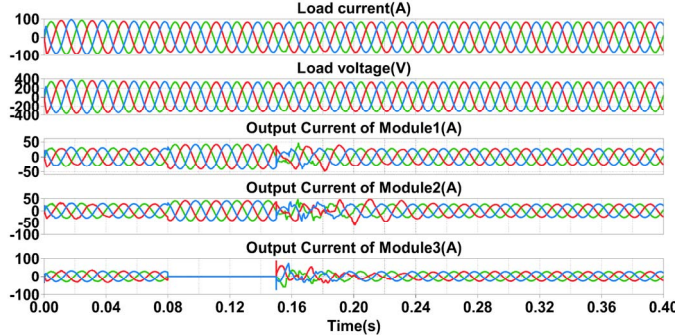

Fig. 22. Simulation results under case3 with the proposed control.

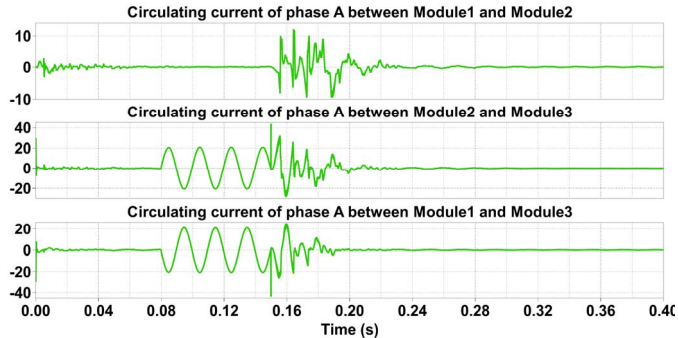

Fig. 23. Circulating currents among three modules under case3 with proposed control.

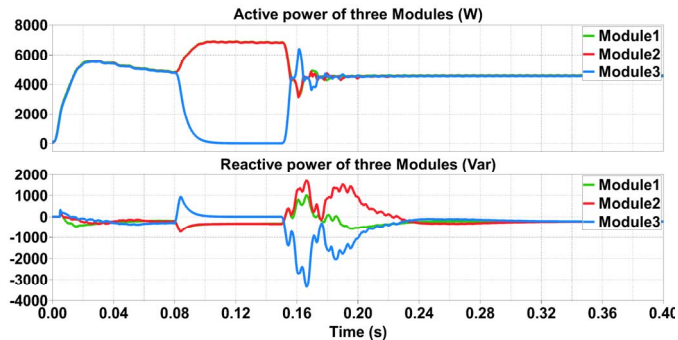

Fig. 24. Output power of three modules under case3 with proposed control.

IV. CONCLUSION

Modular UPS is more and more attractive in industrial applications for higher reliability demand, and the average power-sharing performance is necessary. A modified droop control method was proposed in this paper for the control of

modular UPS. A simulated UPS containing three inverter modules was designed with the simulation software PLECS. And three different cases were set to imitate the real platform to verify the stability of the proposed control. The simulation results demonstrate that, compared to the conventional droop control, the circulating current among the parallel modules can be effectively suppressed under different cases, and a better average power sharing is obtained with the modified droop control. More analysis and test will be done in the future work with the real UPS platform.

REFERENCES

- [1] X. Guo, W. Liu, and Z. Lu, "Flexible power regulation and current-limited control of grid-connected inverter under unbalanced grid voltage faults," *IEEE Trans. Ind. Electron.*, vol. 64, no. 9, pp. 7425-7432, Sept. 2017.
- [2] X. Guo, "Three phase CH7 inverter with a new space vector modulation to reduce leakage current for transformerless photovoltaic systems," *IEEE Journal of Emerging and Selected Topics in Power Electronics*, vol. 5, no. 2, pp. 708-712, 2017.
- [3] X. Guo, "A novel CH5 inverter for single-phase transformerless photovoltaic system applications," *IEEE Trans. Circuits and Systems II: Express Briefs*, DOI: 10.1109/TCSII.2017.2672779.
- [4] X. Guo, B. We, T. Zhu, Z. Lu, L. Tan, X. Sun, and C. Zhang, "Leakage current suppression of three phase flying capacitor PV inverter with new carrier modulation and logic function," *IEEE Trans. Power Electron.*, DOI: 10.1109/TPEL.2017.2692753.
- [5] X. Zhang, Z. Wang, and S. Zhou, "How to ensure the modular UPS with high reliability," in *Proc. IEEE INTELEC 2015*, Oct. 18-22, pp. 1 - 4.
- [6] L. Saro, and C. Zanettin, "The impact of a single module's MTBF value in modular UPS systems: Technique for its assessment, improvement and final validation," in *Proc. IEEE INTELEC 2016*, Oct. 23-27, pp. 1 - 8.
- [7] T. B. Lazzarin, G. A. T. Bauer, and I. Barbi, "A control strategy for parallel operation of single-phase voltage source inverters: Analysis, design and experimental result," *IEEE Trans. Ind. Electron.*, vol. 60, no. 6, pp. 2194-2204, Jun. 2013.
- [8] Y. Zhang, M. Yu, F. Liu, and Y. Kang, "Instantaneous Current-Sharing Control Strategy for Parallel Operation of UPS Modules Using Virtual Impedance," *IEEE Trans. Power Electron.*, vol. 28, no. 1, pp. 432-440, Jan. 2013.
- [9] J. M. Guerrero, L. G. Vicuna, J. Matas, M. Castilla, and J. Miret, "Output impedance design of parallel-connected UPS inverters with wireless load-sharing control," *IEEE Trans. Ind. Electron.*, vol. 52, no. 4, pp. 1126-1135, Aug. 2005.
- [10] H. Shi, F. Zhuo, D. Zhang, Z. Geng, and F. Wang, "Adaptive Implementation Strategy of Virtual Impedance for Paralleled Inverters UPS," in *Proc. IEEE ECCE 2014*, Sep. 14-18, pp. 158-162.
- [11] J. He, and Y. Li, "Analysis, Design, and Implementation of Virtual Impedance for Power Electronics Interfaced Distributed Generation," *IEEE Trans. Ind. Applica.*, vol. 47, no. 6, pp. 2525-2538, Nov. 2011.
- [12] E. A. Coelho, D. Wu, J. M. Guerrero, J. C. Vasquez, T. Dragičević, Č. Stefanović, and P. Popovski, "Small-Signal Analysis of the Microgrid Secondary Control Considering a Communication Time Delay," *IEEE Trans. Ind. Electron.*, vol. 63, no. 10, pp. 6257-6269, Oct. 2016.
- [13] J. Matas, M. Castilla, L. Vicuña, J. Miret, and J. C. Vasquez, "Virtual Impedance Loop for Droop-Controlled Single-Phase Parallel Inverters Using a Second-Order General-Integrator Scheme," *IEEE Trans. Power Electron.*, vol. 25, no. 12, pp. 2993-3001, Dec. 2010.
- [14] J. M. Guerrero, J. C. Vasquez, L. G. Vicuña, and M. Castilla, "Hierarchical Control of Droop-Controlled AC and DC Microgrids—A General Approach Toward Standardization," *IEEE Trans. Ind. Electron.*, vol. 58, no. 1, pp. 158-172, Jan. 2011.
- [15] S. Xu and J. Xu, "Parallel Control Strategy of Single-Phase Inverter Based on Virtual Impedance," in *Proc. International Conference on Communications, Circuits and Systems (ICCCAS)*, 2010, pp. 589-592.