



---

# **Improvement of Base and Soil Construction Quality by Using Intelligent Compaction Technology: Final Report**

**Technical Report 5-6740-01-1**  
Cooperative Research Program

---

CENTER FOR TRANSPORTATION INFRASTRUCTURE SYSTEMS  
THE UNIVERSITY OF TEXAS AT EL PASO  
EL PASO, TX 79968  
[HTTP://CTIS.UTEP.EDU](http://ctis.utep.edu)

in cooperation with the  
Federal Highway Administration and the  
Texas Department of Transportation



## TECHNICAL REPORT STANDARD TITLE PAGE

|   |   |  |           |
|---|---|--|-----------|
| 1. Report No.<br><b>FHWA/TX-17/5-6740-01-1</b>  | 2. Government Accession No.                                 | 3. Recipient's Catalog No.   |           |
| 4. Title and Subtitle<br><b>Improvement of Base and Soil Construction Quality by Using Intelligent Compaction Technology: Final Report</b>  |   | 5. Report Date<br><b>August 2017; Published November 2017</b>  |           |
|   |   | 6. Performing Organization Code  |           |
| 7. Author(s)<br><b>L. Lemus, J. Beltran, M. Mazari, C. Tirado, R. Aldouri, and S. Nazarian</b>  |   | 8. Performing Organization Report No.<br><b>TX 5-6740-01-1</b>   |           |
| 9. Performing Organization Name and Address<br><b>Center for Transportation Infrastructure Systems<br/>The University of Texas at El Paso<br/>El Paso, Texas 79968-0516</b>   |   | 10. Work Unit No.  |           |
|   |   | 11. Contract or Grant No.<br><b>Project No. 5-6740-01</b>  |           |
| 12. Sponsoring Agency Name and Address<br><b>Texas Department of Transportation<br/>Research and Technology Implementation Division<br/>P.O. Box 5080<br/>Austin, Texas 78763-5080</b>  |   | 13. Type of Report and Period Covered<br><b>Technical Report<br/>Jan. 1, 2015 – Aug. 31, 2017</b>  |           |
|   |   | 14. Sponsoring Agency Code   |           |
| 15. Supplementary Notes<br><b>Project performed in cooperation with Texas Department of Transportation and the Federal Highway Administration.<br/>Research Study Title: Implementation of Intelligent Compaction Technology for Improving Compaction Quality of Soil and Base in Texas</b>   |   |  |           |
| 16. Abstract<br><b>Intelligent Compaction (IC) technique is a fast-developing technology for base and soil compaction quality control. Proof-rolling subgrades and bases using IC rollers upon completion of compaction can identify the less stiff spots and significantly improve the compaction uniformity of the compacted layers. The main objective of this project was to capitalize on the new specification for implementation of IC technology developed through TxDOT research project 0-6740. The specific objectives of this project included: (1) developing and deploying a training program for the TxDOT engineers and inspectors, (2) supporting the districts in implementing the IC technology in their districts, (3) implementing a field monitoring program to quantify the benefits of the IC technology, and (4) assisting TxDOT Construction Division in evaluating and adopting the new IC specification. The activities to achieve these objectives, the lessons learned from the pilot implementation projects, and the conclusions are included in this report.</b> |   |  |           |
| 17. Key Words<br><b>Intelligent Compaction, Geomaterial, Modulus, Stiffness</b>   |   | 18. Distribution Statement<br><b>No restrictions. This document is available to the public through the National Technical service, 5285 Port Royal Road, Springfield, Virginia 22161, <a href="http://www.ntis.gov">www.ntis.gov</a></b> |           |
| 19. Security Classif. (of this report)<br><b>Unclassified</b>   | 20. Security Classif. (of this page)<br><b>Unclassified</b> | 21. No. of Pages<br><b>80</b>  | 22. Price |



# Implementation of Intelligent Compaction Technology for Improving Compaction Quality of Soil and Base in Texas: Final Report

Luis Lemus, BSCE  
Jorge Beltran, MSCE  
Mehran Mazari, PhD  
Cesar Tirado, PhD  
Raed Aldouri, PhD  
Soheil Nazarian, PhD, PE

Research Project 5-6740-01

Conducted for  
Texas Department of Transportation

Final Report

August 2017

Center for Transportation Infrastructure Systems  
The University of Texas at El Paso  
El Paso, TX 79968-0516



## **DISCLAIMERS**

The contents of this report reflect the view of the authors who are responsible for the facts and the accuracy of the data presented herein. The contents do not necessarily reflect the official views or policies of the Texas Department of Transportation or the Federal Highway Administration. This report does not constitute a standard, a specification or a regulation.

The material contained in this report is experimental in nature and is published for informational purposes only. Any discrepancies with official views or policies of the Texas Department of Transportation or the Federal Highway Administration should be discussed with the appropriate Austin Division prior to implementation of the procedures or results.

## **NOT INTENDED FOR CONSTRUCTION, BIDDING, OR PERMIT PURPOSES**

Luis Lemus, BSCE  
Jorge Beltran, MSCE  
Mehran Mazari, PhD  
Cesar Tirado, PhD  
Raed Aldouri, PhD  
Soheil Nazarian, PhD, PE

## **Acknowledgements**

The authors would like to express their sincere appreciation to the Project Management Committee consisting of Jimmy Si and Richard Izzo for their support.

We are grateful to a number of employees of TxDOT, especially Jaime Aparicio, Lawrence (Larry) D. Cannon and Richard Williammee of Fort Worth District, Wade Blackmon of Paris District, and Ruben Carrasco of CST, for their assistance in field testing.

The help from a number of construction companies to accommodate us is also acknowledged.

We are also grateful to a number of undergraduate and graduate students from UTEP for their assistance in the project.

## **Abstract**

Intelligent Compaction (IC) technique is a fast-developing technology for base and soil compaction quality control. Proof-rolling subgrades and bases using IC rollers upon completion of compaction can identify the less stiff spots and significantly improve the compaction uniformity of the compacted layers. The main objective of this project was to capitalize on the new specification for implementation of IC technology developed through TxDOT research project 0-6740. The specific objectives of this project included: (1) developing and deploying a training program for the TxDOT engineers and inspectors, (2) supporting the districts in implementing the IC technology in their districts, (3) implementing a field monitoring program to quantify the benefits of the IC technology, and (4) assisting TxDOT Construction Division in evaluating and adopting the new IC specification. The activities to achieve these objectives, the lessons learned from the pilot implementation projects, and the conclusions are included in this report.



# Table of Contents

|   |           |
|---|-----------|
| <b>CHAPTER 1. Introduction .....</b>  | <b>1</b>  |
| Objective .....   | 1         |
| Organization of Report.....   | 1         |
| <b>CHAPTER 2. Summary of Pilot Training.....</b>  | <b>3</b>  |
| Development of Training Materials .....   | 3         |
| Contents of Training Modules.....   | 3         |
| Delivery of Training Modules.....   | 4         |
| <b>CHAPTER 3. Data Collection in Districts.....</b>   | <b>5</b>  |
| Introduction .....  | 5         |
| Evaluation of Relationship between Engineering Properties as Determined by Spot<br>Tests and ICMV ..... | 9         |
| <b>CHAPTER 4. Development and Use of IC Database .....</b>  | <b>13</b> |
| Development of Database .....   | 13        |
| Elements of IC Database .....   | 13        |
| <b>CHAPTER 5. Complications and Concerns with Implementation of IC in Districts .....</b>               | <b>17</b> |
| Summary of Complications and Concerns.....  | 17        |
| <b>CHAPTER 6. Cost-Benefit Analysis .....</b>   | <b>19</b> |
| Introduction .....  | 19        |
| Benefit-Cost Analysis .....   | 19        |
| <b>CHAPTER 7. Development of IC Specifications .....</b>  | <b>21</b> |
| Introduction .....  | 21        |
| Materials and Equipment .....   | 21        |
| Compaction .....  | 21        |
| Development of Target Values .....  | 21        |
| <b>References.....</b>  | <b>23</b> |
| <br>  |           |
| Appendix A. REVISED IC SPECIFICATION IN TxDOT SPECIFICATION FORMAT .....                                | 25        |
| Appendix B. TRAINING EVALUATION FORM USED IN WORKSHOPS .....  | 37        |
| Appendix C. LIST OF SITES.....  | 39        |
| Appendix D. INTELLIGENT COMPACTION DATA COLLECTION .....  | 41        |
| Appendix E. GPS CALIBRATION PROCESS.....  | 45        |
| Appendix F. FIELD EVALUATION AT PARIS DISTRICT, STATE HIGHWAY (SH) 24.....                              | 47        |
| Appendix G. FIELD EVALUATION AT FORT WORTH, IH 35W HIGHWAY .....  | 57        |



## List of Figures

|  |    |
|--|----|
| Figure 2.1 – IC Training Workshop in (a) Waco and (b) San Antonio. ....  | 4  |
| Figure 3.1 – Schematic of a Typical Test Section and Locations of Spot Tests.....                                      | 6  |
| Figure 3.2 – Nondestructive Tests Carried out during This Study. ....  | 7  |
| Figure 3.3 – Color-Coded Map Depicting IC Data.....  | 9  |
| Figure 3.4 – Spatial Distribution of (a) CMV Data Collected by IC Roller (b) LWD. ....                                 | 10 |
| Figure 3.5 – Relationship between averaged LWD Modulus and vs CMV. ....  | 10 |
| Figure 3.6 – Spatial Distribution of (a) CMV Data Collected by IC Roller (b) DCP. ....                                 | 11 |
| Figure 3.7 – Spatial Distribution of (a) CMV Data Collected by IC Roller (b) LWD. ....                                 | 11 |
| Figure 3.8 – Spatial Distribution of LWD Modulus at PLT Location for Case Study<br>Performed in I-35W, Fort Worth..... | 12 |
| Figure 4.1 – Flowchart of Collecting and Preparing IC Data to Update the IC Database.....                              | 13 |
| Figure 4.2 – Interactive Graphical User Interface of the Developed IC Database. ....                                   | 15 |
| Figure 5.1 – Non-Vertical Mounting of Retrofit Accelerometer.....  | 17 |
| Figure 6.1 – Flowchart to Calculate Compaction Costs (after Savan et al. 2016).....                                    | 20 |
| Figure 7.1 – Criteria for color-coded map of ICMV data.....  | 22 |

## List of Tables

|   |    |
|---|----|
| Table 3.1 – Criterion for Color-Coded Maps.....     | 9  |
| Table 4.1 – Elements of Developed IC Database ..... | 14 |



## **CHAPTER 1. INTRODUCTION**

The Texas Department of Transportation's (TxDOT) current practice for field compaction quality control and acceptance for soil and base layers is to determine the compacted density and occasionally moisture content by nuclear density gauge (NDG). TxDOT has considered several stiffness-based devices to replace density measurement because stiffness parameters are more relevant to and used in pavement design. Since both density and stiffness measurements are spot tests, they cannot represent the quality and uniformity of compaction in a continuous manner.

Conventional proof-rolling is oftentimes specified by TxDOT as a way of evaluating the uniformity of the compacted materials. Proof-rolling or mapping subgrade and base using the intelligent compaction rollers after completing compaction can effectively identify the less stiff spots and significantly improve the compaction uniformity of the compacted layers.

Intelligent Compaction (IC) is a fast-developing technology for soil and base compaction quality control. This technology allows a continuous assessment of the overall stiffness through roller parameters (frequency, amplitude, and speed). Integrated with a global positioning system (GPS), IC provides a complete compaction and geographic information (Mooney et al., 2010). European countries have implemented specifications of IC technology for soils and bases. Many studies in the United States have been carried out to understand and implement the IC technology.

The main goal of this project is to capitalize on the new Intelligent Compaction (IC) specification for implementation of IC technology that was developed through TxDOT research project 0-6740.

### **Objective**

The specific objectives of this project are the following items:

1. developing and deploying a training program for TxDOT engineers and inspectors;
2. supporting the districts in implementing the IC technology;
3. implementing a field monitoring program to quantify the benefits of the IC technology; and
4. assisting TxDOT Construction Division (CST) in evaluating and incorporating the new IC specification into the new specifications book.

To achieve these objectives, a number of tasks were proposed and completed. These tasks include:

- Task 1. Develop Training Program Materials
- Task 2. Conduct Pilot Training
- Task 3. Conduct District Training
- Task 4. Implement Intelligent Compaction in the Districts
- Task 5. Implement Field Monitoring Program, and
- Task 6. Incorporate Intelligent Compaction into Specification Book

### **Organization of Report**

In addition to this introductory chapter, the report consists of the following six chapters:

- Chapter 2 provides a summary of the process for conducting the pilot training.
- Chapter 3 summarizes the process of data collection during the implementation of IC in the participating districts. This includes the selection of test sections, spot tests, IC data collection, GPS calibration, and geospatial analysis.

- Chapter 4 documents the development of a comprehensive IC database and its elements during the implementation of IC in TxDOT.
- Chapter 5 lists the major issues encountered during the installation, operation, data collection, data reduction and analysis of the IC systems.
- Chapter 6 summarizes different approaches to evaluate the cost benefit of the IC technology implementation.
- Chapter 7 outlines the research and test procedures for developing two different specifications.

In addition to these chapters, the following seven appendices complement this report:

- Appendix A includes the revised specification and a field test procedure for implementing intelligent compaction.
- Appendix B contains the training evaluation form used in the workshops provided to TxDOT Districts' personnel.
- Appendix C includes the list of sites visited by the research team to conduct IC and field testing.
- Appendix D provides information about the IC data collection process as well as data management.
- Appendix E describes the GPS calibration process.
- Appendices F and G include a summary of the test results as two examples in Paris District and Fort Worth District, respectively.

## **CHAPTER 2. SUMMARY OF PILOT TRAINING**

### **Development of Training Materials**

The purpose of the training materials are to familiarize attendees with fundamentals of IC, the critical components for a successful implementation and the critical aspects of the specifications. The research team, in conjunction with the Project Management Committee (PMC), developed eight comprehensive training modules covering a wide range of information about IC technology and implementation. It purposely targets on different groups of participants including TxDOT engineers and inspectors, contractors, and roller operators. The topics in these training modules are:

- Fundamental Concepts of IC Technology;
- IC Roller/Retrofit Kit Installation and Calibration;
- GPS Installation and Calibration including GPS Reference Station Setup and Configuration;
- IC Roller/Retrofit Kit Operation and Maintenance including Data Collection, Saving, and Delivery to the Engineer;
- IC Data Analysis and Report including Statistical Analysis, Color-Coded Map Generation, and Delivery to the Engineer;
- IC Operator Certification Program including the Pre- and Post-Operation Checklist and Frequently Asked Questions (FAQ);
- Managing IC Data with VisionLink; and
- IC Data Management with Veta<sup>®</sup>.

### **Contents of Training Modules**

The following three sets of training materials were developed and delivered. These materials were:

- Instructor's PowerPoint Presentation with video clips showing step-by-step procedures,
- Instructor's Manual, and
- Student's Manual.

The instructor's presentations were designed to cover a wide range of information regarding the implementation of intelligent compaction for soils and base materials in Texas. These materials were aimed to train different groups of professionals dealing with construction, quality management and maintenance of transportation infrastructures inside TxDOT. As a part of the "Train the Trainer" objective in this project, a comprehensive set of instructor's manuals were also developed following the standards of the National Highway Institute (NHI) of the Federal Highway Administration (FHWA). These manuals contain the following four major sections:

- Key message (contains the key topic(s) that will be discussed during that slide)
- Background information (any information necessary to discuss prior to the discussion of the slide contents)
- Interactivity (the activities that involves students in the slide contents in an interactive manner)
- Notes (any additional notes that needs to be reminded during the slide)

## Delivery of Training Modules

The pilot training session was arranged and conducted on Friday March 20, 2015 with PMC representatives at TxDOT's office in Austin, Texas. All the modules within the training materials were reviewed and discussed with the PMC members and their feedback and comments were implemented in the revised version of the training materials. The contents and format of the training materials were approved by the PMC and arrangements were made to conduct the training workshops at five districts within TxDOT.

An online invitation webpage with online RSVP option was designed to be distributed between the target trainees (<http://ictxdot-cc.splashthat.com>). A link to access the training materials through an exclusive webpage dedicated to this training project was also provided to the trainees to download and review the workshop materials (<http://ctis.utep.edu/6740/>).

Arrangements were made to perform the additional training workshops in Bryan, San Antonio, Corpus Christi, and the Waco districts (see Figure 2.1).

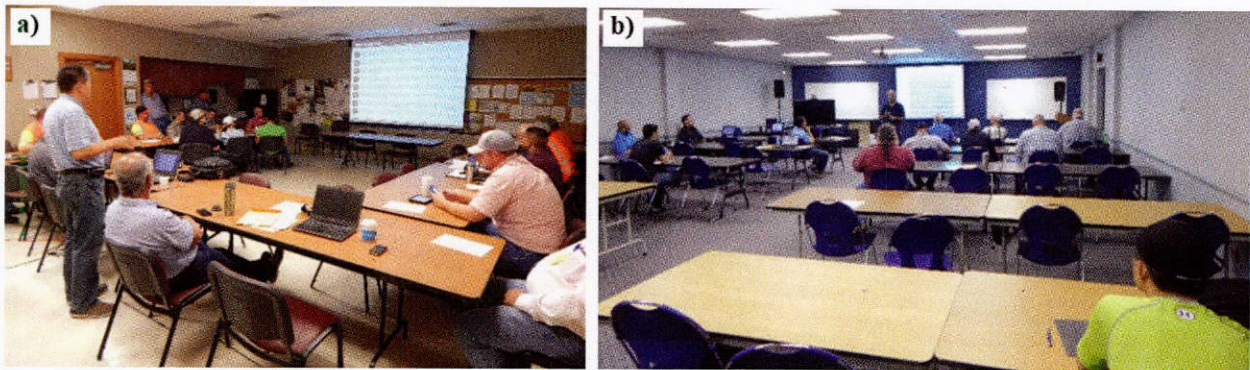


Figure 2.1 – IC Training Workshop in (a) Waco and (b) San Antonio.

To collect feedback and comments of the attendees during each workshop, a short survey questionnaire was also designed and distributed during the district training sessions. The short survey of the training evaluation is included in Appendix B. Questions, comments and concerns that were brought up during the workshops were included to improve the future workshops as discussed in Chapter 5.



## CHAPTER 3. DATA COLLECTION IN DISTRICTS

### Introduction

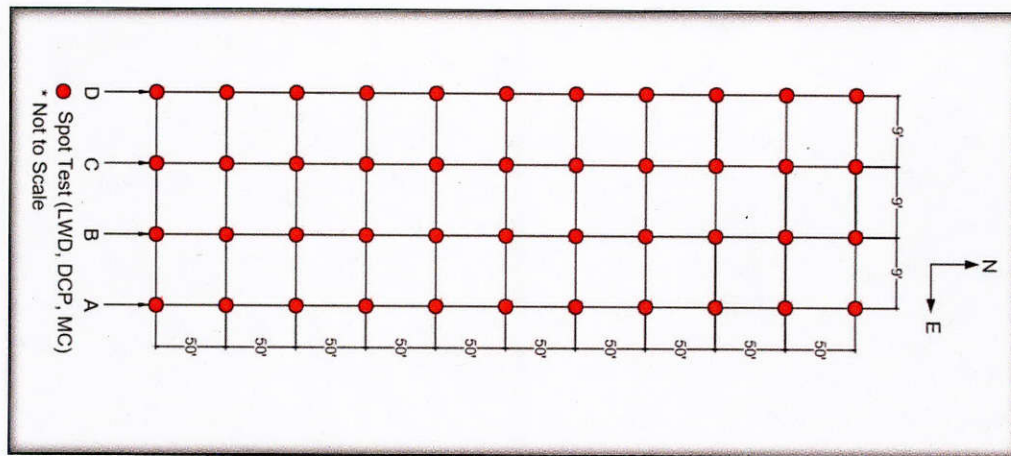
To understand and accelerate the implementation, IC was deployed in various sites in different districts along with field spots tests. The activities performed at the site consisted of the following:

- On-site preparations with contractor personnel.
- Setup of IC data acquisition system.
- Setup and calibration of GPS equipment for IC.
- IC proof-rolling for the measurement of the Intelligent Compaction Measurement Value (ICMV).
- In-situ spot tests:
  - Light-Weight Deflectometer (LWD)
  - Dynamic Cone Penetrometer (DCP)
- Additional in-situ spot tests at some sites:
  - Falling Weight Deflectometer (FWD)
  - Nuclear Density Gauge (NDG)
  - Plate Load Test (PLT)
- Extraction of compacted geomaterial samples for moisture content determination.

Appendix C provides a list of the sites IC data were collected. Following the IC data collection, various in-situ spot tests were performed. The post analyses of the IC data collected are summarized in this chapter.

***On-Site Preparations for ICMV Data Collection.*** The IC data collection process required close interaction with the roller operator and other contractor personnel in selecting the area for proof-rolling of the test section. Recommendations were provided to the operator on the roller speed selection and data recording procedures as provided in the Appendix A, “Test Procedure for Determining ICMV using IC”. On-site preparations also included the installation of the data acquisition system developed by The University of Texas at El Paso (UTEP) and GPS equipment setup and calibration. Both procedures are described in detail in Appendix D and E, respectively.

***In-Situ Spot Tests Procedure.*** In addition to the IC data collection, in-situ spot tests were carried out to investigate the relationships between the IC measurements and engineering properties determined by conventional NDT methods. For this purpose, a test section was selected within each construction site. Figure 3.1 illustrates the schematic of a typical test section and spot test grid. The research team usually marked 44 test points for spot testing.



**Figure 3.1 – Schematic of a Typical Test Section and Locations of Spot Tests.**

At least one or more of the following spot tests were performed on the compacted section at specified test points:

- **Light-Weight Deflectometer (LWD)** is a portable version of FWD that has been developed as an alternative in-situ testing device to the plate load test as shown in Figure 3.2a. The LWD imparts an impulse load through a load plate, and measures the deflection of either the soil surface or of the load plate itself, through a displacement sensor. Similar to FWD, the LWD determines the stiffness of the pavement system by measuring the material's response under the impact of a load with a known magnitude and dropped from a known height. LWD reports the composite stiffness of the layers with the estimated depth of influence of up to 6 ft (Tirado et al, 2015). The LWD tests were performed in accordance with ASTM E2583 in this project.
- **Dynamic Cone Penetrometer (DCP)** test involves driving a cone shaped probe into the soil or aggregate layer using a dynamic load and measuring the advancement of the device for each applied blow or interval of blows as shown in Figure 3.2b. The depth of penetration is directly impacted by the drop height, the weight, cone size, and cone shape. Moreover, the resistance to penetration is dependent on the shear strength of the material. The strength, in turn, is dependent on the density, moisture content, and material type. The standard test method, ASTM D6951, was followed to perform DCP tests. Then California Bearing Ratio (CBR) was calculated from DCP penetration index. After that, modulus was calculated using the CBR values based on the US Army Corp Engineer's recommended equation. .



**Figure 3.2 – Nondestructive Tests Carried out during This Study.**

- **Falling Weight Deflectometer (FWD)** is a nondestructive field test to assess the material properties under simulated traffic loads when performed on top of the finished pavement. The FWD measures the pavement deflection at seven points (with 12 in. interval) for a given load, as shown in Figure 3.2c. The pavement layer parameters, FWD load and measured deflections are used to backcalculate the modulus of each pavement layer.
- **Plate Load Test (PLT)** is a field test for determining the ultimate bearing capacity of soil and the likely settlement under a given load. The Plate Load Test as per Tex-125-E basically consists of loading a steel plate placed at the foundation level (as shown in Figure 3.2d) and recording the settlements corresponding to each load increment.
- **Nuclear Density Gauge (NDG)** as per Tex-115-E.
- **Moisture Content Test** as per Tex-103-E.

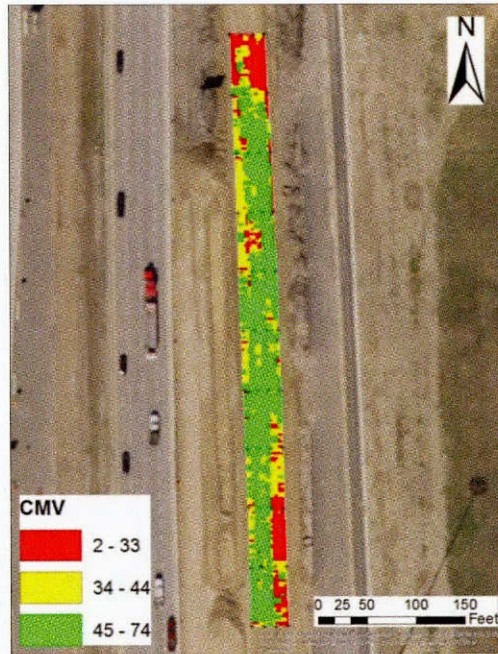
Geostatistical and geospatial data analysis techniques were employed to visualize and interpret the IC data. The IC data, in the generic form of ICMV, is best described and interpreted as color-coded maps. These maps display the geo-referenced or spatial data on a map in which each class is separated by different colors. In this study, three colors, green, yellow and red, are used for creating a color-coded map. The goal of using the ICMV color-coded maps is to identify the less stiff areas (usually marked as red spots) and to improve the uniformity of compaction throughout the construction area. Veta® and ArcGIS are two common used software programs for the IC data

analysis and mapping. Each tool has its own advantages and limitations. Veta<sup>®</sup> is a specialized Intelligent Construction Data Management (ICDM) analysis tool with a user-friendly interface that allows to display, analyze, and report data as collected by different IC rollers. It is required as a standard tool in the FHWA, AASHTO, and many State DOT's specifications. ArcGIS is a more general used commercial program. It provides more flexibility for rigorous analyses and visualization to highly trained users. Both tools were employed in this project to present the collected IC data. The IC data were exported from the vendors' data management tool to a "csv" format file. The processes of the IC data analyses with each software are briefly summarized in the following steps:

- Import .csv data file into the software environment
- Display the IC data on the map based on the coordinate system used during data collection. The Universal Transverse Mercator (UTM) system employs Northing and Easting coordinates to locate the data points. The geographical coordinate system uses Latitude and Longitude data. Both UTM and geographical coordinate systems are used to collect and analyze IC data in this project
- Identify the boundaries to select the desired test section from the total covered area and filter the IC data within the boundary limits
- Perform geostatistical analyses on the collected IC data to generate customized color-coded maps and reports

To begin the geostatistical analyses of the data using ArcGIS, the color-coded geospatial distribution maps are created using an interpolation algorithm to predict values for the total covered area within the previously identified boundaries. ArcGIS offers different interpolation methods which could be employed for the geospatial process. After extensive search, two different interpolation methods have been utilized during the analysis of the data collected in the districts. The first one was the Empirical Bayesian Kriging interpolation algorithm which considered both the distance and the degree of variation between known data points when estimating values in unknown areas. The second option used was the Spline interpolation method. The Spline method estimates values using a mathematical function that minimizes overall surface curvature, resulting in a smooth surface that passes exactly through the input points. For the geostatistical processes used, the Kriging method considerably reduced the range of values of the interpolated data by cropping valid ICMV values that the other kriging model took as outliers. For that purpose, the Spline interpolation method was preferred over the Kriging method but still other issues arise with this last method such as the potential of negative interpolations. ArcGIS offers additional interpolation methods which can be reviewed to create the color-coded distribution maps.

After an interpolation method was chosen, a color criteria had to be selected. The IC data were best described and interpreted as color-coded maps as shown in Figure 3.3. These maps display the georeferenced or spatial data on a map where each class is separated by different colors. An understanding of the spatial pattern of the ICMV data is dependent on the optimal selection of both the number of classes and the values of the class breaks. The use of more than three colors is common in many geospatial and cartographic analysis. In the case of the IC data, the three colors as green, yellow, and red are considered practical. The goal of using the ICMV color-coded maps is to identify the less stiff areas (usually marked as red spots).



**Figure 3.3 – Color-Coded Map Depicting IC Data.**

Different classification methods can be used during the development of the color-coded maps. One of the classification methods used is the Quantile method, where each class contains an equal number of data points. This classification method did not seem appropriate for the geospatial analysis since it would unavoidably mark some less stiff areas even if uniform compaction of the soil was reached. Other classification methods are based on measurements of the data collected, such as the standard deviations and the mean. Table 3.1 shows the criteria for color-coded maps based on the mean value of the data. Under Project 0-6903, a process is being developed for the determination of the most appropriate color-criterion which would help identify the less stiff areas more accurately.

**Table 3.1 – Criterion for Color-Coded Maps.**

| <b>Color</b> | <b>Criterion</b> |
|--------------|------------------|
| Red          | < 0.75 Mean      |
| Yellow       | 0.75 Mean - Mean |
| Green        | > Mean           |

### **Evaluation of Relationship between Engineering Properties as Determined by Spot Tests and ICMV**

The relationships between the measurements and mechanical properties determined by conventional NDT spot tests and ICMV data were studied at every visited site. The cases studies for SH 24, in Paris, and IH 35W, in Fort Worth, are provided in Appendices F and G, respectively. The findings and relationships found between the NDT spot tests and ICMV data are summarized as follows:

- Figure 3.4 shows a comparative observed in the subgrade in SH 24 in Paris. A visual comparison between the LWD and CMV maps indicate that there seems to be a relationship between LWD surface modulus,  $E_{LWD}$ , and ICMV. In the figure, both the IC roller and the LWD testing indicate less stiff areas around the northeastern part of the test section.

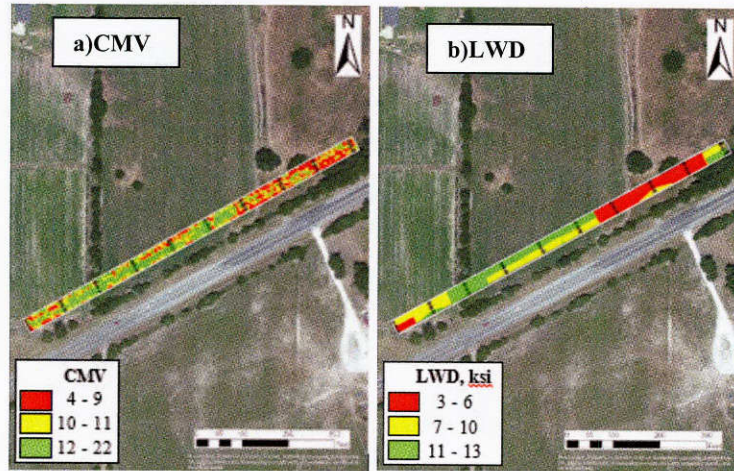


Figure 3.4 – Spatial Distribution of (a) CMV Data Collected by IC Roller (b) LWD Modulus.

- Strong correlation was not observed between the LWD surface modulus and ICMV at that same location. Likewise, no strong correlation was observed between the number of DCP blows and ICMV at the spot test level. However, for most cases, a reasonably strong correlation was observed when the test spots within each station were averaged as illustrated in Figure 3.5 and explained in the appendices. The center part of the test section showed higher LWD moduli and ICMVs than the ends of the test section. In addition, average LWD moduli in the center part of the section were greater than the LWD target modulus while the values reported at the ends of the test section were lower.

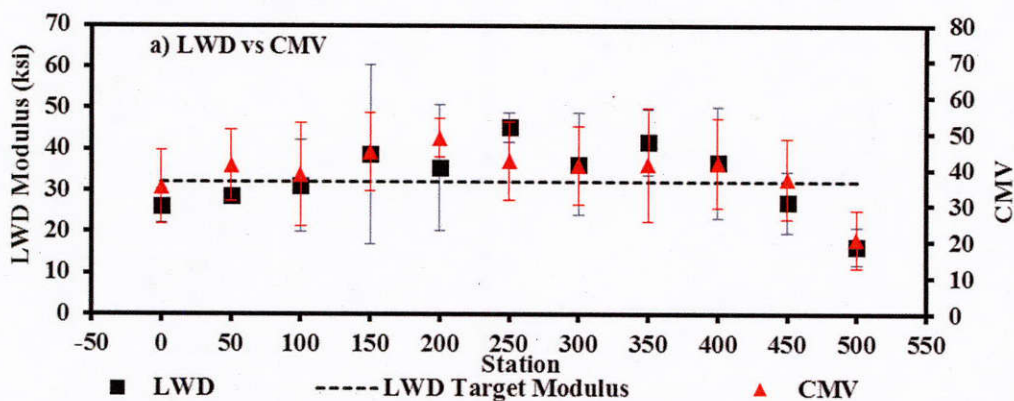
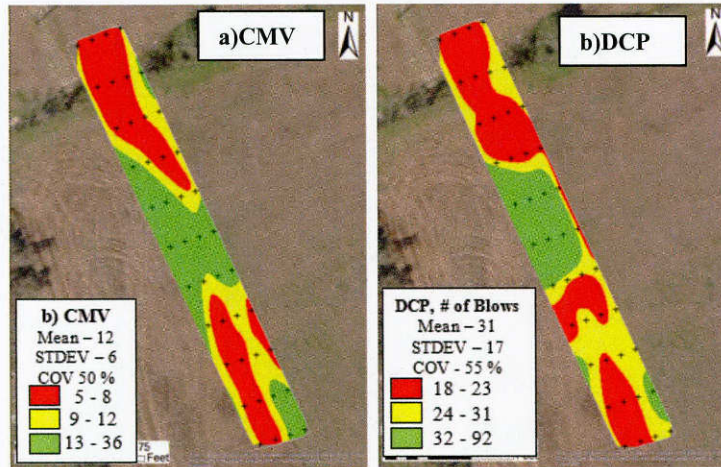


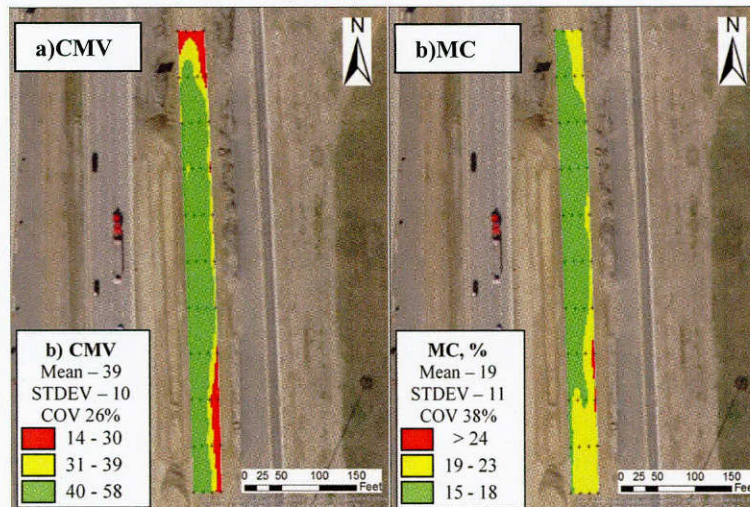
Figure 3.5 – Relationship Between Averaged LWD Modulus vs. ICMV.

- Similar to LWD, a visual relationship seems to be available between the number of DCP blows and the CMV color-coded maps. Figure 3.6 shows a comparative observed in the subgrade in FM 1460 in Georgetown. In this figure, both the IC roller and the DCP testing indicate less stiff areas around the north and south parts of the test section.



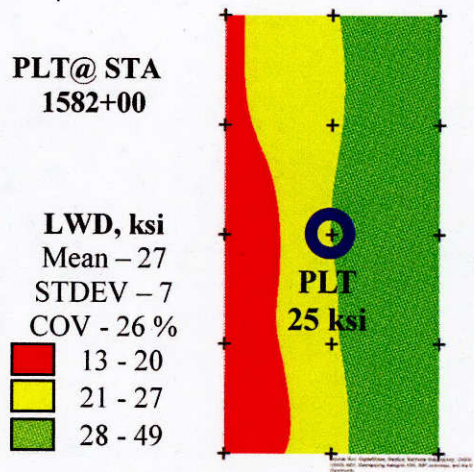
**Figure 3.6 – Spatial Distribution of (a) CMV Data Collected by IC Roller (b) DCP Blows.**

- A visual relationship could also be observed for some of the case studies between the moisture content and the CMV color-coded maps. Figure 3.7 illustrates the spatial distribution of the moisture content found at the surface of the LTS layer in IH 35W. Throughout the test section, the areas with lower moisture content are in agreement with the stiffer areas found in the CMV data. In some of the other case studies, there were no well defined visual relationships between moisture content and CMV nor with other modulus-based measurements. A reason for this can be attributed to the uniformity of moisture content throughout the test section leading to very minor areas to be colored in red indicating higher moisture. More studies will be performed to find a correlation between moisture content and CMV.



**Figure 3.7 – Spatial Distribution of (a) CMV Data Collected by IC Roller (b) Moisture Content.**

- The results from a few PLT tests over a wide area should be considered with caution. The selection of the test spot may skew the results. Because of the long duration of the PLT test lasting about 2 hours, few PLT tests were executed. The LWD spot testing done around the PLT test locations demonstrated the variability of the materials around the PLT test (see Figure 3.8).



**Figure 3.8 – Spatial Distribution of LWD Modulus at PLT Location for Case Study Performed in IH 35W, Fort Worth.**



## CHAPTER 4. DEVELOPMENT AND USE OF IC DATABASE

### Development of Database

In an attempt to implement IC within TxDOT, the research team developed a comprehensive and interactive database. A close collaboration between the contractor, TxDOT engineers and the research team were required to develop this database.

Figure 4.1 illustrates the typical order of IC data collection, reduction and analysis in the context of developing a comprehensive IC database. Each step in this flowchart involves more details that will be discussed in the following sections.



Figure 4.1 – Flowchart of Collecting and Preparing IC Data to Update the IC Database.

### Elements of IC Database

The IC database basically contains two sections. The section for input data which consists of the following items:

- **Project Details.** Detailed information for each project is provided in the database. This information is listed in Table 3.1. Obtaining this information for the IC project and updating the database are required to maintain the correct record of the IC data and facilitates the extraction of reports.
- **Layer and Material Properties.** Table 4.1 summarizes different material and layer types investigated during this project. The types of materials as well as the layer specifications were recorded and maintained in the database.
- **IC Roller Specification.** Table 4.1 summarizes different specification of IC rollers as it appears in the database. The type of IC roller and the roller specification is important in both data collection and analysis. The type of IC roller drum also affects the collected IC data. The database also identifies whether the IC roller is an Original Equipment Manufacturer (OEM) or retrofitted.
- **Spot Test Data.** Table 4.1 summarizes the existing spot test information in the current version of the IC database. If applicable, the results of spot tests are included in the database. The most common type of spot tests required by TxDOT is the nuclear density

gauge (NDG). The results of the NDG dry density and moisture content tests are included in the database. The other types of spot tests that could be added to the next versions of the database are the FWD, LWD and DCP.

**Table 4.1 – Elements of Developed IC Database**

| Input Data                |                                     |   |                      | Analysis Results    |                         |                   |
|---------------------------|-------------------------------------|---|----------------------|---------------------|-------------------------|-------------------|
| Project Details           | Material Types and Layer Properties | IC Roller Specification                     | Spot Test Data       | IC Reports and Maps | ICMV Statistics         | Color Code Ranges |
| Control-Section-Job (CSJ) | Cement-Treated Base (CTB)           | Roller type (vendor)                        | NDG Moisture content | Software report     | Average                 | Green             |
| Project location          | Flexible Base (FB)                  | Roller model                                | NDG Dry density      | CMV color map       | Minimum value           | Yellow            |
| District                  | Lime-Treated Subgrade (LTS)         | Drum type (padfoot, sheep's foot or smooth) |                      | Software file       | Maximum value           | Red               |
| Year                      | Embankment                          |   |                      |                     | Standard deviation      |                   |
| Month                     | Subgrade                            | IC system (OEM or retrofit)                 |                      |                     | Coefficient of variance |                   |
| Day                       | Base                                |   |                      |                     | Sample size             |                   |
| Station No.               |                                     |   |                      |                     |                         |                   |
| Design file name          |                                     |   |                      |                     |                         |                   |

The second section of the IC database includes the results of the data analyses. Figure 4.2 illustrates a sample data inquiry results from the interactive user interface of the developed IC database. The summary report of the ICMV data as well as the color-coded map and the Veta® file are available for users to download. This section contains the following information:

- **IC Reports and Maps.** Basic analyses of the collected IC data are included in the database. The results of Veta® analysis in the format of a document includes basic statistical analysis of the IC data. The original Veta® file is also available for users to download and perform additional analysis. The color-coded map of the IC data, generated by Veta®, is also available for download. Although this detailed information is provided in the IC database, users can easily select the desired project section from the main interface of the database and view the histogram of the ICMV data as well as the color-coded map of the collected ICMV, both generated by Veta®. This is an interactive feature of the IC database that users can easily switch between different sections to view the summary of collected IC data.
- **ICMV Descriptive Statistics.** Another feature of the IC database is summarizing the descriptive statistics of the collected ICMV data for a project or a specific section. The statistical summary of the ICMV data includes the items shown in Table 4.1.
- **Range of ICMV Color Codes.** Based on the selected classification method, the range of three basis color codes (green, yellow and red) are displayed in the IC database user interface. This range is also dependent on the analysis tool used for interpretation of ICMV data. Within the districts selected in this project, both Veta® and ArcGIS tools were employed to analyze the ICMV data and generate the color-code ranges as well as the maps.

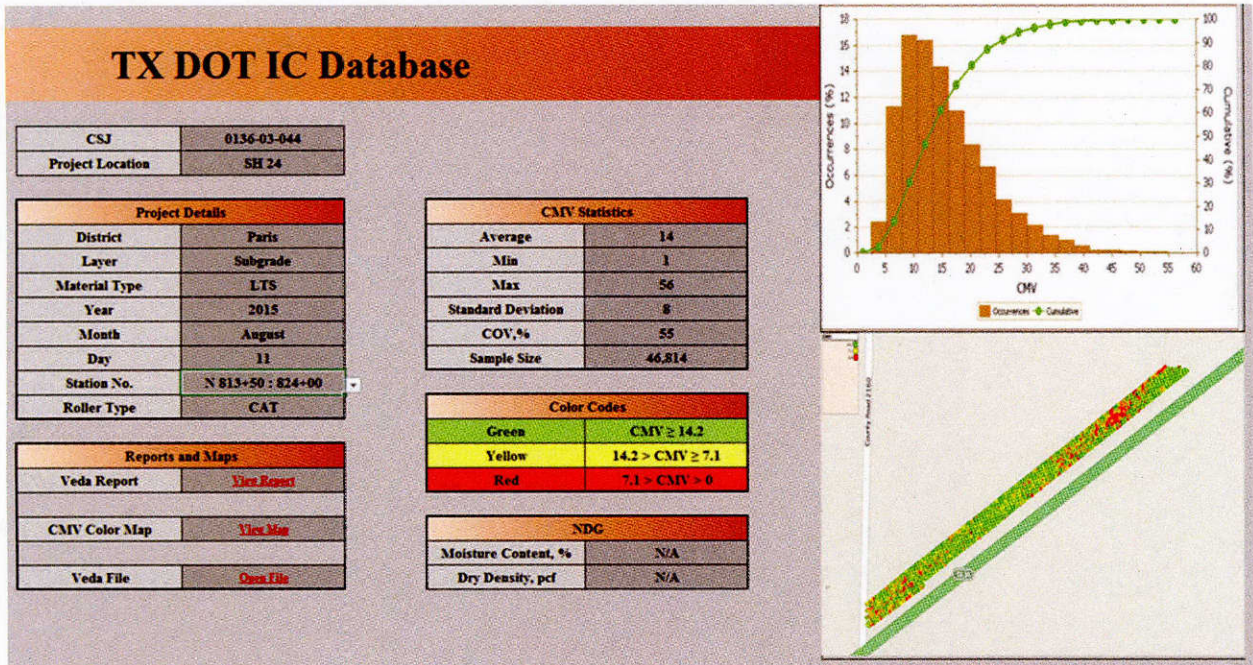


Figure 4.2 – Interactive Graphical User Interface of the Developed IC Database.



## CHAPTER 5. COMPLICATIONS AND CONCERNS WITH IMPLEMENTATION OF IC IN DISTRICTS

### Summary of Complications and Concerns

Close interaction with the PMC and the participating districts helped in addressing some of the complications and concerns that arose with the implementation of the IC technology. The complications and concerns are listed below.

#### ▪ *Preparations for Proof-Mapping*

- *Installation of IC retrofit kit:* No written guidance or manual was available for the installation of the IC retrofit kit (after-market kit) when used as an alternative option for original equipment manufacturer (OEM) IC systems. Improper installation of the retrofit kit would produce inconsistent results and undesirable variability in ICMVs. A common problem was the mounting of the retrofit accelerometer deviating from a 90° angle with respect to the horizontal required for adequate measurements, as shown in Figure 5.1.



Figure 5.1 – Non-Vertical Mounting of Retrofit Accelerometer.

Retrofit kits should be installed by a certified technician to ensure proper operation. The installed system should be carefully checked to ensure that the components are properly connected and that the vibration sensor is mounted vertically, securely and in a position that can capture the actual vibration of the drum. The roller configuration and installation parameters should be defined as part of the installation of the in-cab control box. In some IC systems, the design file could be uploaded for better understanding of the roller position during the operation. A dry run on a test section should be performed prior to the IC data collection process.

#### ▪ *Operation of IC Roller*

- *Setting of roller operating parameters for compaction:* Neither guidance nor written manuals were available to operators. Though not overly complicated or time consuming, training is only offered by the manufacturer when the equipment is purchased, leased, or rented. In addition, a standard is needed for setting up operation parameters such as amplitude, frequency and speed.

- **Process to validate GPS system:** A GPS validation process should be performed prior to any data collection. Either a physical or virtual base station along with a hand-rover could be utilized to perform the calibration process. The corrected GPS coordinates should be applied to the in-cab control settings.
- **Data collection of ICMVs:** A concern that operators and supervisors shared related on how would the roller operator be notified if the retrofit kit system did not collect the data correctly and completely. To address this issue, the design file should be uploaded immediately after the mapping.
- **Data Management**
  - **Upload/download of IC roller data to web-based data management system:** A guide or manual on the data upload to and download from online data management systems was needed. Different vendors offer their own data management systems (e.g., VisionLink for Trimble/CAT, SiteLink3D for Topcon/Sakai and HAMM Compaction Quality navigator). Among the concerns raised was the question on how frequent the data should be uploaded and updated, and the amount of time for data download from those web-based hosts. In addition, a concern was raised on the availability of data after upload in the web-based host. For contractors to efficiently make use of IC data, it must be available immediately upon completion of mapping. Since operational malfunction or missing data without the knowledge of the QC manager/technician can occur, the collected data should be downloaded hourly, either from the cloud storage or locally using a thumb drive, and checked to ensure integrity of the data.
  - **Date/time filter criteria for data download:** The online data management websites allowed data download with different time criteria based on *date* and *machine design file* filters. However, if the range of time selected was not identical in both filters, an error could occur. To fix this issue, data must be downloaded with the same date and time on both filters.
- **Data reduction and analysis**
  - **Incomplete ICMV records:** Failure on the data collection can occur, causing gaps in the information (e.g., GPS data are stored with no records of ICMVs, or vice versa). The collected data should be downloaded daily and checked to ensure integrity of the data by removing records with no ICMV data.
  - **Records with ICMV data not tied to proof-rolling:** ICMV data is constantly being recorded even when the roller is not in the vibratory mode. In addition, amplitude and frequency records may not be recorded properly. In this scenario, it is difficult to determine if the ICMV reading is correct.
  - **Sequentially of data:** Databases may contain time stamps not reported in a sequential manner. This issue has been observed when identical GPS coordinates are stored, indicating that the issue is tied with the gridding algorithm. To address this issue, post-processing is needed to average ICMVs sharing identical coordinate locations.  
 Since IC data are associated with GPS coordinates, geospatial and geostatistical data analyses should be performed on collected data. Veta<sup>®</sup> is a standard tool to view IC data on the map and perform statistical analysis on the collected data. The ArcGIS package can be used as a research tool to conduct more advanced analyses.

## CHAPTER 6. COST-BENEFIT ANALYSIS

### Introduction

Compaction of pavement geomaterials is critical to obtaining long-term performance of the roadway. With the advent of the IC technology, a greater process control can be achieved to increase productivity of the compaction process. This process control occurs with the monitoring of the IC roller operating conditions (e.g. vibration frequency, amplitude, speed, roller passes). Control on the process is allegedly related to a more uniform compaction, improved stiffness of the materials, identification of non-compacted areas and, ultimately, reduction in compaction costs and highway repair costs.

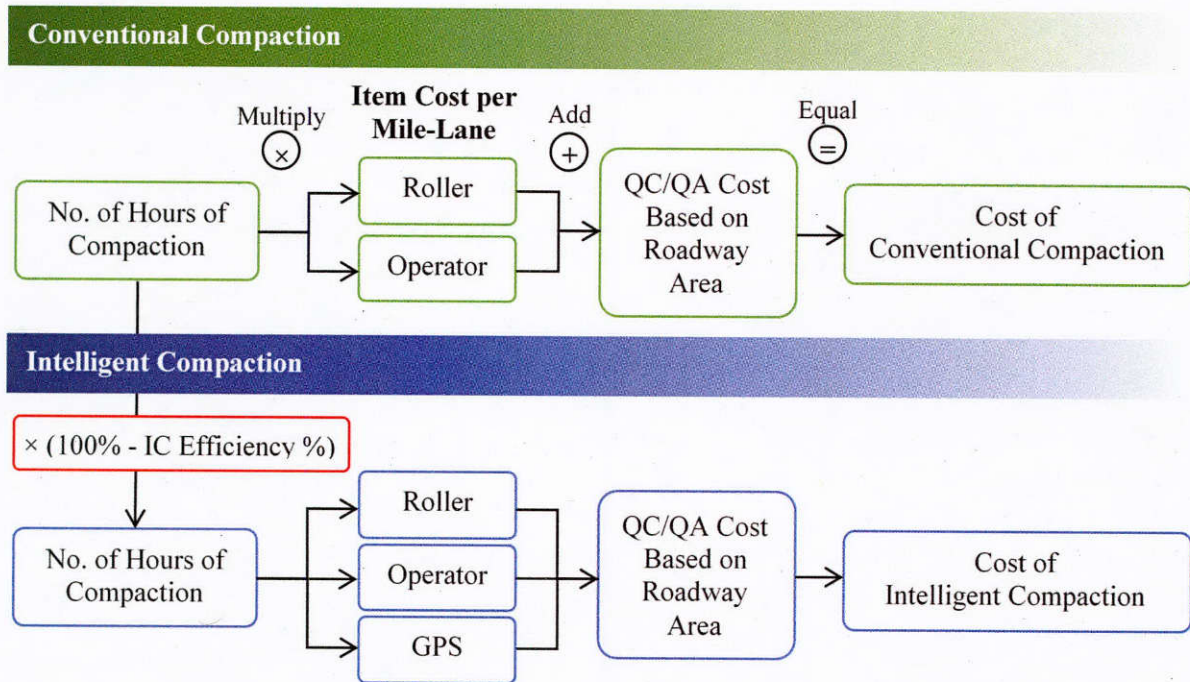
### Benefit-Cost Analysis

Petersen et al. (2006) listed benefits that included improved quality, reduced compaction cost, reduced life-cycle cost, and integration of design with construction and pavement performance. The authors claimed costs were reduced in the short term because compactive effort is applied only where necessary and thicker lifts might be compacted. Long-term costs were reduced because of reduced wear and tear on the compactor. Similarly, Gallivan et al. (2011) discussed the improvement of rolling patterns when IC technology was implemented in field demonstrations. They concluded that benefits included reduced resources, improved production and less re-work. Similarly, Chang et al. (2011) listed among the benefits of the implementation of IC technology the identification of less stiff support areas for corrective actions prior to the compaction of the upper layers and the improvement of rolling patterns under lower visibility conditions.

Savan et al. (2016) developed a framework for a benefit-cost analysis to evaluate the implementation of IC. A flowchart with this framework is shown in Figure 6.1. The framework was based on costs for construction of a roadway (construction cost cycle) and savings from improved compaction uniformity over the pavement life cycle (roadway life cycle cost). They provided a comparison between the two compaction methods; i.e., with and without IC, comprised of a summation of the costs from the two cost cycles over similar construction lengths and roadway life cycles. The authors gathered construction costs regarding roller equipment and labor for conventional compaction using pricing data from contractors.

The traditional construction cost was calculated using the compaction time in hours, the hourly GPS, roller equipment and labor costs, and the QC/QA cost per area. Construction costs for IC were calculated similarly using IC roller costs, with characteristics similar to the conventional roller; e.g., setup, weight and vibratory characteristics. The number of hours required for compaction with IC was determined based on the reduction of number of roller passes to perform roller operations (IC efficiency).

The traditional construction cost was calculated using the compaction time in hours, the hourly GPS, roller equipment and labor costs, and the QC/QA cost per area. Construction costs for IC were calculated similarly using IC roller costs, with characteristics similar to the conventional roller; e.g., setup, weight and vibratory characteristics. The number of hours required for compaction with IC was determined based on the reduction of number of roller passes to perform roller operations (IC efficiency).



**Figure 6.1 – Flowchart to Calculate Compaction Costs (after Savan et al. 2016).**

The roadway life cycle cost per year is calculated based on the capital cost of the roadway improvement divided by the service life of the roadway in years, for both conventional compaction and IC. The authors did not include pavement maintenance costs justifying that the type of maintenance is highly dependent on the transportation agency and roadway characteristics, and its inclusion would complicate the direct comparison between conventional compaction and IC.

The authors evaluated two cases consisting of one lane-mile of a thick asphalt pavement overlay section and a new roadway section of one lane-mile which included subgrade compaction. In the case of the thick asphalt pavement overlay section, the authors assumed a cost of IC was then calculated using a 30% reduction as observed by Briaud and Seo (2003) on a similar compaction work. The benefit from increased uniformity was calculated for the thick asphalt overlay using an increased fatigue life multiplier derived from Chang et al. (2012) and Xu et al. (2012) studies. Those studies evaluated fatigue life for using the MEPDG and finite element models of two pavements: a uniform pavement (as would be compacted allegedly by an IC roller) and a heterogeneous pavement (as would be compacted by a conventional compactor). They concluded the uniform pavement lasted 2.6 times longer than the heterogeneous pavement. Savan et al. used that increased service life as the fatigue life multiplier. Based on their assumptions and calculations the authors were able to provide annual cost savings when the IC technology is implemented. They arrived at a similar conclusion for the second case study that involved subgrade compaction. Though the study made use of current construction costs, they use several assumptions borrowed from other studies. Savan et al. (2016) provided a first attempt to provide a framework to evaluate benefit-cost of the implementation of the IC technology.



## **CHAPTER 7. DEVELOPMENT OF IC SPECIFICATIONS**

### **Introduction**

One of the key objectives of the project is to incorporate IC procedures into the specification for quality compaction of subgrade soils, embankment and bases. A review of Intelligent Compaction specifications was summarized in the final report of TxDOT Project 0-6740. Based on the findings of that study, a specification for compaction of subgrade and base materials was proposed. Under the activities performed in this project, an updated specification was developed based on the findings after review and feedback from the PMC. This specification was implemented on the selected construction sites studied in this project. The developed “Special Specification for Quality Compaction of Soil and Base Using Intelligent Compaction Rollers” is included as part of Appendix A. In the specification, guidelines for furnishing the materials and equipment are provided. Directives for compacting, proof-rolling and acceptance are included as well.

In addition to the special specification, a test procedure under a temporary TxDOT designation Tex-999-E entitled “Test Procedure for Determining Intelligent Compaction Measurement Value (ICMV) using Intelligent Compaction (IC) Technology” was written to address detailed instructions of the operation, measurement of ICMV and the reporting of the measured data. The test procedure is included as part of Appendix A as well, following the special specification.

### **Materials and Equipment**

The specification includes a section for furnishing materials for compaction. After consultation with the PMC, the specification indicates untreated geomaterials must meet the requirements of the plans and specifications in accordance with Item 110, “Excavation,” Item 132, “Embankment,” and Item 247, “Flexible Base,” to ensure suitable compaction. The use of treated/stabilized materials requires further study and, consequently, are not included into the specification as higher spatial non-uniformity has been reported on treated geomaterials.

### **Compaction**

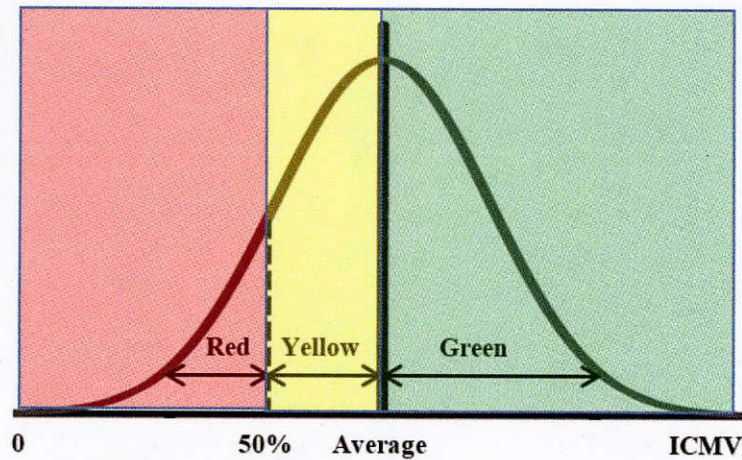
Section 4 of the Special Specification focuses on the compaction and measurement of ICMV using the IC roller. Measurement of ICMV is performed during the proof-mapping, which is the process of using the IC roller to map the section upon completion of compaction for assessing the compaction’s uniformity. Color-coded maps are generated in this process. Based on the obtained maps, density and moisture measurements are taken within red color areas for acceptance purposes. Color-coded criteria is provided in the Tex-999-E Test Procedure.

### **Development of Target Values**

Highway agencies have come up with their own specifications for quality control and acceptance of compaction using IC technology. In general, the quality control and acceptance is based on achieving the target roller measurement values during process control and acceptance. Many methods have been considered for establishing the target values in quality control and acceptance, including:

- Establishment of the required soil density or modulus value to be achieved in the field.
- Calibrating the modulus and roller measurement values for moisture content and variation.
- Determining the target values consistent with the required density or modulus values
- Acceptance testing by comparing the roller measurement values with target values.
- Acceptance based on the percentage change in the roller measurement values.

Acceptance based on the percentage change requires the calculation of the average of the measurements and setting it as the Target Value (ICTV). The IC data will be color-coded using green, yellow and red colors as shown in Figure 7.1. Different criteria has been used for setting the color-coded limits. In this study, two methods were mostly used, consisting of setting the red color for those values below 85% of the mean of all ICMV values, or at 50% below the mean of all ICMV collected data, as shown in Figure 7.1. After consultation with the PMC, in the proposed test procedure, the red color was set to those values below 50% of the ICTV, with ICTV defined as the average IC values.



**Figure 7.1 – Criteria for color-coded map of ICMV data.**

## REFERENCES

- Mooney, M. A., Rinehart, R. V., White, D. J., Vennapusa, P., Facas, N., & Musimbi, O. (2010). *Intelligent Soil Compaction Systems*. Washington, DC: Transportation Research Board.
- Tirado, C., M. Mazari, C. Carrasco, and S. Nazarian. (2015) "Simulating Response of Different Light Weight Deflectometer Testing Using Finite Element Modeling." *Transportation Research Board 94<sup>th</sup> Annual Meeting*, No. 15-2228, Washington, D.C.
- Briaud J.-L. and Seo J. (2003). *Intelligent Compaction: Overview and Research Needs*. Texas A&M University, College Station, TX.
- Chang, G., Xu, Q., Rutledge, J., Horan, B., Michael, L., White, D., and Vennapusa, P. (2011). Accelerated implementation of intelligent compaction technology for embankment subgrade soils, aggregate base, and asphalt pavement materials (No. FHWA-IF-12-002).
- Chang, G. K., Gallivan, V. L., Horan, R. D., and Xu, Q. (2012). "Influences of intelligent compaction uniformity on pavement performances of hot mix asphalt." *Construction and Building Materials*, Vol. 30, No. 1, pp. 746-752.
- Gallivan, V. L., Chang, G. K., and Horan, D. R. (2011). Intelligent compaction for improving roadway construction. In *Emerging Technologies for Material, Design, Rehabilitation, and Inspection of Roadway Pavements*, pp. 117-124.
- Petersen, D., Siekmeier, J., Nelson, C., and Peterson, R. (2006). Intelligent soil compaction technology: Results and a roadmap toward widespread use. *Transportation Research Record: Journal of the Transportation Research Board*, No. 1975, Transportation Board of the National Academies, Washington, D.C., pp. 81-88.
- Savan, C. M., Ng, K. W., and Ksaibati, K. (2015). *Implementation of Intelligent Compaction Technologies for Road Constructions in Wyoming*, Report No. MPC 15-281, Mountain-Plains Region, Consortium, Laramie, WY.
- Savan, C. M., Ng, K. W., and Ksaibati, K. (2016). Benefit-cost analysis and application of intelligent compaction for transportation. *Transportation Geotechnics*, Vol. 9, pp. 57-68.
- Xu Q., Chang G.K., Gallivan V.L., and Horan R.D. (2012). Influences of Intelligent Compaction Uniformity on Pavement Performances of Hot Mix Asphalt. *Construction and Building Materials*, Vol. 30, No. 1, Elsevier, pp. 746-752.



**Appendix A. REVISED IC SPECIFICATION IN TXDOT SPECIFICATION  
FORMAT**

---

# Special Specification XXXX

## Quality Compaction of Soil and Base Using Intelligent Compaction Rollers



---

### 1. DESCRIPTION

Construct roadway embankment, subgrade soil and flexible base (untreated) using Intelligent Compaction (IC) rollers within the limits of the work described in the plans or provision. Provide the IC system integrated directly from the roller manufacturer or equipped with field IC retrofit kits. IC rollers consist of a stiffness type measuring system that records compaction parameters and a Global Positioning System (GPS) or equivalent system that records and documents roller location to ensure that uniformity is achieved through continuous monitoring of compaction.

---

### 2. DEFINITIONS

- 2.1 **Intelligent Compaction.** A technology to collect georeferenced stiffness-based data during and after compaction of geomaterial layers.
- 2.2 **Intelligent Compaction Measurement Values (ICMV).** A set of IC data used to assess the uniformity of compaction for a given compaction area based on IC roller vibration measurements.
- 2.3 **Proof-Mapping.** A process of using an IC roller to map the entire section upon completion of compaction for assessing the uniformity of compaction.
- 2.4 **Intelligent Compaction Retrofit Kit (a.k.a. Aftermarket Kit).** A set of stand-alone IC instrumentation that could be mounted on almost any dynamic vibratory roller to collect ICMV data.

---

### 3. MATERIALS

Furnish uncontaminated materials of uniform quality that meet the requirements of the plans and specifications in accordance with Item 110, "Excavation," Item 132, "Embankment," Item 247, "Flexible Base." Notify the Engineer of the proposed material sources. Notify the Engineer before changing any material source. The Engineer may sample and test project materials at any time throughout the duration of the project to assure specification compliance. Use Tex-100-E for material definitions.

---

### 4. EQUIPMENT

- 4.1. Furnish machinery, tools, and equipment necessary for proper execution of the work in accordance with the plans and the applicable Specification Items listed in Section 3, "Materials."
- 4.2. Provide self-propelled IC rollers or roller equipped with data acquisition (DAQ) systems that processes compaction data in real time for the roller operator. DAQ can be either factory-installed/Original Equipment Manufacturer (OEM) or a retrofit system. IC roller shall be in accordance with the approved IC roller list shown on the Department's Approved Product List, "[Intelligent Compaction Rollers](#)," and comply with the requirements in accordance to Section 3, "Equipment," of Tex-999-E, "Test Procedure for Determining Intelligent Compaction Measurement Value (ICMV) Using Intelligent Compaction (IC) Technology."

- 4.3. Provide a knowledgeable representative from the manufacturer of the IC system in the first two days of construction to ensure proper installation, calibration, and operation of the equipment. Provide personnel capable to operate and maintain the equipment, collect, save, and provide the data to the Engineer. Ensure that these certified personnel attend the on-site training of the IC roller operation provided by the manufacturer's representative.
- 4.4. Provide a GPS or equivalent system to record IC roller locations with detailed coordinate system information required to generate a color-coded map from the IC data. Furnish a GPS or equivalent reference base station required by the IC roller.
- 4.5. Perform the GPS calibration process prior to any IC data collection in accordance to Section 4, "Procedure", of Tex-999-E. Verify that the handheld survey-grade GPS rover(s) and IC roller are connected with the local/virtual base station.

---

## 5. CONSTRUCTION

Construct each layer uniformly, free of loose or segregated areas, and with the required density and moisture content per the plans and the applicable Specification Items listed in Section 3, "Materials." Provide a smooth surface that conforms to the typical sections, lines, and grades shown on the plans or as directed.

- 5.1. **Preparation of Subgrade or Existing Base.** Prepare each area to be excavated or to receive embankment or base in accordance with Item 100, "Preparing Right of Way." Proof-map the finished surface of the existing ground prior to placement of any material in accordance with Item 216, "Proof-Rolling," using the IC roller. Deliver the electronic compaction IC data files to the Engineer in the format specified in Section 4 of Tex-999-E.
- 5.2. **Placing.** Spread and shape the materials into a uniform layer in accordance with the plans and the applicable Specification Items listed in Section 3, "Materials."
- 5.3. **Pulverization.** Pulverize or scarify existing materials in accordance with the plans and the applicable Specification Items listed in Section 3, "Materials."
- 5.4. **Compaction.** Compact the material per the applicable Items specified in Section 3, "Materials." Supply a sufficient number of rollers and other associated equipment necessary to complete the compaction requirements for the specific materials based upon the scope of the project. The IC roller(s) may be utilized during production with other standard compaction equipment. When tamping rollers, such as sheepsfoot or padfoot rollers are used, blade off the depressions upon completion of compaction to provide a smooth surface for proof-mapping. Use IC rollers to proof-map each completed layer. Provide access to the IC data and any computer programs used to generate the color-coded map when required by the Engineer.
  - 5.4.1. Compact the materials for each layer using density control unless otherwise shown on the plans. Compact the materials in accordance with the plans and the applicable Specification Items listed in Section 2, "Materials."
  - 5.4.2. Upon completion of compaction, proof-map the finished layer over the full length and width. Deliver the electronic IC data files and a hard copy or a PDF/JEG type of the color-coded map to the Engineer. The Engineer will establish a roller Intelligent Compaction Target Value (ICTV). The ICTV is the average of the total roller Intelligent Compaction Measurement Values (ICMV) from the electronic IC data files. Provide the IC color-coded map using the same legend as shown in Table 5 in Section 4.6 in Tex-999-E.

- 5.4.3. Final compaction acceptance by the Engineer will be based on the Department-performed field density and moisture content measurements within 24 hours after completion of compaction. The density and moisture measurements shall be taken by the Engineer within the red color areas identified by the IC color-coded map. The Engineer may accept the section if no more than one of the five most recent density tests are below the target density and the failing test is no more than 3 pcf below the target density. In cases of dispute, the sand cone method may be used to determine density in accordance with Tex-115-E, Part II, and moisture content may be determined in accordance with Tex-103-E, Part I.
- 5.4.4. Rework, recompact, and refinish material that fails to meet the applicable Specification Items listed in Section 2, "Materials," or that loses required moisture, density, stability, or finish before the next layer is placed or the project is accepted. Continue work until specification requirements are met. Perform the work at no additional expense to the Department.
- 5.5. **Finishing.** Immediately after completing compaction of the final layer, finish the final section in accordance with the plans and the applicable specification items listed in Section 3, "Materials."
- 5.6. **Curing.** Cure the finished section in accordance with the plans and the applicable specification items listed in Section 3, "Materials."

---

**6. MEASUREMENT AND PAYMENT**

The work performed, materials furnished, equipment, labor, tools, and incidentals will not be measured or paid for directly but will be subsidiary to the pertinent Items.



## Test Procedure for

# DETERMINING INTELLIGENT COMPACTION MEASUREMENT VALUE (ICMV) USING INTELLIGENT COMPACTION (IC) TECHNOLOGY



TxDOT Designation: Tex-999-E

Effective Date: XXX 201X

---

## 1. SCOPE

- 1.1 This test method describes the procedure for determining the Intelligent Compaction Measurement Value (ICMV) using Intelligent Compaction technology on compacted geomaterials used in embankments, subgrade and base layers. The test method is used for quality control testing of compacted geomaterials during construction.
- 1.2 The values given in Customary Units are to be regarded as the standard; however, some units are provided in SI. The values given in parentheses are not standard and may not be exact mathematical conversions. Use each system of units separately. Combining values from the two systems may result in nonconformance with the standard.

---

## 2. DEFINITIONS

- 2.1 **IC**— Intelligent Compaction technology is a system that provides continuous assessment of compaction through roller vibration monitoring and integrates a global positioning system (GPS).
- 2.2 **ICMV**—Intelligent Compaction Measurement Value is a generic term that refers to a set of IC data collected during compaction. It is calculated based on the responses of the roller drum vibration measurements in units specific to the roller manufacturer. It is used for assessing the uniformity and consistency of compaction of underlying materials.
- 2.3 **Vibration frequency**—rotational speed of roller drum's lifting off and compaction on pavement surface.
- 2.4 **Vibration amplitude**— height of roller drum's lift from pavement surface during vibratory compaction.
- 2.5 **Roller pass**—the area covered by on width of the roller in a single direction. Roller pass number is the counts of roller machine passes within a given mesh for a construction lift.
- 2.6 **Proof-Mapping**—the process of using an IC roller to map the entire section upon completion of compaction for assessing the uniformity and consistency of compaction.

---

### 3. EQUIPMENT

- 3.1 *Intelligent Compaction (IC) roller* is a vibratory roller equipped with a data acquisition (DAQ) system that processes and display compaction data in real time. DAQ can be either factory-installed/Original Equipment Manufacturer (OEM) or a retrofit system. IC roller shall be in accordance with the rollers shown on the Department's Approved Product List, "Intelligent Compaction Rollers" and comply with the following requirements:
- 3.1.1 IC rollers shall be equipped with accelerometers mounted in or on the side of the drum to measure the interactions between the roller and compacted materials to evaluate the applied compaction effort.
- 3.1.2 *GPS radio and receiver units* shall be mounted on each IC roller to monitor the drum locations and track the number of roller passes. The recorded GPS data, whether from the IC rollers or hand-held GPS rovers, shall be in the following formats:
- *Date*: The date stamp shall be in *yyyymmdd* format.
  - *Time*: The time stamp shall be in *hh:mm:ss.xx*, with a precision of 0.01 seconds required to differentiate sequence of IC data points during post-processing.
  - *Latitude and longitude*: shall be in decimal degrees, *dd.ddddddd*. Longitudes are negative values when measuring westward from the Prime Meridian.
  - *Elevation*: shall be in *dddd.ddd* in foot.

Essential GPS data elements for each data point are shown in Table A.1.

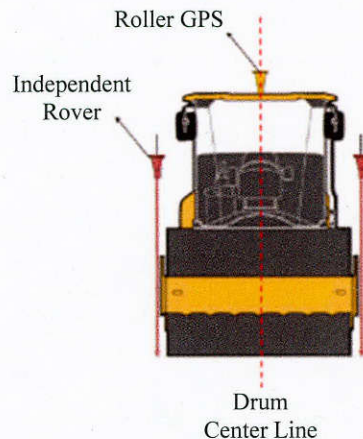
**Table A.1—GPS Data Elements for Each Data Point**

| Item No. | Data Field Name             | Example of Data |
|----------|-----------------------------|-----------------|
| 1        | Date Stamp (yyyymmdd)       | 20150205        |
| 2        | Time Stamp (hh:mm:ss.xx)    | 16:49:31.18     |
| 3        | Longitude (decimal degrees) | -101.8790517    |
| 4        | Latitude (decimal degrees)  | 35.1171165      |
| 5        | Elevation (ft.)             | 737.092         |

- 3.1.3 *On-board computer display* shows the location of the roller, number of passes, amplitude and frequency for vibratory rollers, and provides real-time, color-coded maps of the ICMV. The display unit shall be capable of transferring the data by automatic wireless uploading to a cloud computer storage system. On-board computer should have the capability to measure, record, and export compaction data files containing all compaction parameters specified in Tables A.1 and A.4 in the Comma Delimited Separated Values (\*.csv) format.

## 4. PROCEDURE

- 4.1 Close off the entire testing area from any vehicular or construction equipment for the entire testing period. Clear out any other safety concerns that would impact the testing procedure and safety of the testers prior to testing.
- 4.2 *Calibration of GPS System on IC Roller.* Perform the GPS calibration process prior to any IC data collection. Verify that the handheld survey-grade GPS rover(s) and IC roller are connected with the local/virtual base station.
- 4.3 Move the IC roller slowly to a designated position to allow the GPS header computation to be stabilized to obtain accurate GPS location. Once the roller stops, record the last reading, which is associated with the center of the drum. Record the coordinates of both sides of the drum (Figure 1) using the handheld survey-grade GPS rover that was previously synchronized with the base station. The coordinates of the drum center shall be interpolated from the coordinates of the two sides of the drum. Compare the coordinates reported by the IC roller with the interpolated coordinates from the GPS rover. Adjust the IC roller coordinates to match the interpolated numbers. The tolerance of the differences is 12 in. (300 mm) in the northing and easting directions.



**Figure A.1. GPS calibration process**

- 4.4 Identify the Layer IDs using Project typical sections. The operator must input (or select) the header information using the on-board display, prior to compacting the given material and enter a file name to store IC data.

**IC data file name:** operator should name data file using the following convention: date (yyyymmdd); material type (see Table A.2); traffic direction (NB, SB, WB, EB); lane type (ML, FR, RAMP); Stations (to nearest foot, xxxx+xx to xxxx+xx); PM (proof-mapping); Smooth Drum (SD) or Padfoot Roller (PF).

Example: 20160517-SG-NBML-194015TO196045-PM-SD

**Required fields in header** of each file should contain information about site, material and roller type, see Table 3 for sample header information.

- Design Name, Project ID or Section Title that identifies site. Additional information such as Location Description, Starting Station, Operator, may be added.
- Material Type (Table A.2)
- Roller Model, if provided additional roller characteristics (roller type and weight and drum dimensions) may be excluded
- Roller Type, may be excluded if Roller Model provided
- Roller Drum Width (in.), may be excluded if Roller Model provided
- Roller Drum Diameter (in.), may be excluded if Roller Model provided
- Roller Weight (lbs.), may be excluded if Roller Model provided
- GPS Mode
- GPS Tolerance
- Name Index of ICMV Type
- ICMV Type Unit Index (1: CCV, 2: CMV; 3: E<sub>vib</sub>; 4: H<sub>MV</sub>; 5: K<sub>b</sub>; 6: MDP; 7: Other), when ICMV type name not included

**Table A.2—Material Type Designation Acronyms**

|   | Material Type                   | Acronym |
|---|---------------------------------|---------|
| 1 | Untreated Subgrade Soil         | SG      |
| 2 | Lime Treated Subgrade           | LTS     |
| 3 | Cement Treated Subgrade         | CTS     |
| 4 | Untreated Flexible Base         | FB      |
| 5 | Lime Treated Flexible Base      | LTB     |
| 6 | Cement Treated Flexible Base    | CTB     |
| 7 | Asphalt Treated Base            | ATB     |
| 8 | Embankment                      | EMB     |
| 9 | Other material not listed above | Specify |

**Table A.3—IC Data Information**

| Item No. | Data Field Name     | Example of Data                         |
|----------|---------------------|---|
| 1        | Design Name         | 20150205-LTS-NBML-1715+15 to 1745+45-PM |
| 2        | Material Type       | LTS                                     |
| 3        | Roller Model        | HAMM3412                                |
| 4        | GPS Mode            | RTK Fixed                               |
| 5        | GPS Tolerance (in.) | Medium (2.0 in.)                        |
| 6        | ICMV type           | CMV                                     |
| 7        | ICMV index          | 3                                       |

4.5 Collect the IC data when the compaction of the entire layer is completed. For this purpose, make each pass continuously, regardless of length, by operating the IC roller according to manufacturer’s recommendations to provide reliable and repeatable measurements during proof-mapping, on each lift, using consistent operating settings for the following:

- Low Amplitude and Low Frequency (when in vibration mode)
- Speed = 3 mph (5 km/h)

The output from the roller is designated as the Intelligent Compaction Measurement Value (ICMV) which represents the stiffness of the materials based on the rolling resistance or vibration of the roller drums and the resulting response from the underlying materials.

IC data files must at least include the following information in Table A.4.

**Table A.4—IC Data Elements for Each Data Point**

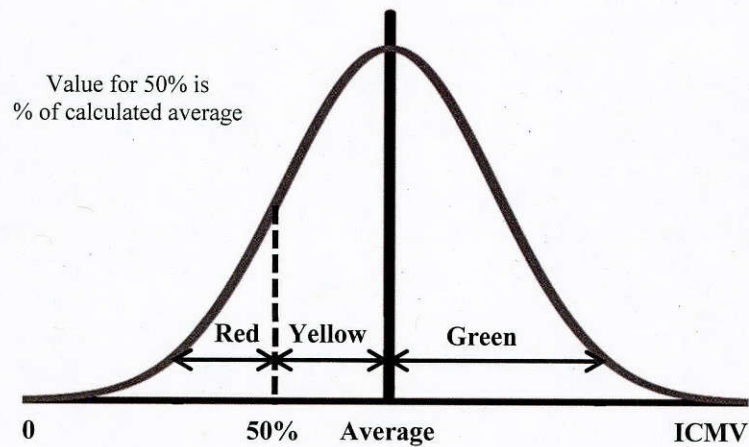
| Item No. | Data Field Name                                 | Example of Data           |
|----------|---|---------------------------|
| 1        | Roller pass number                              | 1                         |
| 2        | Direction                                       | Forward, Reverse or index |
| 3        | Roller speed (mph)                              | 3                         |
| 4        | Vibration on                                    | Yes, No, On, Off or index |
| 5        | Vibration Frequency (Hz)                        | 28.4                      |
| 6        | Vibration Amplitude (mm)                        | 1.95                      |
| 7        | Intelligent Compaction Measurement Value (ICMV) | 30.5                      |

4.6 Deliver the electronic IC data files and a hard copy of the color-coded map to the Engineer. The IC data will be color-coded using green, yellow, and red colors as shown in Table A.5 and Figure A.3. Submit compaction information and data elements using VETA<sup>®</sup>.

**Table A.5—Color-Coded Map Requirements<sup>1</sup>**

| Color   | Criteria  |
|---|---|
| Red   | Area that ICMV are less than 50% of ICTV            |
| Yellow  | Area that ICMV in the range of 50% of ICTV and ICTV |
| Green   | Area that ICMV are greater than ICTV                |
| <ol style="list-style-type: none"> <li>1. The criteria listed in this table are for producing color-coded maps using VETA<sup>®</sup> software only. Color sequence is listed from lowest to highest stiffness.</li> <li>2. The Intelligent Compaction Target Value (ICTV) is the average of the total roller ICMV data.</li> </ol> |   |

4.7 Provide displayed results to the Engineer for review upon request.



**Figure A.3. Criteria for color-coded map of ICMV data.**

---

## 5. REPORT

5.1 *IC Data Quality Control and Report.* Report the collected IC data in the specified format (see Figure A.4) upon completion of daily IC operation. The descriptive statistics of the collected ICMVs as well as the vibration amplitude and frequency shall be controlled for any discontinuity or irregular trend in the data. Plots must be scaled to be legible.

Inspector Name:  
Project Location:  
County:  
Material Type:  
Layer Type:



Date:  
Coordinate System:  
Roller Type:  
Roller Model:

**Intelligent Compaction Data Report Worksheet**

|  |  |
|--|--|
| <p><b>Color-Coded Map of ICMV</b></p>          | <p><b>Histogram of ICMV</b></p>                |
| <p><b>Histogram of Vibration Frequency</b></p> | <p><b>Histogram of Vibration Amplitude</b></p> |
| <p><b>Descriptive Statistics of ICMV</b></p>   | <p><b>Location of Less Stiff Spots</b></p>     |


**Figure A.4. IC data report worksheet.**





## Appendix B. TRAINING EVALUATION FORM USED IN WORKSHOPS

Implementation of Intelligent Compaction Technology for Improving Compaction Quality of Soil and Base in Texas  
Training Course - Texas Department of Transportation (TXDOT)



**Training Evaluation Form**

Please indicate your impressions of the items listed below.

|   | Strongly Agree        | Agree                 | Neutral               | Disagree              | Strongly Disagree     |
|---|-----------------------|-----------------------|-----------------------|-----------------------|-----------------------|
| 1. The training met my expectations.                                    | <input type="radio"/> | <input type="radio"/> | <input type="radio"/> | <input type="radio"/> | <input type="radio"/> |
| 2. I will be able to apply the knowledge learned.                       | <input type="radio"/> | <input type="radio"/> | <input type="radio"/> | <input type="radio"/> | <input type="radio"/> |
| 3. The training objectives for each topic were identified and followed. | <input type="radio"/> | <input type="radio"/> | <input type="radio"/> | <input type="radio"/> | <input type="radio"/> |
| 4. The content was organized and easy to follow.                        | <input type="radio"/> | <input type="radio"/> | <input type="radio"/> | <input type="radio"/> | <input type="radio"/> |
| 5. The materials distributed were pertinent and useful.                 | <input type="radio"/> | <input type="radio"/> | <input type="radio"/> | <input type="radio"/> | <input type="radio"/> |
| 6. The trainer was knowledgeable.                                       | <input type="radio"/> | <input type="radio"/> | <input type="radio"/> | <input type="radio"/> | <input type="radio"/> |
| 7. The quality of instruction was good.                                 | <input type="radio"/> | <input type="radio"/> | <input type="radio"/> | <input type="radio"/> | <input type="radio"/> |
| 8. The trainer met the training objectives.                             | <input type="radio"/> | <input type="radio"/> | <input type="radio"/> | <input type="radio"/> | <input type="radio"/> |
| 9. Class participation and interaction were encouraged.                 | <input type="radio"/> | <input type="radio"/> | <input type="radio"/> | <input type="radio"/> | <input type="radio"/> |
| 10. Adequate time was provided for questions and discussion.            | <input type="radio"/> | <input type="radio"/> | <input type="radio"/> | <input type="radio"/> | <input type="radio"/> |
| 11. How do you rate the training overall?                               |                       |                       |                       |                       |                       |
| Excellent   | Good                  | Average               | Poor                  | Very poor             |                       |
| <input type="radio"/>   | <input type="radio"/> | <input type="radio"/> | <input type="radio"/> | <input type="radio"/> |                       |
| 10. What aspects of the training could be improved?                     |                       |                       |                       |                       |                       |
| 11. Other comments?   |                       |                       |                       |                       |                       |

**THANK YOU FOR YOUR PARTICIPATION!**

The University of Texas at El Paso (UTEP) - Center for Transportation Infrastructure Systems (CTIS)

Figure B.1 – Training Evaluation Form



## Appendix C. LIST OF SITES

### C.1 Introduction

A training program for implementing IC technology was provided to TxDOT districts covering a wide range of information that were developed as part of Task I and designed for engineers, inspectors, contractors and roller operators. The following list shows the workshops provided to TxDOT districts.

- February 18, 2014 – Dallas and Paris, TX.
- March 20, 2015 – San Antonio and Austin, TX.
- April 29-30, 2015 – Houston and Bryan, TX.
- May 12, 2015 – Dallas, TX.
- May 21, 2015 – Dallas, TX.
- May 25-28, 2015 – Corpus Christi, San Antonio, Waco, and Austin, TX.

Intelligent Compaction was implemented in several different sites from TxDOT districts. These field evaluations consisted of different tests in multiple pavement layers. The site visits are listed below and some of them are discussed comprehensively in Appendices A through D. The test sites are the following:

- **Site B – August 12, 2015, SH 24 near Paris, TX (See Appendix A).** Field evaluation was performed on top of subgrade along a 1000-ft section.
- **Site C – August 12-13, 2015, SH 24 near Paris, TX (See Appendix A).** Field evaluation was performed along a 1000 ft-long section on top of a lime-treated subgrade.
- **Site D – September 3-4, 2015 SH 24 near Paris, TX (See Appendix A).** Field evaluation was performed along a 1000 ft-long section on top of a cement-treated base.
- **Site E – September 18, 2015, SH 24 near Paris, TX (See Appendix A).** Field evaluation was performed along a 1000 ft-long section on top of a flexible base.
- **Site F – October 5, 2015, FM 1938 in Southlake, TX.** Field evaluation was performed on road section on top of the subgrade.
- **Site G – October 6, 2015, SH 24 near Paris, TX.** Field evaluation was performed along a 1000 ft-long section on top of a lime-treated subgrade layer.
- **Site H – October 6, 2015, SH 24 near Paris, TX.** Field evaluation was performed along a section of a County Road.
- **Site I – October 6, 2015, SH 24 near Paris, TX.** Field evaluation was performed along a 1000 ft-long section of a cement-treated base layer.
- **Site J – October 6, 2015, SH 24 near Paris, TX.** Field evaluation was performed along a section on top of a recycled asphalt pavement layer.
- **Site K – October 7, 2015, US 281 near Brazos River.** Field evaluation was performed on road section on top of a subgrade.
- **Site L – February 15-18, 2016, SH 24 near Paris, TX.** Field evaluation was performed along a 1000 ft-long section on top of a cement-treated base layer.
- **Site M – April 14-15, 2016, I-35W FR NB in Fort Worth, TX (See Appendix C).** Field evaluation was performed on a 500-ft long north-bound frontage road section on top of a lime-treated subgrade layer.
- **Site N – May 5, 2016, I-35W FR NB in Fort Worth, TX.** Field evaluation was performed on a north-bound frontage road section on top of a flexible base.

- **Site O – May 13, 2016, I-35W FR NB in Fort Worth, TX (See Appendix C).** Field evaluation was performed on a 500-ft long north-bound frontage road section on top of a flexible base layer.
- **Site P – June 20, 2016, FM 1460 in Georgetown, TX (See Appendix D).** Field testing was carried out on a 250 ft-long section of a lime-treated subgrade.
- **Site Q – July 15, 2016, FM 1460 in Georgetown, TX.** Field testing was carried out on a 250 ft-long of a flexible base layer.
- **Site R – November 14-15, 2016, I-35W FR SB in Fort Worth, TX.** Field evaluation was performed along a 250-ft long south-bound frontage road section on top of a lime -treated subgrade layer.
- **Site S – February 1, 2017, US 77 NB near Victoria, TX.** Field evaluation was performed on a base layer along a 250-ft long road section.

## Appendix D. INTELLIGENT COMPACTION DATA COLLECTION

### D.1 IC Data Collection

At each construction site, the contractor's routine compaction process was followed by a proof-rolling. The goal of the proof-rolling (a.k.a., final coverage) was to evaluate the compaction uniformity through identification of soft spots and ensuring the complete coverage of the compacted section. Further analyses of the collected IC data during the proof-rolling were carried out on the IC data.

To further evaluate the vibration characteristics of the IC systems, a data acquisition system developed by UTEP research team was also employed. A schematic of the UTEP's validation system is in Figure E.1. The system consisted of one or two accelerometers mounted inside the drums to capture the vibration of the drum, a data acquisition system, a GPS antenna/ receiver, a power supply and a laptop computer to monitor the data collection process. Figure D.2 illustrates the mounted accelerometer for validation purposes as well as the existing IC accelerometer that could be either a part of an OEM system or an IC retrofit kit.

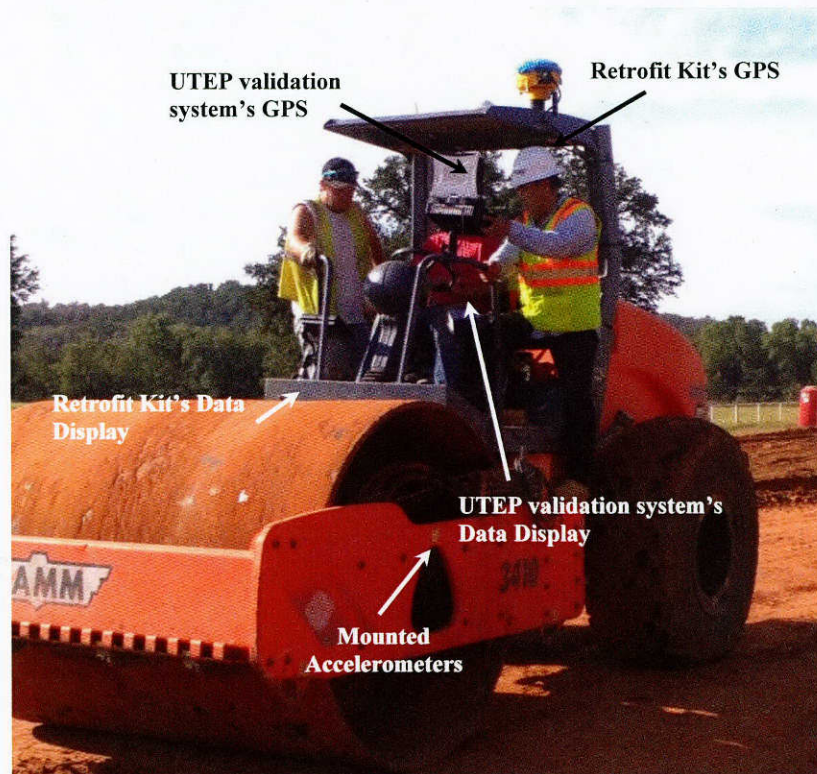


Figure D.1 - Schematic of UTEP IC Validation System.

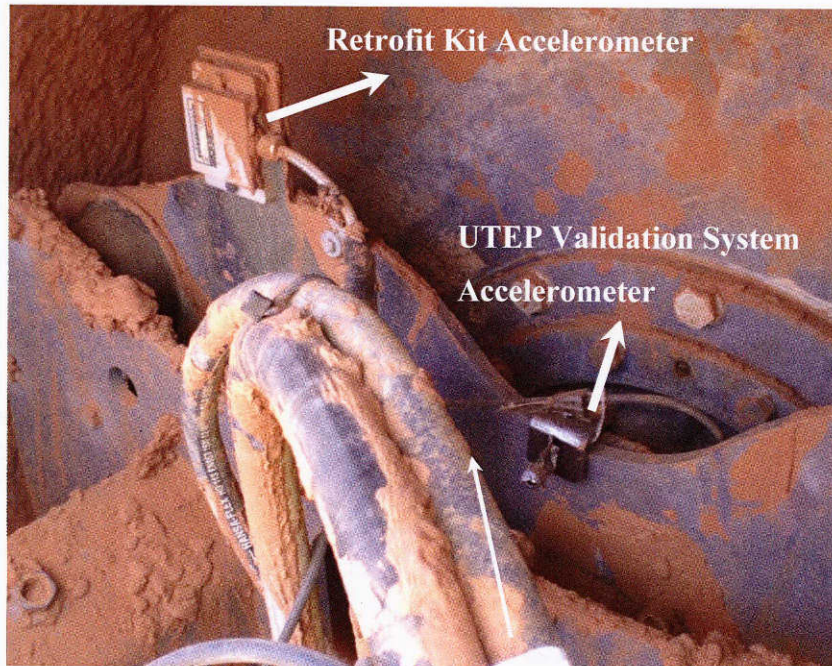


Figure D.2 - Mounted Accelerometers from IC Retrofit Kit and UTEP Validation System.

Figure D.3 illustrates typical vibration data from mounted accelerometers during data collection. The collected vibration data from the validation system in the time domain were converted to the frequency domain a Fast-Fourier Transform (FFT) algorithm to obtain the roller vibration parameters such as the vibration frequency and its amplitude. In some occasions during this project, the research team installed two accelerometers inside the drum to capture additional vibration data.

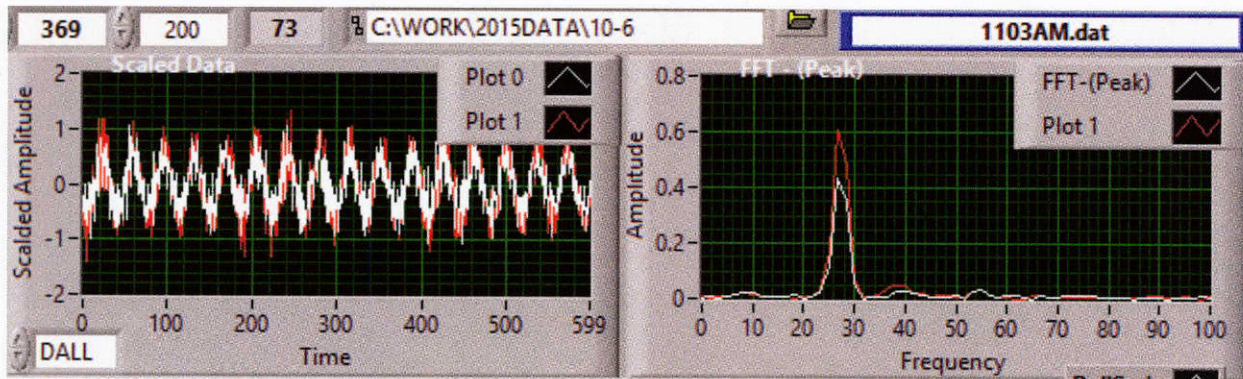
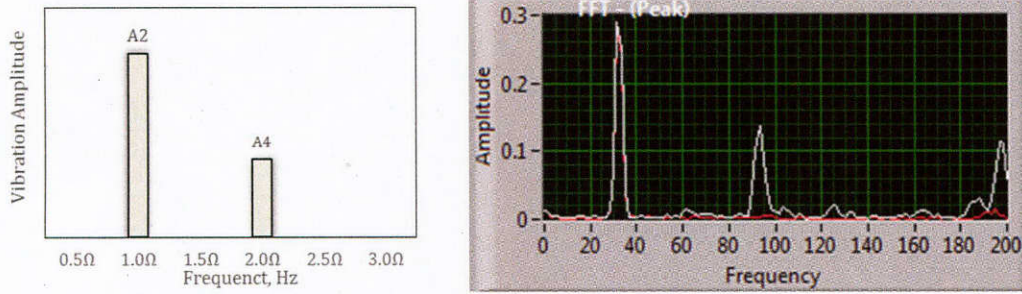


Figure D.3 - Typical Vibration Data Collected by UTEP Mounted Accelerometers.

The intelligent compaction meter value (ICMV) parameter could be regenerated from the frequency-domain vibration data. The calculated ICMVs were then compared to the ICMVs collected by the retrofit/OEM IC system to validate the results of the IC systems. Figure E.4 shows the application of peak frequency and first harmonic frequency ( $A_2$  and  $A_4$  in Figure E.4) to calculate the compaction meter value (CMV). The CMV was calculated as:

$$CMV = C \times \left(\frac{A_4}{A_2}\right) \quad (1)$$

where  $C$  is a constant defined by the vendor (typically 300).



**Figure D.4 - Extraction of Vibration Frequency Data to Calculate CMV.**

### E.2 IC Data Management

Most of the IC system vendors provide an online data management tool to save and manage the collected IC data during a construction process. However, these data management tools provide the user with the option to export the IC data in comma separated variables (csv) format for further analysis. Table D.1 summarizes the data management tools and file formats for three IC vendors. The Trimble® and Topcon® IC retrofit kits support the same file formats as in Table D.1. Since most of the IC rollers employed in this project used the Trimble® system, the Visionlink® online data management tool was employed to extract and export the collected IC data. For each project, a unique username and password was assigned to the TxDOT engineer and the research team to access the site-specific IC data.

**Table D.1 IC Data Formats and Management Tools**

| Roller Vendor                | HAMM                      | CAT and Trimble | SAKAI             |
|------------------------------|---------------------------|-----------------|-------------------|
| Native Data Format           | *.hcqx                    | *.tag           | *.ml3             |
| Exported Gridded Data Format | *_amd.vexp,<br>*_pmd.vexp | *.csv           | *.pln and *.plns  |
| Software                     | HCQ                       | VisionLink®     | TOPCON SiteLink3D |





## Appendix E. GPS CALIBRATION PROCESS

### E.1 GPS Calibration Process

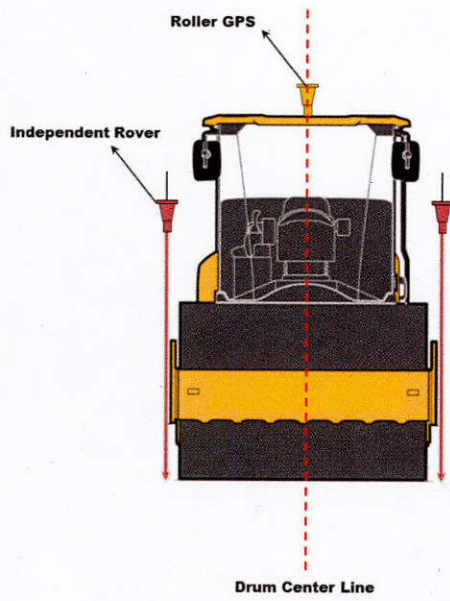
Since GPS receivers are usually installed in the roller cabin, both the OEM and retrofit IC systems apply an offset to the collected GPS positions to correct the coordinate for the center of the drum to generate the IC data maps. To meet the survey grade precision, the GPS readings from the IC systems needed to be calibrated with signals from a land-based GPS base station or virtual reference stations. The process of GPS calibration is shown in Figures E.1. The IC roller moves slowly to a designated position to allow the system to stabilize. Once the roller's position becomes static, the GPS coordinates reading, which is associated with the center of the drum, is recorded.



**Figure E.1 - Mapping Test Section Using Local Base Station.**

The coordinates of both sides of the drum are then recorded using a handheld survey-grade GPS rover that was previously synched with the local base station, as shown in Figure E.2. The coordinates of the drum center could be interpolated from the coordinates of the two sides of the drum. The coordinates reported by the OEM/retrofit IC system are then compared with the coordinates interpolated using the coordinates from handheld rover. If necessary, the OEM/retrofit systems' coordinates are transformed to match the estimated coordinate system. The tolerance of the differences is typically 12 in. in the northing and easting directions, as recommended in the FHWA generic IC specifications. Such validation process is strongly recommended before starting the IC data collection process to avoid the data shifts or erroneous setup.

The Universal Transverse Mercator (UTM) coordinate system was typically used to locate and map the test section. The GPS systems on the IC rollers could either use a local or virtual base station. The Virtual Reference System (VRS) in Texas is usually used to calibrate the IC GPS systems when a local base station is not available at the construction site. The VRS connection sometimes generated some difficulties prior to the initiation of the IC data collection. Such concerns are discussed in Chapter 5.



**Figure E.2 - GPS Calibration Process.**

## Appendix F. FIELD EVALUATION AT PARIS DISTRICT, STATE HIGHWAY (SH) 24

### F.1 Introduction

This test section was a part of the expansion of SH 24 near Cooper, Texas in Paris District. The research team assisted the project staff and the contractor representatives from August 12, 2015 to September 18, 2015. This observation involved a number of field visits by the research team.

Figure F.1 shows an aerial view of the location of test section alongside with the stationing map. This figure also illustrates the location of test grid where spot tests were performed by the research team.

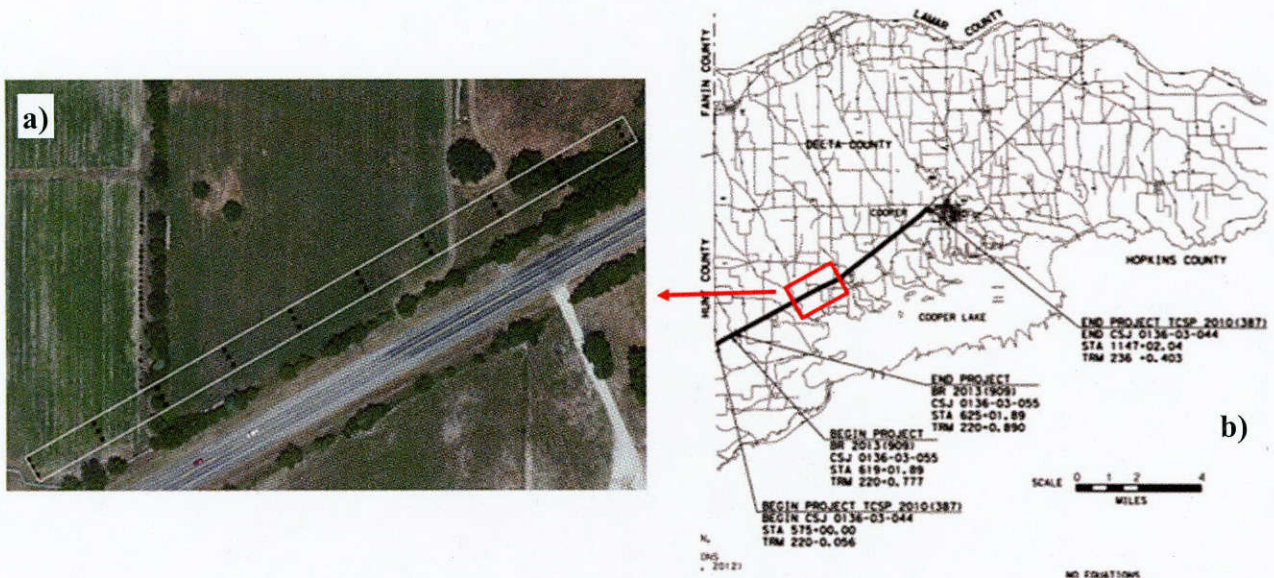
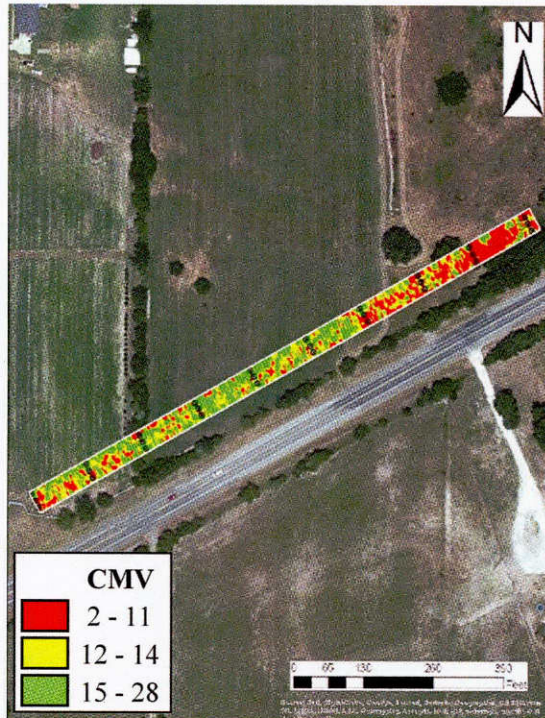


Figure F.1 - (a) Aerial View and (b) Stationing Map of the Test Section along State Highway SH 24.

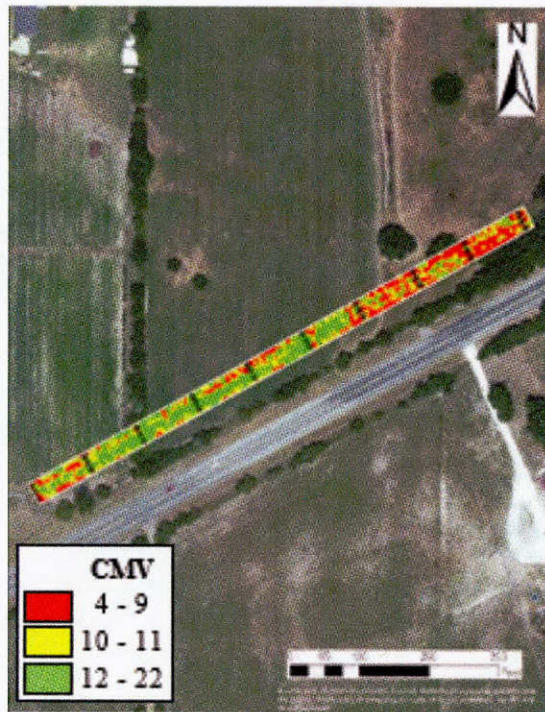
### F.2 SH 24 Subgrade

The existing subgrade layer was pre-mapped using a pad-foot CAT roller equipped with a Trimble® IC retrofit kit. The first phase of the construction work was involved with stabilizing the subgrade soil using hydrated lime. The designed thickness of the lime treated subgrade (LTS) layer was 8 in. The LTS layer was placed, compacted, and mapped using the IC roller on August 12, 2015.

Figure F.2 and F.3 illustrate the spatial distributions of the CMVs collected using the pad-foot roller during the pre-mapping of the existing layer and mapping of the LTS layer, respectively. The location of the less stiff areas on both maps are comparable. The histograms of the pre-mapped and mapped CMVs are summarized in Figure F.4 and F.5. The maximum CMVs are 28 for the pre-mapped layer and 22 for the mapped layer. The coefficients of variation (COVs) of the collected CMVs are around 48% for the LTS layer and 49% for the existing layer.



**Figure F.2 - Spatial Distribution of CMV Data Collected by IC Retrofit System during Pre-Mapping of Existing Subgrade Layer.**



**Figure F.3 - Spatial Distribution of CMV Data Collected by IC Retrofit System during Mapping of Compacted LTS Layer.**

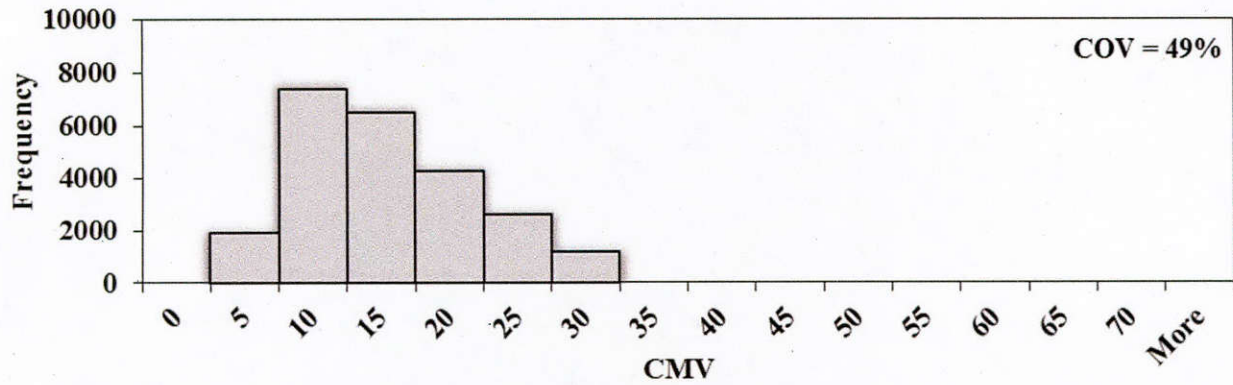


Figure F.4 - Distribution of CMV Data during Pre-Mapping of Existing Subgrade Layer.

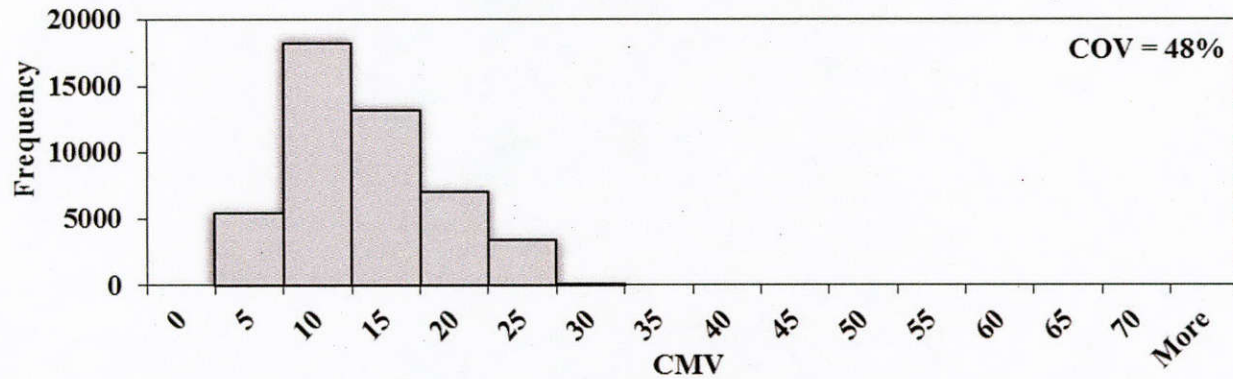
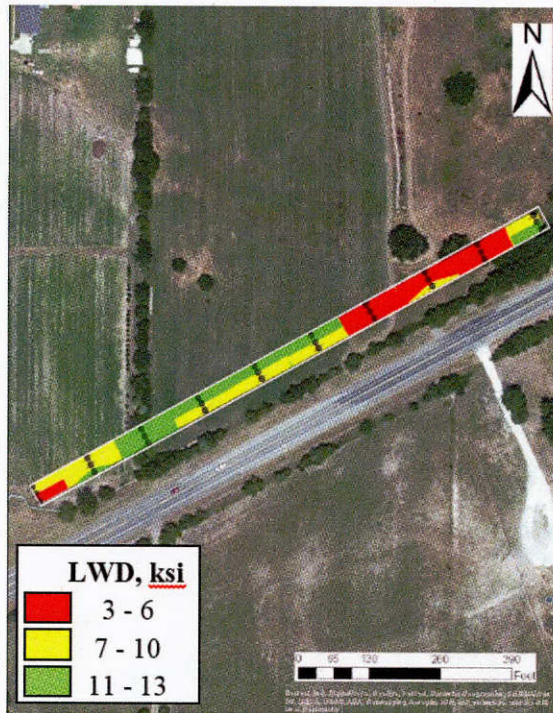


Figure F.5 - Distribution of CMV Data during Mapping of LTS Layer.

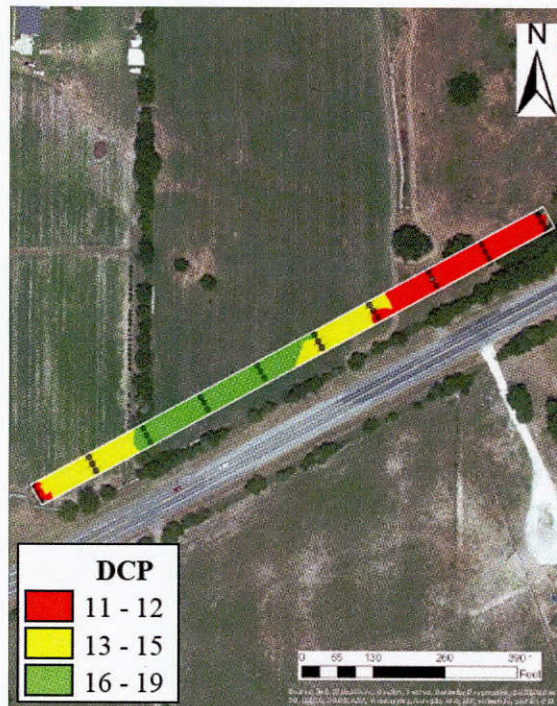
Once compaction and mapping of the lime-treated subgrade was completed, spot testing with the LWD, DCP and NDG was performed on the compacted layer. A total of 30 spot tests per device were conducted within the test section. The collected spot test data were imported into ArcGIS software to generate the color-coded geospatial distribution maps. The Empirical Bayesian Kriging spatial interpolation algorithm was employed for the geospatial interpolation process. The advantage of this method as compared to the classical Kriging algorithm is that it uses semivariograms estimated from the actual data followed by generation of simulated data from the initial semivariograms. A new semivariogram model is then generated from the simulated data. The weight of the latest semivariogram is estimated using the Bayes rule which indicates the likelihood of the observed data being generated from the semivariogram model. The Quantile Classification method was employed to classify the data into three colors. This method distributes a set of values into groups that contain the equal numbers of values.

Figure F.6 illustrates the spatial distribution of the LWD modulus on top of the compacted LTS layer. The LWD moduli varied from 1 ksi to 14 ksi with an average of 8 ksi and a COV of 45%. The north-eastern part of the test section showed lower LWD moduli which is in agreement with the CMV data in Figures F.2 and F.3.

Figure F.7 summarizes the DCP results on the compacted LTS layer. The estimated DCP moduli ranged from 6 ksi to 25 ksi with an average of 14 ksi and a COV of 31%. The same less-stiff area is recognizable in this figure as compared to the LWD and CMV data. The DCP is a layer specific device since it reflects the properties of the layer of interest as compared to LWD that reports a composite modulus of the underlying layers.



**Figure F.6 - Spatial Variation of LWD Modulus on Compacted LTS Layer.**



**Figure F.7 - Spatial Variation of DCP Modulus on Compacted LTS Layer.**

The NDG moisture content and dry density variations are depicted in Figures F.8 and F.9. The NDG moisture contents varied from 15% to 22% with an average of 19% and a COV of 11%, while the dry densities were in the range of 90 pcf to 104 pcf with an average of 98 pcf and a COV of 4%. Strong relationships could not be observed among the moisture content, density with the LWD or DCP moduli or CMVs.

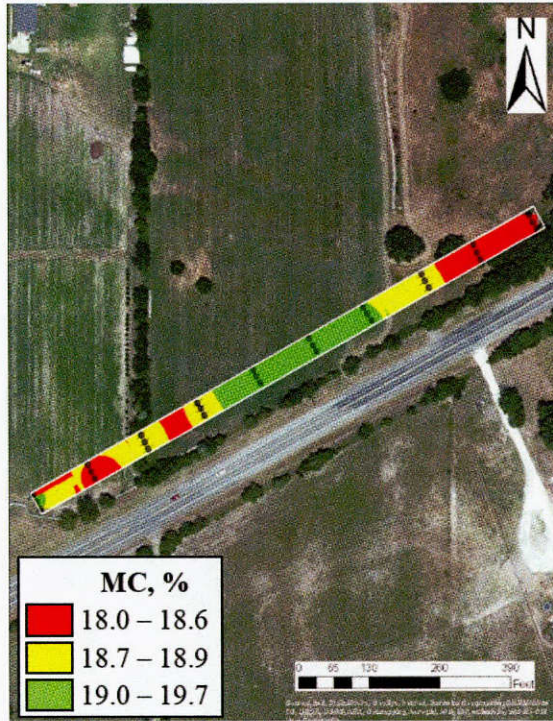


Figure F.8 - Spatial Variation of NDG Moisture Content on Compacted LTS Layer.

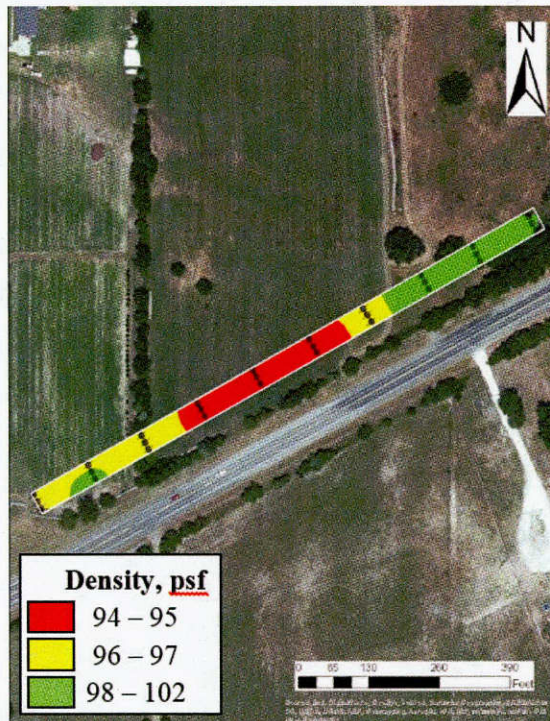


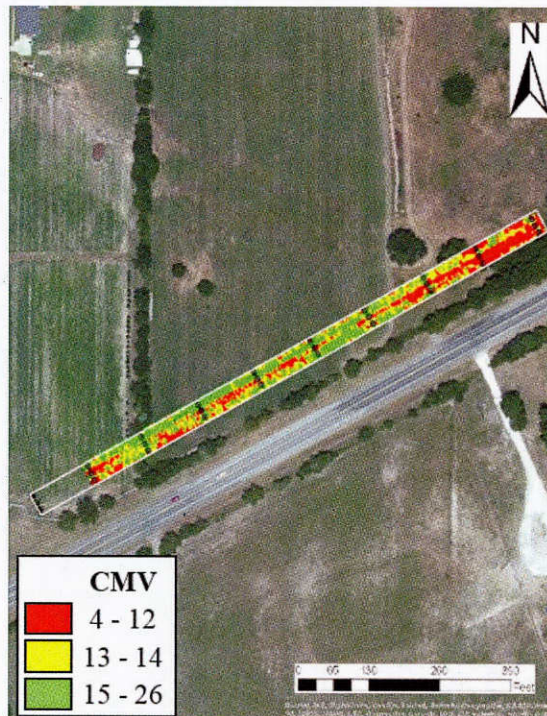
Figure F.9 - Spatial Variation of NDG Dry Density on Compacted LTS Layer.

### F.3 SH 24 Cement-Treated Base (CTB)

The next construction phase consisted of stabilizing the base materials with cement. The nominal thickness of the cement-treated base (CTB) layer was 8 in. The CTB layer was placed, compacted and mapped using the padfoot IC roller on September 3<sup>rd</sup> and 4<sup>th</sup>, 2015. Due to some construction constraints, a small portion of the designated test section was not covered with the CTB layer, and consequently, 27 spot tests were conducted in this phase.

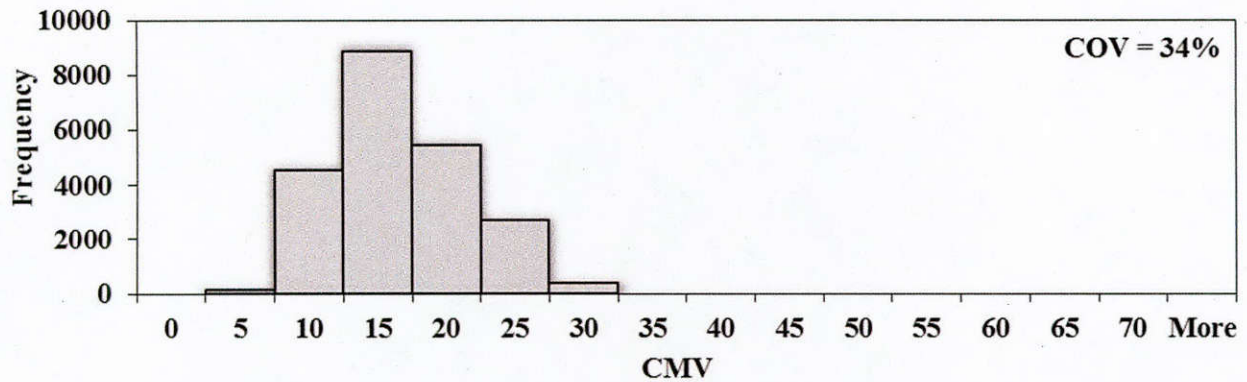
Figure F.10 illustrates the spatial distribution of the CMV data during the mapping of the compacted CTB layer. The blank area in the south-western end of the test section corresponds to the area that was not covered with CTB. Compared to the CMV data collected on the existing subgrade and LTS in Figures F.2 and F.3, the same less-stiff area could be recognized after mapping the compacted CTB layer.

The histogram of the collected CMV data on the CTB is depicted in Figure F.11. The average CMV is quite higher than the LTS and existing subgrade layers (see Figures F.4 and F.5) reflecting the higher stiffness of CTB. The COV of the collected CMV data is reduced to 34% for the CTB which represents a more uniform pavement cross section.



**Figure F.8 - Spatial Distribution of CMV Data from IC Retrofit System during Mapping of Compacted CTB Layer.**

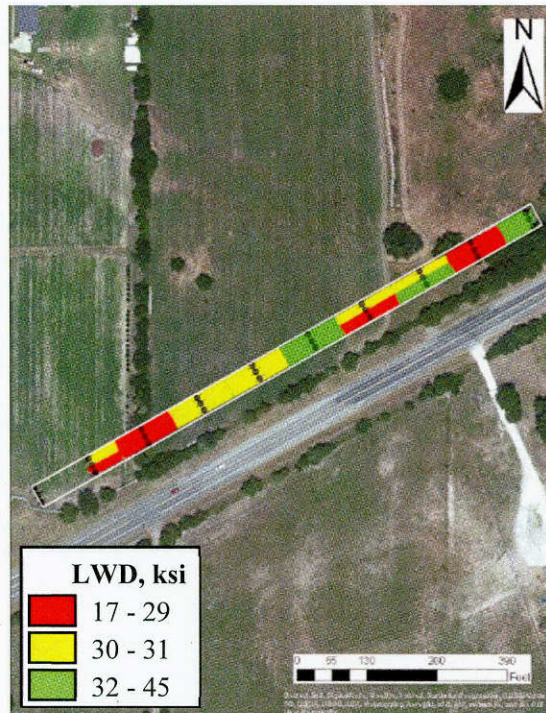




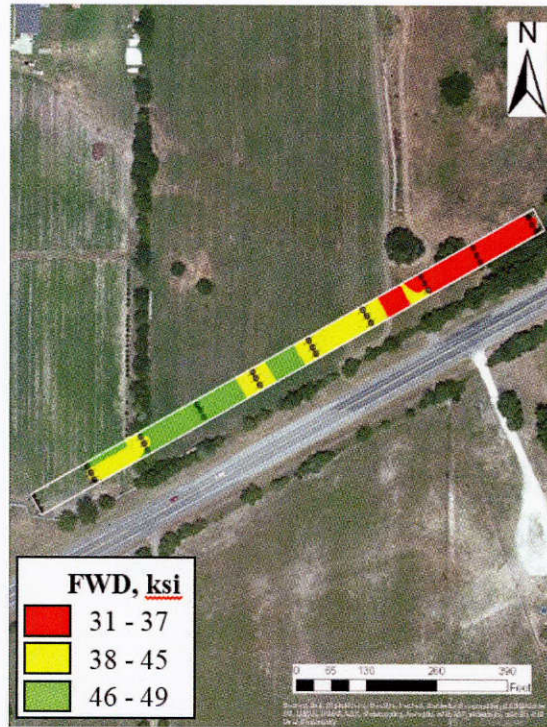
**Figure F.9 - Distribution of CMV Data during Mapping of Compacted CTB Layer.**

Once the mapping process was complete, the spot tests were conducted on top of the compacted CTB. The LWD moduli varied from 4 ksi to 48 ksi with an average of 29 ksi and COV of 44% (see Figure F.12). Due to extreme rigidity of the CTB materials, the DCP and NDG tests were conducted only at a few spots within the test section. Since the collected data was not sufficient to generate the color-coded spatial distribution maps, an FWD was employed to perform the spot tests. Figure F.13 summarizes the spatial distribution of the FWD moduli. The estimated FWD moduli varied from 25 ksi to 693 ksi with an average of 261 ksi and COV of 79%.

Although the LWD results do not reflect a clear correlation with the CMV data in Figure F.10, the FWD data show more comparable results to CMV in terms of the identification of the less-stiff areas.



**Figure F.10 - Spatial Variation of LWD Modulus on Compacted CTB Layer.**



**Figure F.11 - Spatial Variation of FWD Modulus on Compacted CTB Layer.**

#### **F.4 SH 24 Flexible Base**

The last phase of the construction consisted of placing and compacting untreated (flexible) base materials. The design thickness of the flexible base (FB) layer was 6 in. The same area that was mapped and tested with the CTB was also mapped and tested for the FB materials.

Figure F.14 illustrates the spatial distribution of the CMV data during the mapping of the compacted FB layer. There is a noticeable change in the location of the less-stiff areas in this layer as compared to previous layers. The histogram of the CMV distribution depicted in Figure F.15 exhibits a considerable change in the trend of the collected CMV data. The average CMV seems to be higher than the previous layers and the COV is reduced to 27%. This change in the pattern of the collected CMVs is mostly due to the influence depth of the IC roller and the fact that CMV is an estimation of a composite stiffness of several layers.

The LWD and FWD tests were conducted on the spot locations within the test section. The LWD moduli varies from 9 ksi to 16 ksi, with an average of 12 ksi and COV of 15% (see Figure F.16). Figure F.17 summarizes the spatial distribution of the FWD data. The FWD moduli changed from 22 ksi to 55 ksi, with an average of 38 ksi and COV of 21%. Again, since DCP and NDG tests were only feasible on few locations, their distribution maps are not available.

Comparing the LWD and FWD results with the collected CMV data during the mapping of the FB layers, there is a noticeable similarity between the trend of interpolated spot test data and CMV results in terms of identification of less stiff spots.

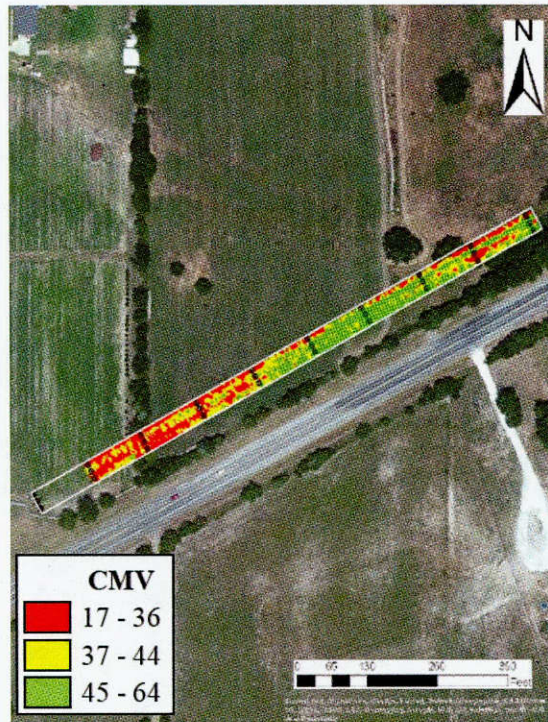


Figure F.12 - Spatial Distribution of CMV Data from IC Retrofit System during Mapping of Compacted FB Layer.

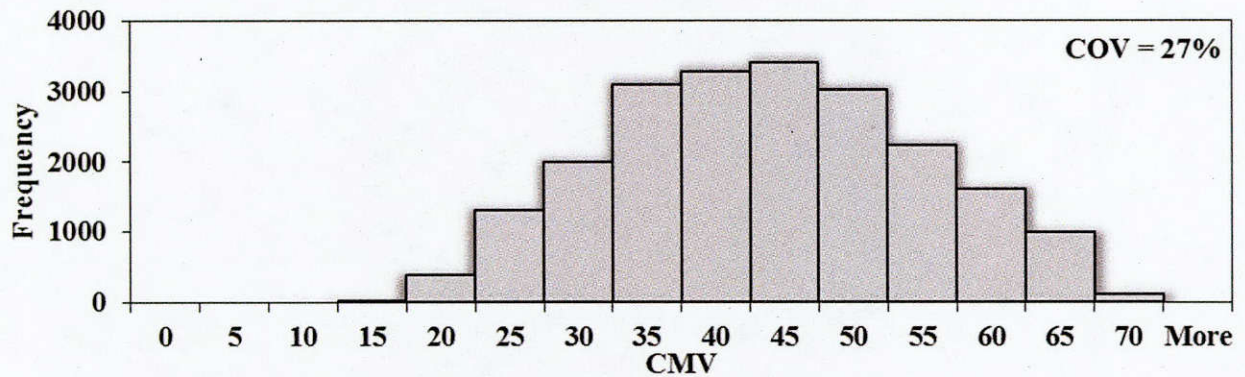


Figure F.13 - Distribution of CMV Data during Mapping of Compacted FB Layer.

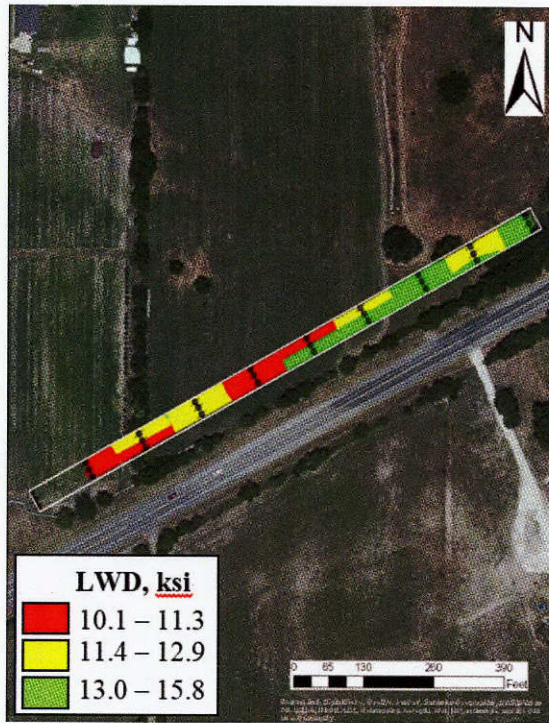


Figure F.14 - Spatial Variation of LWD Modulus on Compacted FB Layer.

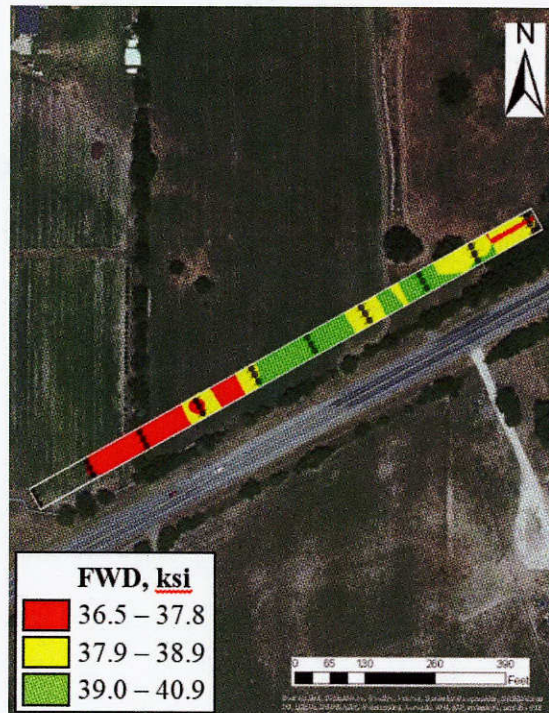


Figure F.15 - Spatial Variation of FWD Modulus on Compacted FB Layer.

## Appendix G. FIELD EVALUATION AT FORT WORTH, IH 35W HIGHWAY

### G.1 Introduction

Field evaluation was performed on a north-bound frontage road section from Interstate IH 35W in Fort Worth, Texas, where reconstruction of the road was taking place. Figure G.1 shows an aerial view of the of the test section alongside a map with the location of the test section within the Fort Worth area.

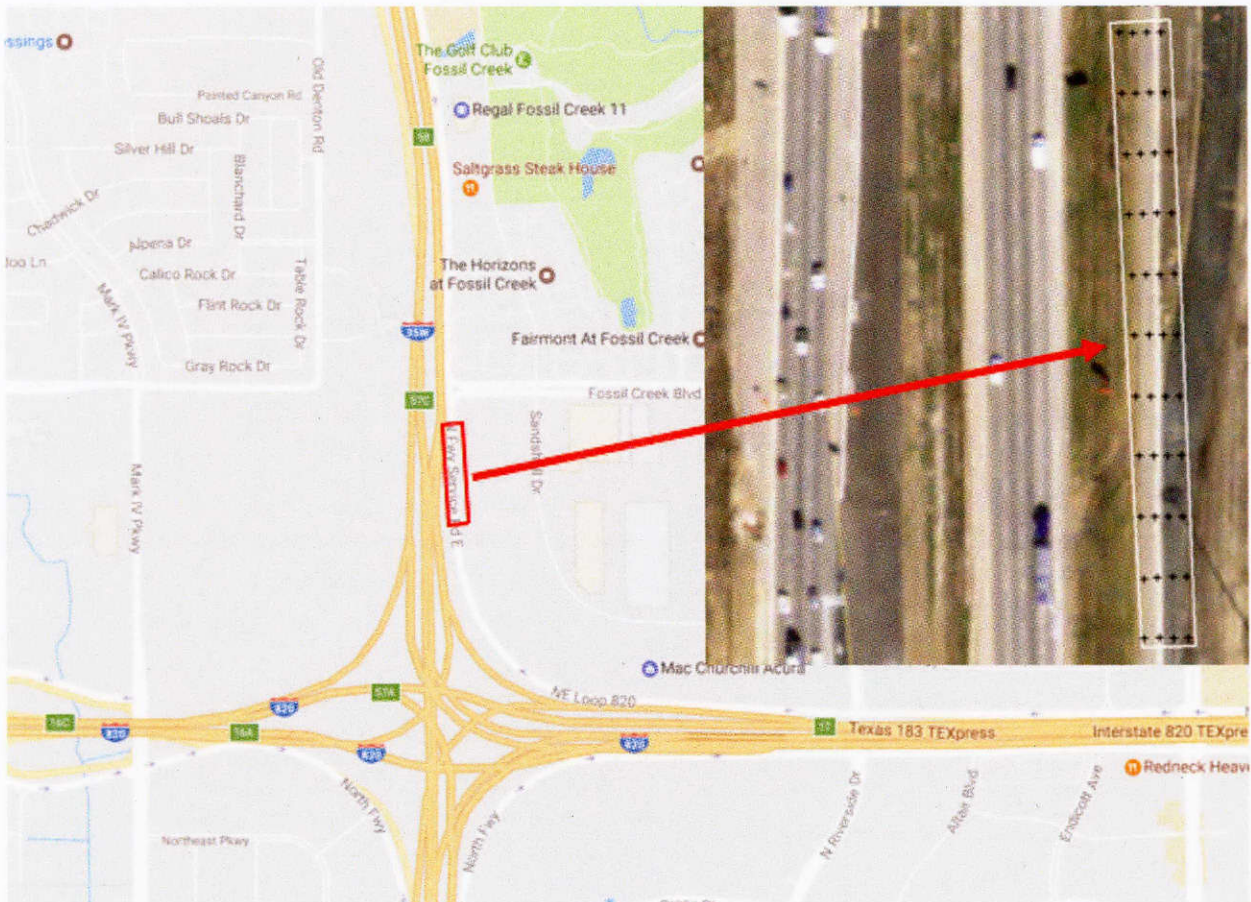


Figure G.1 - Location of Field Evaluation Site on I-35 in Fort Worth, TX.

Two layers were evaluated for this study. The first layer consisted of a lime-treated subgrade (LTS) with a design thickness of 36 in. Compaction, mapping, and field evaluation of the LTS took place on April 14, 2016. The second layer evaluated in this section was a flexible base with design thickness of 12 in. Field evaluation for the flexible base was carried out on May 13, 2016.

### G.2 Field Testing Program

Spot testing was carried out along a 500 ft.-long and 27 ft. wide section. A grid consisting of 44 points divided in 4 columns of 11 points each was selected for the location of the spot tests. The grid was designed with a spacing of 50-ft between each of the 11 points, and a spacing of 9-ft between each column as shown in Figure G.2a.

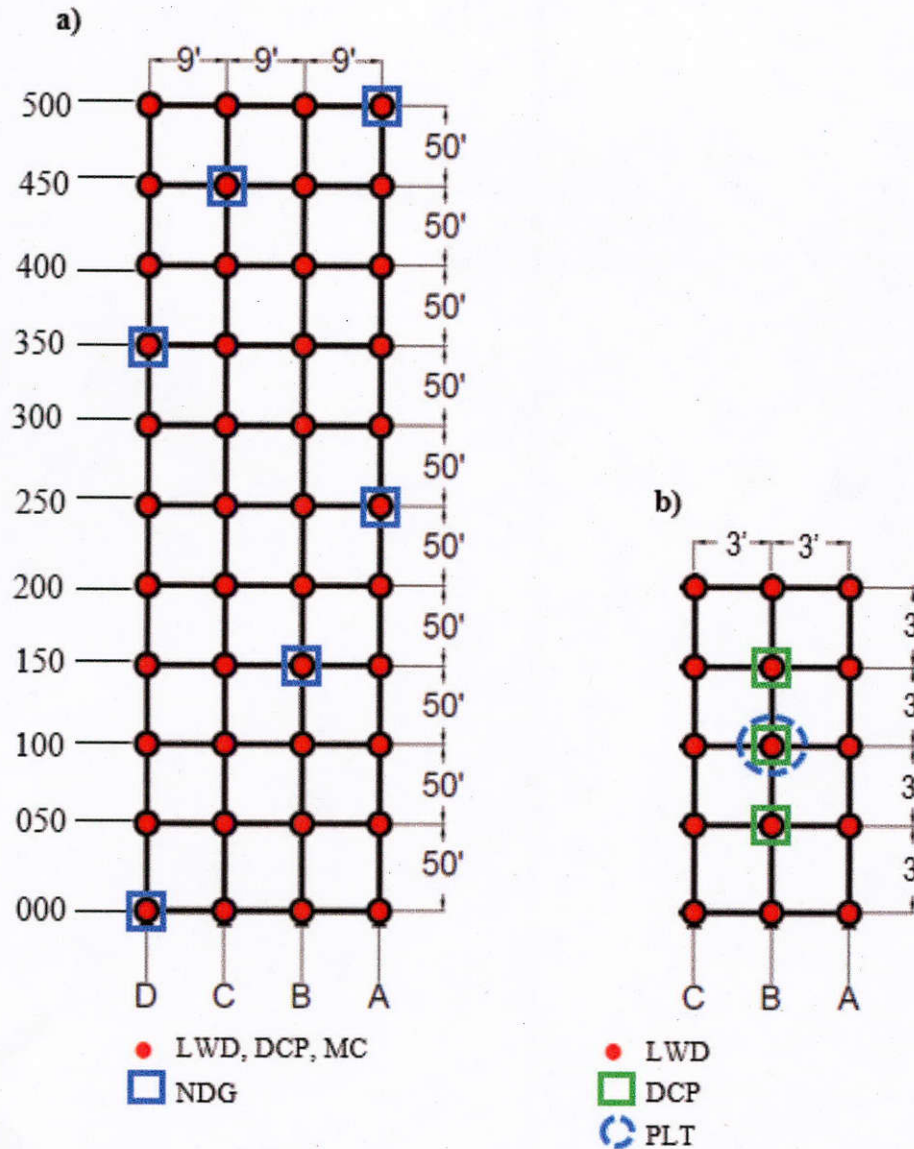


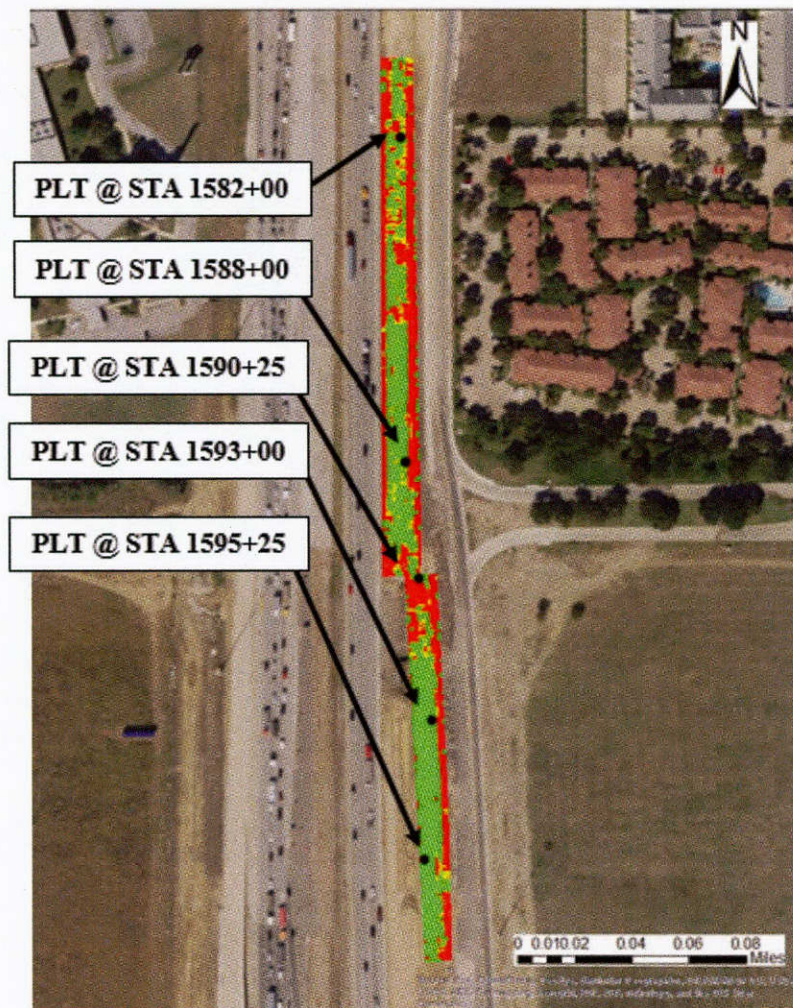
Figure G.2 a) Schematic of the Typical Test Section and Location of Spot Tests and b) Diagram of the Testing Area around the PLT Locations.

**Lime Treated Subgrade Layer:** The following tests were performed on the test section:

- **Light-Weight Deflectometer (LWD)** LWD testing was performed on all 44 points on the grid. Each spot test consisted of two measurements of the surface displacement that were averaged. In those cases where the displacement measurements didn't fall in proximity to each other a third LWD measurement was recorded. In addition to the spot testing on the grid, LWD testing was also performed in 15 spots surrounding each location where the Plate Load Tests were done. The grid formed by these 15 spots is shown in Figure G.2b.
- **Dynamic Cone Penetrometer (DCP)** The Lime Treated Subgrade Layer was tested with the DCP in all 44 points from the grid. On average it took a total of 42 blows per spot to

penetrate 24 in. of the LTS. It was also done three times around the location of the spots where the Plate Load Tests was conducted.

- **Nuclear Density Gauge (NDG)** NDG readings were obtained from 6 different spots selected by the contractor. The location of these spots are shown in Figure G.2a.
- **Plate Load Test (PLT)** PLT was performed on 5 different spots throughout the Subgrade Layer. The locations of these spots were selected based on the readings of the IC roller. Points were chosen by TxDOT personnel based on the roller readings, i.e. mapping of CMVs, provided by the contractor. Spots were selected based on red and yellow areas on the mapping, allegedly indicating less stiff compacted areas. The Plate Load Tests locations are shown in Figure G.3.
- **Moisture Content (MC)** Samples from the 44 gridded points shown in Figure G.2a were collected to measure the moisture content. Samples were taken from the Lime Treated Subgrade and properly stored and labeled for laboratory testing.



- Figure G.3 Aerial View of the PLT Locations.

### G.3 Lime-Treated Subgrade

The lime-treated subgrade layer was mapped using a smooth CAT roller equipped with a Trimble® IC retrofit kit. The first phase of the construction work was involved with stabilizing the subgrade soil using hydrated lime. The spatial distribution of the CMVs collected during the mapping of the LTS layer is shown in Figure G.4a. Figure G.4b shows the spatial distribution of averaged buffered CMVs when the entire section was divided into 44 rectangular areas measuring 9 ft × 50 ft. The location of the less stiff areas on both maps are comparable. The histogram of the mapped CMVs is summarized in Figure G.5. The maximum CMV is around 75 for the spatial distribution of the raw data and 58 for the averaged data. The coefficient of variation (COV) of the raw collected CMVs is 49% for the LTS layer. COV of the mapped CMV data decreased to 27%, as shown in Figure G.4a, due to the use of a spline spatial interpolation algorithm for the mapping process.

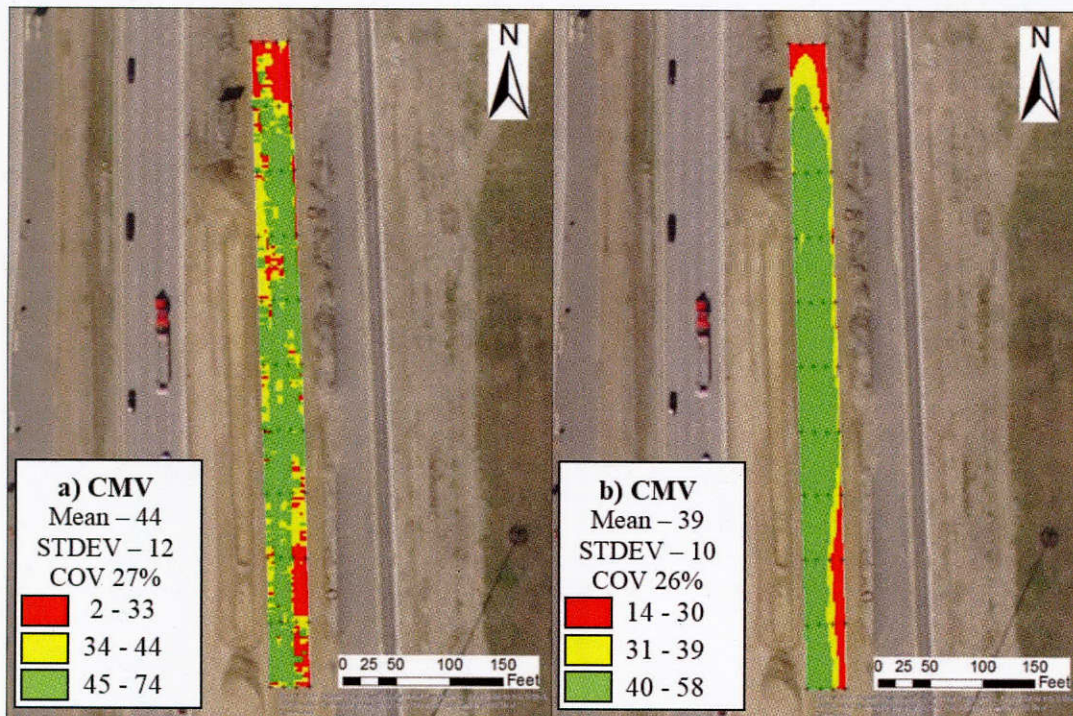
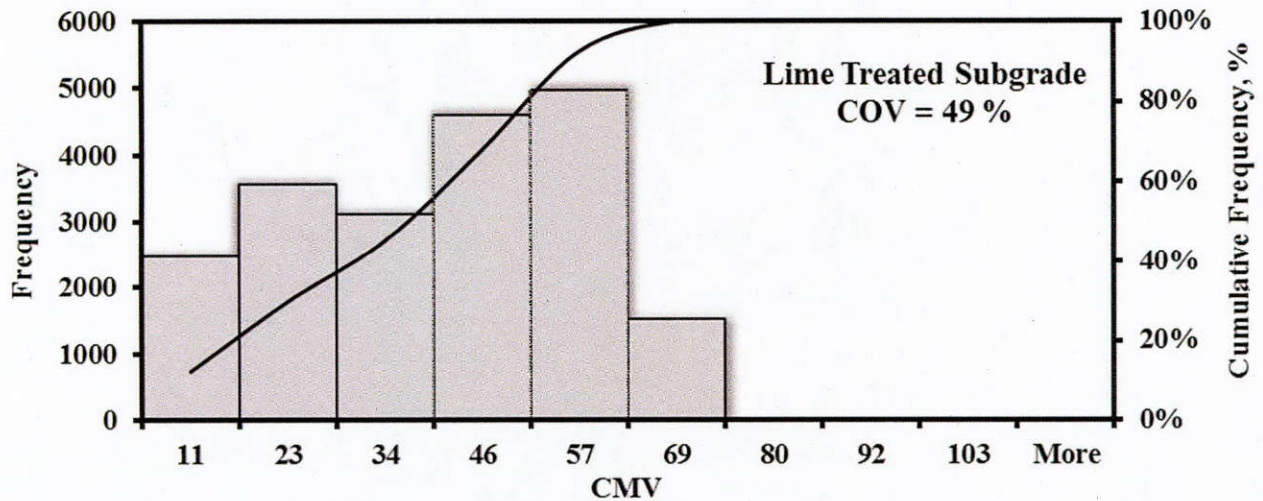


Figure G.4 - Spatial Distribution of (a) Raw and (b) Square Buffered CMV Data Collected by IC Roller during Proof-Rolling of LTS Layer.





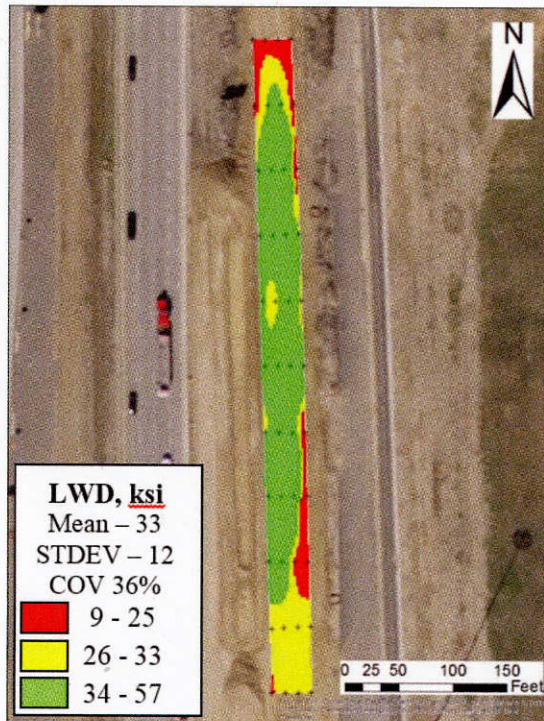
**Figure G.5 - Distribution of CMV Data Collected by IC Roller during Proof-Rolling of LTS Layer.**

Once the compaction and mapping of the lime-treated subgrade was completed, field testing was performed with the LWD, NDG, PLT and DCP on the compacted layer at 44 points along the test section. These points were taken 50 ft apart in the longitudinal direction and 9 ft apart transversally, as shown in G.2a. In addition, samples were collected for determining the moisture content of the geomaterial. The collected spot test data were imported into ArcGIS software to generate color-coded geospatial distribution maps. The spline spatial interpolation algorithm was employed for the process of spatial interpolation. The classification method for the color criterion was based on the mean as obtained for all the different spot test measurements as shown in Table G.1.

**Table G.1. Criterion for Color-Coded Maps**

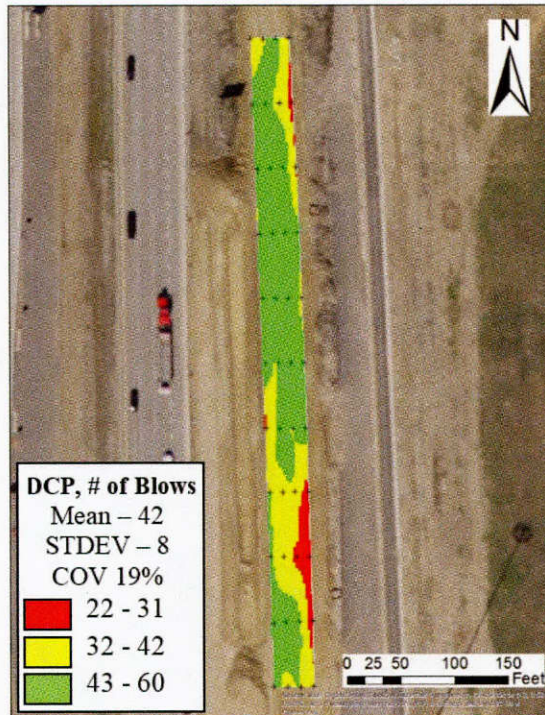
| Color  | Criterion        |
|--------|------------------|
| Red    | < 0.75 Mean      |
| Yellow | 0.75 Mean - Mean |
| Green  | > Mean           |

Figure G.6 illustrates the spatial distribution of the LWD modulus on top of the compacted LTS layer. The LWD moduli varied from 9 ksi to 57 ksi with an average of 33 ksi and a COV of 36%. The northern and southeastern areas of the test section showed lower LWD moduli which is in agreement with the CMV data in Figures G.4a and G.4b.



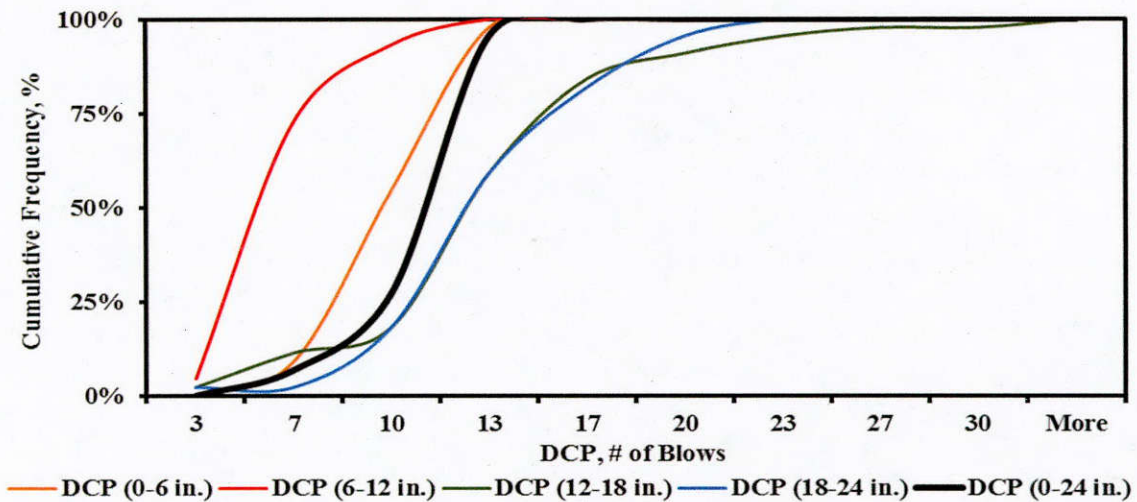
**Figure G.6 – Spatial Distribution of LWD Modulus on LTS Layer.**

Figure G.7 summarizes the DCP results on the compacted LTS layer. The estimated DCP number of blows required to penetrate to a depth of 24 in. ranged from 22 blows to 60 blows with an average of 42 blows and a COV of 19%. The DCP is a layer specific device since it reflects the properties of the layer of interest as compared to LWD that reports a composite modulus of the underlying layers. Similar to LWD, the southeastern parts required fewer DCP blows than the mid-section, where the LTS is stiffer. This is in agreement with the LWD geospatial distribution shown in Figure H.6 and bears resemblance to the CMV geospatial distribution shown in Figure G.4b.



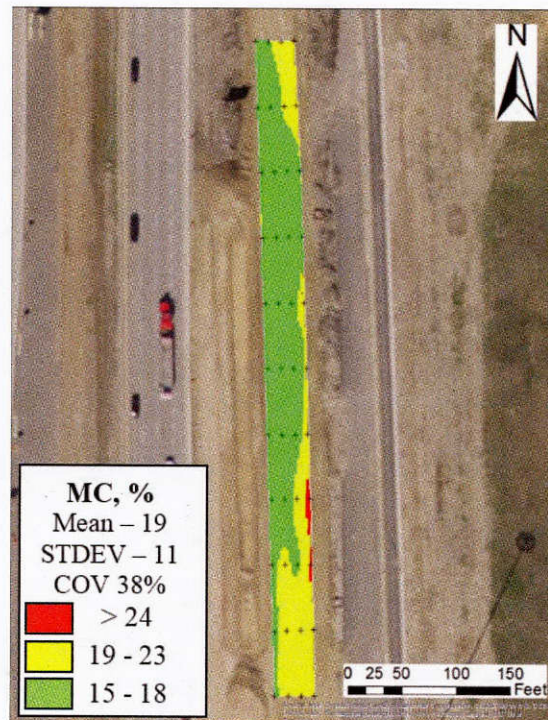
**Figure G.7 – Spatial Distribution of Number of DCP Blows on LTS Layer.**

The cumulative distribution of the number of DCP blows is shown in Figure G.8. The cumulative distribution was calculated by adding the total number of blows to penetrate 24 in. and divided by 4 layers. The distribution indicates the lower 12 in. are stiffer requiring more blows to penetrate through them.



**Figure G.8 – Cumulative Distribution of Number of DCP Blows in LTS Layer.**

Figure G.9 illustrates the spatial distribution of the moisture content found at the surface of the LTS layer. The moisture content varied from 15% to 24% with an average of 19% and a COV of 38%. Throughout the test section the areas with lower moisture content are in agreement with the stiffer areas found in the CMV data.



**Figure G.9 – Spatial Distribution of Moisture Content of LTS Layer.**

A comparison between the LWD modulus and the CMV data at different stations is illustrated in Figure G.10a. An LWD target modulus of 32 ksi was determined using a multi-layer linear elastic analysis and included in Figure H.10a. Both data sets show similar trends. The center part of the test section showed higher LWD modulus and CMVs than the northern and southern ends of the test section. In addition, average LWD moduli in the center part of the section were greater than the LWD target modulus, while the values reported at the ends of the test section were lower. A similar comparison using the number of DCP blows to penetrate 24 in. in depth and CMV data is shown in Figure G.10b. Though not as manifest as with LWD, some similarity in the trend may be seen between the number of DCP blows and CMV.

Plate load tests (PLT) were performed at five different locations as shown in Figure G.3. The locations of these tests were selected by TxDOT personnel based on the mapping of CMVs, provided by the contractor. 15 LWD measurements were taken in a 12 ft×6 ft gridded area around the PLT test spot, as shown in Figure G.2b. These measurements were mapped using the same criterion shown in Table G.1. The geospatial variations of the LWD moduli around the PLT locations are shown in Figure G.11. The PLT moduli varied from 10 ksi to 43 ksi with an average of 28 ksi. Descriptive statistics of LWD moduli for each rectangular buffer around the PLT location are included next to the mapped LWD moduli. The mapping of LWD moduli shows considerable variation around the spot tests. The maximum COV of LWD moduli found was 40% at station 1590+25 as shown in Figure G.11c.

#### **G.4 Flexible Base**

The next phase of the construction consisted of placing and compacting flexible base materials. The design thickness of the flexible base (FB) layer was 12 in. The tested area for the flexible base was the same area evaluated for LTS.

Figure G.12a illustrates the spatial distribution of the CMV data during the mapping of the compacted base layer. Figure G.12b shows the spatial distribution of averaged buffered CMVs when the entire section was divided into 44 rectangular buffer areas measuring 9 ft × 50 ft. The histogram of the CMV distribution depicted in Figure G.13 exhibits a considerable change in the trend of the collected CMV data. The average CMV seems to be higher than the previous layer and the COV is reduced to 17%.

The LWD tests were conducted on the spot locations within the test section. The LWD moduli varies from 11 ksi to 57 ksi, with an average of 26 ksi and COV of 35% (see Figure G.14). The areas of the test section showing higher LWD moduli are in accordance with the CMV data shown in Figures G.12a and G.12b.

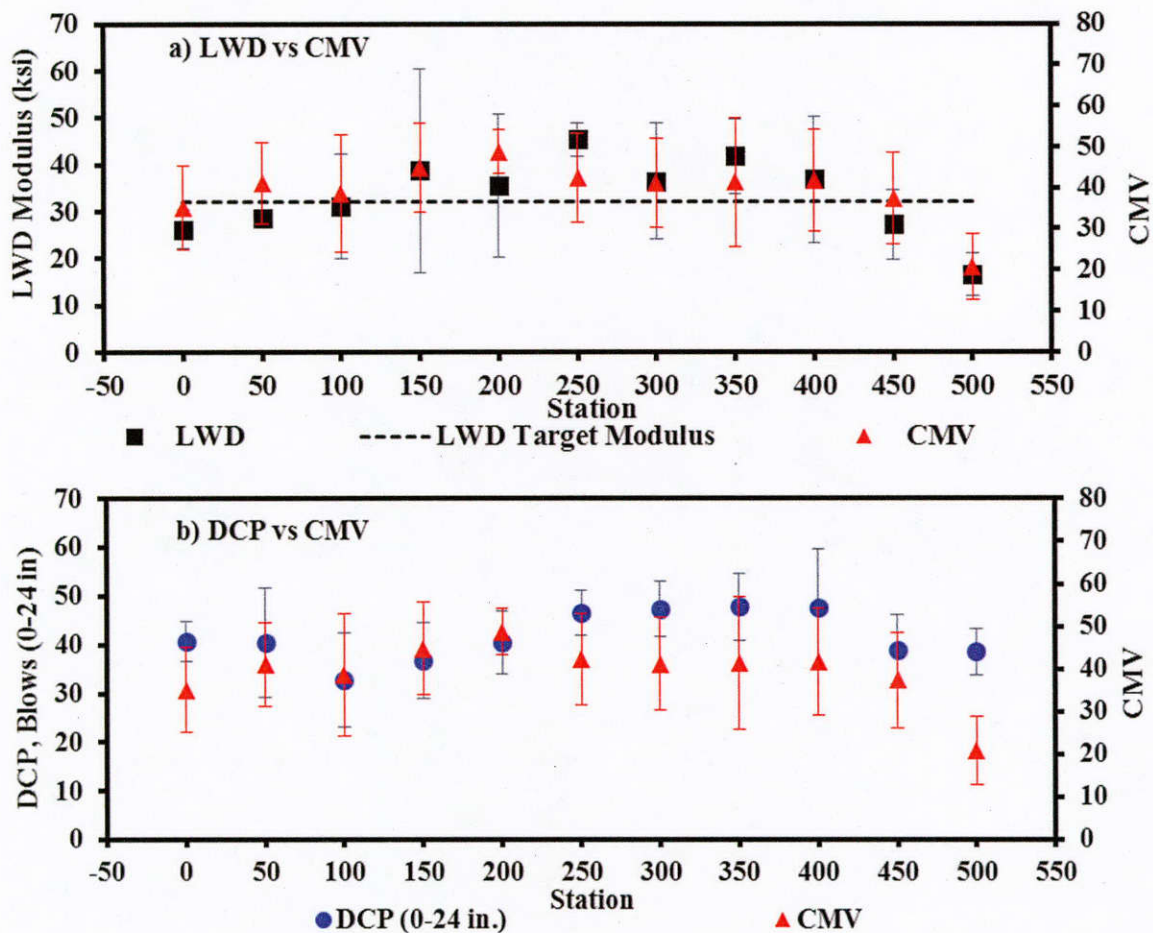


Figure G.10 – Relationship between averaged (a) LWD Modulus and (b) Number of DCP blows vs. CMV.

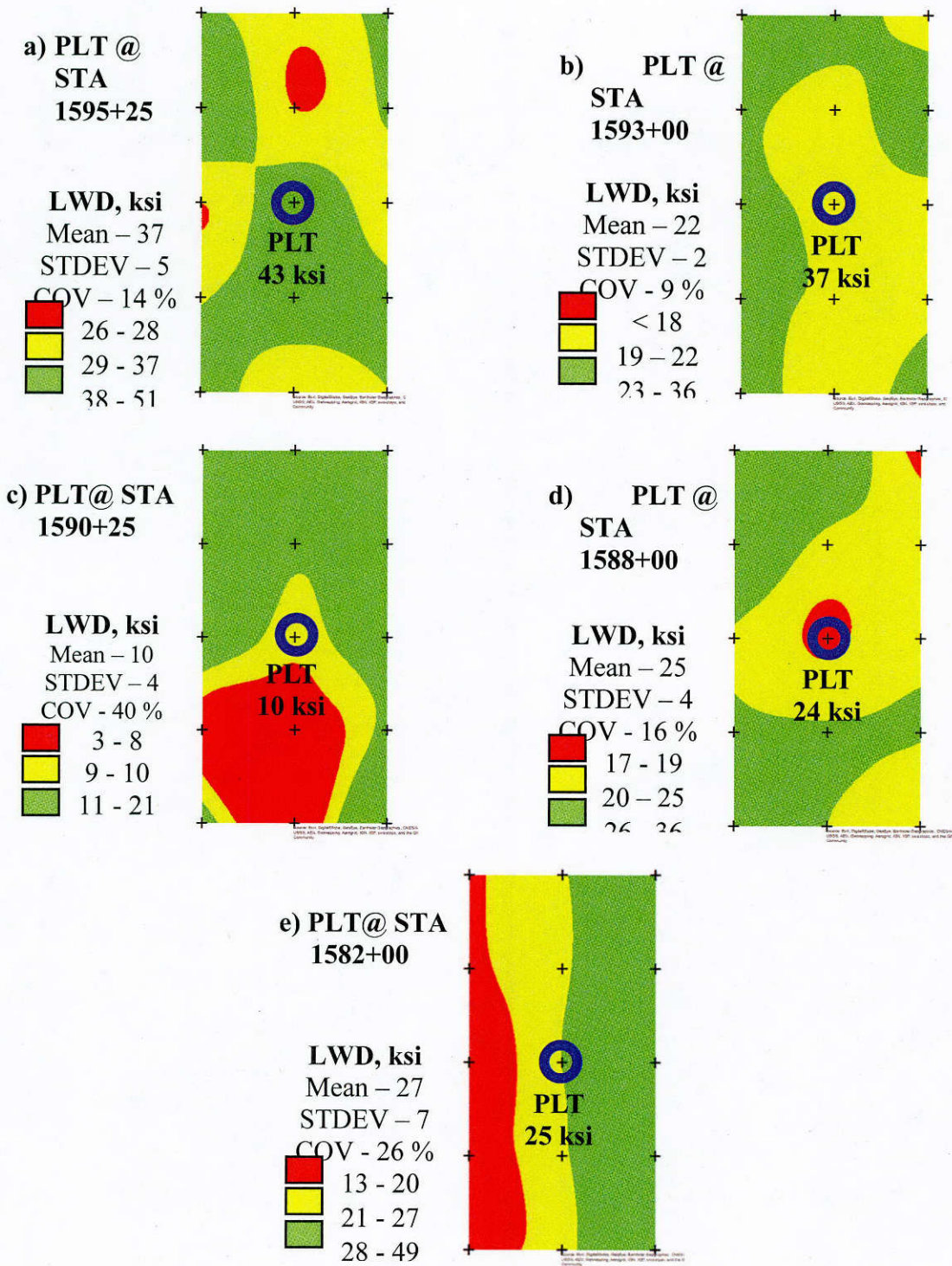


Figure G.11 – Spatial Distribution of LWD at Different PLT locations.

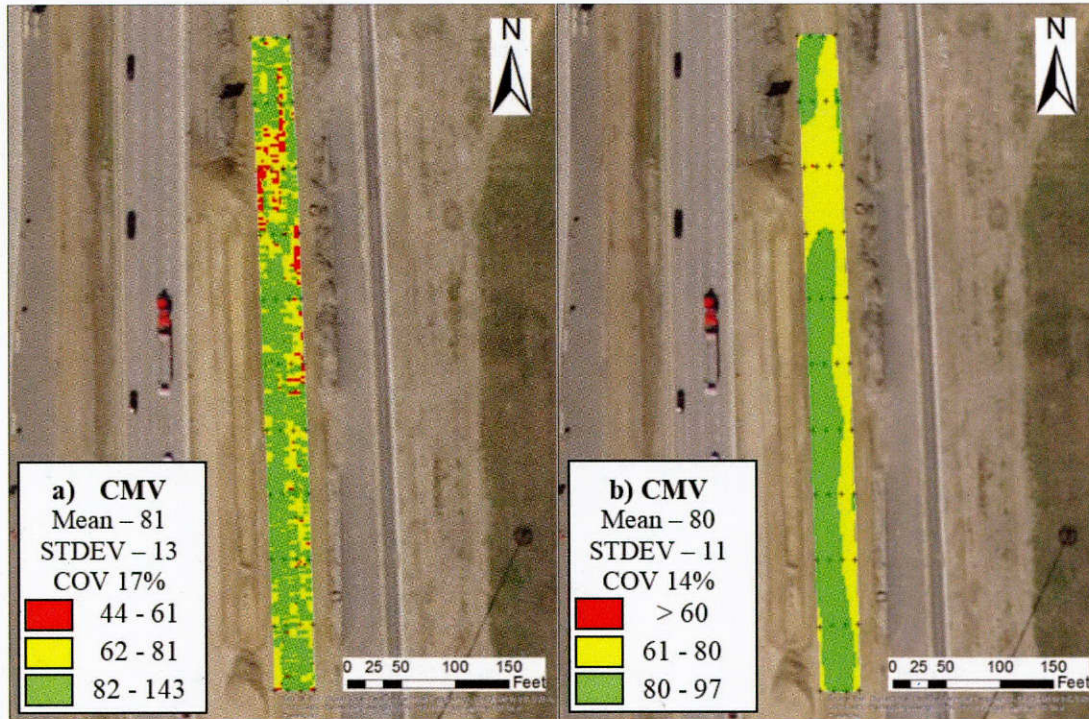


Figure G.12 - Spatial Distribution of (a) Raw and (b) Square Buffered CMV Data Collected by IC Roller during Proof-Rolling of Flexible Base Layer.

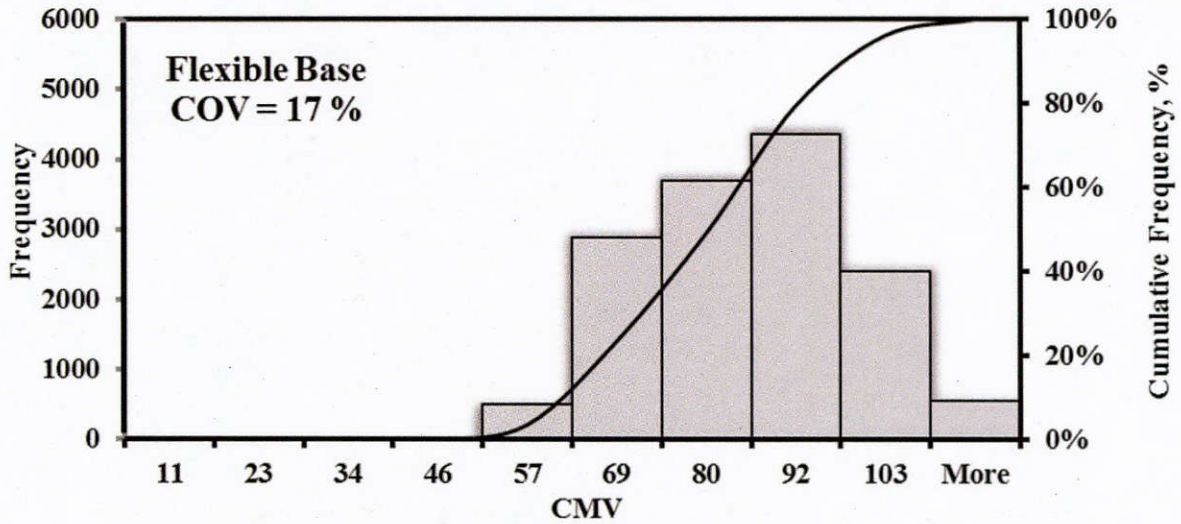
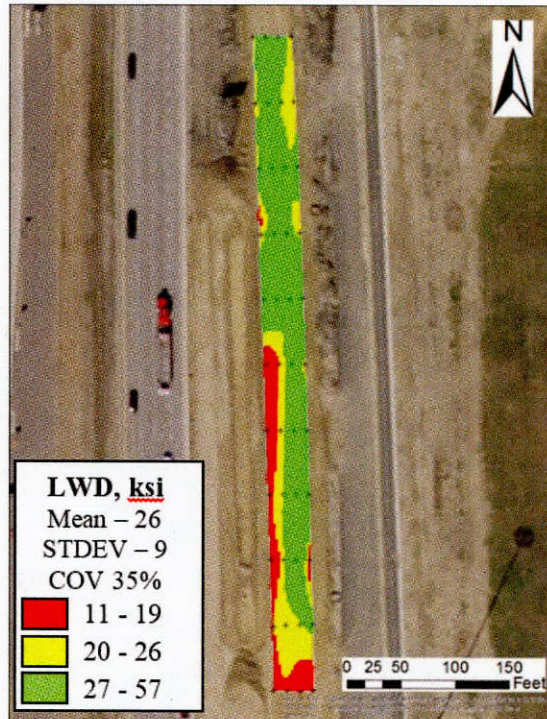


Figure G.13 - Distribution of CMV Data Collected by IC Roller during Proof-Rolling of Flexible Base Layer.



**Figure G.14 – Spatial Distribution of LWD Modulus of Flexible Base Layer.**

Figure G.15 summarizes the DCP results on the compacted FB layer. The estimated number of DCP blows required to penetrate to a depth of 12 in. ranged from 45 blows to 156 blows with an average of 100 blows and a COV of 26%. This is in agreement with the LWD geospatial distribution shown in Figure G.14 and bears resemblance to the CMV geospatial distribution shown in Figure G.12b. The cumulative distribution of the number of DCP blows is shown in Figure G.16. The distribution indicates the top 6 in. are stiffer requiring more blows to penetrate through them.



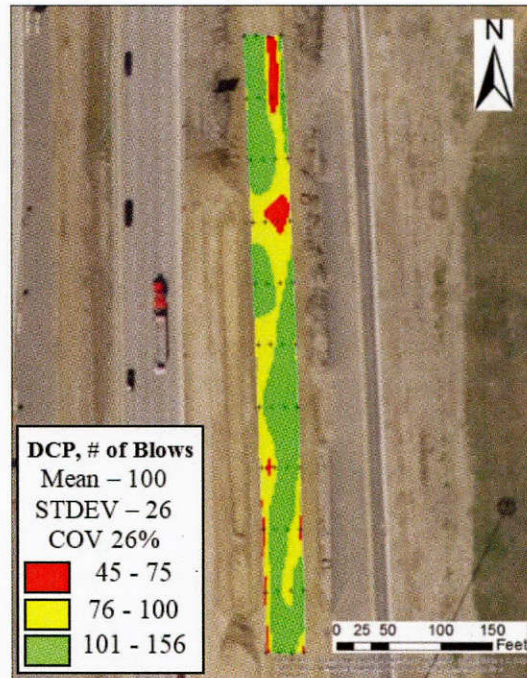


Figure G.15 – Spatial Distribution of Number of DCP Blows of Flexible Base Layer.

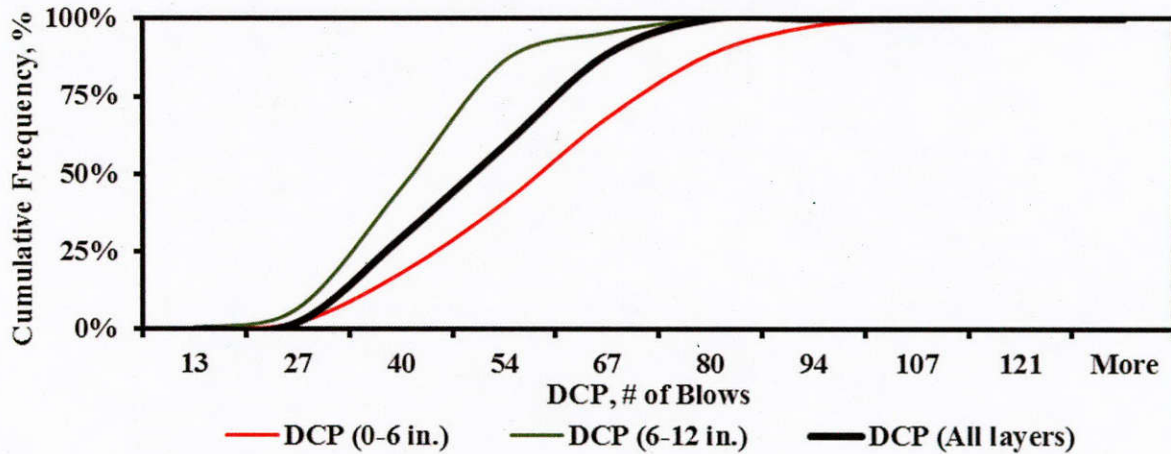


Figure G.16 – Cumulative Distribution of Number of DCP Blows of LTS Layer.

Figure G.17 illustrates the spatial distribution of the moisture content of the base layer. The moisture content varied from 5% to 19% with an average of 10% and a COV of 20%. Throughout the test section there was an even percentage of moisture content with only a section in the center showing a higher level of moisture. No well-defined visual resemblance was seen between moisture content and CMV.

A comparison between the LWD moduli and the CMV data at different stations is illustrated in Figure G.18a. The LWD moduli and CMV results showed some resemblance, though definitely not as strong as trends seen on the LTS, shown in Figure C.10a. Besides, most LWD moduli were below the target LWD modulus of 32 ksi. A similar comparison using the number of DCP blows and CMV data is shown in Figure G.18b. The trend observed for the number of blows per station was similar to LWD modulus.

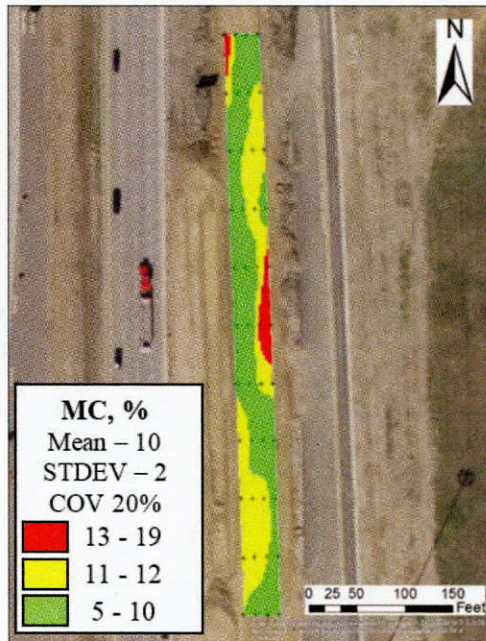


Figure G.17 – Spatial Distribution of Moisture Content of Flexible Base Layer.

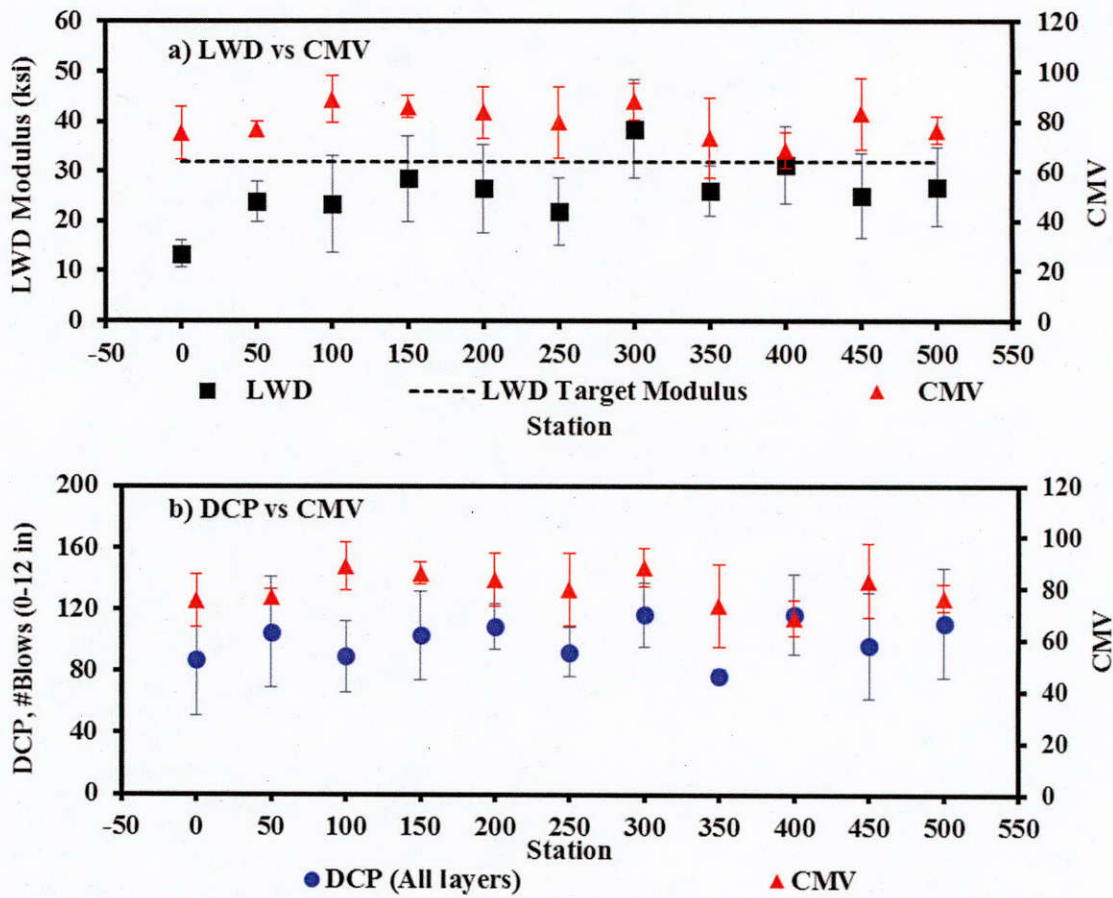


Figure G.18 – Relationship between Averaged (a) LWD Modulus and (b) Number of DCP Blows vs. CMV.



