



UWS Academic Portal

PANDI

Sturley, Sean; Matalonga, Santiago

Published in:

Proceedings of The 1st International Conference on Innovative Research in Applied Science, Engineering and Technology IRASET'2020

Accepted/In press: 22/02/2020

Document Version

Peer reviewed version

[Link to publication on the UWS Academic Portal](#)

Citation for published version (APA):

Sturley, S., & Matalonga, S. (Accepted/In press). PANDI: a hybrid open source edge-based system for environmental and real-time passive acoustic monitoring - prototype design and development. In *Proceedings of The 1st International Conference on Innovative Research in Applied Science, Engineering and Technology IRASET'2020: March 19-20, 2020, FS Meknes, Morocco* IEEE.

General rights

Copyright and moral rights for the publications made accessible in the UWS Academic Portal are retained by the authors and/or other copyright owners and it is a condition of accessing publications that users recognise and abide by the legal requirements associated with these rights.

Take down policy

If you believe that this document breaches copyright please contact pure@uws.ac.uk providing details, and we will remove access to the work immediately and investigate your claim.

“© © 2020 IEEE. Personal use of this material is permitted. Permission from IEEE must be obtained for all other uses, in any current or future media, including reprinting/republishing this material for advertising or promotional purposes, creating new collective works, for resale or redistribution to servers or lists, or reuse of any copyrighted component of this work in other works.”

PANDI: A Hybrid Open Source Edge-based System for Environmental and Real-Time Passive Acoustic Monitoring - Prototype Design and Development.

Sean Sturley

School of Computing, Engineering and Physical Sciences
The University of the West of Scotland
Glasgow, Scotland
<https://orcid.org/0000-0003-1056-059X>
sean.sturley@uws.ac.uk

Santiago Matalonga

School of Computing, Engineering and Physical Sciences
The University of the West of Scotland
Glasgow, Scotland
<https://orcid.org/0000-0001-5429-2449>
santiago.matalonga@uws.ac.uk

Abstract—Background: Improving the accuracy of bird population estimation is crucial for determining their species concern. In Scotland, several species, including the Eurasian Bittern and the Corn Crake, pose challenges as their choice of habitat and behaviour makes it extremely difficult for researchers to obtain accurate population numbers. **Aims:** To identify the targeted species individuals and aid researchers in pinpointing their location. **Method:** A low-cost open-source Edge-based passive acoustic monitoring system was designed (PANDI). **Results:** The PANDI system design and initial validation are presented in this paper. **Future work:** Include increasing classification accuracy and scope and commencement of long-term field-trials.

Keywords—Passive Acoustic Monitoring, Habitat Monitoring, ESP32, Raspberry Pi Zero, Sensors, Machine Learning, LoRaWAN.

I. INTRODUCTION

There are many bird species that have either a red or amber national rating on the Birds of Conservation Concern 4[1] and for any local conservation work to take place it is important to have an accurate population count.

Many surveying methods are available to researchers but there has always been, due to the nature and habitat of the survey species, problems with the accuracy of the research findings[2]–[4]. Two species have been chosen for this project as they pose problems for researchers, as they are very timid/secretive and they call at times of the day that are not easily sampled, and as such are referred to as “Crypto-Species”. They are the Eurasian Bittern (*Botaurus stellaris*) and the Corn Crake (*Crex crex*).

The PANDI System, which has been developed in collaboration with the Royal Society for the Protection of Birds (RSPB) and the British Trust for Ornithology (BTO), will assist field researchers in the real-time identification and plotting of the location of male Bitterns by their calls and will enable them to identify the territory of individual males. From this information, researchers can determine the likely location of nest sites, which would aid the researchers with allied conservation tasks such as ringing[5], from which nest survival rates can be collated to confirm the success of conservation and breeding campaigns[6]

With recent advances in low-power microcontroller functionality and performance, devices such as Arduinos and

Raspberry Pi’s are becoming the platform of choice for environmental and ecological research projects[7].

A self-build infrastructure can provide a cost-saving when compared to commercially available products[8]. However, it may also be that there is a requirement for more control of the configuration and deployment of the equipment in the field e.g. extra microphones, the addition of cameras, etc[9].

Several solutions, such as “Solo”[8] and “AudioMoth”[10], have been put forward to address the cost implications for large Passive Acoustic Monitoring (PAM) studies and the “RPI Ecosystem Monitoring System”[9] looks to address the power management issues of long-term field deployment. The PANDI System looks to not only provide a cost-effective PAM tool but to extend both the traditional functionality and the amount of time that it can be actively monitoring in the field.

The majority of PAM studies either deploy the equipment and collect the recording at the end of the project or periodically collect the samples for offline analysis[11]. However, by using localised Machine Learning to classify bird calls in real-time it is possible for the researcher to react to the presence of a bird quickly and perform additional research tasks, such as nest inspections or localised prey sampling.

II. MATERIALS

PANDI seeks to provide researchers with a readily adaptable platform that can be modified or augmented to take advantage of the rapid advances in microcontroller technology, such as new feature availability and performance improvements that may occur throughout the time frame of a research project.

A. Microcontroller Selection

The PANDI system is designed with customization at its core. The two-node system, illustrated in Fig. 1, allows the system to be adapted to meet the power needs and functionality for any PAM project, and the rationale for microcontroller selection will be dependent on the individual research requirements.

1) PANDI Control Node (PCN).

The selection of the microcontroller platform should provide as much natively supported functionality as possible to limit the use of additional components. In this instance, there are two critical requirements:

a) Due to the nature of this project, there is limited consistent cellular or wireless network coverage, therefore a platform that supports data transmission over a Long Range (LoRa), low-power wide-area network (LPWAN) technology with a practical range in rural areas of approximately 6km[12] is required.

b) This project also requires accurate time alignment between all the sensor nodes in the wireless sensor network (WSN) therefore a microcontroller platform with an integrated Global Positioning System (GPS) chipset should be selected.

For the initial testing of the PANDI system, a TTGO T-Beam was selected as a suitable platform for the control node.

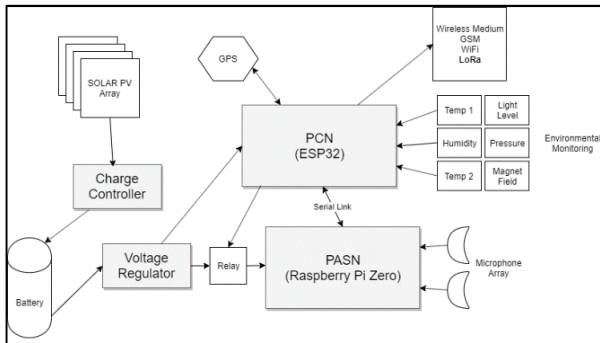

Figure 1 - Block diagram of the PANDI System.

2) PANDI Acoustic Sampling Node(PASN)

The choice of PAM node depends wholly on the level of complexity required by the project. In this instance, there exists a requirement not only to take acoustic samples but also to filter and analyse them. If the PANDI System were to be used only for PAM, then it would have been possible to undertake both the acoustic and environmental monitoring with one microcontroller. However, it is possible to leverage the hybrid nature of the PANDI system to utilize the strengths of other microcontrollers for the PASN.

For this project, the Raspberry Pi Zero was chosen because:

a) from a hardware perspective, it has support for microphones via USB and GPIO.

b) from a software perspective, all the additional functionality required for Acoustic Sampling and Machine Learning is supported natively and can be managed via python scripts or crontab entries.

B. Power Management

With projects that have a remote deployment requirement, there are two factors that have a significant impact on the success of a sensor-based project. These are the interconnectivity of the nodes[13] (discussed in section D) and the management of power usage[14].

Because the species being monitored require as little disturbance as possible, the PANDI System is designed to be remotely deployed for several months. To achieve this long term deployment the PANDI Systems takes advantage of the Ultra-Low Power Mode[15] of the ESP32 to extend deployment time over existing PAM systems.

The system will be battery powered with a solar charging system as a back-up to ensure functionality of the system for

the duration of the deployment. The power budget available for the system is calculated to ensure sufficient residual power is available to the system to cope with issues such as prolonged periods of inclement weather, and the charge is monitored and reported periodically via LoRa.

C. Environmental Sensing.

A controller node was chosen that had specifications that provided best fit for the research project requirements without the addition of external sensors.

However, for this project, there is a requirement for accurate environmental measurements as it is hoped that future analysis of the environmental data can be directly correlated to any factors that govern the timing of male Bittern calls. Separate sensors will therefore be used to record the following:

1) Temperature 1, Humidity and Pressure.

BME280 – This is a high-performance digital sensor which supports both SPI and I²C interfaces and is capable of operating in multiple power modes[16]. This sensor is used to capture readings at a point incident with the PASN (Approximately 1.5m above ground level) and has a temperature measurement range(-40 to +85°C) comparable with the DS1820

2) Temperature 2

DS1820 – This is a low power, high precision digital thermometer capable of measuring temperatures between -10 and +85°C. This device can be powered either directly or via parasitic power and has a current draw of 1mA when active[17]. In this instance, this sensor is used to record the temperature at ground level.

3) Light Levels

TEMT6000 – This is an ambient light sensor Module which is traditionally used for measuring light levels for the automated dimming of such things as LCD screens[18]. The sensor is used to accurately measure and record the ambient light level throughout the project.

4) Magnetometer.

HMC5883L - This triple-axis magnetometer is highly sensitive and capable of both directional and magnitude sensing of magnetic fields. It has a low power requirement and an operating temperature range compatible with the other sensors[19] and is used to record magnetic field strength levels throughout the project.

D. Interconnectivity and Communication Stack.

The PANDI system relies on connectivity to add value over alternative PAM solutions. The results of real-time analysis of bird calls are forwarded to a cloud-based system for storage and analysis. As a principle of their design[13] WSN's have a reliance on local wireless or Bluetooth connections for the collection or transmission of sensor data between the sensor nodes and the collection node. However, having considered the potential distances between the sensor nodes and the relative power usage of Bluetooth and wireless connections, both have been ruled out in favour of a WSN based on LoRaWAN (See Fig 2).

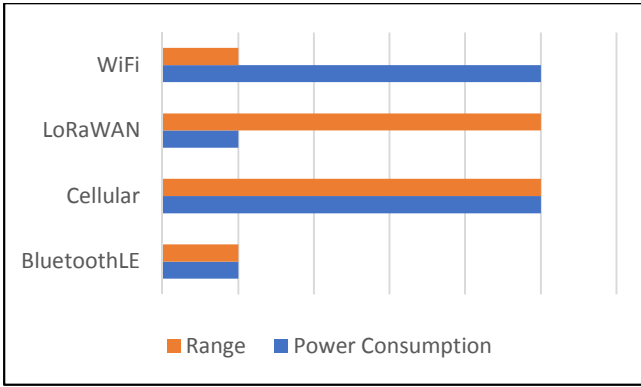

Figure 2 - Range vs Power Consumption (adapted from [20])

E. LoRaWAN Infrastructure

The PANDI System nodes securely connect, by means of a pre-shared network (NwkSKey) and application (AppSKey) session key, to the LoRaWAN infrastructure via a LoRa Gateway which forwards packets to corresponding Network Servers. These in-turn route them onto the correct Application Server where they are stored and processed. Fig 3 shows an example of the network architecture of the “The Things Network” (TTN) which shows the structure of an example pathway for LoRa packets.

III. METHODOLOGY

A. Systems Overview

Fig 4 presents an operational overview of the PANDI System. The system consists of Sensor nodes and a Cloud-based system. The Sensor nodes are responsible for collecting environmental samples and classifying bird vocalisation. Bird vocalisations are classified locally, and only positive samples are transmitted to the Cloud System thus reducing any unwanted, and potentially costly, network traffic. The Cloud System is responsible for the storage of environmental data and triangulating the correctly classified calls, as well as providing a usable user interface for the researcher. The following sections describe each element depicted in the diagram.

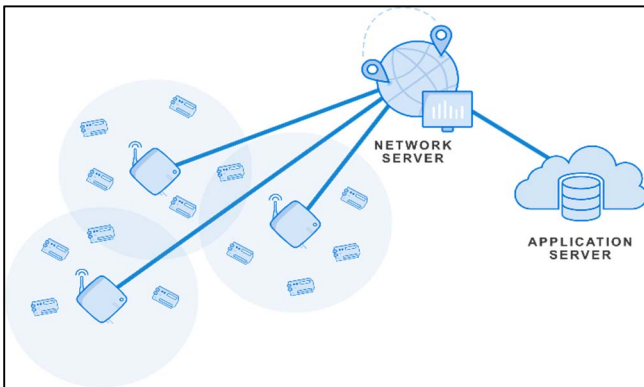

Figure 3 - TTN's LoRaWAN[21]

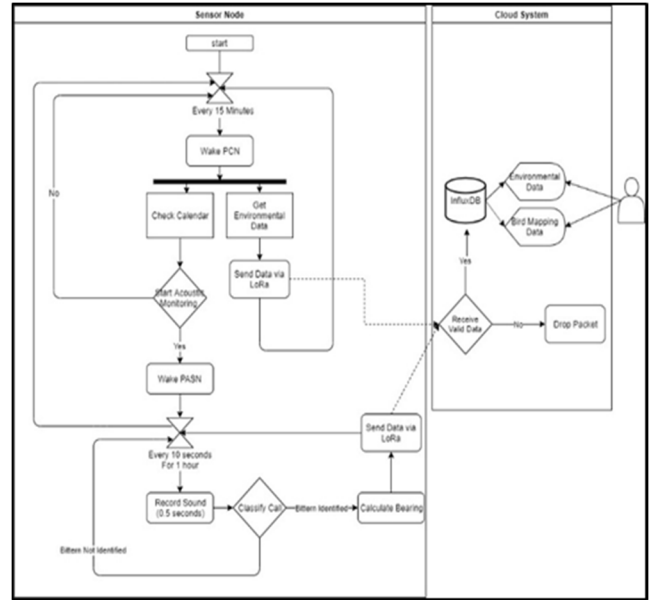

Figure 4 - Operational view of the PANDI System

B. PASN Training

There are several open-source machine learning environments that have support for both image and audio classification, such as Caffe, PyTorch and TensorFlow. Of these, TensorFlow was chosen as it provides support for multiple platforms. TensorFlow Lite can produce classifiers that can be deployed to a Raspberry Pi. The machine learning model used in our deployment is a Convolutional Neural Network (CNN) as the research has shown that they are very effective for the classification of audio [22], [23].

The TensorFlow Lite classifier is trained with audio samples provided by the RSPB and uploaded to the Xeno-Canto.org website. The audio is sampled using fixed-length windows with an overlap in Fig 5. as this has been shown to produce samples which lead to a more accurately trained classifier. The audio samples are then processed to produce a Mel Frequency Cepstral Coefficient (MFCC) for the sample to be classified, as the “image like” qualities of an MFCC work well with CNN’s which were originally developed for image classification[24].

Once the CNN has achieved a suitable training accuracy it will be assessed against samples from outside the original training set to gauge the testing accuracy before field deployment.

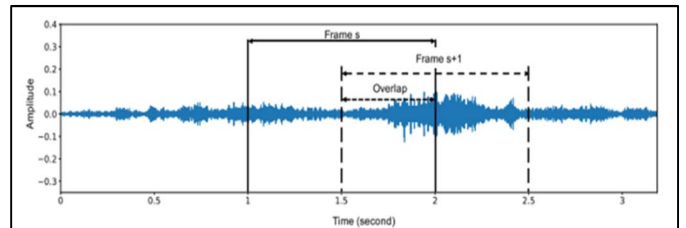

Figure 5- Overlapping samples for increased training accuracy[25]

C. Data Collection and Transmission

To conserve energy the PCN is maintained in Ultra-Low Power (ULP) mode[15] and the state of the PANDI System

is managed by predefined calendar script which the PCN uses to manage the status for both itself and the PASN.

The PANDI System has two states:

1. Non-Acoustic Sampling Cycle (NSC) which is the default dormant state utilising the power saving gains of ULP mode.
2. Acoustic Sampling Cycle (ASC) which is an active state.

During the NSC, the PCN is “woken” every 15 minutes to collect environmental readings from the sensors, which it then forwards via LoRa. Depending on the research project’s requirements, and at predetermined times the PCN enters the active state and the PANDI system enters an ASC. Using an electrically controlled relay, the PCN awakens the PASN, which powers on and enables the GPS to get an accurate time update so that it can, if necessary, adjust its internal Clock. Once this preliminary step is done the PANDI system begins taking and analysing audio samples.

During the ASC a half-second 48000Hz sample is taken every 10 seconds – Fig 6, from each microphone to which a Low-pass filter with a ceiling frequency of 1000Hz and Roll-off of 48dB per octave is applied to isolate the Bittern calls from other birdsong. The two samples are analysed and from the strongest sample, an MFCC is calculated which is processed by a trained machine learning classification model. If the MFCC is positively classified by the classification model as containing a Bittern call, then both of the audio samples and the MFCC are stored locally.

The samples are analysed to identify the Time Difference of Arrival (TDoA) of the bird call at the PASN. When the TDoA has been calculated for each successfully classified sample it is then possible to compute a bearing, relative to the sensor, for the source of the call[26].

Once a bearing has been calculated the PASN then collates accurate time data (in the format YYYYMMDDHHMMSS), a classification identifier (which is a placeholder for future features) and a directional 3 digit bearing (e.g. 045 degrees) into a string composed as shown below:

Timestamp + 1 + bearing = “201904151052211045”

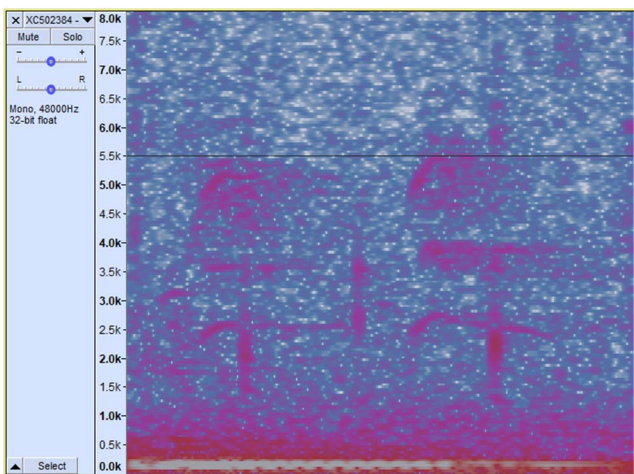

Figure 6- Half second acoustic capture showing unwanted birdsong above 1000Hz.

This variable is also stored locally for extraction later and is transferred via a serial connection to the PCN which, during the ASC, checks the status of the variable and on detection of a change transmits it over LoRaWAN to a LoRa Gateway, encrypted with the AppSKey. The Gateway forwards data packets, dependent on the NwksKey, to a LoRa Network Server. These packets are then forwarded to a LoRa Application Server which uses AppSKey to decrypt and in turn de-encapsulate the data packet.

D. Data Processing, Display and

Integration services running on the Application Server allow for all successfully de-capsulated packets, to be logged to a database server, in this instance InfluxDB, from which the node data can be further analysed for:

1. Environmental Data.

A Grafana instance is attached to the InfluxDB database and a plot can be produced for each node deployed in the PANDI System as shown in Fig 7.

2. Locational and Triangulation Data

For each PANDI system deployed the database can be queried periodically, the period of which dictates the “real-time” nature of the data visualisation for classified calls. The results of these queries are published as a JavaScript Object Notation (JSON) file which can be published for import to other systems. The bearings for each classified call are obtained by using jQuery to import the values from the JSON file and plot bearing lines for each classified call. As plots are made for each node with corresponding timestamps the intersections can be logged, as seen in Fig 8, and over time used to deduce the territory of specific males.

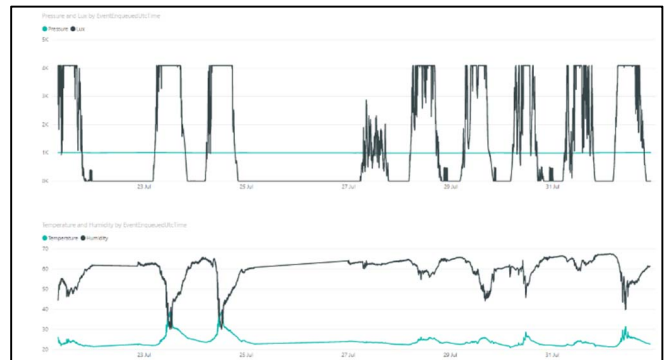

Figure 7- Plots of Environmental Data from a node.

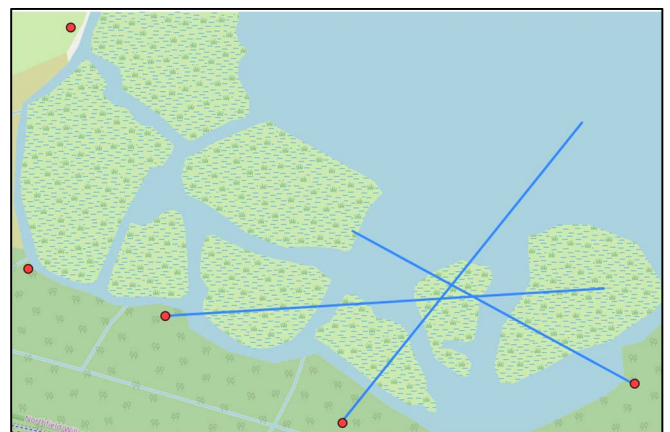

Figure 8 - Plots of bearings from classified Bittern calls.

3. Habitat or Species Specifications.

Once a territory has been successfully mapped correlations between the environmental data and the calls can be investigated to allow researchers to discover whether there is a relationship between environmental factors and, for example, the timing of mating calls or the choice of nesting sites.

IV. FUTURE WORK

Future steps for the project are to firstly improve the accuracy of the classification and allow for multiple species to be identified during the sampling sessions. Secondly from this data, to further train the system to enable the identification of individual males and their specific calls, as this could allow insight into such behaviours as territory defence and polygamy.

With further field trials, the team is looking to investigate a single-board solution that leverages the adaptability of the PCN with the computing power of the PASN.

V. ACKNOWLEDGEMENTS

The authors would like to thank several people without whom this project would still be scribbles on a piece of paper. Stuart Newson, of the BTO, whose initial guidance helped bring a focus to the project, and in turn provided direction. Gillian Gilbert, of the RSPB, and her team of researchers for their hard work producing and cataloguing the hours of recordings used in the development of the TensorFlow training set. Jaume Segura and Jose Alcaraz-Calero for their advice on audio manipulation on microcontrollers. Finally, to Simon Chapple and Richard Jackaman, of Edinburgh University's IoT Research & Innovation Service, for their help through the undocumented minefield of LoRaWAN infrastructure.

VI. REFERENCES

- [1] M. Eaton *et al.*, "Birds of Conservation Concern 4: the population status of birds in the UK, Channel Islands and Isle of Man," 2015.
- [2] C. J. Bibby, N. D. Burgess, and D. A. Hill, "Point Counts," *Bird Census Tech.*, pp. 85–104, 1992.
- [3] R. D. Gregory, D. W. Gibbons, and P. F. Donald, "Bird census and survey techniques," in *Bird Ecology and Conservation*, no. June 2004, Oxford University Press, 2004, pp. 17–56.
- [4] R. D. Applegate, R. E. Kissell, E. D. Moss, E. L. Warr, and M. L. Kennedy, "Problems with Avian Point Counts for Estimating Density of Northern Bobwhite—A Case Study," *J. Fish Wildl. Manag.*, vol. 2, no. 1, pp. 117–121, Jun. 2011.
- [5] Stephen Baillie *et al.*, "EURING Bird Ringing for Science and Conservation," 2007.
- [6] R. A. Robinson, C. A. Morrison, and S. R. Baillie, "Integrating demographic data: towards a framework for monitoring wildlife populations at large spatial scales," *Methods Ecol. Evol.*, vol. 5, no. 12, pp. 1361–1372, Dec. 2014.
- [7] S. Ferdoush and X. Li, "Wireless Sensor Network System Design Using Raspberry Pi and Arduino for Environmental Monitoring Applications," *Procedia Comput. Sci.*, vol. 34, pp. 103–110, 2014.
- [8] R. C. Whytock and J. Christie, "Solo: an open source, customizable and inexpensive audio recorder for bioacoustic research," *Methods in Ecology and Evolution*, vol. 8, no. 3. 2017.
- [9] S. S. Sethi, R. M. Ewers, N. S. Jones, C. D. L. Orme, and L. Picinali, "Robust, real-time and autonomous monitoring of ecosystems with an open, low-cost, networked device," *Methods Ecol. Evol.*, vol. 2018, no. August, p. 236075, 2018.
- [10] A. P. Hill, P. Prince, E. Piña Covarrubias, C. P. Doncaster, J. L. Snaddon, and A. Rogers, "AudioMoth: Evaluation of a smart open acoustic device for monitoring biodiversity and the environment," *Methods Ecol. Evol.*, vol. 9, no. 5, pp. 1199–1211, 2018.
- [11] E. Browning, R. Gibb, P. Glover-Kapfer, and K. E. Jones, "Passive acoustic monitoring in ecology and conservation," *WWF Conserv. Technol. Ser. 1*, vol. 2, pp. 1–75, 2017.
- [12] R. Sanchez-Iborra, J. Sanchez-Gomez, J. Ballesta-Viñas, M.-D. Cano, and A. Skarmeta, "Performance Evaluation of LoRa Considering Scenario Conditions," *Sensors*, vol. 18, no. 3, p. 772, Mar. 2018.
- [13] M. T. Lazarescu, "Design of a WSN Platform for Long-Term Environmental Monitoring for IoT Applications," *IEEE J. Emerg. Sel. Top. Circuits Syst.*, vol. 3, no. 1, pp. 45–54, Mar. 2013.
- [14] J. Polastre, R. Szewczyk, A. Mainwaring, D. Culler, and J. Anderson, "Analysis of Wireless Sensor Networks for Habitat Monitoring," in *Wireless Sensor Networks*. Boston, MA: Springer US, 2004, pp. 399–423.
- [15] Espressif Systems, "ESP32 Series Datasheet," *espressif.com*, 2019. [Online]. Available: https://www.espressif.com/sites/default/files/documentation/esp32_datasheet_en.pdf. [Accessed: 24-Nov-2019].
- [16] Bosch Sensortec GmbH, "Combined humidity and pressure sensor - BME280 Datasheets," Reutlingen, Germany, 2018.
- [17] Maxim Integrated Products Inc, "High-Precision 1-Wire Digital Thermometer: DS1820." pp. 1–21, 2015.
- [18] Vishay Semiconductors, "TEMT6000 - Ambient Light Sensor." pp. 1–6, 2011.
- [19] Honeywell, "HMC5883L - 3-Axis Digital Compass IC." Honeywell International Inc, pp. 1–20, 2013.
- [20] J. De Carvalho Silva, J. J. P. C. Rodrigues, A. M. Alberti, P. Solic, and A. L. L. Aquino, "LoRaWAN - A low power WAN protocol for Internet of Things: A review and opportunities," in *2nd International Multidisciplinary Conference on Computer and Energy Science, SpliTech 2017*, 2017, no. July, pp. 1–6.
- [21] H. Visser, "Network Architecture | The Things Network," *The Things Network*, 2018. [Online]. Available: <https://www.thethingsnetwork.org/docs/network/architecture.html>. [Accessed: 20-Nov-2019].
- [22] J. Salamon and J. P. Bello, "Deep Convolutional Neural Networks and Data Augmentation for Environmental Sound Classification," *IEEE Signal*

Process. Lett., vol. 24, no. 3, pp. 279–283, Mar. 2017.

- [23] K. Piczak, “Recognizing bird species in audio recordings using deep convolutional neural networks,” *Work. Notes CLEF 2016 Conf.*, vol. 501, pp. 273–288, 2016.
- [24] S. K. Gouda, S. Kanetkar, D. Harrison, and M. K. Warmuth, “Speech Recognition: Keyword Spotting Through Image Recognition,” 2018.
- [25] S. Abdoli, P. Cardinal, and A. Lameiras Koerich, “End-to-end environmental sound classification using a 1D convolutional neural network,” *Expert Syst. Appl.*, vol. 136, pp. 252–263, 2019.
- [26] R. Roberts, “TDOA Localization Techniques,” 2004.