

Forest fire detection using wireless sensor networks

Prem Sai Dasari, Gundam Krishna
Jayanth Reddy and Abhishek
Gudipalli*

School of Electrical Engineering,
Vellore Institute of Technology,
Vellore, 632014, India.

*E-mail: abhishek.g@vit.ac.in

The paper was edited by
Chinthaka Gooneratne.

Received for publication
March 20, 2019.

Abstract

A forest has different types of vegetation like herbs, trees, shrubs and different species of animals. In one way or other, these renewable resources are very essential to mankind. Forest fires are the most common hazards in forests which lead to serious destruction of forest wealth, bio-diversity and natural habitat. Early detection and preventive measures are necessary to protect forests from fires. In order to achieve early detection, there are two most used traditional methods of human surveillance. One is directly through human observation and the other is through distant video surveillance. Doing the observation through distant mode, one can achieve surveillance through automation approach of detection. Automated fire alert detection system proposed in this paper comprises of two sensors, namely smoke and fire. These sensors detect change in a measurable physical quantity and help in the early detection of a forest fire. A key feature of this fire detection system is to alert the user remotely by using a GSM module, whenever a fire is detected.

Keywords

GSM (global system for mobile communication), Smoke sensor, Flame sensor, WSN (wireless sensor network), Surveillance, RF (radio frequency).

Fire is an unwanted event. Forest fire is an uncontrollable fire happening in wild forests. It is essential to detect these fires at the right time to prevent the damage to the biological ecosystem. There is a continuous increase in forest fires, in which the land becomes unsuitable for cultivation (Basu et al., 2018). Lands become water repellent and make it difficult for growing crops. An uncontrolled forest fire can destroy everything in its way, spread for miles, crossing waterways. Every year, about 60,000 to 80,000 forest fires are occurring and crushing land in the range of 3 to 10 million hectares (Tikhe and Rail, 2018). The Global warming report 2008 states forest fire as one of the significant reasons behind increment in worldwide warming. In Uttarakhand, 4,000 hectares forest land was burnt and noted number one among the unstoppable fires record (Singh et al., 2017). This demonstrates these fires cause an extraordinary loss to social wealth as well as human life. Depending upon the distinctive causes, there will

be diverse consequences to nature. Common reasons of forest fire are lightning, hot weather conditions and human carelessness (Basu et al., 2018).

A couple of hundred years ago, forest fires were of natural action caused mostly by uncommon volcanic emission or a quake or lightning (Singh, 2016). But the present scenario replaces natural causes with human causes, which are in greater number and natural causes are less in number (Stipaničev et al., 2006). So there is an urgent need to build up a framework that could recognize and caution the concerned specialists about the fire, right on time (Arun Ganesh et al., 2013; Pirbhulal et al., 2017). The fire alert system proposed in this paper includes the utilization of reasonable instruments, connectivity and using wireless communication. The fire alert system has low power utilization and quicker handling capacity at a lower cost and maintenance (Kumar et al., 2017; Othman et al., 2012).

Literature survey

Numerous solutions have been proposed and implemented for this problem. Most common systems used in field work are video surveillance systems. Video cameras are sensitive to smoke only in day time. Fire sensitive cameras at night, using IR thermal imaging cameras for heat flux detecting and using backscattering of laser light, detect the smoke particles. This fire alert system has a few limitations because of environmental conditions like dust particles, mist, shadows and so on. Another method is automated picture capturing of fires in forest. Capturing can be done by the cameras which are placed on top of towers. A motor was introduced to give a coverage view on the forest and for its movement (Basu et al., 2018). Captured pictures are processed using program or MATLAB simulation and matching with references taken at beginning stage. This alert system has limitation of false caution rate and visual cameras installed on towers are of high cost. Another method of fire detection is by using satellite systems. Base station collects the information sent by the satellite and runs an algorithm to recognize the facts (Basu et al., 2018). The raw data of satellites are processed and then Advanced Very High Resolution Radiometer instrument is utilized to recognize hotspots. In South Korea, forest fire surveillance system was proposed by using wireless sensor networks. Wireless sensor networks detect humidity and an application analyses the collected information (Hariyanwal et al., 2013; Kumar et al., 2017). In this methodology, there is some loss of information during communication. By using temperature sensor and GPS modem, forest fire detection can be possible (Basu et al., 2018). Here, temperature sensor collected data were sent to base station by both primary and main antennas (Alahi et al., 2017). Continuous power supply was difficult for too many antennas and sensors. In addition to the above limitations climatic changes may affect the system.

In a research done by Zhang et al. (2009), Pirbhulal et al. (2017), and Alahi et al. (2017) an *ad hoc* network using cluster topology for forest fire forecasting model was used to predict fire prone areas. It was concluded that WSNs have greater advantages.

In another research done by Demin et al. (2014), sensors were deployed and the weather data were collected. This data were used to calculate and prevent forest fires.

In these researches, there was no real-time forest fire monitoring, only the data were collected and fire prone areas were predicted.

Libelium (Solobera, 2010) developed a waspmote which has four sensors for measuring gases,

temperature and humidity. It gives early warnings and consumes very less energy.

Proposed methodology

Fire alert system comprises of three important stages: sensing, routing and communication. For sensing the physical change in environment, a couple of sensors are used, namely smoke and fire sensor (Alahi et al., 2018). MQ-2 smoke sensor has very high sensitivity toward propane, methane, LPG, smoke, alcohol, carbon monoxide and hydrogen. MQ-2 gas sensor is made up of aluminium oxide and has a coating of tin dioxide (SnO_2). SnO_2 is the most important material being sensitive toward combustible gases. At the point of target if combustible gases exist, the sensor's conductivity rises correspondingly with a rise in concentration of combustible gases at target. Another key sensor in the project is the fire sensor, which is highly sensitive and responsive in the presence of a fire (Alahi et al., 2018). These two sensors help detect a fire in the forest and transmit the data to the leader node via RF transmitter and receiver. The leader node analyses data from all the slave nodes in its cluster and if there is a fire at any node, then it will immediately communicate with the base station using GSM modem. GSM stands for global system for mobile communication, which consists of transmission and reception pins. GSM can receive and send messages and it can be interfaced to a computer or to a microcontroller. GSM module has a very wide coverage and is very energy efficient. The base station is alerted immediately when a node detects fire.

System architecture and working

Figure 1 shows the architecture of the proposed fire alert system. It uses fire and smoke sensors. These sensors will detect physical changes in environment and convert that detected physical change into a signal which can be measured electrically. We use crystal oscillator to produce a repetitive signal for increasing system performance. When the sensor detects something, it transmits to master node by using RF transmitter and receiver. Then the master node in turn transmits received data to base station where user can reach it.

Software approach of fire alert system

For software simulation of forest fire alert system, OMNeT++ software is used. OMNeT++ stands for Objective Modular Network Tested in C++, which is a modular, component-based C++ simulation

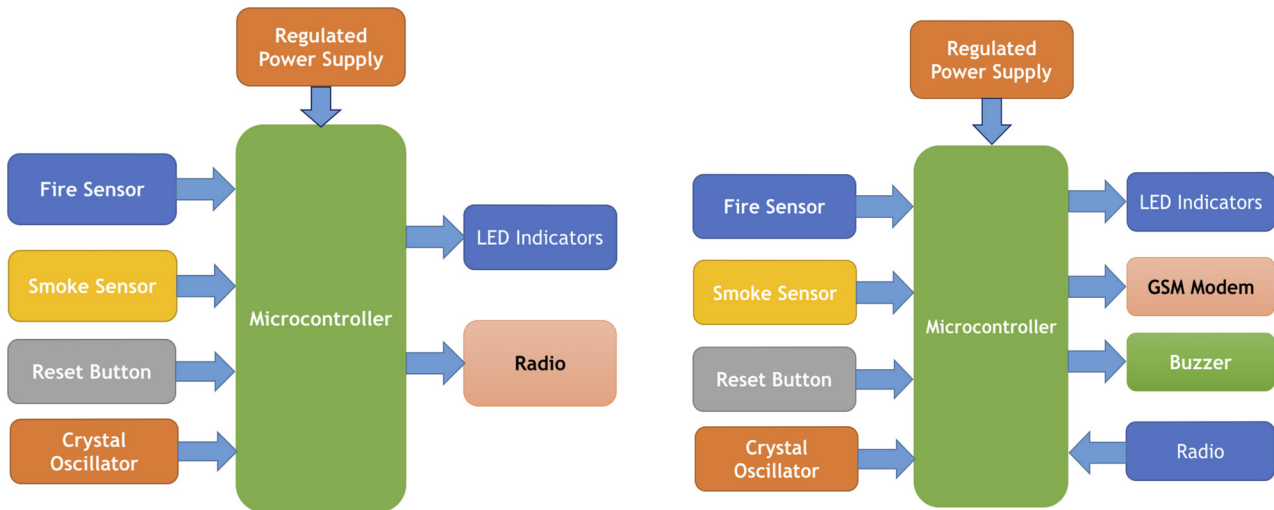

Figure 1: Block diagram of fire alert system with transmitter and receiver.

library and framework, primarily for building network simulators. Combination of many nodes is referred as a network. OMNeT++ sensor network is a component-based network simulator. It supports various communication networks such as queuing networks, wired and wireless. OMNeT++ sensor network consists of group of nodes, which coordinate together to perform some specific task. Every sensor node is fitted to an on-board processor and processed to calculate computation and transmission of required data. Wireless sensor networks are programmed to monitor and get environment view continuously.

Software simulation is done in four steps as shown below:

- Step 1: creating a new project.
- Step 2: adding a network description file (NED).
- Step 3: adding the C++ files.
- Step 4: adding initialization file (omnetpp.ini).

Create a new project and add the NED file. This file helps us to create topology based on our interest. User declares any number of simple modules and connects it to form a compound module. We need to implement the functionality of simple modules. The routing protocols are written in C++. To run the simulation, we need to create an initialization file. It tells the simulation program which network to simulate. Once we are done with all the four steps, we can build and run the simulation project (Figure 2).

In this project, eight slave nodes, two master nodes and one base station are used. Slave1 to

slave4 report to master1 and slave5 to slave8 report to master2 and a common base station for both the clusters. Polling technique is used as the routing protocol. Master node queries all the slave nodes (node 1, 2, 3 and 4) whether they have any data to transmit, the slave nodes reply if they have any data, master1 further transmits to the base station. If there is no data, the master node queries again. This process is repeated continuously. Similarly, process goes on with master2.

Hardware approach of fire alert system

Figure 3 shows the interface of sensors, transformer, rectifiers with PIC16F72 micro controller in the slave node. If the sensors in slave node detect any fire, the slave node transmits data to RF receiver at master node through RF transmitter.

The architecture of master node is shown in Figure 4. When the master node successfully receives data from slave node, the LCD display turns ON and displays "FIRE ALERT". This alert gets transmitted to the user via SMS by GSM modem.

The major hardware blocks present in the alert system are fire sensor, smoke sensor, micro controller, reset, crystal oscillator, LED indicators, GSM modem, RF transmitter, RF receiver, regulated power supply and step down transformer as you can see in Figure 5 (Figure 6).

A step down transformer converts high voltage into low voltage. The transformer is given 230V AC as, which is stepped down to 9V AC at the output pin. A bridge rectifier is used as its efficiency is

Forest fire detection using wireless sensor networks

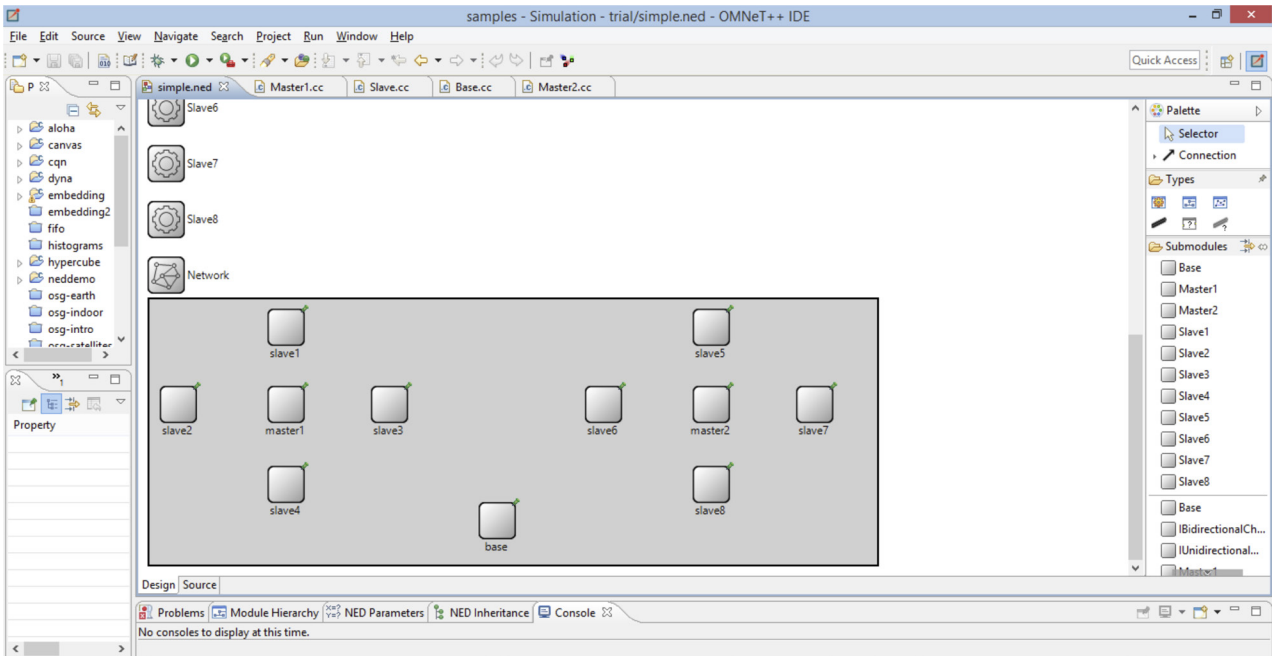

Figure 2: Software simulation of fire alert system using OMNeT++.

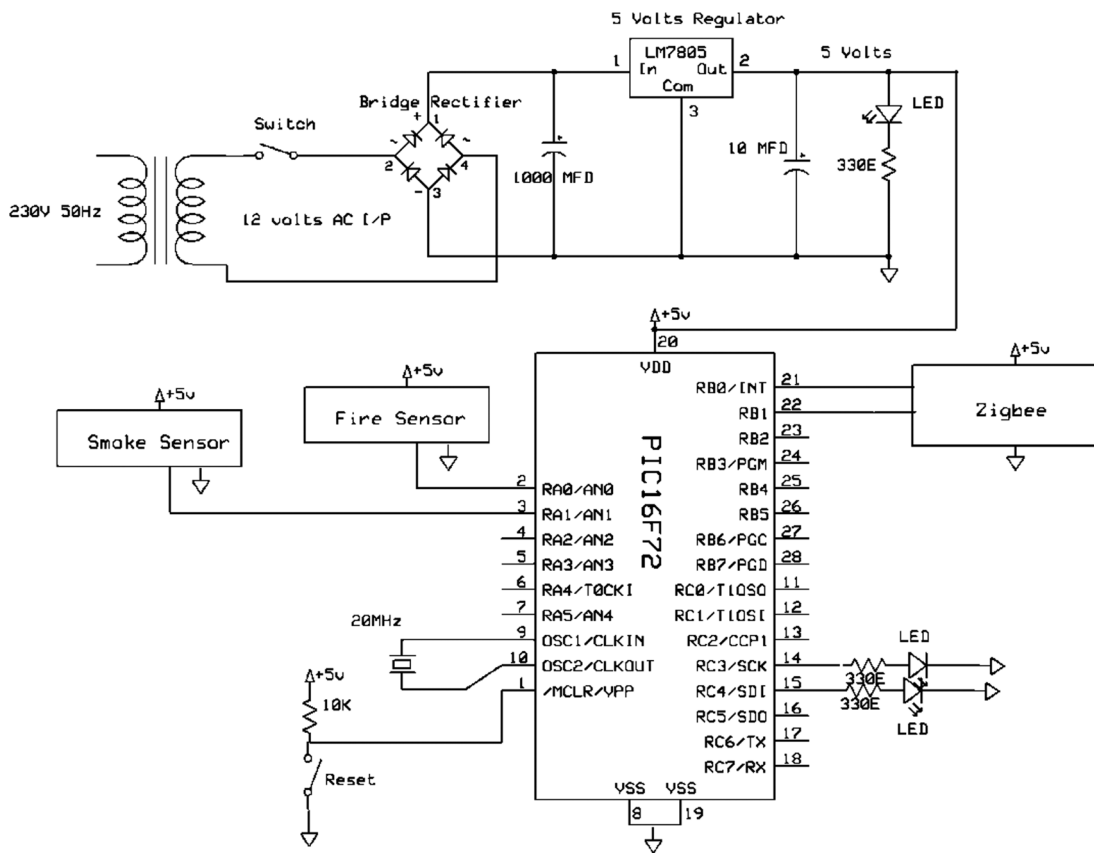

Figure 3: Schematic diagram and interface of PIC16F72 microcontroller with transmitter and RF module.

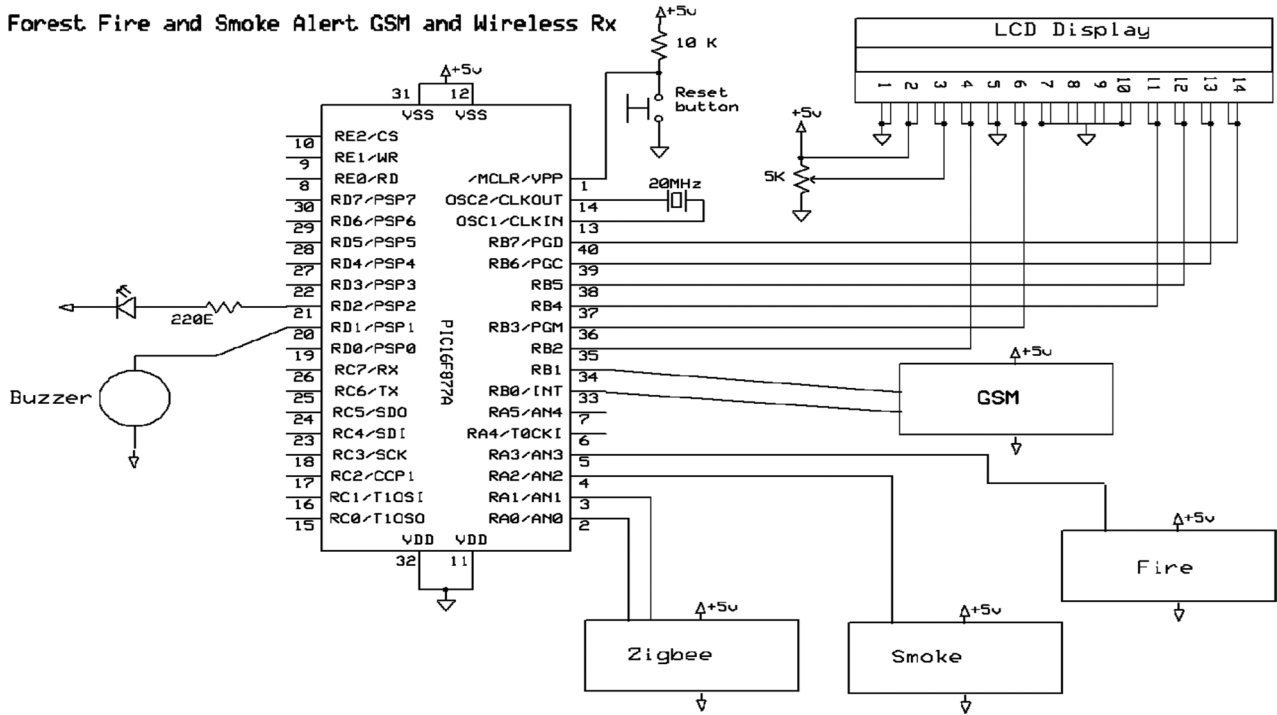

Figure 4: Schematic diagram implementation of receiver wireless sensor network for fire alert system.

higher compared to other rectifiers. The output of transformer is fed to the rectifier, which converts AC to DC. But this may not be pure DC, it is pulsating DC, because it contains some ripple components. So in order to eliminate these ripples present in the rectified output a filter is used. A capacitor filters out all the

DC ripples. But the output of the filter is not constant as it varies according to the changes in input. A constant supply is required for all the components to work properly. So, a voltage regulator is used for constant and continuous supply of voltage. By using 7805 voltage regulator, 5V constant output voltage is supplied. This DC voltage is supplied to the buzzer, LED's and other components. Crystal oscillator acts an external source to enhance clock frequency and a reset button for putting the microcontroller into a known condition.

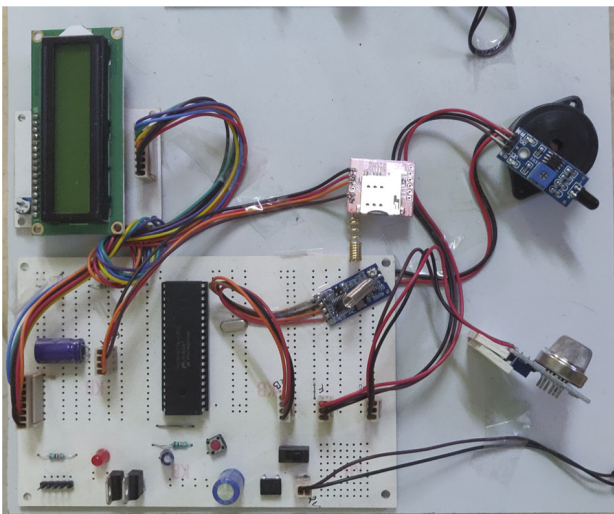

Figure 5: Master node of fire alert system with sensors and GSM modem.

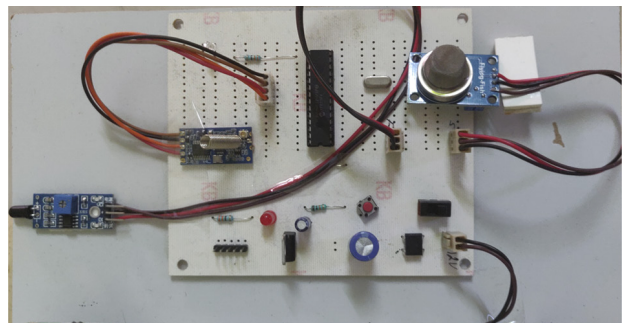

Figure 6: Slave node of fire alert system with sensors and RF module.

Forest fire detection using wireless sensor networks

In the hardware approach, the slave node and master node are embedded with all the parts mentioned above and a GSM modem (only for master node). When sensors detect fire or smoke, the data are sent to master node via RF transmitter and receiver. Then the buzzer makes a sound, the LED displays “SMOKE ALERT” or “FIRE ALERT” and an SMS is sent to the user by using GSM module.

Results and performance

The wireless transmission using RF, from one node to another node was experimented up to 100m. As there would not be any obstructions in the forest, the RF modules can work up to half a kilometer efficiently. For GSM module to work properly, there should be a minimum network coverage to send an SMS. The nodes can be placed 500m away from each other, for maximum coverage of the forest area with minimum number of nodes and to perform with good efficiency. Sleep-based topologies are also included so as to reduce energy consumption. The master node must have a bigger battery, because GSM module consumes higher energy. The fire and smoke sensors were tested up to 10m.

Software results

The master nodes ask for “DATA” from the slave nodes. The slave nodes at which there is a fire occurring, reply “FIRE_”. All the other nodes with no fire do not reply. For example, if there is fire at slave node 3, it replies “FIRE3”. In the next cycle, the master node informs Base station with “FIRE AT_”.

The cycle of instructions is as follows:

- The master node asking for “DATA” (Figure 7).
- The slave node where fire is occurring, replies “FIRE_”, along with the location (Figure 8).
- The master node alerting the base station “FIRE AT _” (Figure 9).

Hardware results

The master node receives data about smoke or fire from slave node, every few seconds. MAC protocol called polling is being used. The master node also checks if there is smoke or fire near its module:

- When there is fire at master node, the buzzer buzzes and the LCD display shows “FIRE ALERT1”. And an SMS is sent to the registered phone number (Figure 10).

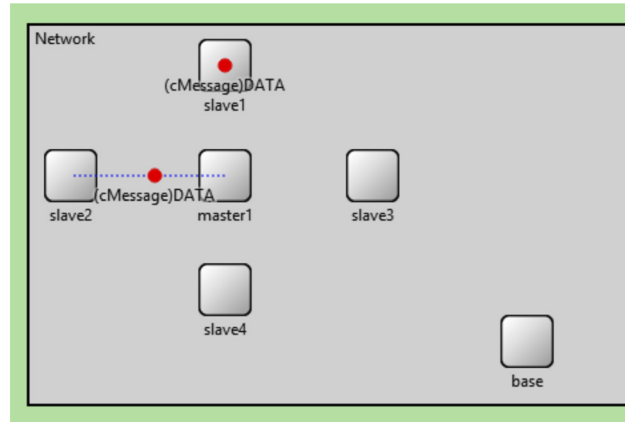

Figure 7: Master node polling.

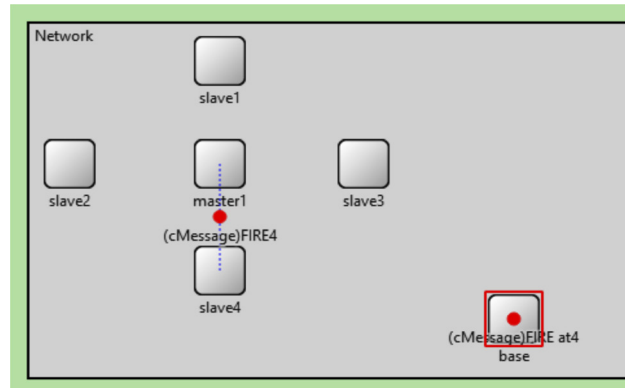

Figure 8: Slave node replying.

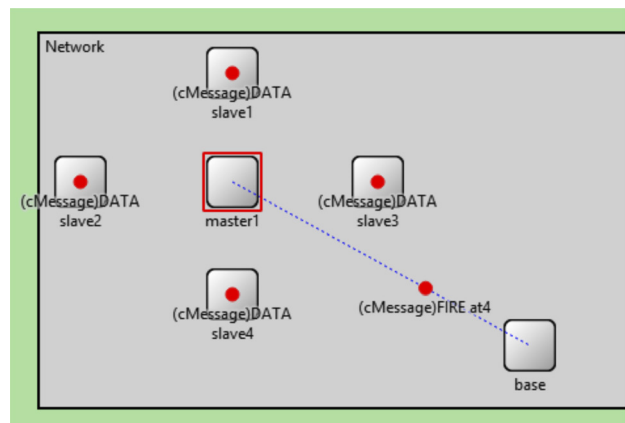

Figure 9: Master node alerting base.



Figure 10: LCD display: FIRE ALERT1.

- When there is fire at slave node, the buzzer buzzes and the LCD display shows “FIRE ALERT2”. And an SMS is sent to the registered phone number (Figure 11).

Similarly when there is smoke, the LED displays “Smoke Alert1” and “Smoke Alert2.”

Figure 12 shows the messages received at the base station.

The location of the nodes must be noted after deployment as there is no GPS. Fire retardant materials such as concrete, gypsum, asbestos, glass can be used to encase the nodes as protection mechanism. Glass is easily available and can withstand 1,000°C depending on the composition, so it can be used as a protective case. The case can also be placed underground with only the sensors protruding outside for increased safety of the components.

Conclusion and future scope

It is easier to suppress a fire in its starting stage than in the later stages. Hence, the most important goal is



Figure 11: LCD display: FIRE ALERT2.

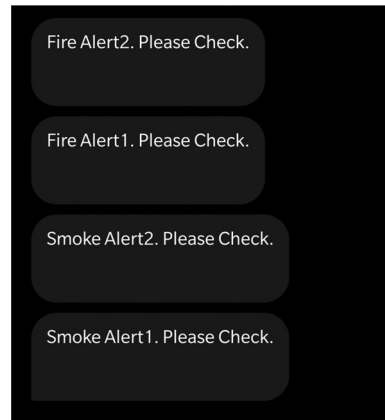

Figure 12: Base station messages.

quick, reliable detection and localization of the fire. The proposed fire alert system overcomes the need of a human intervention to continuously monitor the forest area. Monitoring and detecting is done by the sensors installed and message alerts are used to alert the required authorities. It gives instantaneous information on location of the fire to the authorities and help block the fire before it reaches cultural heritage sites.

This fire alert system is power efficient, low cost and low maintenance, and the equipment is durable and reliable. In future, we can install a wind sensor to the system which helps to determine the direction of the fire and the rate at which it will spread. Along with this we can implement an automatic fire extinguisher system. As soon as a sensor detects fire, extinguisher gets activated. GPS module can be added to the nodes to get the exact location of fire or smoke. By adding IOT, the data can be sent to cloud databases for storage and prediction purposes. In addition to these, many other sensors can also be implemented as per user requirement.

Literature Cited

- Alahi, M. E., Mukhopadhyay, S. C. and Burkitt, L. 2018. Imprinted polymer coated impedimetric nitrate sensor for real-time water quality monitoring. *Sensors and Actuators B: Chemical* 259: 753–761.
- Alahi, M. E., Xie, L., Mukhopadhyay, S. and Burkitt, L. 2017. A temperature compensated smart nitrate-sensor for agricultural industry. *IEEE Transactions on Industrial Electronics* 64(9): 7333–7341.
- Alahi, M. E., Pereira-Ishak, N., Mukhopadhyay, S. C. and Burkitt, L. 2018. An internet-of-things enabled smart sensing system for nitrate monitoring. *IEEE Internet of Things Journal* 5(6): 4409–4417.

- Arun Ganesh, U., Anand, M., Arun, S., Dinesh, M., Gunaseelan, P. and Karthik, R. 2013. Forest fire detection using optimized solar-powered zigbee wireless sensor networks. *International Journal of Scientific & Engineering Research* 4(6): 586–596.
- Basu, M. T., Karthik, R., Mahitha, J. and Reddy, V. L. 2018. IoT based forest fire detection system. *International Journal of Engineering & Technology* 7: 124–126.
- Demin, G., Haifeng, L., Anna, J. and Guoxin, W. 2014. A forest fire prediction system based on rechargeable wireless sensor networks. Proceeding of Network Infrastructure and Digital Content (IC-NIDC), 2014 4th IEEE International Conference, pp. 405–408.
- Hariyawan, M. Y., Gunawan, A. and Putra, E. H. 2013. Wireless sensor network for forest fire detection. *Telkomnika* 11(3): 563.
- Kumar, S. A., Ansari, M. F. R., Siddiqui, M. F. and Baig, M. A. 2017. IOT enabled forest fire detection and online monitoring system. *International Journal of Current Trends in Engineering and Research (IJCTER)* 3(5): 50–54.
- Othman, M. F. and Shazali, K. 2012. Wireless sensor network applications: a study in environment monitoring system. *Procedia Engineering* 41: 1204–1210.
- Pirbhulal, S., Zhang, H., Alahi, M. E., Ghayvat, H., Mukhopadhyay, S., Zhang, Y.-T. and Wu, W. 2017. A novel secure IoT-based smart home automation system using a wireless sensor network”. *Sensors* 17(1): 69.
- Singh, H. 2016. Forest fire detection using wireless sensor. *International Journal of Scientific Engineering Research* 7: 554–562.
- Singh, D., Sharma, N., Gupta, M. and Sharma, S. 2017. Development of system for early fire detection using Arduino UNO. *International Journal of Engineering Science* 10857–10860.
- Solobera, J. 2010. Detecting forest fire using wireless sensor networks, available at: http://www.libelium.com/wireless_sensor_networks_to_detect_forest_fires/ (accessed September 4).
- Stipaničev, D., Vuko, T., Krstinić, D., Štula, M. and Bodrožić, L. 2006. Forest fire protection by advanced video detection system-Croatian experiences. Third TIEMS Workshop-Improvement of Disaster Management Systems-Local and Global Trends.
- Tikhe, C. and Rail, N. 2018. Solar powered wireless forest fire detection. *International Journal of Advanced Research in Computer and Communication Engineering* 7(4): 80–83.
- Zhang, J., Li, W., Yin, Z., Liu, S. and Guo, X. 2009. Forest fire detection system based on wireless sensor network. 4th IEEE Conference on Industrial Electronics and Applications, Xi'an, 1: 520–523.