

Magneto-optical study of microwire in presence of magnetic field of super high frequency

Glass Coated Microwires for Sensor Application

Alexander Chizhik, Julian Gonzalez
 Dept. Material Physics, Chemistry Faculty
 University of Basque Country, UPV/EHU
 San Sebastián, Spain
 oleksandr.chyzyk@ehu.es

Arcady Zhukov
 Ikerbasque Science Foundation
 Bilbao, and Dept. Material Physics, Chemistry Faculty
 University of Basque Country, UPV/EHU
 San Sebastián, Spain

Andrzej Stupakiewicz, Andrzej Maziewski
 Laboratory of Magnetism
 University of Białystok
 Białystok, Poland

Abstract— The work is dedicated to the magneto-optical Kerr effect (MOKE) study of the magnetization reversal in the microwire in the presence of super high frequency (SHF) circular magnetic field. This study is important for elucidation of functioning of sensor based on giant magneto-impedance (GMI) effect. Magnetic domains images have been obtained using MOKE polarizing microscopy. Hysteresis loops were obtained as a result of images processing. It was found that SHF magnetic field induces strong change of the mechanism of magnetization reversal.

Keywords: *amorphous magnetic wire, hysteresis, magneto-optic Kerr effect, super high frequency*

I. INTRODUCTION

Application of glass covered microwires in high frequency sensors has reached now the competitive industrial level. The sensor based on the GMI effect is the part of the modern electronics. A number of magnetic sensors based on stress-impedance effect and giant magneto-impedance (GMI) effect with features comparable with conventional magnetic sensors have been reported [1, 2]. Main applications are related to the detection of the small weights, vibrations and magnetic fields. Such branches of the industry as the medicine, communication and car industry and are main consumers of these sensors. The following sensors are currently in progress: portable secondary current sensor for the induction motor control, digital display of the terrestrial magnetic field, car passing measurement brain tumour sensor, mechano-encephalogram sensor, fingertip blood vessel pulsation.

Stress-tuneable and temperature-tuneable composite materials based on ferromagnetic microwires with the effective microwave permittivity depending on an external magnetic field, applied stress or temperature recently have been discovered [3, 4]. These composites consist of pieces of conductive ferromagnetic wires introduced into a dielectric matrix. The short microwires work as elementary scatterers when the electromagnetic wave irradiates the composite. For a ferromagnetic conductive wire the surface impedance depends

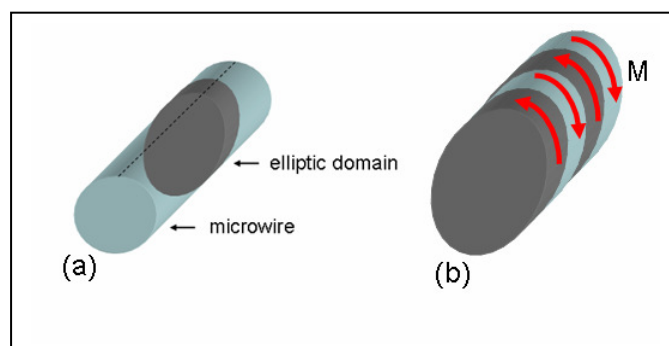

Figure 1. (a) Elliptic domain in microwire; (b) Direction of magnetization in elliptic multi-domains structure.

not only on the conductivity but also on the external magnetic field and tension because of the magneto-impedance effect. When magnetic field or tensile stress is applied to the composite the effective permeability can be tuned from a resonance type to a relaxation type.

The microwires application requests the increase of the sensors sensitivity and stable functioning. Earlier we have established the strong correlation between the GMI effect and the surface magnetic structure in the glass covered microwires [5]. Although we have reached the great understanding of the process of the surface magnetization reversal in the microwires with negative magnetostriction, the behavior of the magnetic system in the presence of electric current of super high frequency is not clear. The coexistence of the cylindrical shape and magnetoelastic anisotropy in ferromagnetic microwires causes a large variety of magnetic structures [6-9]. Consequently, the magnetic domain structure of microwires consists of axially magnetized inner core surrounded by outer domain shell with helical or radial magnetization direction [10]. Now we understand that the surface magnetic system could be presented as helically magnetized mono- or multi-domain structure (Fig. 1). Elliptic or serpentine domains are

two basic types of this domain structure [11]. The present paper is devoted to the study of the magnetization reversal in the presence of electric current of high and super-high frequency. The investigations have been performed using the magneto-optical Kerr effect technique which demonstrated very high efficiency in the study of the surface magnetic properties of cylindrically shaped samples [12].

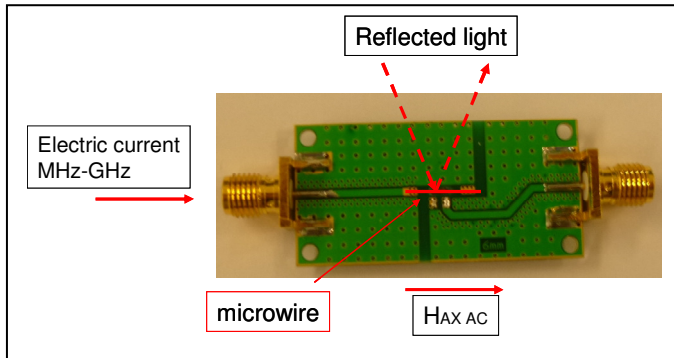

Figure 2. Sample cell.

II. EXPERIMENTAL DETAILS

The process of magnetization reversal in the surface area of the microwires has been studied by a MOKE technique. Usually the transverse and longitudinal configurations of MOKE have been used. The polarized light of a He-Ne laser was reflected from the microwire to the detector. The beam diameter was 0.8 mm. For the transverse configuration of MOKE, the intensity of the reflected light was proportional to the magnetization, which was perpendicular to the plane of incident light. A specific feature here is a nonplanar surface of microwire. The light reflected from a cylindrical surface of the microwire forms a conic surface.

There are two basic techniques to study the domain structure in the surface of microwire: Bitter technique [13, 14] and MOKE microscopy. The advantage of the MOKE method is the following: the application of the MOKE technique provides the unique possibility to obtain the information about the different projections of the magnetization in response to a combination of axial and circular magnetic fields.

The surface magnetic domains could be observed basically because of different in-plane components of the surface magnetization that transforms to black-white contrast when the polarized light reflects from the top of the cylindrically shaped surface of the microwire. We studied glass-coated microwire with the nominal composition $\text{Co}_{67}\text{Fe}_{3.85}\text{Ni}_{1.45}\text{B}_{11.5}\text{Si}_{14.5}\text{Mo}_{1.7}$ (metallic nucleus radius is 11.2 μm). To apply high frequency electric current of MHz-GHz band the microwire was soldered in a specially designed micro-strip cell (Fig. 2). The skin depth can be estimated as about 1 μm for a frequency of 100 MHz [16].

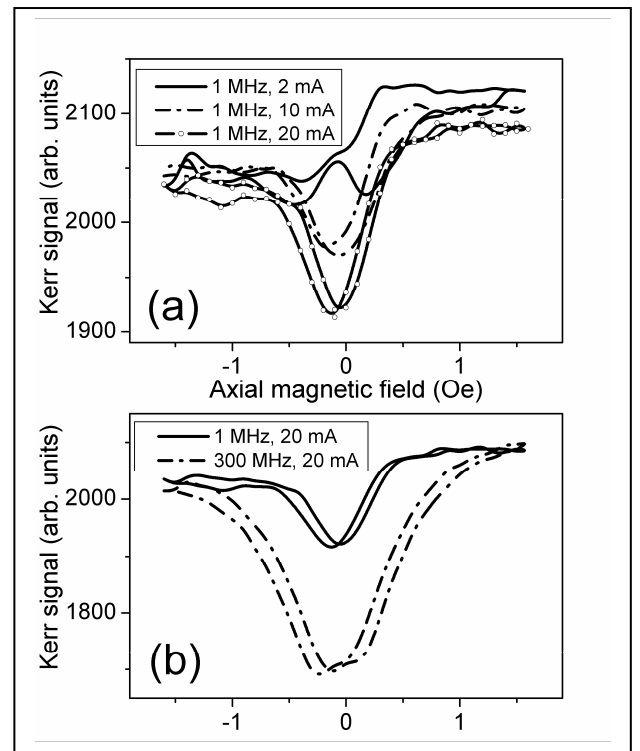

Figure 3. MOKE hysteresis loops in the presence of HF electric current: (a) 1 MHz for different current amplitudes; (b) comparison of hysteresis loops for 1 MHz and 300 MHz.

III. EXPERIMENTAL RESULTS AND DISCUSSION

Fig. 3 presents the MOKE hysteresis loops obtained in the axial magnetic field and in the presence of high frequency (HF) electric current (circular magnetic field) of MHz range. It is possible to appreciate strong transformation of the hysteresis loop with circular magnetic field that reflects considerable change of the magnetization reversal process.

When the circular magnetic field is small enough (2mA, Fig. 3(a)) the hysteresis consists of the rotation of the magnetization and the surface domain structure transformation. The circular magnetic field of 28 A/m corresponds to the electric current of 2 mA. The increase of the amplitude of the high frequency circular magnetic field (10 mA) causes asymmetric transformation of hysteresis loop. The following increase of the amplitude of the circular magnetic field amplitude (20 mA) induces the change of the remagnetization mechanism – the rotation of the magnetization dominates. Although the shape of this hysteresis is very similar to the shape of the hysteresis loop obtained in the presence of the DC circular magnetic field [15], the mechanism of the magnetization reversal is totally different.

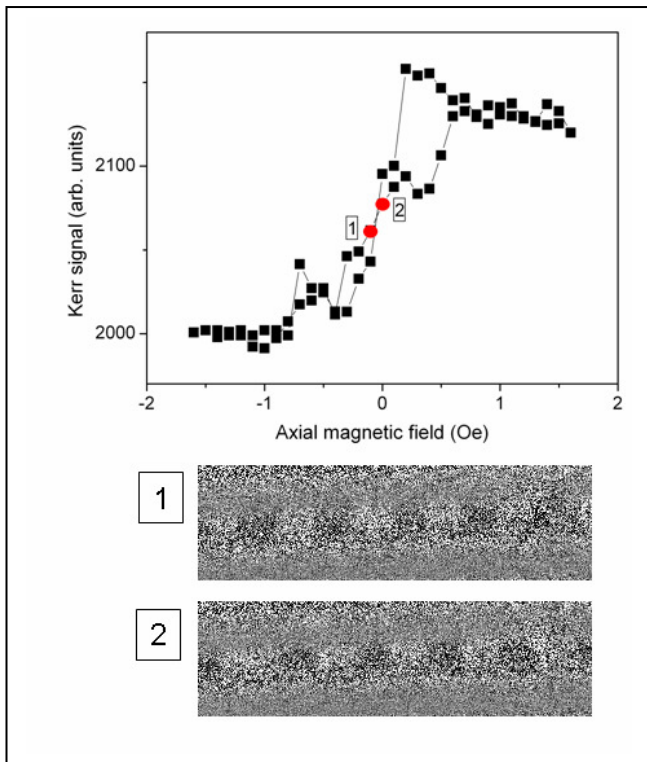

Figure 4. Hysteresis loop and domain images obtained in the presence of electric current of frequency of 0.1 GHz and amplitude of 2 mA.

The mechanism becomes clearer when the current of 300 MHz is applied (Fig. 3(b)). The increase of the frequency causes the increase of the inclination of the surface magnetization from the axial direction.

In difference from DC circular field, HF circular field induces the vibration of the surface magnetization. The vibration is followed by the successive inclination of magnetization towards the circular direction. As we can see (Fig. 3(b)) the degree of the inclination depends on the value of the frequency. The HF field stabilizes the inclined metastable helical structure.

Another effect which has been found we present in the Fig. 4. This effect must be attributed to the sharp change of the domain structure in the presence of HF magnetic field. The hysteresis loop has been obtained in the presence of the HF electric current of the frequency of 0.1 GHz and of the amplitude of 2 mA. The key moment of the magnetization reversal is marked as “1” and “2” in the figure. Two images of the surface domain structure which correspond to these points are also presented in Fig. 4.

These images demonstrate that the HF field induced jump-like change of the contrast of the surface domains: “black” domains changed to “white” domains and vice versa. This type of the magnetization reversal differs from the magnetization reversal which has been observed without HF field [17]. Earlier the transformation of the multi-domains structure was accompanied by the multiple domain walls displacements and now we have found that the HF field of small amplitude induces the jump of the direction of the magnetization inside of the domains. The important details of this process are small vibration of the surface magnetization

and relatively small value of the axial magnetic field. Normally this type of vibration of surface magnetization induces the nucleation of domains. In the present experiment when the axial magnetic field changes the sign from negative to positive, the unusual type of the mechanism of the magnetization reversal is observed: the domain wall motion is suppressed and the magnetization changes sharply in the existing domains.

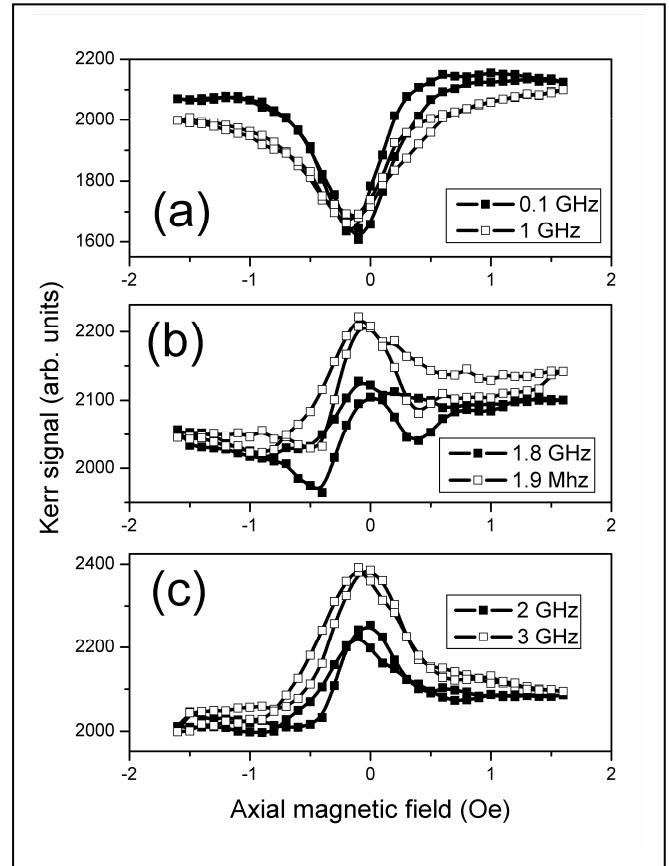

Figure 5. MOKE hysteresis loops obtained in the presence of SHF electric current of 20 mA: (a) 0.1 GHz and 1 GHz; (b) 1.8 GHz and 1.9 GHz; (c) 2 GHz and 3 GHz.

The last experiment which we have performed for the elucidation of the mechanism of the magnetization reversal is presented in the Fig. 5. The MOKE hysteresis loops have been obtained in the presence of SHF electric current of 20 mA amplitude and frequency band of 0.1 GHz – 3 GHz.

Fig. 5(a) presents the hysteresis loops measure in the presence of SHF electric current of 0.1 GHz and 1 GHz. The shape of the presented curves could be interpreted in the following way: the SHF circular magnetic field makes one of the surface circular domains as an advantageous state. The rotation of the magnetization in this domain is observed. The increase of the frequency from 0.1 GHz to 1 GHz does not change the mechanism of the magnetization reversal but accelerates the rotation of the magnetization. The circular field of 1 GHz induces higher inclination of the circular magnetization toward the circular direction that causes the observed acceleration.

The Fig. 5(b) presents enough unexpected effect. For the short band of the frequency (1.8 GHz - 1.9 GHz) the strong transformation of the hysteresis loop takes place. For the frequency of 1.8 GHz the MOKE hysteresis consists of the parts which could be clearly interpreted as a transformation of surface domain structure. For the frequency of 1.9 GHz the almost pure rotation of the magnetization is observed, but the direction of the rotation differs from the case of 1 GHz: now the other circular domain is the advantageous one. This effect could be explained in supposition of the existence of small initial helicality of surface magnetic structure. The increase of the amplitude of the vibration of the magnetization is induced by SHF field. When the vibrating circular magnetization overcomes the axial direction of the microwire the meta-stable advantageous domain change the sign to the opposite one.

For the frequency of 3 GHz we also observe the pure rotation of the magnetization (Fig. 5(c)). The magnetic field of 3 GHz makes more inclined helical surface magnetic domain as a meta-stable state. The higher amplitude for the hysteresis in small axial field is the result of this effect of inclination. Generally the effect observed in this frequency band could be interpreted in the frame of low field absorption and splitting between giant magnetoimpedance and ferromagnetic resonance [18].

IV. CONCLUSIONS

The magneto-optical study of the magnetization reversal has been performed in the presence of MHz-GHz electric current in the microwire with GMI effect. The series of the original effects has been found. The SHF circular magnetic field induces the existence of the meta-stable inclined helical state. The degree of the helicality and the sign of the meta-stable states depend on the frequency and the amplitude of the SHF field. Also the unusual mechanism of the magnetization reversal has been observed: direction of the magnetization changes sharply in the existing domains in the presence of low circular field.

ACKNOWLEDGMENT

This work was supported by Spanish Ministry of Science and Innovation, MICINN under Project MAT2010 - 18914, by the Basque Government under SAIOTEK - 2012 MEMFOMAG (S - PE12UN139) Saiotek - 2013 PROMAGMI (S - PE13UN014), DURADMAG (S - PE13UN007) projects. Technical and human support provided by SGIker (UPV/EHU, MICINN, GV/EJ, ERDF and ESF) is gratefully acknowledged.

REFERENCES

- [1] Y. Honkura, in "Advanced Magnetic Materials for Technological Applications," pp 71-94, Editors: Arcady Zhukov and Julian Gonzalez, Transworld Research Network, 2008.
- [2] T. Kanno, K. Mohri, T. Yagi, T. Uchiyama, L. P. Shen, L.P. "Amorphous wire MI micro sensor using CMOS IC multivibrator," IEEE Trans.Magn., vol. 33, 1997, pp. 3358-3360, 1997.
- [3] D. P. Makhnovskiy, L. V. Panina, and S. I. Sandacci, S. I., "Tuneable microwave composites based on ferromagnetic microwires," Book chapter in Progress in Ferromagnetism Research, Editor: V. N. Murray, ISBN: 1-59454-335-6, Nova Science Publishers Inc., USA, 2005.
- [4] L. Liu, L. B. Kong, G. Q. Lin, S. Matitsine, and C. R. Deng, "Microwave permeability of ferromagnetic microwires composites/metamaterials and potential applications," IEEE Trans. Magn., vol. 44, pp. 3119-3122, 2008.
- [5] M. Ipatov, A. Chizhik, V. Zhukova, J. Gonzalez and A. Zhukov, "Correlation of surface domain structure and magneto-impedance in amorphous microwires," Journal of Applied Physics, vol. 109, pp. 113924, 2011.
- [6] M. Vazquez, H. Chiriach, A. Zhukov, L. Panina, and T. Uchiyama, "On the state-of-the-art in magnetic microwires and expected trends for scientific and technological studies," Phys. Status Solidi A, vol. 208, pp. 493-501, 2011.
- [7] H. Chiriach, S. Corodeanu, M. Lostun, G. Ababei, and T.-A. Óvári, "Magnetic behavior of rapidly quenched submicron amorphous wires," J. Appl. Phys., vol. 107, pp. 09A301, 2010.
- [8] R. P. Erickson and D. L. Mills, "Theory of the undulating magnetic ground state of cylindrical cobalt nanowires," Phys. Rev. B, vol. 80, pp. 214410, 2009.
- [9] R. Varga, A. Zhukov, J.M. Blanco, M. Ipatov, V. Zhukova, J. Gonzalez and P. Vojtanik, "Fast magnetic domain wall in magnetic microwires," Phys. Rev. B, vol. 74, pp. 212405, 2006.
- [10] M. Ipatov, V. Zhukova, A. Zhukov, J. Gonzalez, and A. Zvezdin, "Low-field hysteresis in the magnetoimpedance of amorphous microwires," Phys. Rev. B, vol. 81, pp. 134421, 2010.
- [11] A.Chizhik, A. Stupakiewicz, A. Zhukov, A. Maziewski and J. Gonzalez, "Transformation of magnetic domain structure in Co- and Fe-rich amorphous microwires," accepted for publication in Journal of Alloys and Compounds, 2014.
- [12] A. Chizhik and J. Gonzalez "Magnetic Microwires. A Magneto-Optical Study", Pan Stanford Publishing, Singapore, 2014.
- [13] J. Santos, A. Ruiz, R. Cobos, I. Robot, V. Vega, P. Alvarez, M. L. Sanchez, J. L. Sanchez, V. Prida, and B.Hernando, "Domain wall dynamics in Fe-richglass covered amorphous microwires," Phys. Stat. Sol., vol. A 206, pp.618-621, 2009.
- [14] B. Hernando, M. L. Sánchez, V. M. Prida, J. D. Santos, J. Olivera, F. J. Belzunce, G. Badini, and M. Vázquez, "Magnetic domain structure of amorphous Fe_{73.5}Si_{13.5}B₉Nb₃Cu₁ wires under torsional stress," Journ. Appl. Phys., vol. 103, pp. 07E716, 2008.
- [15] A. Chizhik, A. Zhukov, J.M. Blanco and J. Gonzalez, "Magneto-optical investigation of the magnetization reversal in Co-rich wires," Physica B, vol. 299, pp. 314-321, 2001.
- [16] H. Lachowicz, M. Kuzminski, K.L. García, A. Zhukov and M. Vázquez, A. Krzyzewski, "Influence of Alternative circular magnetic field strength on magnetoimpedance of glass-coated micro-wire", J. Magn. Mater. Vol. 300 , pp e88-e-92, 2006 .
- [17] A. Chizhik, A. Stupakiewicz, A. Maziewski, A. Zhukov, J. Gonzalez and J. M. Blanco, "Direct observation of giant Barkhausen jumps in magnetic microwires," Applied Physics Letters, vol. 97, pp. 012502, 2010.
- [18] R. Valenzuela, R. Zamorano, G. Alvarez, M.P. Gutierrez and H. Montiel, "Magnetoimpedance, ferromagnetic resonance, and low field microwave absorption in amorphous ferromagnets," Journal of Non-Crystalline Solids, v. 353, pp.768-772, 2007.