

New approaches for improving selectivity and sensitivity of resistive gas sensors: A review

Janusz Smulko, Maciej Trawka
Faculty of Electronics, Telecommunications
and Informatics
Gdansk University of Technology
Gdańsk, Poland
jsmulko@eti.pg.gda.pl

Claes G. Granqvist
Department of Engineering Sciences
The Ångström Laboratory, Uppsala University
Uppsala, Sweden

Radu Ionescu, Fatima E. Annanouch, Eduard Llobet
ETSE-DEEEA, Department of Electronics
Rovira i Virgili University
Tarragona, Spain

Laszlo B. Kish
Department of Electrical Engineering
Texas A&M University
College Station, USA

Abstract — Resistive gas sensors are very popular and reliable but suffer from low selectivity and sensitivity. Various methods have been suggested to improve both features without increasing the number of sensors in gas detection systems. Fluctuation enhanced gas sensing was proposed to improve gas detection efficiency by analyzing low-frequency resistance fluctuations, and noise parameters can be more informative than the single DC resistance and can advance gas detection systems by improving detection and limiting energy consumption. Gas sensor temperature can be modulated as well to further increase selectivity and sensitivity. Finally, some gas sensing layers exhibit a photo-catalytic effect, which can be applied to improve detection and yield lower operating temperatures of the gas sensing materials.

Keywords: resistive gas sensors; noise; low-frequency fluctuations; gas sensing; detection methods

I. INTRODUCTION

Resistive gas sensors—also known as Taguchi gas sensors—are very popular as a consequence of their reasonable price and good durability [1]. However, their selectivity and sensitivity are limited, and these deficiencies serve as a main driving force to develop new materials and methods for superior gas detection. Taguchi gas sensors comprise a porous semiconductor layer (e.g., SnO_2 , WO_3 , TiO_2 , ZnO) which starts to be gas sensitive at elevated temperature, up to a few hundred °C (Fig. 1). This means that the sensors can be used to analyze even exhaust gases, but they have to consume energy for the heating. Therefore it is important to propose new methods, which are able to improve the state-of-the-art in gas sensing.

There are numerous papers focused on optimizing parameters of metal oxides in order to enhance their selectivity and sensitivity [2–7]. Thus it was established that a vital improvement can be reached via controlling the size and the shape of the gas sensor's oxide grains [2, 3] or by introducing catalytically active additives in the sensing layer via doping or surface functionalization [4–7]. The results of these improvements are still far from satisfactory, and therefore it is

of great interest to consider new methods for advancing gas detection.

Gas detection efficiency can be enhanced not only by technological development of the sensors but also by new measurement methods and signal processing. Recently, experimental studies confirmed that low-frequency, colored resistance fluctuations, generated within the gas sensors, can be utilized to improve their selectivity and sensitivity [8–12]. It is well known that $1/f$ noise is intense in porous materials and depends on their surface treatment [13, 14]. It is also clear that similar phenomena can be used to determine the ambient atmosphere for gas sensors. Low frequency noise can be characterized by various statistical functions (e.g., power spectral density or probability distribution); they are more informative than the DC resistance which gives nothing but an individual number for the sensor.

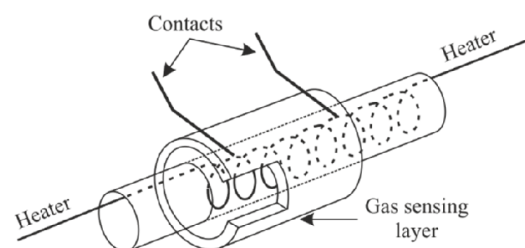

Figure 1. Structure of a resistive gas sensor

Another method, which can be easily implemented to improve gas detection, utilizes temperature modulation of the gas sensing layer. Processes connected with gas molecule adsorption and desorption depend on temperature and are responsible for the drop in sensitivity at low and high operating temperatures [15]. Competition between adsorption and desorption processes determines the temperature of maximum sensitivity and its decrease at temperature changes. This means that different temperature profiles should be observed for different gases and utilized for selectively recognizing them, as has been confirmed experimentally [16, 17]. Moreover, the

change of gas sensitivity versus temperature can be utilized to preserve information about ambient atmosphere within the gas sensor by its cooling in the investigated environment and “freezing” the gas molecules within the gas sensing layer for further analysis under laboratory conditions at elevated temperature. This technique is referred to as “sample-and-hold” and can be used together with fluctuation enhanced sensing [18].

Adsorption and desorption processes are accelerated when the gas sensing layer operates at elevated temperature, typically above 150°C. However, such conditions limit possible sensor applications and furthermore increase energy consumption.

There is experimental evidence that some gas sensing materials exhibit a photo-catalytic effect, and their sensitivity to various gases can be modulated by UV irradiation [17–21]. This effect has been observed, even at room temperature, and resulted in better sensitivity to the selected gases. We can expect that similar effects of UV irradiation can be observed for DC resistance and low-frequency noise as well. Preliminary experimental results confirmed the photo-catalytic effect for a very thin TiO₂ gas sensing layer, but its very high resistance limited practical applications [22]. Resistance noise induced by UV irradiation could potentially be a very sensitive tool, because the generated noise should be sensitive to the wavelength of the applied irradiation. Thus a combination of different wavelengths of the light sources could result in superior gas selectivity as compared with other methods.

The mentioned sensing methods can provide additional information about the ambient atmosphere of the gas sensor than what is possible with DC resistance only. This information has to be properly processed to get satisfactory detection results by applying various algorithms. Usually, different gases are detected by applying a sensor array (electronic nose) and processing array for DC resistances using pattern recognition methods [23–25]. We will present a number of selected detection methods which can guarantee that the gathered noise data and dynamic changes of the DC resistance at a temperature change limit the number of sensors necessary to record the selected gases.

II. FLUCTUATION-ENHANCED GAS SENSING

Resistive gas sensors exhibit an intense $1/f$ noise component, which overwhelms white noise up to tens of kHz at least. Low-frequency noise is generated by fluctuations of the potential barrier between the grains (Fig. 2). The barrier depends on adsorption and desorption processes, and therefore its fluctuations can be selective to the ambient atmosphere of the gas sensor and its temperature. There is experimental evidence that the $1/f$ noise increases when the grains are smaller. Additionally, noise changes are much more sensitive than changes in the DC resistance, and the sensitivity increases further when the grains of the investigated gas sensing layer decrease [9].

Low-frequency noise generated within the porous gas sensing layer can be observed as voltage or current fluctuations across/through the gas sensor biased by constant voltage U or current I in accordance with the Hooge formula [26]

$$\frac{S_u(f)}{U^2} = \frac{S_i(f)}{I^2} = \frac{\alpha}{fnV_{eff}}, \quad (1)$$

where $S_u(f)$ and $S_i(f)$ are power spectral densities of voltage and current fluctuations observed across/through the biased gas sensor, respectively, α is the Hooge parameter which depends on the material of the gas sensing layer and ambient atmosphere, n is the density of charge carriers involved in noise generation within the gas sensing layer, and V_{eff} is the effective noise volume of the sensor and determined by the grain boundary contacts. Thus to get information about the ambient atmosphere we have to estimate $S_u(f)/U^2$ or $S_i(f)/I^2$, which are independent of sensor bias. Fig. 3 shows examples of noise data observed in a commercial TGS 826 gas sensor. Typically, we observe $1/f$ noise whose intensity depends on the ambient atmosphere. Power spectral density can change by as much as a few orders of amplitude and is characteristic for the investigated gas and its concentration.

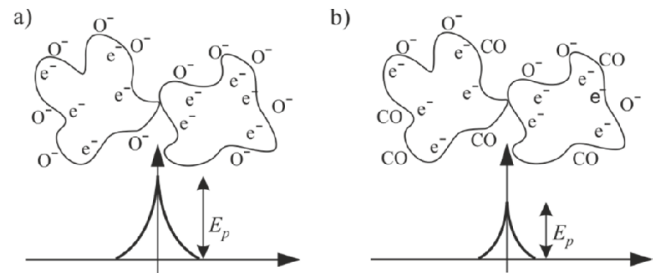

Figure 2. Influence of ambient atmosphere causing changes in the potential barrier E_p between the grains of the gas sensing layer: (a) in the presence of oxygen ions (O^-) and (b) displaced by carbon monoxide (CO) molecules

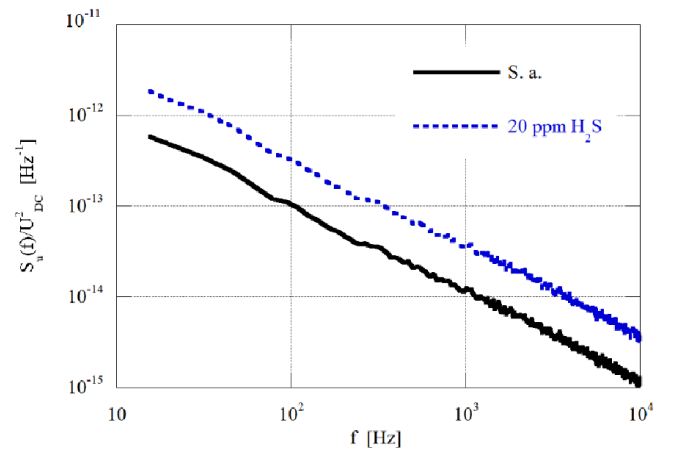

Figure 3. Power spectral density $S_u(f)$ of voltage fluctuations across a commercial TGS 826 gas sensor, normalized to the square of DC bias voltage U . Data were taken in an ambient atmosphere of hydrogen sulfide (H_2S) diluted in synthetic air (s.a.) at different concentrations. Noise is observed within a few decades of frequency f

The observed $1/f$ noise can give sufficient information to limit the number of sensors necessary to distinguish between the selected gases (e.g., ammonia and hydrogen sulfide [11]). When a single gas sensor is applied, and one observes its low-frequency noise and DC resistance by measuring the DC voltage across the sensor (Fig. 4), it is possible to determine gas concentration and detect gaseous species. The power

spectral density $S_u(f)$ observed at the output of the system depends on ambient gas by a change of the normalized spectrum $S_u(f)/U^2$ and on change of the sensor's DC resistance R_S independently according to

$$S_u(f) = \frac{S_u(f)}{U^2} U^2 = \frac{S_u(f)}{U^2} U_0^2 \left(\frac{R_s}{R_1 + R_s} \right)^2. \quad (2)$$

When the sensor exhibits various changes of $S_u(f)/U^2$ in different gases, one can establish the type of gas and the DC resistance determines its concentration. Fig. 5 presents data observed for two gases, ammonia and hydrogen sulfide, in the commercial gas sensor TGS 826 [11]. The presence of hydrogen sulfide increases the power spectral density whereas ammonia decreases it. Thus using a single sensor, one can detect which gas is present by estimating $S_u(f)$ within the selected bandwidth and determining its changes by comparing them with measurements in air.

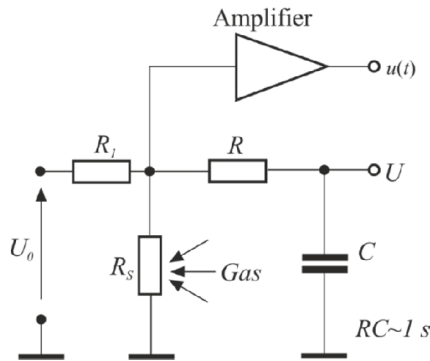

Figure 4. Measurement set-up for power spectral density $S_u(f)$ of voltage fluctuations $u(t)$ across a gas sensor having a DC resistance R_S and being biased by a DC voltage U

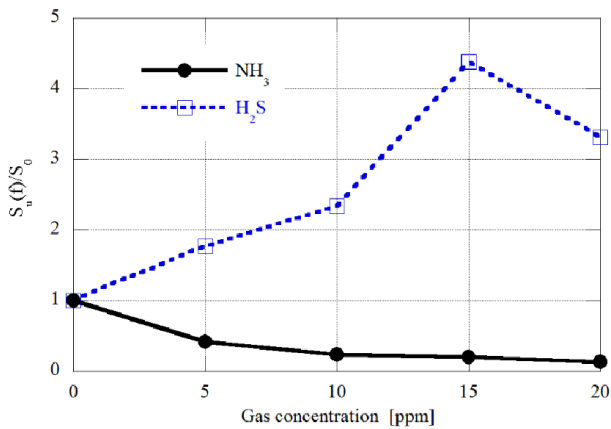

Figure 5. Normalized power spectral density $S_u(f)$ of voltage fluctuations across the sensor at 1kHz for a commercial TGS 826 sensor in various gases and concentrations. The sensor was placed in serial connection with a resistor $R_1 = 11 \text{ k}\Omega$ and biased by a stabilized voltage source U_0 (cf. Fig. 4)

Other methods for gas detection by use of fluctuation enhanced gas sensing require more advanced statistical parameters in order to expose a non-Gaussian component, characteristic for various gases [27]. A bispectrum function can measure the intensity of that component but requires more data

to be estimated than those needed for the power spectral density. Cross-level images of the bispectrum can be used to determine the presence of different gases [28]. There is evidence that the non-Gaussian component is more intense with gas sensors comprising smaller grains [29]. The bispectrum function is often much more informative than the power spectral density only, but the requirements of longer averaging time and slower noise sampling limit its practical application.

III. GAS SENSOR TEMPERATURE MODULATION

Features of resistive gas sensors depend strongly on their working temperature, and this fact can be used to gather more information about the ambient atmosphere in order to improve sensitivity and selectivity. Typically, one can use pulse heating to clean the gas sensing layer by removing adsorbed molecules. When the intensity of the heating pulse is carefully selected, one can observe dynamic changes of the DC resistance R_S with a characteristic shape determined by the composition of the ambient atmosphere (Fig. 6). It should be underlined that the drop of the heating voltage from 5 to 4.7 V results in a significant change of the DC resistance but almost no change of $S_u(f)/U^2$. Thus, in order to improve gas detection one should consider the shape of the DC resistance changes, or selected parameters describing them, such as maximum and derivative at rise and drop. Results analogous to those in Fig. 6 were observed when the heating voltage was increased; then the DC resistance dropped and exhibited a local minimum mirroring the shape of the time dependence shown in Fig. 6. Time constants of the DC resistance modulation depend on the gas sensors, their ambient atmosphere, and the temperature alteration. Thus in some prototype gas sensors with very thin gas sensing layers, one can observe a much stronger change of the DC resistance and absence of a peak structure (Fig. 7), which is a consequence of a smaller thermal inertia than for the commercial sensor (Fig. 6) with much greater volume (Fig. 1).

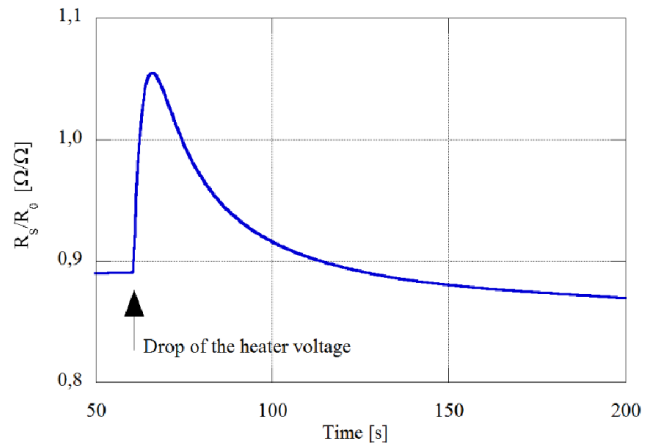

Figure 6. Time-dependent gas sensor DC resistance R_S at an abrupt drop of the heating voltage from 5 to 4.7 V. The commercial gas sensor (TGS 2600) was placed in an ambient atmosphere of combustible gases (C_2H_6 , C_3H_8 , $n\text{-C}_4\text{H}_{10}$, C_4H_{10}). R_S was normalized to the sensor's DC resistance R_0 observed in synthetic air

It is worth mentioning that temperature modulation can lead to very interesting and new applications when the heated gas

sensor is exposed to an unknown gas mixture and subsequently cooled. The gas molecules will then be trapped inside the porous gas sensing layer as a result of a less intense adsorption/desorption processes and preserved for further analysis under laboratory conditions [18]. Moreover, one can expect that resistance noise in the gas sensing structure could be observed and used for gas detection even at temperatures lower than those typically employed for the gas sensor. This means that various temperatures could be applied to establish an adsorption–desorption profile of the explored atmosphere and providing improved gas detection.

IV. LIGHT-INDUCED GAS SENSING

Light activation for gas sensing applications has been reported for various oxide layers (e.g., ZnO, WO₃, SnO₂, TiO₂) [19–22]. UV light is applied to assure sufficient energy for acceleration of adsorption/desorption processes. Usually the same effect can be obtained by heating the gas sensing layer. This means that the use of UV light results in lower energy consumption and ability to work at much lower temperatures. The second fact opens new applications for resistive gas sensors (e.g., detection of combustible gases or explosives). Additionally one can expect that UV light reduces measurement time and can be used to clean gas sensors after poisoning [19].

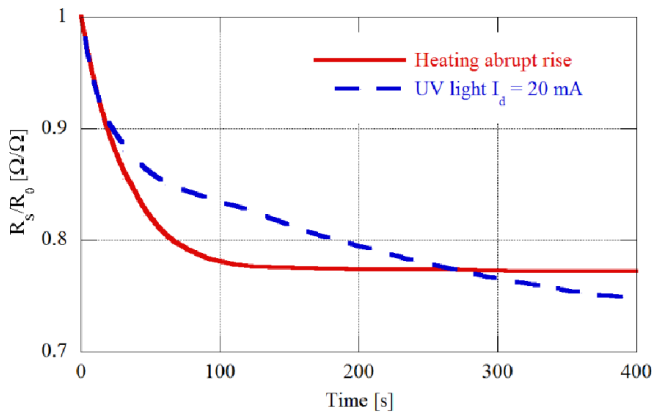

Figure 7. Relative change of DC resistance R_S for a WO₃ gas sensing layer at an abrupt rise of the heating voltage from 1.5 to 1.8 V, corresponding to a temperature change between 100 and 120°C (solid curve), and by UV irradiation (dashed curve). R_0 denotes resistance in synthetic air and at a heating voltage of 1.5 V, and I_d is the UV diode current

Examples of data recorded with an Au-nanoparticle-decorated WO₃-nanowire gas sensing layer are presented in Fig. 7 [30], which compares the change of the sensor’s DC resistance, induced by an abrupt increase of the heating voltage, with that caused by UV irradiation using a T5F UV diode emitting radiation at a wavelength of 365 nm. The diode was placed about 5 mm from the surface of the sensor layer, and its DC current I_d was controlled up to a maximum value of 20 mA.

One can conclude that additional data on the ambient atmosphere can result from the application of an abrupt temperature change as well as from UV irradiation. The shape of the recorded curve depends on the sensor’s ambient

atmosphere, as was observed for synthetic air (Fig. 7) and ethanol (Fig. 8). Data collected by using UV light and temperature modulation are rather similar, at least for the presented results, but it should be underscored that UV light yields a lower energy consumption than that necessary for temperature modulation (the effect on the sensor’s DC resistance change can be observed even at low diode currents I_d ; cf. Fig. 8). Additionally, using UV light one can detect gases at much lower temperatures, which is a very attractive feature. One can expect that UV irradiation will increase the usefulness of fluctuation enhanced sensing, because $1/f$ noise might depend strongly on the wavelength of the applied UV light and therefore should provide more information about the ambient gas than temperature modulation alone.

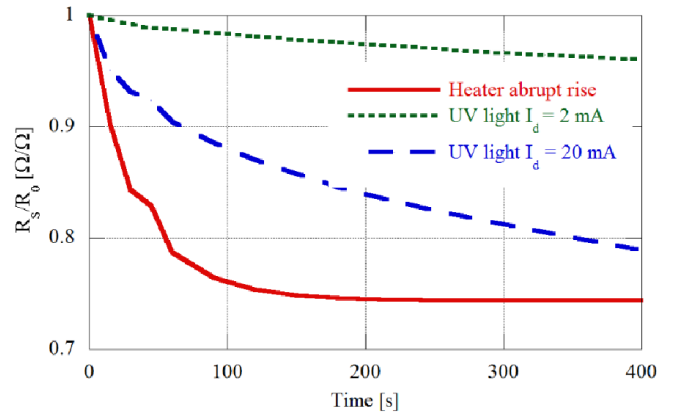

Figure 8. Relative change of DC resistance R_S for a WO₃ gas sensing layer at an abrupt rise of the heating voltage from 1.5 to 1.8 V, corresponding to a temperature change between 100 and 120°C (solid line), and by UV irradiation at the shown values of the UV LED current. Data were taken in 200 ppm of ethanol. R_0 denotes resistance in 200 ppm of ethanol at a heating voltage of 1.5 V

V. DETECTION ALGORITHMS

This paper has demonstrated that gas sensing can be improved by very simple methods in some cases, and different gases can be detected by a single gas sensor by use of noise measurements (cf. Fig. 5). In general, the same detection algorithms can be used for gas sensing as for other detection methods (e.g., chemometric techniques [31]) when the input data are vectors. A set of DC resistances, power spectral density of voltage fluctuations across the sensor (Fig. 3), and dynamic change of DC resistance in selected time intervals (Fig. 6) can be treated as vectors. Such data can be analyzed by principal component analysis (PCA), which utilizes linear and orthogonal data transformation into a new set of linearly uncorrelated variables, referred to as “principal components”. This method requires algebraic computations to perform the necessary transforms in order to establish the most informative components. The method is commonly used in gas sensing applications for gas detection or for gas concentration prediction. A more advanced method employs a support vector machine (SVM) algorithm, which is a nonlinear version of the PCA [23, 24]. The latter method gives even better results, because gas sensors respond to various gases in a nonlinear manner. Both PCA and SVM can be applied to detect the presence of the selected gases which exceed threshold

concentrations and to establish their concentration using a regression model.

The data used for gas detection (e.g., power spectral density) are vectors whose adjoining elements are correlated, and therefore methods such as PCA or SVM have to reduce abundant data. Therefore other methods, which might have similar detection efficiency but require much less intense computations, can be of interest. Such methods use selected parameters of the estimated functions. In the case of power spectral density, one can use its intensity and slope within the selected bandwidth [32]. This method requires limited computation and can create a reduced set of data for further processing by a more computationally demanding method, e.g., an SVM algorithm [33].

In general, the algorithms have to be adjusted for the case when a few volatile components have to be detected and additionally some specific substances exist in the ambient atmosphere and conceal the effects caused by the chemicals of interest. A good example is identification of chemical compounds in human breath, which can be characteristic for some diseases [34].

VI. CONCLUSIONS

Various methods for improving selectivity and sensitivity of resistive gas sensors were presented. The proposed methods can be applied to prepare more advanced measurement set-ups than those commonly used today. The same techniques can also be used to improve new gas sensing materials. The combined method of fluctuation enhanced sensing and UV light modulation might be the most promising method to reach maximum sensitivity and selectivity at limited cost, as also supposed by other authors [35].

TABLE I. PROS AND CONS OF THE CONSIDERED GAS SENSING METHODS

Method	Advantages	Disadvantages
Resistance	Easy measurements; can be modulated by temperature change or UV light when photocatalysis is present.	Gives a single number only; requires additional sensors to detect composition of gas mixtures.
Fluctuation enhanced sensing	Up to a few hundred times more sensitive than DC resistance; gives reduction of consumed energy.	More complicated measurements and estimation method; longer averaging time.

It is difficult to compare efficiency of fluctuation enhanced sensing with gas detection using DC resistance measurements only because both methods establish different information about the sensor's ambient atmosphere. The main features for comparing both methods are collected in table 1. We can conclude in general that fluctuation enhanced sensing is more sensitive and gives additional information when compared with DC resistance measurements only. Additionally, differences between the methods are more visible when the sensors are comprised of very small grains. Then the gas sensors respond to the gas changes in a faster way, and $1/f$ noise predominates even up to tens of kHz [9, 29, 36].

The presented new approaches to gas sensing using resistance sensors should facilitate the introduction of new

applications by enabling gas detection at different temperatures than previously assumed or determining composition of the gas mixture at a reduced number of the applied sensors.

ACKNOWLEDGMENT

This research was partially financed by the Polish Ministry of Science, project No. UMO-2012/06/M/ST7/00444 "Detection of gases by means of nanotechnological resistance sensors". CGG's work was supported by the European Research Council under the European Community's Seventh Framework Program (FP7/2007–2013)/ERC Grant Agreement No. 267234 ("GRINDOOR").

REFERENCES

- [1] G. Sberveglieri, "Recent developments in semiconducting thin-film gas sensors," *Sensors and Actuators B: Chemical*, vol. 23, 1995, pp. 103–109.
- [2] G.-J. Li, X.-H. Zhang, S. Kawi, "Relationships between sensitivity, catalytic activity, and surface areas of SnO₂ gas sensors," *Sensors and Actuators B: Chemical*, vol. 60, 1999, pp. 64–70.
- [3] M. E. Franke, T. J. Koplín, U. Simon, "Metal and metal oxide nanoparticles in chemiresistors: Does the nanoscale matter?" *Small*, vol. 2, 2006, pp. 36–50.
- [4] G. Korotcenkov, "Gas response control through structural and chemical modifications of metal oxide films: State of the art and approaches," *Sensors and Actuators B: Chemical*, vol. 107, 2005, pp. 209–232.
- [5] T. Hyodo, S. Abe, Y. Shimizu, M. Egashira, "Gas-sensing properties of ordered mesoporous SnO₂ and effects of coatings thereof," *Sensors and Actuators B: Chemical*, vol. 93, 2003, pp. 590–600.
- [6] N. Yamazoe, Y. Kurokawa, T. Selyama, "Effects of additives on semiconductor gas sensors," *Sensors and Actuators*, vol. 4, 1983, pp. 283–289.
- [7] P. Heszler, R. Ionescu, E. Llobet, L. F. Reyes, J. Smulko, et al., "On the selectivity of nanostructured semiconductor gas sensors," *Physica Status Solidi B*, vol. 244, 2007, pp. 4331–4335.
- [8] L. B. Kish, R. Vajtai, C. G. Granqvist, "Extracting information from noise spectra of chemical sensors: Single sensor electronic noses and tongues," *Sensors and Actuators B: Chemical*, vol. 71, 2000, pp. 55–59.
- [9] J. Ederth, J. Smulko, L. B. Kish, P. Heszler, C. G. Granqvist, "Comparison of classical and fluctuation-enhanced gas sensing with Pd₂WO₃ nanoparticle films," *Sensors and Actuators B: Chemical*, vol. 113, 2006, pp. 310–315.
- [10] M. Kotarski, J. Smulko, "Noise measurement setups for fluctuations enhanced gas sensing," *Metrology and Measurement Systems*, vol. 16, 2009, pp. 457–464.
- [11] M. Kotarski, J. Smulko, "Hazardous gases detection by fluctuation-enhanced gas sensing," *Fluctuation and Noise Letters*, vol. 9, 2010, pp. 359–371.
- [12] A. K. Vidybida, "Adsorption-desorption noise can be used for improving selectivity," *Sensors and Actuators A: Physical*, vol. 107, 2003, pp. 233–237.
- [13] A. W. Stadler, Z. Zawiślak, A. Dziejczak, D. Nowak, "Noise spectroscopy of resistive components at elevated temperature," *Metrology and Measurement Systems*, vol. 21, 2014, pp. 15–26.
- [14] C. G. Granqvist, S. Green, E. K. Jonson, R. Marsal, G. A. Niklasson, et al., "Electrochromic foil-based devices: Optical transmittance and modulation range, effect of ultraviolet irradiation, and quality assessment by $1/f$ current noise," *Thin Solid Films*, vol. 516, 2008, pp. 5921–5926.
- [15] S. R. Morrison, "Selectivity in semiconductor gas sensors," *Sensors and Actuators*, vol. 12, 1987, pp. 425–440.

- [16] N. Yamazoe, K. Shimanoe, "Theoretical approach to the gas response of oxide semiconductor film devices under control of gas diffusion and reaction effects," *Sensors and Actuators B: Chemical*, vol. 154, 2011, pp. 277–282.
- [17] N. P. Zaretskyi, L. I. Menshikov, A. A. Vasiliev, "On the origin of sensing properties of the nanostructured layers of semiconducting metal oxide materials," *Sensors and Actuators B: Chemical*, vol. 170, 2012, pp. 148–157.
- [18] B. Ayhan, C. Kwan, J. Zhou, L. B. Kish, K. D. Benkstein, et al., "Fluctuation enhanced sensing (FES) with a nanostructured, semiconducting metal oxide film for gas detection and classification," *Sensors and Actuators B: Chemical*, vol. 188, 2013, pp. 651–660.
- [19] E. Comini, A. Cristalli, G. Faglia, G. Sberveglieri, "Light enhanced gas sensing properties of indium oxide and tin dioxide sensors," *Sensors and Actuators B: Chemical*, vol. 65, 2000, pp. 260–263.
- [20] Chen H., Liu Y., Xie C., Wu J., Zeng D., et al., "A comparative study on UV light activated porous TiO₂ and ZnO film sensors for gas sensing at room temperature," *Ceramics International*, 38, 2012, pp. 503–509.
- [21] S. Mishra, C. Ghanshyam, N. Ram, R. P. Bajpai, R. K. Bedi, "Detection mechanism of metal oxide gas sensor under UV radiation," *Sensors and Actuators B: Chemical*, vol. 97, 2004, pp. 387–390.
- [22] Z. Topalian, J. Smulko, G. A. Niklasson, C. G. Granqvist, "Resistance noise in TiO₂-based thin film gas sensors under ultraviolet irradiation," *Journal of Physics: Conference Series*, vol. 76, 2007, 012056/1–012056/5.
- [23] P. Kalinowski, L. Woźniak, A. Strzelczyk, P. Jasinski, G. Jasinski, "Efficiency of linear and non-linear classifiers for gas identification from electrocatalytic gas sensor," *Metrology and Measurement Systems*, vol. 20, 2013, pp. 501–512.
- [24] C. Distanto, N. Ancona, P. Siciliano, "Support vector machines for olfactory signals recognition," *Sensors and Actuators B: Chemical*, vol. 88, 2003, pp. 30–39.
- [25] R. F. Machado, D. Laskowski, O. Deffenderfer, T. Burch, S. Zheng, et al., "Detection of lung cancer by sensor array analyses of exhaled breath," *American Journal of Respiratory and Critical Care Medicine*, vol. 171, 2005, pp. 1286–1291.
- [26] F. N. Hooge, T. G. M. Kleinpenning, L. K. J. Vandamme, "Experimental studies on $1/f$ noise," *Reports on Progress in Physics*, vol. 44, 1981, pp. 479–532.
- [27] J. Smulko, C. G. Granqvist, L. B. Kish, "On the statistical analysis of noise in chemical sensors and its application for sensing," *Fluctuation and Noise Letters*, vol. 1, 2001, pp. L147–L153.
- [28] G. Schmera G., L. Kish, J. Smulko, "Method of pattern generation for gas recognition," Patent pending, USA, Navy Case, 2010, 96130.
- [29] J. M. Smulko, J. Ederth, L. B. Kish, P. Heszler, C. G. Granqvist, "Higher-order spectra in nanoparticle gas sensors," *Fluctuation and Noise Letters*, vol. 4, 2004, L597-L603.
- [30] S. Vallejos, P. Umek, T. Stoycheva, F. Annanouch, E. Llobet, X. Correig, P. De Marco, C. Bittencourt, C. Blackman, "Single-step deposition of Au- and Pt-nanoparticle-functionalized tungsten oxide nanoneedles synthesized via aerosol-assisted CVD, and used for fabrication of selective gas microsensor arrays", *Advanced Functional Materials*, vol. 23, 2013, pp. 1313–1322.
- [31] P. Geladi, K. Esbensen, "The start and early history of chemometrics: Selected interviews. Part 1," *Journal of Chemometrics*, vol. 4, 2005, pp. 337–354.
- [32] H. C. Chang, L. B. Kish, M. D. King, C. Kwan, "Identification of bacteria by patterns generated from odor spectra," 2009, arXiv preprint arXiv:0902.1368.
- [33] A. P. Turner, N. Magan, "Electronic noses and disease diagnostics," *Nature Reviews Microbiology*, vol. 2, 2004, pp. 161–166.
- [34] P. Kalinowski, L. Woźniak, A. Strzelczyk, P. Jasinski, G. Jasinski, "Efficiency of linear and non-linear classifiers for gas identification from electrocatalytic gas sensor," *Metrology and Measurement Systems*, vol. 20, 2013, pp. 501–512.
- [35] A. Lay-Ekuakille, P. Vergallo, R. Morello, C. De Capua, "Indoor air pollution system based on LED technology," *Measurement*, vol. 47, 2014, pp.749–755,
- [36] C. Kwan, G. Schmera, J. Smulko, L. B. Kish, P. Heszler, C. G. Granqvist, "Advanced agent identification with fluctuation-enhanced sensing," *IEEE Sensors Journal*, vol. 8, 2008, pp. 706–713.