

Eastern Illinois University
The Keep

Masters Theses

Student Theses & Publications

1981

Three-Dimensional Home Range of the Eastern Fox Squirrel, *Sciurus niger*

Joi L. Augustin

Eastern Illinois University

This research is a product of the graduate program in [Zoology](#) at Eastern Illinois University. [Find out more](#) about the program.

Recommended Citation

Augustin, Joi L., "Three-Dimensional Home Range of the Eastern Fox Squirrel, *Sciurus niger*" (1981). *Masters Theses*. 3020.
<https://thekeep.eiu.edu/theses/3020>

This is brought to you for free and open access by the Student Theses & Publications at The Keep. It has been accepted for inclusion in Masters Theses by an authorized administrator of The Keep. For more information, please contact tabruns@eiu.edu.

THESIS REPRODUCTION CERTIFICATE

TO: Graduate Degree Candidates who have written formal theses.

SUBJECT: Permission to reproduce theses.

The University Library is receiving a number of requests from other institutions asking permission to reproduce dissertations for inclusion in their library holdings. Although no copyright laws are involved, we feel that professional courtesy demands that permission be obtained from the author before we allow theses to be copied.

Please sign one of the following statements:

Booth Library of Eastern Illinois University has my permission to lend my thesis to a reputable college or university for the purpose of copying it for inclusion in that institution's library or research holdings.

12/4/81
Date

Author

I respectfully request Booth Library of Eastern Illinois University not allow my thesis be reproduced because _____

Date

Author

THREE-DIMENSIONAL HOME RANGE OF THE

EASTERN FOX SQUIRREL, SCIURUS NIGER
(TITLE)

BY

Joi L. Augustin

THESIS

SUBMITTED IN PARTIAL FULFILLMENT OF THE REQUIREMENTS
FOR THE DEGREE OF

Master of Science

IN THE GRADUATE SCHOOL, EASTERN ILLINOIS UNIVERSITY
CHARLESTON, ILLINOIS

1981
YEAR

I HEREBY RECOMMEND THIS THESIS BE ACCEPTED AS FULFILLING
THIS PART OF THE GRADUATE DEGREE CITED ABOVE

4 Dec 81
DATE

ADVISER

4 Dec 1981
DATE

COMMITTEE MEMBER

4 Dec. 1981
DATE

COMMITTEE MEMBER

4 Dec. 81
DATE

DEPARTMENT CHAIRPERSON

Three-dimensional home range of the
eastern fox squirrel, Sciurus niger

Joi L. Augustin

Abstract: Standard procedures for presenting home range data for species such as the fox squirrel on a single plane do not adequately represent the space they occupy. Comparisons of techniques for presenting the home range of this species on a three-dimensional basis were made using data obtained by direct observations of color marked squirrels. Three-dimensional ellipsoid models of their range varied from $9,154 \text{ m}^3$ to $63,811 \text{ m}^3$ and were assumed to be more accurate when observation points approached 50 in number. Rectangular parallelepipeds for the same data ranged from $9,784 \text{ m}^3$ to $56,836 \text{ m}^3$ and resulted in narrow, linear home ranges. Space within these three-dimensional models was not occupied uniformly since squirrel movements were recorded either at ground level or in the canopy. The most realistic representation of home range, therefore, was as two independent ellipses representing these two planes.

Home range studies have been carried out on a wide variety of vertebrate species. Almost without exception, ranges have been analyzed on a single plane using various techniques (Hayne 1949, Stickel 1954, and Sanderson 1966). Some species, as Milstead (1972) pointed out, are not

confined to a single plane and their home ranges should be analyzed three-dimensionally. The fox squirrel, Sciurus niger, is such a species; it utilizes three-dimensional space even though past studies have reported fox squirrel home range as two-dimensional ellipses (Allen 1943, Adams 1976, and Dyer 1977). A model for a three-dimensional home range was constructed by Koepl et al. (1977) for an individual gray squirrel. Their model presented the home range as an ellipsoid and considered its volume, orientation in space, and confidence level. The purpose of this study was to evaluate the Koepl et al. (1977) technique and compare it with other procedures for three-dimensional home range analysis.

METHODS

This study was conducted over a period of seven months (October 1980 through April 1981) on a portion of a 4 ha woodlot in Coles County, Illinois. The area is an upland forest with dominant trees of walnut, maple, oak, and hickory. Cultivated fields and pastures border the woods except to the east and west where the woods continue along an intermittent stream. This 4 ha woodlot was marked off in 100 foot (30.5 m) quadrats by Dyer (1977).

Dominant trees in a 1.5 ha portion of the woodlot were mapped to provide landmarks for recording squirrel observations. Height of the top and bottom of the canopy was measured with an Abney level. The average height of dens occurred at mid-canopy level, 16.8 m above ground; the majority of observations were made near den sites. Because of the difficulty of recording varying heights of movements within the canopy, 16.8 m was utilized as the height for all arboreal observations.

Twenty sliding door squirrel traps baited with ear corn were set continuously throughout the study. Traps were placed randomly near major landmarks and spaced roughly 20 m apart; 1 or 2 hours before sunset the traps were checked. Squirrels were transferred to a wire cone and marked in differential patterns with a fur dye (Nyanzol A). Permanent numbered tags were placed in ears; age and sex were recorded.

Observations of marked squirrels were made approximately every other day primarily from just before sunrise to early afternoon, this being a period of intense activity for the fox squirrel (Hicks, 1949). Locations of squirrels were recorded at five minute intervals by direct observation from along southern edge of study area. Capture points, observation points, and trees used were recorded on a map; points were differentiated as either a terrestrial or an arboreal (16.8 m) location. These location points were plotted in three planes: 1) with x and y axes representing east-west and north-south respectively, 2) with x and z axes, the z representing height, and 3) with y and z axes. Centers of activity (Hayne, 1949) were calculated with three coordinates for each individual's home range.

Location points were plotted on the x-y plane to establish a two-dimensional map of home ranges. A straight line, the major axis of an ellipse as described by Hayne (1949), was drawn through the center of activity and parallel to a line through the two most distant observation points (Stumpf and Mohr, 1962). The minor axis whose length was determined by the distance of the furthest point from the major axis was drawn perpendicular to and divided the major axis into two equal parts. Two-dimensional home range area was calculated as an ellipse in the x-y plane using the equation: $A_e = \pi ab$. In this equation, "a" represents half

the major axis and "b" half the minor axis. The percentage of points included within the ellipse was considered to be the confidence level of the ellipse.

An ellipse was also drawn on both the x-z and y-z planes for three-dimensional ranges. These ellipses differed in that the major axes were drawn parallel to the x axis, thus both ellipses paralleled the ground. Ellipses of the three planes were superimposed to form a three-dimensional ellipsoid for each individual home range. The volume of the ellipsoid was calculated by the formula: $V_e = 4/3 \pi abc$. The lengths of the semi-axes of the ellipsoid are represented by a, b, and c. Confidence of ellipsoids was determined as for two-dimensional ranges.

A second method for calculating three-dimensional home ranges involved using a rectangular parallelepiped, a three-dimensional figure whose six bases are parallelograms. Rectangular parallelepipeds were drawn to compare with each ellipsoid such that the length represents the greatest distance between points, the height represents 16.8 m, and the width represents the distance required to include the same percentage of points as its respective ellipsoid. Volume was determined by the product of the length, height, and width.

Arboreal and terrestrial location points were each differentiated into an elliptical, two-dimensional home range, in a third method of presenting three-dimensional home range data. Trees used for travel between canopy and ground levels were shown as pathways between ranges. Home range size was presented as a ratio: arboreal area/terrestrial area. The area of each ellipse was calculated following the method for ellipses in the x-y plane; the confidence level was considered as the percentage of points included in both ellipses.

RESULTS

Sixteen fox squirrels were trapped, color marked, ear tagged, and released on the study area. Ten of these were subsequently observed or recaptured; ten or more location points were available for seven animals. Two-dimensional home range sizes, x-y plane, ranged from 817 to 5,697 m² (Table 1). The two-dimensional range of one squirrel, an adult male with 49 location points, is shown graphically in Figure 1c. Three-dimensional ranges were based on an ellipse of the x-y as well as the x-z (Fig. 1a) and y-z (Fig. 1b) planes. The resulting ellipsoid (Fig. 1d) for the male with 49 location points surrounded 80% of the observation points and had a volume of 55,608 m³ (Table 1). A rectangular parallelepiped (Fig. 2) also containing 80% of location points for the same adult male had a volume of 56,836 m³. Comparatively when the home range was calculated as arboreal ellipses over terrestrial ellipses (Fig. 3), the size of a home range containing 90% of location points for this adult male was 5,306 m²/4,136 m²; the size of home range for an adult female with 20 location points was 394 m²/2,100 m² and contained 85% of location points. Volumes of the ellipsoids, rectangular parallelepipeds, and arboreal/terrestrial ratios of all seven squirrels and composite are shown in Table 1.

DISCUSSION

Past studies have considered fox squirrel home ranges as two-dimensional polygons, circles, and ellipses (Allen 1943, Adams 1976, and Dyer 1977). Two-dimensional home range, while adequate for species utilizing a single plane is inadequate for species such as the fox squirrel. This animal spends a great deal of time arboreally foraging, escaping from enemies, mating, rearing young, or basking in the sun. A two-dimensional

Table 1: Comparisons of fox squirrel home range calculated as both two-dimensional areas and three-dimensional volumes.

Squirrel	Observations	Two-dimensional Ellipse		Three-dimensional					
		Size	Confidence	Ellipsoid		Rectangular Parallelepiped		Arboreal/Terrestrial	
				Size	Confidence	Size	Confidence	Size	Confidence
Adult male	10	1,266 m ²	60%	14,180 m ³	40%	9,784 m ³	40%	24 m ² /914 m ²	50%
Adult female	13	817 m ²	62%	9,154 m ³	31%	9,869 m ³	31%	511 m ² /921 m ²	69%
Adult male	16	5,022 m ²	87%	56,251 m ³	63%	53,897 m ³	63%	84 m ² /4,492 m ²	81%
Adult male	20	1,409 m ²	70%	15,783 m ³	40%	19,676 m ³	40%	1,066 m ² /1,379 m ²	75%
Adult female	20	3,099 m ²	80%	34,703 m ³	45%	23,427 m ³	45%	394 m ² /2,100 m ²	85%
Adult male	49	4,965 m ²	94%	55,608 m ³	80%	56,836 m ³	80%	5,306 m ² /4,136 m ²	90%
Juvenile female	53	4,058 m ²	93%	45,447 m ³	72%	36,933 m ³	72%	3,066 m ² /3,105 m ²	87%
Composite	196	5,697 m ²	98%	63,811 m ³	81%	52,491 m ³	81%	5,263 m ² /5,170 m ²	96%

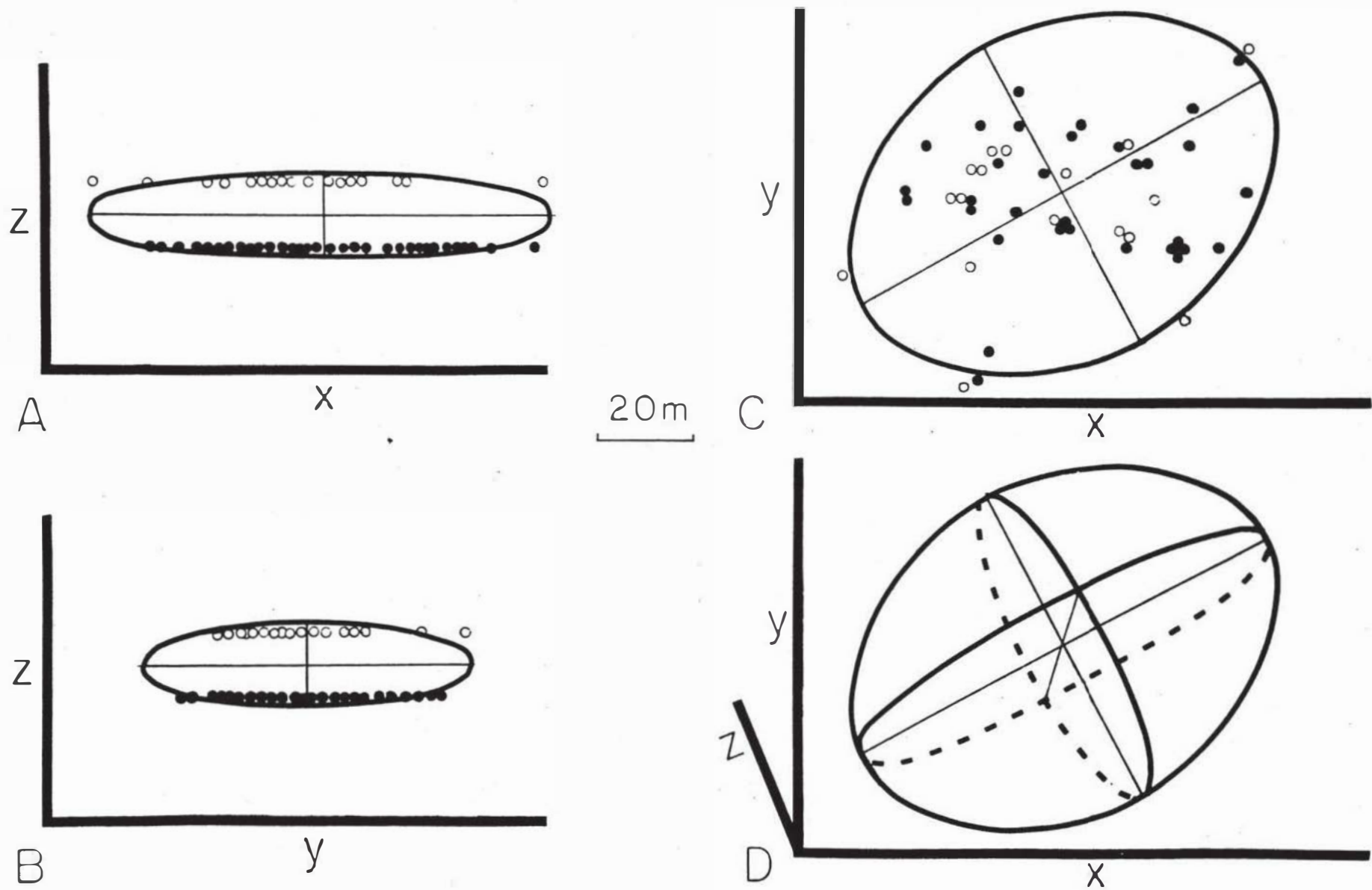

Figure 1: Elliptical home range of an adult male fox squirrel with 49 observations: a) x-z plane, b) y-z plane, c) x-y plane, and d) three-dimensional ellipsoid formed by superimposing a, b, and c. o = arboreal observation, • = terrestrial observation.

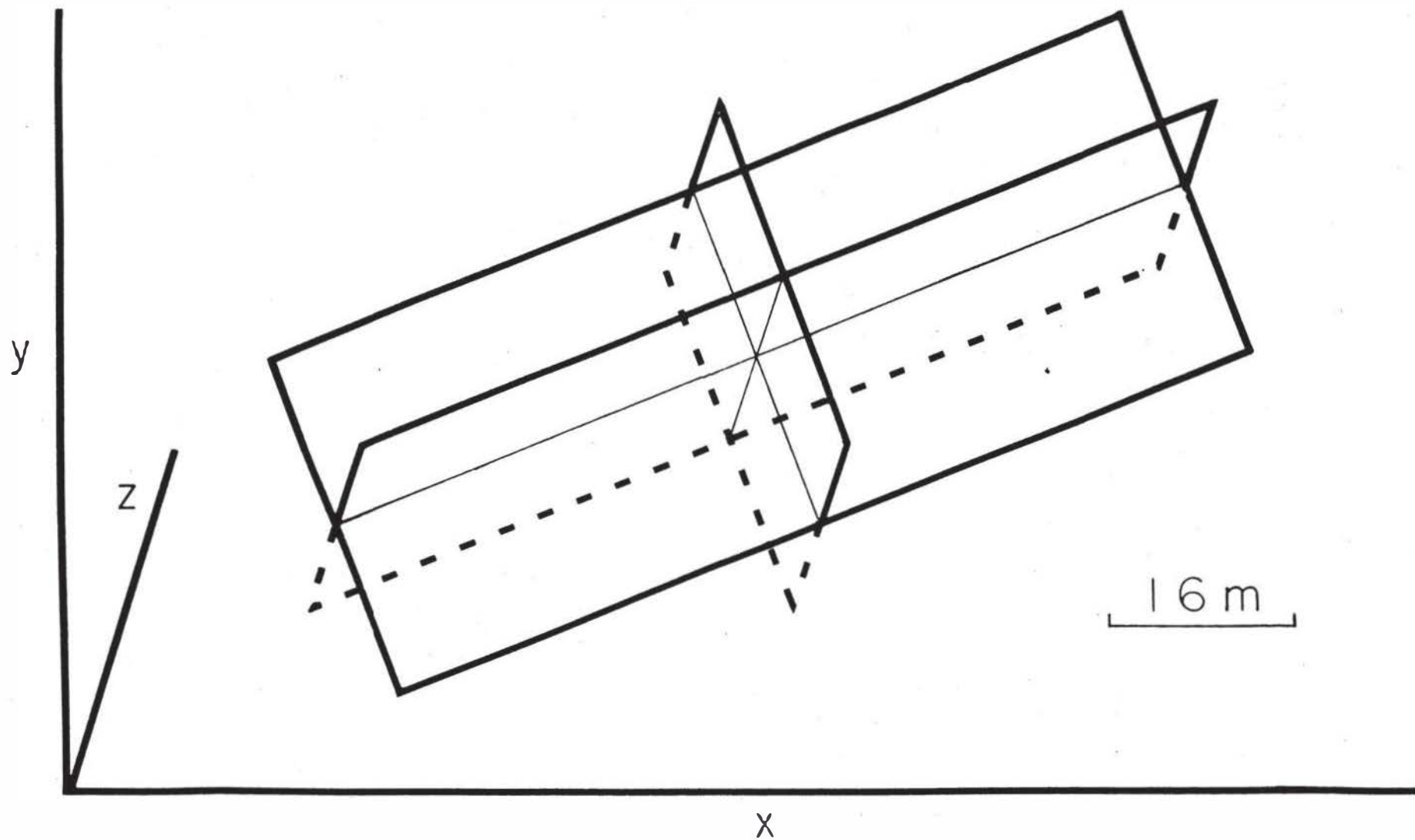

Figure 2: Three planes of a rectangular parallelepiped representing the home range of the same adult male fox squirrel in Figure 1.

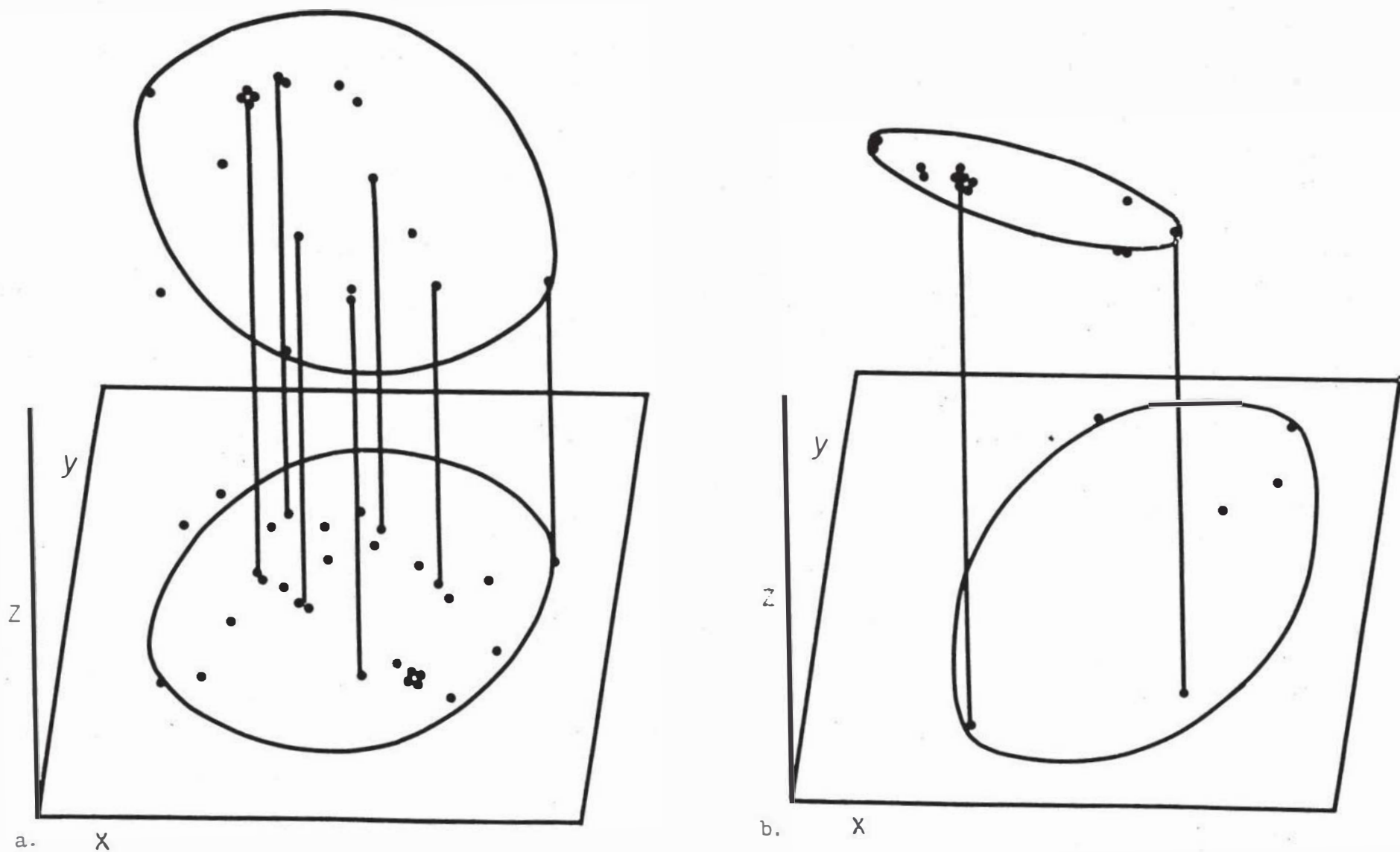

Figure 3: Elliptical arboreal and terrestrial ranges, one atop the other, with vertical lines representing pathways between ranges. a) adult male home range with 49 observations; x, y, and z axes representing 114 m, 91 m, and 16,8 m respectively, b) adult female home range with 20 observations; x, y, and z axes representing 80 m, 54 m, and 16,8 m respectively.

range ignores the arboreal aspect of their range which can only be adequately represented by some approach of three-dimensional representation and analysis.

An elliptical two-dimensional home range has often been advocated, (Sanderson 1966, Jenrich and Turner 1969, Adams 1976, and Koepl et al. 1975), because the procedure illustrates the linearity characteristic of many home ranges and is considered to present a more accurate estimate of range size. A three-dimensional home range based on ellipses may have the same advantages. Koepl et al. (1977) used an ellipsoid to represent locational data from an individual gray squirrel; however, they failed to calculate the actual volume of the ellipsoid.

Koepl et al. (1977) stated the minimum sample size for three-dimensional ellipsoids should be greater than 20. I calculated three-dimensional ellipsoids with sample sizes ranging from 10 to 53 and found confidence levels to increase when sample size approached 50 (Table 1). The Koepl et al. (1977) ellipsoid intersected the ground at a confidence level of 95%. While my confidence levels are lower, all parts of the ellipsoid are above ground and could be occupied by squirrels. The major limitation of this procedure for use with my data was that location points were not evenly distributed throughout the space of the three-dimensional ellipsoid but rather were confined either to the ground or to the canopy. Perhaps if locational points were scattered throughout the three-dimensional space, confidence levels would increase.

The rectangular parallelepiped presented three-dimensional home range similar to the ellipsoid and has the same limitation. This procedure resulted in smaller home ranges than did ellipsoids at the same confidence

levels (Table 1). While the length and height equal that of a comparable ellipsoid (Fig. 1d), the width of the rectangular parallelepiped was less; therefore the rectangular parallelepiped presented linear, compact home range (Fig. 2).

The use of independent but related two-dimensional ranges (Fig. 3) overcomes the limitations of rectangular parallelepiped and ellipsoid approaches. In this way variations in use of either ground or canopy based on changes in seasonal foraging, breeding seasons, age, or sex could be represented more accurately. Furthermore, vertical paths from arboreal to terrestrial parts of the range can be illustrated. The adult male shows a larger arboreal range than terrestrial (Fig. 3a), perhaps reflecting increased arboreal activity during the breeding season. While the terrestrial range is considerably larger for the female (Fig. 3b), more time appears to be spent arboreally by the larger number of observation points within that plane. This female was known to have a litter of three young and rarely strayed from the nest except to forage.

Data for this study were obtained by direct observation. This method, while an improvement over live trapping, still has its limitations. Sanderson (1966) stated that only a few can be studied at a time, it is very time consuming, and the observer must be close to an animal which may influence movements. Another disadvantage is the difficulty of following movements through heavy foliage. Perhaps the best way of obtaining three-dimensional locational data is by radiotelemetry. Movements throughout canopy could be easily recorded and a more accurate representation of range size could be attained. To interpret the data, use of computer analysis in plotting points and calculating volumes would be helpful in presenting the three-dimensional home range.

ACKNOWLEDGEMENTS

I would like to thank Richard Andrews for his advice and support throughout the study. E. O. Moll, M. Goodrich, and L. Durham reviewed the manuscript and offered suggestions. Lyla Andrews assisted in collection of data. A very special thanks to Steve Lacine, Cathy Kuhl, and Donita Doyle for their encouragement and assistance in the field.

LITERATURE CITED

- Adams, C. E. 1976. Measurement and characteristics of fox squirrel, Sciurus niger rufiventer, home ranges. Amer. Mid. Nat. 95:211-215.
- Allen, D. L. 1943. Michigan fox squirrel management. Mich. Dept. Cons. Game Div. Pub. 100. 404 pp.
- Dyer, S. L. 1977. Home range and movements of fox squirrels (Sciurus niger) in east central Illinois. M.S. Thesis. Eastern Ill. Univ., Charleston. 30 pp.
- Hayne, D. W. 1949. Calculation of size of home range. J. Mam. 30:1-17.
- Hicks, E. A. 1949. Ecological factors affecting the activity of the activity of the western fox squirrel, Sciurus niger rufiventer (Geoffroy). Ecol. Mono. 19:289-301.
- Jenrich, R. I. and F. B. Turner. 1969. Measurement of non-circular home range. J. Theoret. Biol. 22:227-237.
- Koeppl, J. W., Slade, N. A., Harris, K. S., and R. S. Hoffman. 1977. A three-dimensional home range model. J. Mam. 58:213-220.
- Koeppl, J. W., Slade, N. A., and R. S. Hoffman. 1975. A bivariate home range model with possible application to ethological data. J. Mam. 56:81-90.
- Milstead, W. W. 1972. More on lizard home ranges. Herpetol. Rev. 4:83-84.
- Sanderson, G. C. 1966. The study of mammal movements--a review. J. Wildl. Mgt. 30:215-235.
- Stickel, L. F. 1954. A comparison of certain methods of measuring ranges of small mammals. J. Mam. 35:1-15.
- Stumpf, W. A. and C. O. Mohr. 1962. Linearity of home ranges of California mice and other animals. J. Wildl. Mgt. 26:149-154.

LITERATURE REVIEW

Home ranges and methods of measuring them have received much attention during the past few decades. Most home range studies have been two-dimensional even though some species have ranges that should be measured in three dimensions. This review describes and discusses the various techniques for measuring home range and summarizes home range studies of fox squirrels, a species which has a three-dimensional home range.

Home range was defined by Burt (1943) as the area an individual travels in his daily activity whether foraging, mating, or caring for young. Burt further states that the home range of an individual may vary in size depending on sex, age, or season of the year; the boundaries of an individual's home range may also vary during it's lifetime. And finally, Burt points out that home ranges are rarely in convenient geometric designs, however, most probably have an ameboid shape.

When studying home range, data may be collected by live trapping, by direct observation, by radiotracking, or by a combination of these. Davis (1953) points out the difficulty of using recapture data for species which can rarely be recaptured or that travel lengthy distances. Direct observation or radiotracking may be the only suitable method for such species. Advantages of direct observation over trapping are the rare handling of individuals, movements are not hampered by recapture, and if correctly identified, there is little chance of mistaking where an animal is and what it is doing (Sanderson, 1966). Disadvantages stated by Sanderson are that only a few can be

studied at a time, it is very time consuming, and the observer must be close to an animal which may influence movements.

After the collection of data on movements, various methods can be used to estimate a home range size. Hayne (1949) discussed various approaches for estimating the size of home range from data obtained by live trapping and categorized these methods in three ways: 1) those which only use area enclosed by points of capture, 2) those that add a boundary zone to that area, and 3) those which consider the greatest distance between capture points to be the major axis of the home range.

The first category forms a minimum polygon by enclosing the outside points of capture. The area of this polygon is then calculated as the home range. Advantages of this method are that the enclosed area is without a doubt an area used by the animal. The minimum polygon approach presents home range conservatively and isn't likely to over-estimate its size. Arguments against this method are that the home range is not likely to coincide with the distribution of traps and that if an animal is only taken in two traps no home range can be calculated.

The second category or boundary strip method recognizes that the animal is probably not confined to the minimum polygon although the area used beyond the minimum polygon is not known. The minimum polygon is extended a distance beyond the outside points of capture, usually equal to one-half the distance to the next trap. Two variations of this method were discussed by Stickel (1954). The exclusive boundary strip method connects points of capture so that

the smallest possible area is enclosed; the inclusive boundary strip method connects the points of capture so that the largest possible area is enclosed.

The third category of methods estimated home range on the basis of the greatest distance between points of capture or observation. This distance or range length has been utilized in several ways. Hayne (1949) suggested that the greatest distance between capture points could represent the diameter of a circular range or the major axis of an elliptical range. Lay (1942), Stuewer (1943), and Stickel (1946), for example, used the greatest distance between captures to calculate circular ranges. Stickel (1954) used the observed range length as a comparative linear expression of range size. She adjusted the range length by adding one-half the distance to the next trap to each end of the line representing length.

Hayne (1949) described an additional method of expressing trapping results by determining the geographic center of all points of capture. In two-dimensional Cartesian space, the points of capture have vertical and horizontal values which are both averaged to give the coordinates of the point on the map which is the center of activity. The distance from the center of activity to the farthest point of capture was termed the recapture radius of a circular home range. Hayne cautioned that this point, the center of activity, had no biological significance and should not be identified with the home site of the animal.

A combination of centers of activity and the greatest distances between capture points was used by Stumpf and Mohr (1962). The center

of activity was calculated and a line was drawn through this center and parallel to a line through the most distant capture points. This line, the linear axis, and the centers of activity were then superimposed to produce a composite home range for several individuals. Mohr used the procedure to illustrate the linear characteristics of the home range of a number of species.

Mohr (1965) compared the composite method to the minimum polygon home range method with data obtained by direct observation of red squirrels. The sizes and shapes of the polygons within which 50, 67, and 90 percent of the composite point observations closest to the linear axis were used in determining areas of the home ranges. These results were compared with those obtained from the minimum polygon method in which areas are calculated for each individual. The composite method of determining home range results in larger averages than does the widely used minimum home range method when the composite is based on 90 percent of observed points in the polygon; however, when based on 67 percent, the composite average is smaller, more compact than the minimum home range method (Mohr, 1965). The shapes of adult red squirrel home ranges were relatively narrow. Mohr concluded that this linearity relates positively with the condition of the habitat.

Jenrich and Turner (1969) pointed out that the minimum polygon and the recapture radius methods calculate home ranges that are incomparable. They proposed a new method free from sample size bias and the assumption of circular shape of home ranges. Circular home range calculations based on recapture radii indices tend to

underestimate the area encompassing the range. Their new index is similar to recapture radius but is designed to measure non-circular home ranges as well and was based on determining a covariance matrix of the capture points.

A similar method for calculating a non-circular two-dimensional home range was presented by Koepl et al. (1975) which was later extended into a three-dimensional home range model (Koepl et al., 1977). They used unpublished data (collected by Harris) to present a mathematical model for analyzing three-dimensional location data obtained from observing an adult gray squirrel. The work of Koepl et al. (1977) is the only attempt to date at presenting three-dimensional home range. They recognize that species such as tree squirrels utilize an arboreal range as well as a terrestrial range and therefore movements are in three spatial dimensions.

Some of the first work with fox squirrels gave insight on movements. In a study on the fox squirrel in Ohio by Baumgartner (1943), he suggested, "the movement of an individual in its home range is such that it covers most of the area on an average of once every three days." Baumgartner found most activity to occur within two or three acres and he suggested a relationship exists between the sizes of the home range and the woodlot where they occur. Brown and Yeager (1945) studied the fox squirrel as an important game animal in Illinois; they found an average population density of one squirrel per acre of good Illinois habitat. A seasonal range of 10 acres and a yearly home range of 40 acres was found by Allen (1943) for Michigan fox squirrels.

Further home range studies have been carried out on fox squirrel populations by using live trapping and radiotelemetry. Adams (1976) found ellipses rather than polygons or circles to best represent the home range of Nebraska fox squirrels. He found a mean home range of 7.56 ha for males, 3.55 ha for females, 9.27 ha for adults, 15.20 ha for yearlings, and 3.07 ha for juveniles. Lyer (1977) calculated minimum home range, observed range length, composite home range, and centers of activity for fox squirrels by live trapping in east central Illinois. Minimum home range for males, females, adults, and juveniles was 0.67, 0.60, 0.78, and 0.60 ha respectively. St. Peter (1977) found similar results on the same study area.

LITERATURE REVIEW CITATIONS

- Adams, C. E. 1976. Measurement and characteristics of fox squirrel, Sciurus niger rufiventer, home ranges. Amer. Mid. Nat. 95:211-215.
- Allen, D. L. 1943. Michigan fox squirrel management. Mich. Dept. Cons. Game Div. Pub. 100. 404 pp.
- Baumgartner, L. L. 1943. Fox squirrels in Ohio. J. Wildl. Mgt. 7:193-202.
- Brown, L. G. and L. E. Yeager. 1945. Fox squirrels and gray squirrels in Illinois. Bull. Ill. Nat. Hist. Surv. 23:449-536.
- Burt, W. H. 1943. Territoriality and home range concepts as applied to mammals. J. Mam. 24:346-352.
- Davis, D. E. 1953. Analysis of home range from recapture data. J. Mam. 34:352-358.
- Dyer, S. J. 1977. Home range and movements of fox squirrels (Sciurus niger) in east central Illinois. M.S. Thesis. Eastern Ill. Univ., Charleston. 30 pp.
- Hayne, D. W. 1949. Calculation of size of home range. J. Mam. 30:1-17.
- Jenrich, R. I. and F. B. Turner. 1969. Measurement of non-circular home range. J. Theoret. Biol. 22:227-237.
- Koepl, J. W., Slade, N. A., Harris, K. S., and R. S. Hoffman. 1977. A three-dimensional home range model. J. Mam. 58:213-220.
- Koepl, J. W., Slade, N. A., and R. S. Hoffman. 1975. A bivariate home range model with possible application to ethological data. J. Mam. 56:81-90.
- Lay, D. W. 1942. Ecology of the opossum in eastern Texas. J. Mam. 23:147-159.
- Mohr, C. O. 1965. Home area and comparative biomass of the North American red squirrel. Can. Field Nat. 79:162-171.
- St. Peter, T. R. 1977. Ecology of a mixed gray and fox squirrel population. M.S. Thesis. Eastern Ill. Univ., Charleston. 36 pp.
- Sanderson, C. C. 1966. The study of mammal movements--a review. J. Wildl. Mgt. 30:215-235.
- Stickel, L. F. 1946. The source of animals moving into a depopulated area. J. Mam. 27:301-307.
- Stickel, L. F. 1954. A comparison of certain methods of measuring ranges of small mammals. J. Mam. 35:1-15.

Stuewer, F. W. 1943. Raccoons: their habits and management in Michigan. Ecol. Mono. 13:203-258.

Stumpf, W. A. and C. O. Mohr. 1962. Linearity of home ranges of California mice and other animals. J. Wildl. Mgt. 26:149-154.