



UNIVERSIDADE DA BEIRA INTERIOR
Engenharia

Business Model for Air Transportation in Specific Market Segments Airships for Logistics Case Study

Inês Ramos da Cruz

Dissertação para obtenção do Grau de Mestre em
Engenharia Aeronáutica
(Ciclo de estudos integrado)

Orientador: Prof. Doutor Jorge Miguel dos Reis Silva

Covilhã, Setembro de 2017

“A journey of a thousand miles begins with a single step”
Famous Chinese proverb ascribed to Laozi

Acknowledgements

First of all, I would like to express my deepest appreciation to Professor Jorge Miguel dos Reis Silva for having accepted to embark on my last academic journey. Without his guidance and persistent help, this dissertation would not have been possible.

I have a great sense of gratitude towards Engenheira Maria Emília Baltazar, who aided me by providing all the necessary tools and advice for me to build a strong foundation for this thesis.

A profuse thank you to all the proudly called “NITeiros” who were always the first to lend a helping hand and share knowledge.

My sincere thankfulness to Doutor Miguel Ribeirinho and Doutor Pedro Carvalho.

It is a pleasure to acknowledge my thanks and gratitude to my friends Maria Cunha, Pedro Batista, Sofia Soares, Rita Marques, Mariana Costa and Beatriz Leal who were able to keep my sanity above average during this “expedition”.

For me it is an honour and proud privilege to thank my parents, Natália and José for being my first mentors and guiders in life, for always helping me to the best of their abilities and providing me with all I need to get this far and fulfil this milestone, I sincerely thank you.

Last but certainly not the least, I would like to give my special thanks to my sister Catarina who was my pillar during this process. Thank you for all the encouragement, never allowing me to give up and for “stepping forward” to read this work.

This journey has come to fruition and I am glad you have all been there with me.

Resumo

Desde os tempos mais primordiais, o Homem teve a necessidade de transportar bens, pessoas ou animais.

Com os avanços e mudanças da tecnologia, também a procura de transporte por parte dos utilizadores sofreu alterações. Neste sentido surgiram novos meios de transporte e os dirigíveis, por exemplo, começaram a ser alvo de um crescente nível de atenção, sobretudo devido ao facto de as entidades aeronáuticas terem uma maior preocupação com a adoção de tecnologias amigas do ambiente.

Neste século, os dirigíveis começaram a ter a sua quota-parte nos mais diversos usos: publicidade, vigilância, monitorização, investigação e turismo. Nesta dissertação foi analisado um outro uso, o transporte de carga, para perceber se este poderia ser uma alternativa prática relativamente ao transporte rodoviário e se assim se poderia contrariar algumas das restrições encontradas no que toca à logística tais como: vias rodoviárias em mau estado de conservação, interdições à circulação de alguns tipos de veículos em certas áreas, e congestionamento de tráfego.

Neste trabalho mostrou-se como a utilização de dirigíveis para o transporte de carga e, consequentemente, o seu papel em termos da logística de distribuição, é exequível. Para tal, foram analisados os elementos essenciais a um modelo e plano de negócios, estudadas as metodologias de otimização em rede de possíveis rotas, e abordado um caso de estudo com base na operação real de uma empresa no mercado nacional. Os resultados confirmaram a viabilidade dos pressupostos iniciais corroborando as vantagens (mas também os desafios) da utilização de dirigíveis na cadeia logística do transporte de carga.

Palavras-chave

Desempenho Operacional; Dirigíveis; Logística; Otimização de Redes; Plano de Negócios.

Resumo alargado

Introdução

Serve a presente secção para explicar e demonstrar resumidamente o trabalho de MSc efetuado.

Primeiramente é descrito o enquadramento da dissertação, consecutivamente são explicados os casos de estudo e finalmente são indicadas as conclusões e quais as perspetivas de trabalhos futuros.

Enquadramento da dissertação

A intensidade do tráfego e congestionamento nas cidades, principalmente em áreas mais centrais, são os principais responsáveis pela redução das deslocações diárias e pelo aumento do seu tempo, aumentando assim também o custo do transporte e pondo em causa a venda a retalho.

A entrega de produtos, especialmente na indústria alimentar, é feita por diferentes operadores nos mesmos dias da semana o que resulta em congestão de bens, devido a múltiplas cargas e descargas a acontecer simultaneamente. Em zonas mais centrais a morfologia urbana dificulta o fluxo de tráfego e as cargas/descargas, além de causar interdição de acesso a veículos a tentarem alcançar alguns estabelecimentos aí localizados. As companhias de transporte vêm-se obrigadas a alterar o seu horário de entregas e a organização das mesmas de modo a mitigar as dificuldades existentes, o que por si só resulta em mais despesas.

Uma das hipóteses que permite preencher a lacuna apresentada são os dirigíveis visto que são o ponto mediano entre velocidade e o consumo de combustível. Apesar de já terem a sua quota-parte de história, são inovadores pela tecnologia que utilizam. Grandes empresas começaram já a investir neste nicho de mercado.

Objetivos

O objetivo deste trabalho é analisar e avaliar a viabilidade técnica e económica do modelo de negócio resultante da utilização de um dirigível para logística. No entanto há um leque de sub-objetivos a serem cumpridos de modo a satisfazer a proposta, como avaliar o tipo de dirigível, avaliar o impacto económico que pode trazer a implementação desta solução, e se, de acordo com a tecnologia atual, será a solução mais adequada para corresponder aos problemas da logística.

Caso de estudo

O caso de estudo na realidade pode ser dividido em três casos diferentes pois aplicamos a mais do que um cenário uma solução-base idêntica para, deste modo, aferir qual a resposta melhor do nosso modelo. Ou seja, partindo de uma solução de transporte real, já existente (utilizando

o modo rodoviário), analisámos três cenários: dois utilizando apenas o dirigível, e um terceiro em que este veículo partilhava a operação logística com o modo rodoviário.

Nos casos de estudo tidos em conta a escolha da empresa teve que ser muito refletida pois a carga teria que ser relativamente homogénea e paletizável. Assim sendo a escolha recaiu numa empresa nacional de comercialização e transporte de café para toda a Península Ibérica.

Os três casos de estudo, que englobam 4 cidades portuguesas - incluindo a sede da empresa, foram os seguintes:

- Caso de estudo 1 - o dirigível é usado cinco dias por semana de modo a igualar o sistema de transporte de carga normalmente entregue pela empresa;
- Caso de estudo 2 - o dirigível faz o transporte de carga não só nos dias uteis, mas 7 dias por semana;
- Caso de estudo 3 - a distribuição de café é feita de um modo que combina o transporte feito por camião (entre a sede da empresa e um depósito numa das cidades) e aquele feito com recurso a dirigíveis (desse depósito para as outras duas cidades).

Aplicando algoritmos de otimização em rede e usando os resultados obtidos para a elaboração de um plano de negócio, o cenário que oferece o decréscimo mais significativo dos custos é o referente ao Caso de estudo 2 (Tabela 1). Senão, vejamos:

- No caso de estudo 1 os parâmetros mensais foram 10.760 km percorridos que correspondem a cerca de 73 horas de voo (a velocidade cruzeiro do dirigível é 148 km/h). Se o custo por hora que o dirigível voa for 180 €, o custo mensal equivale a 13.140 € (este caso não inclui custos de armazenamento). Em transporte rodoviário a empresa dispense, mensalmente, cerca de 13.810 € (incluído despesas de armazenamento). Neste caso, em particular, a distância percorrida é de 6.600 km (o que se traduz em aproximadamente 66 horas). Tendo em conta esta informação, é claro que pela implementação da solução do caso de estudo 1 o tempo dispendido aumentaria 10%, o custo do transporte diminuiria 4%, e a distância percorrida sofreria um aumento de 63%;
- No caso de estudo 2 os parâmetros obtidos foram 9.184 km percorridos em 62 horas e um custo de 11.160 € (este caso também não implica custos de armazenamento). Isto significa que o dirigível voa 10% menos quando comparado ao tempo dispendido pelo transporte rodoviário, e há ainda uma diminuição de 20% nos custos associados à sua utilização; no entanto, há um acréscimo na ordem dos 39% no que diz respeito à distância percorrida;
- No caso de estudo 3, observa-se um total de 5.640 km voados em 38 horas com um custo de 14.490 € (ao contrário dos casos anteriores este implica custos de armazenamento). A implementação desta solução resultaria numa redução quer das horas de voo (42%) que dos quilómetros viajados (15%), mas também implicaria um aumento de 5% em termos de custos.

Tabela 1 - Comparação entre parâmetros relativos à solução atualmente em vigor e os obtidos para cada caso de estudo. Elaboração própria.

	Tempo (h)	Custo (€)	Distância (km)	Tempo Relativo	Custo Relativo	Distância Relativa
Modo Rodoviário	66	13.810	6.600			
Caso de Estudo 1	73	13.140	10.760	↑ 10%	↓ 4%	↑ 63%
Caso de Estudo 2	62	11.160	9.184	↓ 6%	↓ 20%	↑ 39%
Caso de Estudo 3	38	14.490	5.640	↓ 42%	↑ 5%	↓ 15%

Principais conclusões

De acordo com os estudos mais recentes a população global tem um crescimento previsto de 9.1 mil milhões até 2050 e os habitantes de zonas urbanas terão um aumento na ordem dos 50 a 70% do total da população mundial. Isto irá certamente traduzir-se num crescimento exponencial da procura em transporte e assim acentuar todos os problemas relacionados com logística.

De acordo com a análise efetuada, foram obtidos resultados promissores de modo a demonstrar a viabilidade do estudo quando financiado por acionistas e desde que o preço por hora de voo não exceda 180 €, estas condições garantirá um lucro de 52.67% sobre as receitas.

Perspetivas de trabalhos futuros

No entanto há ainda algumas tarefas a serem cumpridas de modo a tornar esta proposta o mais completa e precisa possível:

- Estudo de mercado e procura;
- Análise da atratividade;
- Análise de sensibilidade operacional e económicas;
- Procurar e aplicar outras fontes de rendimento (por exemplo transmissão de eventos).

Abstract

Since the beginning of times, humanity has needed transportation of goods, people or animals.

As technology advanced and changed, the user's demand was modified. Hence new means of transportation started arising and airships, for instance, have been getting an increasing amount of attention, mostly due to the fact that aeronautical entities have been concerned with adopting environmentally friendly technologies.

In this century, airships started to have their fair share of distinct uses: advertisement, surveillance, monitoring, investigation and tourism. In this dissertation another use was analysed, this was logistics freight transportation to inquire if it would be a practical alternative to road transportation and if it could counter some of the nowadays' restraints found in logistics such as poor street conditions, interdiction to the circulation of some vehicles in certain areas, and traffic congestion.

In this thesis, it was shown how using airships for freight and consequently its role in terms of logistics' distribution is feasible. To do so, the vital elements of a business plan and model were analysed, the network route optimisation methodologies were studied and an approach to a case study based on a real company's operation in the national market was made. The results confirmed the viability of the initial assumptions corroborating the advantages (along with the challenges) of using airships in the logistics chain of freight transportation.

Keywords

Airships; Business Plan; Logistics; Network Optimization; Operational Performance.

Table of Contents

Acknowledgements	v
Resumo	vii
Resumo alargado	ix
Abstract.....	xiii
Table of Contents.....	xv
List of Tables	xix
List of Acronyms	xxi
Chapter 1	1
Introduction	1
1.1 Motivation.....	3
1.2 Object and Objectives.....	5
1.3 Dissertation Structure and Methodology.....	5
Chapter 2	7
State of the Art - Literature Review	7
2.1 Introduction	9
2.2 Business Models	9
2.2.1 Osterwalder and Pigneur’s Business Model Canvas	10
2.2.2 Business Plan	12
2.3 Logistics	12
2.3.1 Introduction	12
2.3.2 Market Segments	13
2.3.3 Market Regulation	14
2.3.4 Agents and Stakeholders	15
2.4 Air Cargo Transportation	17
2.4.1 Introduction	17
2.4.2 Special Cargo.....	17
2.4.3 Goods.....	18
2.5 Airships	19
2.5.1 History Note	19
2.5.2 Types	22
2.5.3 Application Examples	23
2.6 Conclusion	26
Chapter 3	27
Operational Performance and Cost Structure Optimisation	27
3.1 Introduction	29
3.2 Travelling Salesman Problem.....	29
3.3 Clarke and Wright Algorithm	32

3.4	Conclusion	35
Chapter 4	37
Case Study	37
4.1	Introduction	39
4.2	Airship Characteristics.....	39
4.3	Business Model	41
4.3.1	Cargo	41
4.3.2	Business Model Canvas	41
4.3.2.1.	Customer Segments	41
4.3.2.2.	Key Resources.....	41
4.3.2.3.	Key Partners.....	42
4.4	Solution Implementation	42
4.4.1	Introduction	42
4.4.2	Case Study 1.....	44
4.4.3	Case Study 2.....	47
4.4.4	Case Study 3.....	48
4.4.5	Conclusion	51
4.5	Business Plan	52
4.5.1	Cost Structures	54
4.5.2	Revenue Streams	55
4.6	Conclusion	55
Chapter 5	57
Result Analysis	57
5.1	Introduction	59
5.2	Business Plan	59
5.2.1	Costs	59
5.2.2	Revenues.....	60
5.2.3	Profits	61
5.3	Comparison Between Actual Transportation and Airship Transportation.....	61
5.4	Conclusion	63
Chapter 6	65
Conclusions	65
6.1	Dissertation Summary.....	67
6.2	Concluding Remarks.....	68
6.3	Prospects for Future Work	68
References	71
Annex 1	75
Publications' Abstracts	75

List of Figures

Figure 1. 1 - Usage of petroleum in the different fields in the USA.	3
Figure 1. 2 - Boeing world air cargo forecast 2016-2017.	4
Figure 1. 3 - Fuel consumption and speed according to each type of transportation.	4
Figure 1. 4 - Scheme of this thesis methodology.....	6
Figure 2. 1 - Business Model Canvas.	11
Figure 2. 2 - Top challenges faced by shippers.	13
Figure 2. 3 - Agents and stakeholders in freight logistics.	15
Figure 2. 4 - Value, shelf life, and dominant transport modes in intercontinental movements of food products and ornamentals.	19
Figure 2. 5 - History of airships according to their type from 1850 until 1960 divided by structure types: rigid (a), semi-rigid (b) and non-rigid (c).	21
Figure 2. 6 - Companies that manufacture airships according to their flying altitude.	22
Figure 2. 7 - Airships division according to their structure.....	22
Figure 2. 8 - Lifting gases comparison in its 100% purity state.	23
Figure 2. 9 - Sky Station platform proposal.	25
Figure 3. 1 - Distances between cities.	31
Figure 3. 2 - Case 1 (left) and Case 2 (right).	31
Figure 3. 3 - Solution for the placement of a depot in city 1 according to the TSP.	32
Figure 3. 4 - Final path when applied the TSP.....	32
Figure 3. 5 - Costs of travelling from each city to another.	34
Figure 3. 6 - Final results from implementing the Clarke and Wright algorithm.	35
Figure 4. 1 - Scheme representing the lift types in airships.	39
Figure 4. 2 - Airlander 10 by the British company HAV.	40
Figure 4. 3 - Business model canvas filled.....	42
Figure 4. 4 - Current transportation path taken by company's lorries.	43
Figure 4. 5 - Approximate results of each city's demand for coffee per day.	44
Figure 4. 6- Explanation of how the Clarke and Wright Algorithm works.....	45
Figure 4. 7 - Representation of the solution for Case Study 1.	46
Figure 4. 8 - Distance between each point.....	47
Figure 4. 9 - Scheme of the solution for Case Study 2.	48
Figure 4. 10 - Explanation of the case study in question.	49
Figure 4. 11 - Scheme of the path where the TSP will be used on.....	49
Figure 4. 12 - Economic model representation.	52
Figure 5. 1 - Representation of the different components and their percentages in the cost structure in a leasing financing case.	59
Figure 5. 2 - Representation of the different components and their percentages in the cost structure in an equity financing case.	60

Figure 5. 3 - Graphical representation of the components that add up to the revenues. 60
Figure 5. 4 - Summary of the comparison of the data regarding costs and distance travelled. 64
Figure 5. 5 - Summary of the comparison of the data regarding time travelled. 64

List of Tables

Table 2. 1 - Different definitions given by the authors concerning business models.	9
Table 2. 2 - Comparison between physical characteristics of different means of transportation.	24
Table 2. 3 - Comparison between non-physical characteristics of different modes of transportation.	24
Table 2. 4 - Airship application scenarios, evaluated by the level of operational capacity....	24
Table 4. 1 - Detailed technical data from Airlander 10.	40
Table 4. 2 - Road freight distances between each point in km.	43
Table 4. 3 - Distances between each point in a straight line in km.	43
Table 4. 4 - Tons of extra coffee freighted per week.	50
Table 4. 5 - Distances in kilometres for the first 10 months of Case Study 3.	51
Table 4. 6 - Costs and Revenues of using the Airlander 10 as a logistics solution.	54
Table 4. 7 - Summary of the results delivered by the business plan.	56
Table 5. 1 - Results from the comparison of each case study to the company's used road transportation.	62
Table 5. 2 - Costs and Revenues of the using the Airlander 10 as a logistics solution with 682 flight-hours per year.	62

List of Acronyms

CWA	Clarke and Wright Algorithm
CC	Coffee Company
DELAG	Deutsche Luftschiffahrts-Aktiengesellschaft
GCD	Great Circle Distance
HAV	Hybrid Airship Vehicles
LEMV	Long Endurance Multi-intelligence Vehicle
NNR	Nearest Neighbor Rule
TSP	Travelling Salesman Problem
UAVs	Unmanned Aerial Vehicles
USA	United States of America
WWI	World War One

Chapter 1

Introduction

1.1 Motivation

1.2 Object and Objectives

1.3 Dissertation Structure and Methodology

1.1 Motivation

Nowadays people are faced with information that they should avoid as much as possible fossil fuels. The most used one is petroleum which is the major origin of environmental problems like acid rains, global warming, oil spills and ocean acidification which end up causing devastation both in fauna and flora and decrease our life's longevity and quality. As depicted from Figure 1.1 transportation is where the main problem resides. Therefore it must be the first one to be analysed.

By Sector, 1949–2016

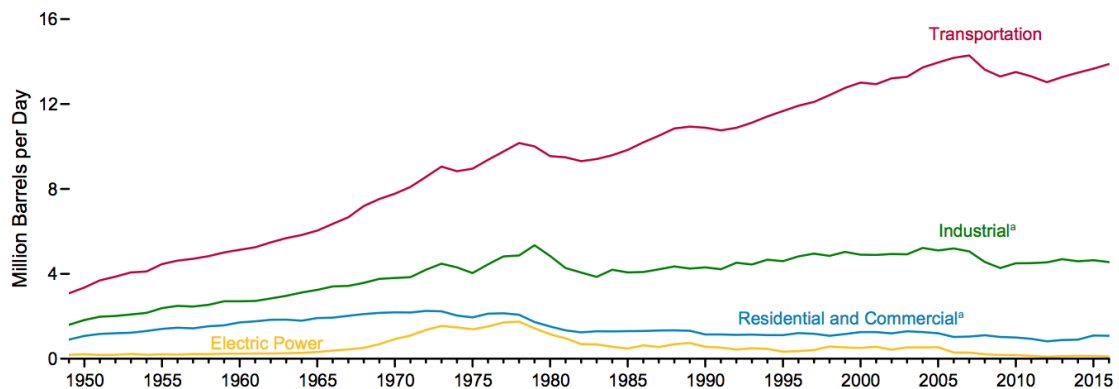

Figure 1. 1 - Usage of petroleum in the different fields in the USA.

Source: [1].

The traffic intensity in cities, especially in the central areas, is the main responsible for the reduction of daily dislocations and the increase of their timing, therefore raising the cost of transportation and jeopardising the retailing.

The product delivery, mainly in the food industry, is made by different operators in the same days of the week, privileging the morning periods which will then result in a traffic congestion of goods, because of multiple loading/unloading happening at the same time. In specific periods of the year (with emphasis on Christmas), the passengers and goods' circulation, which will worsen even more its distribution. In more central areas the urban morphology will difficult the traffic's flow and the loading/unloading; thus, causing an access interdiction to vehicles trying to reach some establishments located there.

Freight companies are forced to change the delivery's schedule and organisation to mitigate the difficulties, resulting in more expenses.

A forecast made by Boeing in 2016-2017 shows that the RTKs¹ will triple in 20 years (Figure 1.2). Thus bound to the fact that the world’s population is increasing rapidly and therefore logistic problems will grow, the question is: What can be done regarding transportation to solve this issue, while still responding to the boost of the population and therefore freight logistics?

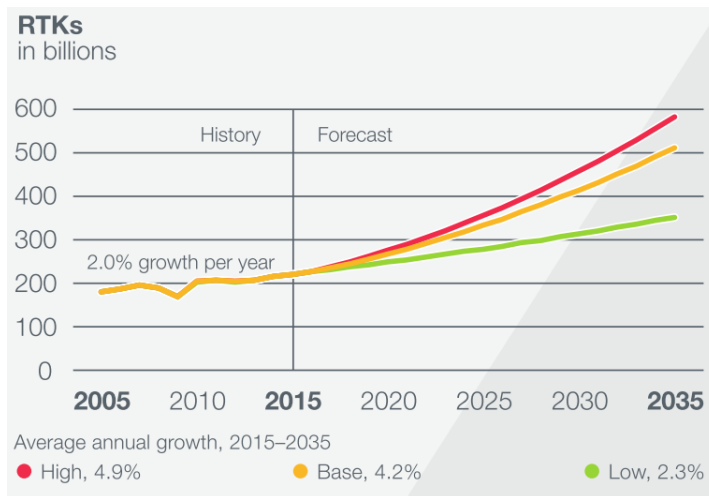

Figure 1. 2 - Boeing world air cargo forecast 2016-2017.

Source: [2].

By addressing this question and based on Figure 1.3 the obvious answer to fill the gap presented is airships as they are the midpoint regarding speed and fuel consumption. Although they are not exactly a new type of transportation and have been around for some time, they are innovative and major companies have started to invest and notice this market niche of the market.

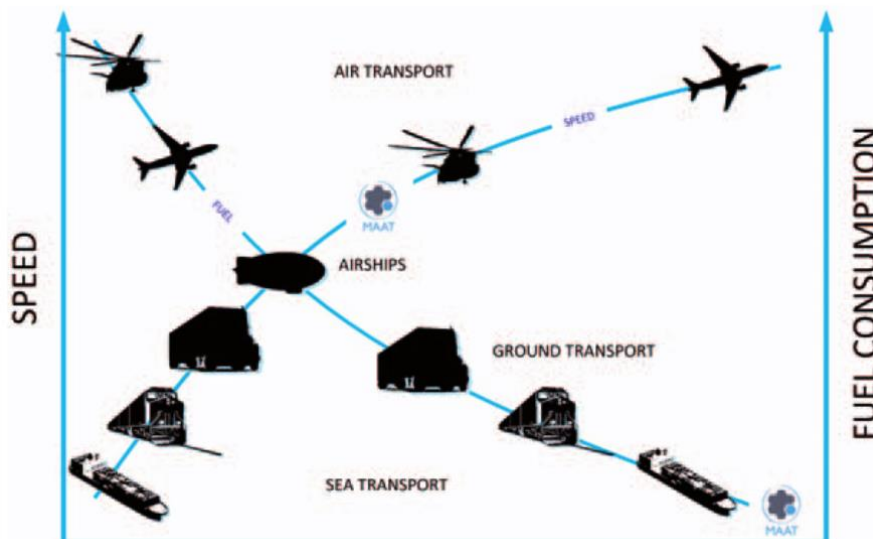

Figure 1. 3 - Fuel consumption and speed according to each type of transportation.

Source: [3].

¹ RTKs are a standard industry metric used to quantify the amount of revenue generating payload carried, considering the distance flown. RTKs comprise the passengers, freight and mail carried multiplied by the Great Circle Distance (GCD), which is a standard published distance between two airports.

1.2 Object and Objectives

The object of this work is an airship for logistics; the objective is to analyse and evaluate the technical and economic viability of a business model for this scenario. There are a certain number of sub-objectives to be accomplished to attain this, such as the airship type assessment, to evaluate the economic impact it may have when it is implemented, and according to the existing technology if it is adequate to today's freight logistics demands in a market niche.

1.3 Dissertation Structure and Methodology

This dissertation is divided into six chapters.

The first chapter consists of an introduction to the theme, as well as a description of the objects and objectives, including an explanation of the methodology used.

Chapter two focus a state of the art and literature review regarding business modelling, freight logistics, air cargo transportation and airships.

The third chapter presents and explains the most suitable algorithms for a network optimisation that will be used to sustain the case study, mainly: the Travelling Salesman Problem, and the Clarke and Wright Algorithm.

Chapter four depicts the results attained that will determine if our proposal is a successful business, both technically and financially, based on several critical parameters: the main airships' characteristics and cargo type, the business model and plan, and the contextualization of the case study and optimal solutions to be adopted.

The fifth chapter focused on the results analysis, mainly: the business plan, and the comparison between road and airship solutions for the transportation of goods.

Chapter six presents the dissertation conclusions, including some final remarks and few recommendations for future research.

Figure 1.4 evidences the strategy used to address this dissertation.

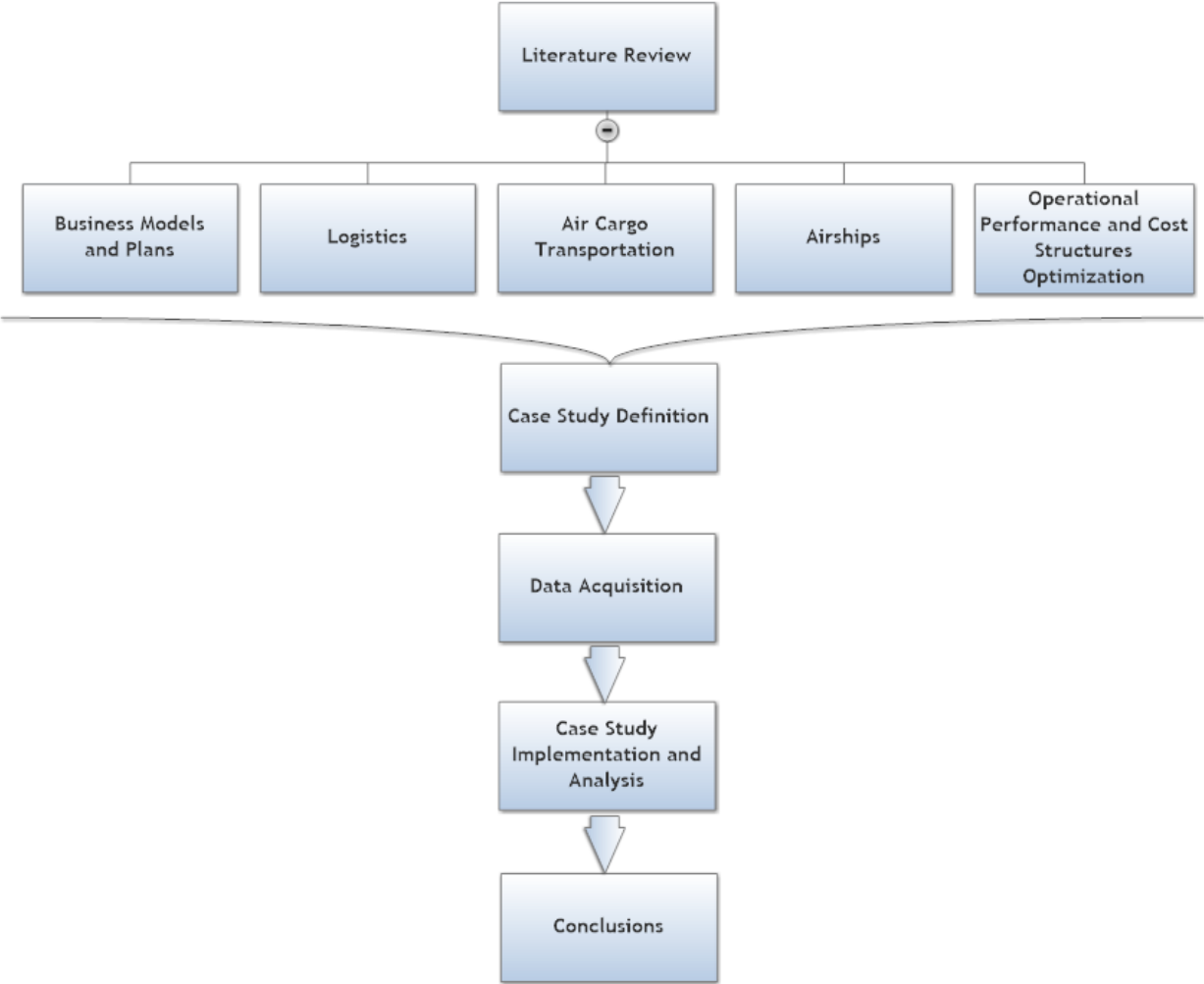

Figure 1. 4 - Scheme of this thesis methodology.
Source: own elaboration.

Chapter 2

State of the Art - Literature Review

2.1 Introduction

2.2 Business Models

2.2.1 Osterwalder and Pigneur's Business Model Canvas

2.2.2 Business Plan

2.3 Logistics

2.3.1 Introduction

2.3.2 Market Segments

2.3.3 Market Regulation

2.3.4 Agents and Stakeholders

2.4 Air Cargo Transportation

2.4.1 Introduction

2.4.2 Special Cargo

2.4.3 Goods

2.5 Airships

2.5.1 History Note

2.5.2 Types

2.5.3 Application Examples

2.6 Conclusion

2.1 Introduction

This chapter provides a general state of the art and literature review concerning business models and plans linked to the airships use for logistics. It starts with a brief introduction to air cargo transportation focusing on airships and their role in today's freight transportation. Considerations regarding logistics and business models and plans were taken to achieve so and how to construct a better solution to test that hypothesis. Linking all these concepts together is a major step in recognising the importance of the airships to start a business as is suggested.

The original idea was to adopt an airship for freight in a broad logistics concept, that is in an urban environment, with several cargo types. Nonetheless, the idea revealed itself not so feasible when we began trying to disaggregate cargo, and the short travelling legs of the distribution network were not appropriated to fit the expected (even preliminary) results. Therefore, the urban logistics concept was abandoned, and a logistics chain with the distribution of a unique cargo type was chosen.

2.2 Business Models

Although it has become a generalised expression in the aftermath of the dot.com companies' boom, it is not easy to find a consensual definition of what a Business Model should be. [4:662] for instance consider it as a cause "trying to differentiate a business model as a term from a strategy notion"; on the other hand [5:206] states that one of its probable causes is the "interest in the concept by a vast number of segments that can relate to this term". Nonetheless, the only foregone conclusion one can have is that there is no universal definition of this concept, as seen in Table 2.1.

Table 2. 1 - Different definitions given by the authors concerning business models.

Source: adapted from [4].

Author(s) and year	Definition
Afuah (2004:2)	"A business model is a framework for making money. It is the set of activities which a firm performs, how it performs them and when it performs them to offer its clients the benefits they want and to earn a profit."
Amit and Zott (2001:511)	"A business model depicts the content, structure and governance of transaction designed to create value through the exploitation of business opportunities."
Johnson et al. (2008:52)	Business models "consist of four interlocking elements that, taken together, create and deliver value". These are customer value proposition, profit formula, key resources, and key processes.
Magretta (2002:1)	Business models are "stories that explain how enterprises work."
Teece (2010:174)	"A business model articulates the logic, the data and other evidence that support a value proposition for the customer, and a viable

	structure of revenues and costs for the enterprise delivering that value.”
Osterwalder & Pigneur (2010:4)	“A business model describes the rationale of how an organisation creates, delivers and captures value.”
Chesborough and Rosenbloom (2002:1)	The business model is “the heuristic logic that technical potential with the realisation of economic value.”

2.2.1 Osterwalder and Pigneur’s Business Model Canvas

Osterwalder and Pigneur defend that “the starting point of any good discussion, meeting or business innovation related workshops must be a common knowledge what a business model really is”. They even defend that it is necessary to define a “model”, in a “way for everyone to understand it”, i.e., a model which is simultaneously “simple, relevant and intuitive”[6:15].

Osterwalder and Pigneur have developed a business model description method composed of “nine basic blocks that show how a company intends to make money. The nine blocks cover the four main areas of business: customer, offer, infrastructure and financial viability”[6:15]. The nine basic blocks are as follows[6:15]:

- **Customer Segments:** Everyone in the organisation which serves and creates benefits. (“For whom are we creating value? Who are our most important customers?”);
- **Value Propositions:** Seeks to solve customer’s problems satisfying their needs with value propositions, that is products and services create benefits for clients. (“What do we deliver to the customer? Which one of our customers’ problems are we helping to solve? Which customer needs are we satisfying? What bundles of products and services are we offering to each customer segments?”);
- **Channels:** Value propositions delivered to customers through communication channels, distribution, and sales. (“Through which channels do our customer segments want to be reached? How are we reaching them now? How are our Channels integrated? Which ones work best? Which ones are the most cost-efficient? How are we integrating them with customer routines?”);
- **Customer Relationships:** Relationships established and maintained with each customer segment. (“What type of relationship does each of our customer segments expect us to establish and maintain with them? Which ones have we established? How costly are they? How are they integrated with the rest of our business model?”);
- **Revenue Streams:** Result from value propositions successfully offered to customers. (“For what value are our customers really willing to pay? For what do they currently

pay? How are they currently paying? How would they prefer to pay? How much does each revenue stream contribute to the overall revenues?”);

- **Key Resources:** Assets required to offer and deliver the previously described elements. (“What key resources do our value proposition require? Our distribution channels? Customer relationships? Revenue streams?”);
- **Key Activities:** Activities which undeniably will have to present a good performance, by accomplishing some key activities. (“What key activities do our value propositions require? Our distribution channels? Customer relationships? Revenue streams?”);
- **Key Partnerships:** Several activities are negotiated with third parts, and some resources are (or can be) acquired outside the company. (“Who are our key partners? Who are our key suppliers? Which key resources are we acquiring from partners? Which key activities do partners perform?”);
- **Cost Structures:** The business model’s elements are the result of cost structures. (“What are the most important costs inherent in our business model? Which key resources are the most expensive? Which key activities are most expensive?”).

These nine blocks, when aggregated, depict a business tool called “Business Model Canvas” (Figure 2.1).

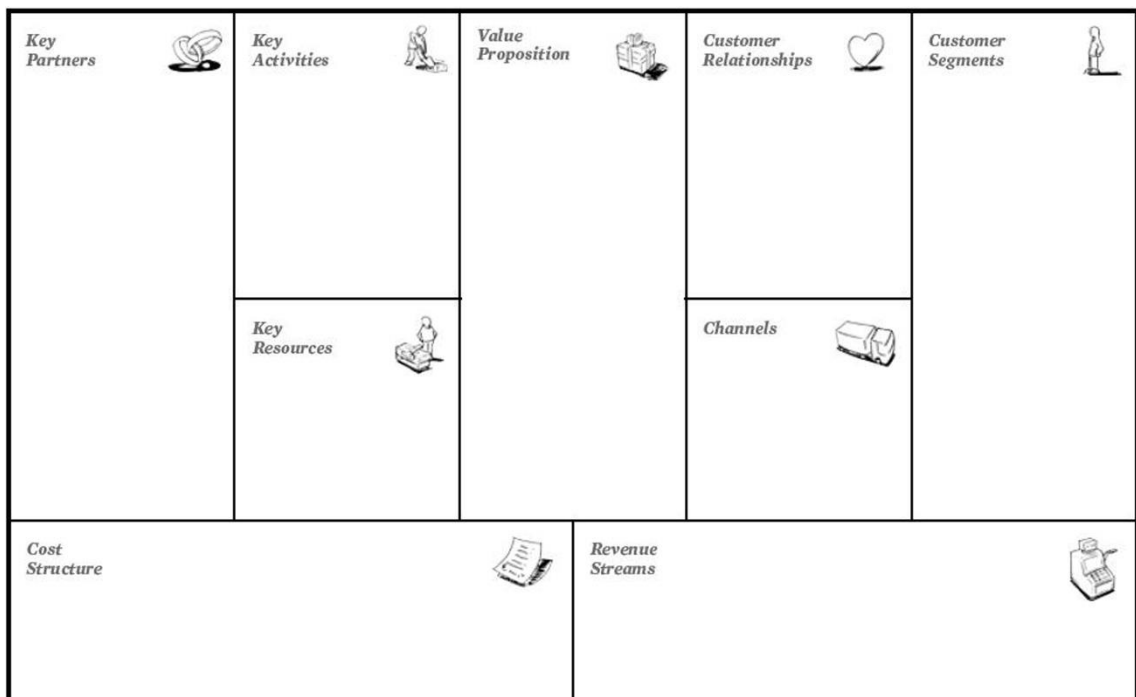

Figure 2. 1 - Business Model Canvas.

Source [6].

2.2.2 Business Plan

Business plans are a written narrative that describes what the new activity intends to fulfil. They normally have two different uses: inside and outside the company. Inside the company, the plan helps to develop a “roadmap” with the steps to follow while the plan and strategies are implemented. Outside the company, it gives to the potential investors and stakeholders the business opportunity that the company strives for and how it plans to do so [7].

When well-perceived, the business plan provides a path for any new or pre-existing business to profit. There are essentially three benefits of having a carefully written business plan [8]:

- It serves as a guide for the business as it provides the tools that allow a business analysis and implementation of changes to make the business as profitable as possible and should be kept updated;
- It is crucial as documentation for financing as it contains a detailed strategy of what the stakeholder proposes to do to improve the company’s profitability; it is also essential for the leader if he/she had access to other company’s statistic data to understand if the own proposed projections are reasonable;
- It is essential to expand into foreign markets as it demonstrated how the business could compete with existing ones in the global economy; this should not be overlooked since it has potential to make the company grow and further increase success.

2.3 Logistics

2.3.1 Introduction

The definition of logistics is “the process of coordinating the flow, material and information, for point dealer to point consumer, effectively and efficiently, according to customer needs”[9:2]. Alternatively, it can be seen as o mean to “target the analysis, planning, and management of integrated and coordinated physical, informational, and decisional flows within a potentially multi-partner value network” [10:2].

Logistics is a tool that optimises the already existing production and distribution based on applying management techniques for promoting an increase in efficiency and the companies’ competitiveness. Transportation is the main influence in logistics it occupies one-third of the companies’ costs in logistics. Transportation is required in the entire procedure from the producer to the final consumer and back to the company, which explains why only an excellent cooperation between logistics and transportation can bring advantages to both the company and the customer [11].

The chart in Figure 2.2 depicts the challenges that shippers are facing. Most of the respondents indicated a concern regarding costs cutting in transportation which as expected represents a significant part of the companies' expenses. The study also shows the demand for the new technology and innovation while remaining cost-conscious [12].



Figure 2. 2 - Top challenges faced by shippers.
Source: [12]

The logistics industry is exponentially growing which shows its importance as it induces more international investments and business. Counter-wise, an inadequately planned logistics might decrease the company's profit.

2.3.2 Market Segments

Many economic sectors need to be harmonised for the city's day to day work life. Some of them present the same type of transportation characteristics, as follows [13]:

- Retail - It is divisible in chain retailing (like supermarkets) who get "served through centralised distribution systems" [13:280], and smaller to medium-sized stores. The last ones have a different supplying system since they are not centralised, thus increasing the number of deliveries when compared to the chain retailing (approximately three times superior);
- Consumer shopping trips - This represents any public or private transportation the customers may use from the retailer to their house; it makes up a noteworthy share of all the freight transport energy;

- Couriers, Express and Parcel (CEP) - These are mainly responsible for the transportation of parcels and documents (usually no bigger than 30kg) to each customer's house. However, this type of segments has some problems associated such as "high delivery failures, empty trip rates and a lack of critical mass in areas with limited demand" [13:280];
- Hotel, Restaurants and Catering (HoReCa) - This also embodies a big share of the urban freight traffic as this segment is accountable for the preparation and delivery of foods and beverages to hotels, bars, canteens, and restaurants;
- Construction - Everyday any city has building and repairing activities in offices, houses, roads, and thus the demand is higher for irregular deliveries;
- Waste - All the activities in a city produce waste which needs transportation to be recycled. Recycling waste needs special means of transportation;
- Industrial and terminal haulage - Besides being places of consumption there are goods and materials produced in cities that need distribution. Therefore there is the existence of production and distribution accommodations. "These facilities are commonly found close to ports, airports and rail terminals, which are transit points to regional or global transport networks" [13:281].

In this dissertation, the focus will lie in the first-mentioned market segment, that is, in the retail chain.

2.3.3 Market Regulation

Since the beginning of Humanity, food has been an important aspect of humans' life and health. Thus legislation regarding this matter has become more rigorous due to a more demanding and interested society.

The Portuguese legislation, as well as the international one, for the transportation of food products, states that the freight must be made by an adequate vehicle prepared for such or placed in a convenient container.

When transporting perishable goods (like fresh meat and fish, fresh fruits and vegetables) one must consider low temperatures (below 5 °C) as it is harder for any dangerous bacteria to proliferate in colder environments.

Transporting nonperishable goods offers fewer problems and less necessary extreme cares as they are not as easily contaminated as those above. The main consideration is when storing,

keeping them in a dry place with little to no likelihood of temperature oscillations, responsible for causing container sweat².

As far as goods transportation is concerned, the Portuguese legislation is harmonised with the European ones: Regulations (EC) 852/2004 and 178/2002 [14]-[16].

2.3.4 Agents and Stakeholders

In spite being overlooked, Agents and Stakeholders are important concepts in logistics as they can impact (most of the times negatively) on urban freight (Figure 2.3) as follows [17]:



Figure 2. 3 - Agents and stakeholders in freight logistics.

Source [17].

- **Public Authorities:** There are three levels of authorities: local government, national government, and an international government (like the European Commission). A local government may refer to a set of regional/metropolitan agencies and municipalities; if so their coverage will be bigger than just one municipality and thus they should cooperate to ensure an excellent logistics service. The international and national authorities create adequate legislation and promote the cooperation between national and international regions and municipalities;
- **Producers & Shippers:** They prepare the goods, that is, by packing and delivering them. As stakeholders, they impact logistics as “they may rework their packaging styles in cooperation with transport companies, resulting in higher loading capacity” [17:15]; in

² Container sweat is the condensation that naturally occurs in closed environments (for example a shrink-wrapped pallet).

the cases of running an exclusive fleet of vehicles they can account up to 30% of urban deliveries;

- Wholesalers: Being a stakeholder in-between Producers and Receivers they are responsible for buying large quantities of goods in bulk and re-selling them to the retailers. Wholesalers are accountable for the “rationalisation of the number of vehicles and transport kilometres since they promote the concentration of flow in a reduced number of locations”[17:15]. Liable for freight flow control, these are the most knowledgeable stakeholders in what the market is concerned;
- Freight Transport and Logistics Operators: These are answerable for the physical movement of goods between locations; simultaneously they work as invoices and billing placers, warehouses providers and inventory managers. The stakeholders mentioned above can be like wholesalers as they “collect and bundle freight flows from different producers”[17:15] before making its distribution. This market of freight transportation tends to be heterogeneous as the size of the enterprises ranges from small family-run companies (with a small fleet of vehicles) to large international companies (with fleets of hundreds of vehicles);
- Receivers: They are dispersed in the urban and non-urban areas and are directly linked to logistics services; as small retailers, often they have vehicles to attend to the wholesalers. These vehicles are also used for leisure and business travels. Nonetheless the receivers “are not responsible for freight transport since shipments are organised and paid for by the shipper”[17:16];
- Residents and Users: These stakeholders are people who spend most of their time in the urban area whether it is in leisure activities, shopping or working. Unfortunately, logistics services come with many unwanted results such as emissions, smells, noises and vibrations, which don’t go up to the quality life of these residents’ expectations. Lately, a new trend is rising, e-commerce and home delivery which worsen all the problems mentioned above;
- Others: This class contains the “so-called resource supply stakeholders, including investors, infrastructure providers, and managers [...], landowners, and providers of vehicles or information technologies (IT) support systems.” [17:17]. These stakeholders are directly linked to the investments and innovations that allow the possibility for freight transport to evolve.

2.4 Air Cargo Transportation

2.4.1 Introduction

After World War II there was an increase in the volume of goods freighted, which was due to a boom in the globalisation of the world's economy thus providing more attention to the ways the freight was made.

In the specific case of air transportation freight, the three top groups responsible for this activity are airlines, integrators and forwarders [18].

Airlines do not deal directly with customers, and so they can be divided into two broad categories: combination and all-cargo carriers. Combination carriers transport either passengers or freight on the main deck of an aircraft. All-cargo carriers include integrated freight and dedicated freight carriers (airlines that operate only freight aircraft with no scheduled passenger services).

Integrators are the ones who handle shipment from origin to destination and deal directly with customers. They combine all operations of freight shipping into one business (includes road carriage, freight forwarding and air transportation).

Lastly, forwarders are an intermediary who connects the importer, exporter or other involved companies or persons in shipping goods and organising the transportation in a safe and cost-efficient way. They are essentially the middle-man who link the shipper, the airline and the consignee (the entity responsible for receiving the shipment) [19].

2.4.2 Special Cargo

In freight, it is recurrent that not all the items are consistent regarding size and weight, and the fact that they differ dictates that a different transportation method should be applied to particular (special) cargos.

There are many and distinct reasons why sometimes cargo can be considered difficult to transport, whether it is due to rural destinations having improvised means of access or simply not fitting for a normal plane, lorry, or ship. Some freight companies have been faced with very difficult, near impossible, cargo that requires special planning and arrangements.

Global Shipping Services is an example of the difficulties mentioned above: it has had some complicated cases such as moving large and heavy compressors and coolers from Texas (USA) to Mumbai (India) in a schedule as tight as four working days using a lorry and ship freight to accomplish this mission [20]. Others special cargo included moving two Cobra Attack Helicopters from Aqaba (Jordan) to Alabama (USA) which was achieved in 24 days [21] or

shifting overhead gantry cranes from West Bengal (India) to Illinois (USA) using the same freight combo as mentioned above [22].

CAL Cargo Airlines is another example of specialised airline in special cargo freighting by air, whether it is perishables, live animals, pharmaceuticals, dangerous goods, valuables, or oil and gas engines. In some of the cases, the temperature is critical in maintaining the properties of such products (this is a special characteristic of pharmaceuticals, live animals and perishables). The maximum payload is also an important attribute to consider when shipping an oversized or overweighed item like turbines, helicopters, yachts, electric poles, luxurious automobiles or Unmanned Aerial Vehicles (UAVs). Another unusual cargo that needs particular attention while being manoeuvred and transported are dangerous goods as they range from magnetic to radioactive, corrosive to explosive, flammable liquids to infectious substances; the handler needs to be certified to obtain the least amount of tarmac time³ possible [23].

2.4.3 Goods

The first ever goods market was the spice trade from as early as 3000 BC between Asia, Northeast Africa and Europe. Firstly made by camel caravans and later exchanged to sailing ship, there was an improvement in this trade between Europe and East Asia. Hundreds of years later steam-powered marine transportation enabled a faster connection between continents. Subsequently, it allowed the advancement of freight railways and refrigerators enabled the trade of frozen meats and dairy products globally.

The air transportation of perishable goods was the last type to enter this distribution market, and although it is important, mostly in long-distance markets (shipment of fresh flowers, seafood, and high valued tropical fruits), the share of volumes of air shipments of perishable goods are smaller when compared to the world production.

Figure 2.4 depicts the relation between product values and shelf life and relates it to the most appropriate means of transportation. Thus the fresher and more perishable the cargo the faster it needs to be shipped, so air transportation (nowadays made by aeroplane) is the preferred means of transportation. On the other hand, items with longer shelf life such as grains, root crops and some fruits are transported via ships; this leaves a gap for some fresh fruits and meats which find themselves in-between the spectrum of transportation, thus the consideration of airships as an answer to this problem.

³ Tarmac time is a term used to describe the time spent on taxiways and runways.

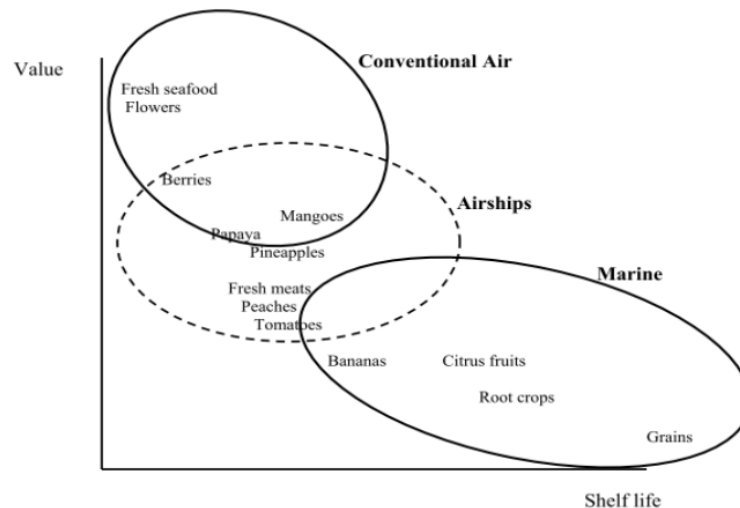

Figure 2. 4 - Value, shelf life, and dominant transport modes in intercontinental movements of food products and ornamentals.

Source: [24] as cited by [25].

2.5 Airships

2.5.1 History Note

An airship is a “form of mechanically driven aircraft, lighter-than-air, having a means of controlling the direction of its motion” [26] as cited by [27:17].

The earliest stated events of this kind of “flight” include the Kongming lanterns from the Three Kingdoms Era. These events took place in China from 220-280 AD, and they were simple airborne hot air lanterns used for military signalling.

Airship shaped vehicles were employed in experiences like the one conducted by the Brazilian-Portuguese Jesuit priest and scientist Bartolomeu de Gusmão, in 1709, who is pointed out as the first airship builder. Though many opinions outside the Portuguese and Brazilian communities do not recognise this claim, his work was so remarkable that 75 years later it was used by the Montgolfier brothers; Étienne Montgolfier was the first human being ever to fly (although it was a tethered⁴ flight).

The first dirigible airship was built in 1856 by Henri Giffard (Figure 2.5); until then airships depended quite exclusively on climate conditions for steering. Almost half a century was spent in experiences until Alberto Santos-Dumont built and flew the “Number 6”, the first-ever gasoline propelled airship.

⁴ Tethered means fastened with a rope or cable to the ground.

The creation of the first airline, in 1909, is as well due to airships; its name was Deutsche Luftschiffahrts-Aktiengesellschaft (DELAG), a German Airship Travel Corporation. As the World War I (WWI) just began, there was a burst of the airships business and construction. Mainly they were used for reconnaissance (playing over 1000 missions), even though soon there was the realisation that they were extremely vulnerable to ground fire at low altitudes and, therefore not crucial in a war scenario. Even so, they were still responsible for over 500 deaths in bombing raids all over Great Britain.

The WWI reaches its end, in 1918, and so do with the German military airships; nevertheless soon (one year later) the passengers' transportation using airships began between Friedrichshafen and Berlin.

In 1929 the first long-awaited circumnavigation trip was completed, which took about 21 days.

The world's biggest and best-known airship, Hindenburg or LZ 129, unfortunately, crashed on May 6th, 1937 causing a total of 36 casualties, just one year after its first flight. This airship was being used as a transatlantic transporter, and the disaster was considered the end of airships. The biggest problem with this event was the fact that at that time, the gas used to fill the airships was hydrogen (highly flammable) instead of helium. Goodyear precisely did so since 1925, but the USA had the monopoly of the helium production since before the war.

In the last decade of the XX century, the Zeppelin NT delivered a semi-rigid airship used mainly for aerial tourism, environmental research, and advertising purposes. In 2016 news was flooded about airships because Hybrid Airship Vehicles (HAV) developed the Airlander 10 (formerly a project for the USA military sector) that crashed against the floor in Bedfordshire during its second flight.

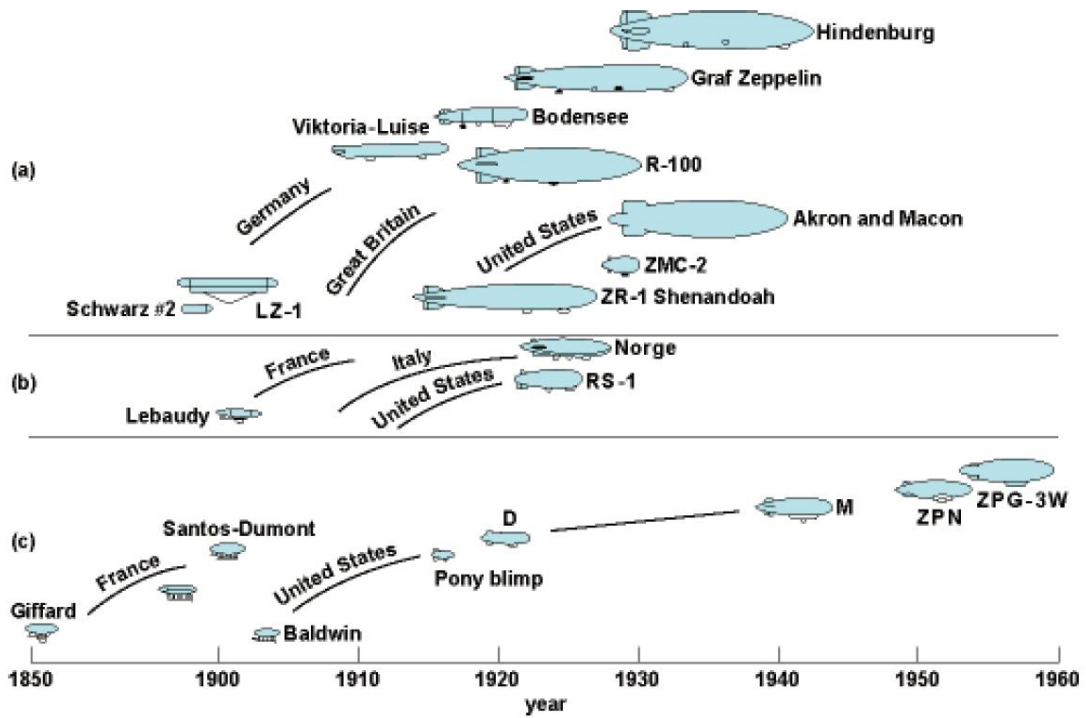

Figure 2. 5 - History of airships according to their type from 1850 until 1960 divided by structure types: rigid (a), semi-rigid (b) and non-rigid (c).

Source: [28].

2.5.2 Types

Airships can be classified regarding the altitude they can reach and the internal structure shape. According to its operation altitude, the airships will have different applicability as stated in Figure 2.6.

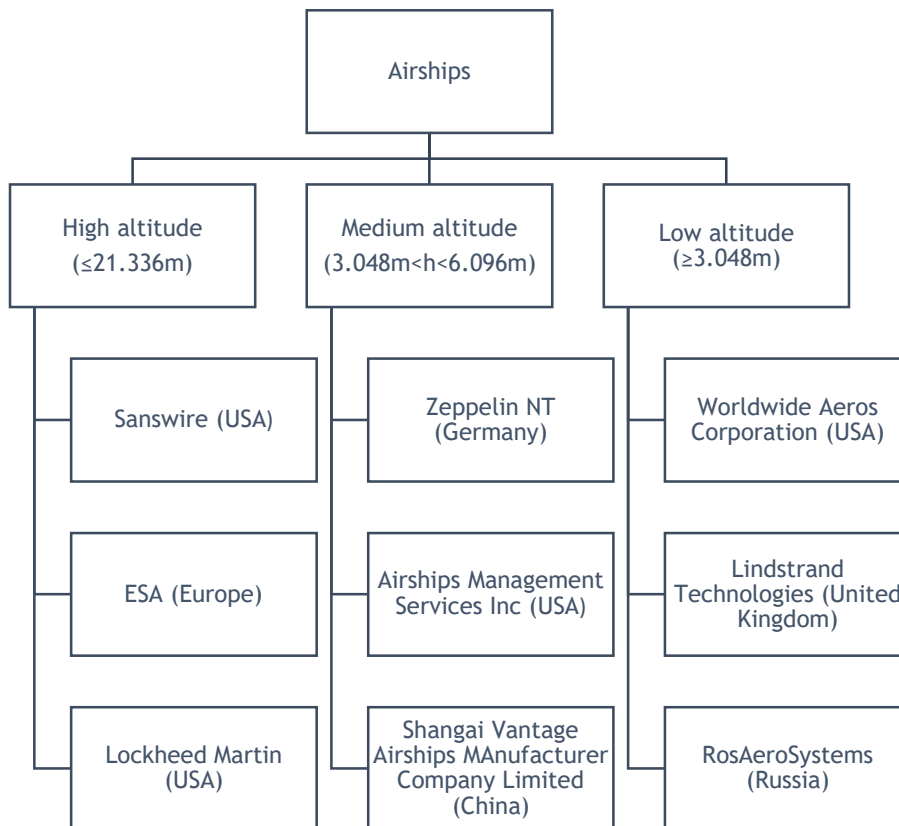

Figure 2. 6 - Companies that manufacture airships according to their flying altitude.

Source: [29].

According to the internal structure, shape airships can be divided into three categories as depicted in Figure 2.7: rigid, semi-rigid and non-rigid.

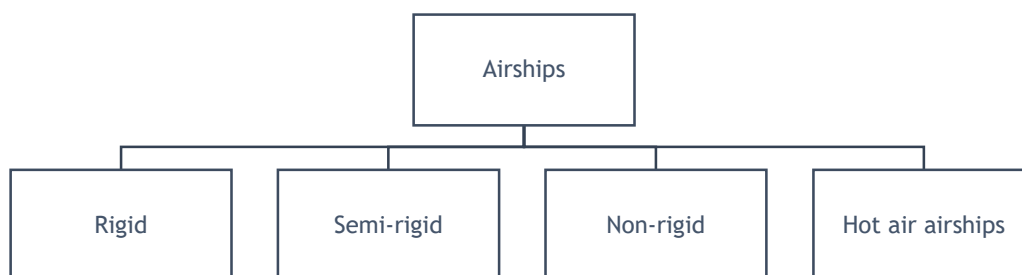

Figure 2. 7 - Airships division according to their structure.

Source: [29].

Rigid airships can keep their shape with the help of a full framework structure made of metallic spars and ribs; these will hold most loads placed in the airship instead of in the envelope, which makes the envelope’s material less likely to tear, thus providing more liability and fewer

chances of happening any accident. The main problem with this type of airship structure is the weight associated, alongside with the price and the complexity of the manufacturing process.

Semi-rigid airships are the in-between class. They can be classified as the best of both worlds as they have structure and internal gas pressure keeping its shape. They have a rigid keel where the gondola, the fins (stabilisers) and the hull are usually attached. The usage of ballonets is necessary to control the internal pressure and thus it is possible to change the airship's altitude as the gas bags inflate or deflate according to the pilot's needs.

Non-rigid airships also referred to as blimps, have nothing but overpressure (made possible by gas inflation), keeping its shape. These are the less expensive and less time-consuming airships regarding production and manufacturing, but this simplicity also brings more safety issues since it is less trustworthy and more unstable. The "hot air" airships differ from the non-rigid ones as the inflating gas is heated air instead of helium or hydrogen.

Excluding the "hot air" airships all the others tend to use helium as inflating gas, mainly because helium is the second most lifting of the seven-gases considered (Figure 2.8). The hydrogen is a dangerous option as it is very flammable; hydrogen was the cause of several accidents like that of Hindenburg in late thirties [28].

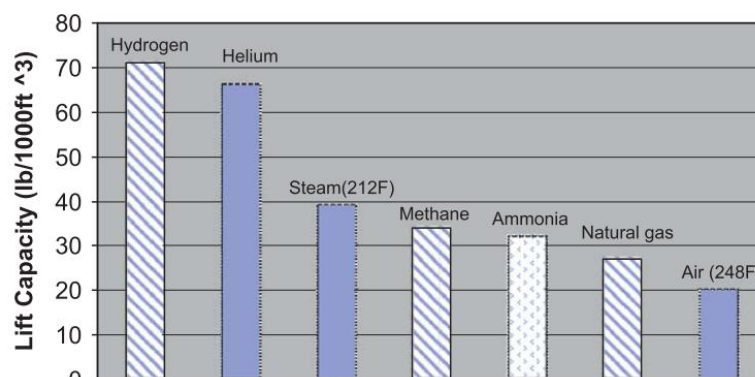

Figure 2. 8 - Lifting gases comparison in its 100% purity state.

Source: [28].

2.5.3 Application Examples

Nowadays perhaps amongst all the means of transportation, the airship seems to be the least mentioned one. However, some governments and companies appear to be interested in the advantages that these air vehicles can provide; the fact that every year new related projects keep arising is a clear sign that times are changing for airships. Looking at the following tables (Table 2.2, Table 2.3, and Table 2.4), we can deliver several reasons to be optimistic about the future of such a mean of transportation.

Table 2. 2 - Comparison between physical characteristics of different means of transportation.

Source: [30].

	Lorry	Railway	Ship	Airplane	Helicopter	Airship
Cost of vehicle	2	4	4	5	3	3
Speed	2	3	2	5	4	4
Capacity	2	5	5	3	1	4
Range	2	3	5	4	3	4
Fuel consumption per km.	3	3	2	5	4	2
Infrastructure requirements	5	4	3	3	2	1
Green House Gases requirements	4	2	1	5	5	2
Maintenance Cost	4	3	3	4	4	2
Life Time	2	4	4	3	3	4

Scale:	1- Very Low	2- Low	3- Medium	4- High	5- Very High
--------	-------------	--------	-----------	---------	--------------

Table 2. 3 - Comparison between non-physical characteristics of different modes of transportation.

Source: [31].

	Lorry	Railway	Ship	Airplane	Helicopter	Airship
Use in publicity	3	1	1	1	1	5
Reliability	2	3	3	5	2	4
Usability in urban areas	4	3	1	2	4	5
Number of competitors	5	2	3	2	4	1
Traffic	5	3	2	2	2	1
Noise pollution	5	3	1	2	2	1

Scale:	1- Very Low	2- Low	3- Medium	4- High	5- Very High
--------	-------------	--------	-----------	---------	--------------

Table 2. 4 - Airship application scenarios, evaluated by the level of operational capacity.

Source: [29].

Application Scenarios	High Altitude Airship	Medium Altitude Airship	Low Altitude Airship
Defence	High	Medium	High
Anti-Ballistics Platform	High	Low	Medium
Research and Data Transmission	High	High	High
Telecommunication	High	High	High
Wireless Communications, GPS, etc.	High	Medium	High
Surveillance	High	High	High
Scientific Research	High	High	Medium

Monitoring	High	High	High
Patrol	Medium	High	Medium
Tourism and Publicity		High	Medium
Cargo and Passengers' Transportation		High	Low

One of the first stated uses for airships, other than surveillance or weapons transportation, was aircraft carrying as done by USS Macon: this airship had a hook attached to its envelope that would hold up to five Curtiss F9C Sparrowhawk (a biplane fighter aircraft).

Another problem that can be solved with airships is the case of using a tethered aerostat to provide internet access to remote areas. A study was conducted by “having a central base village providing internet connectivity to neighbouring villages” [32:6] to test out if it was feasible technically and economically. The fact that the system would be relocatable, translates into far fewer installations required, and there is only the Archimedes Principle keeping its height (no additional energy supply required) [32].

In respect to tourism, a study was conducted in Portugal, where airborne eco-tourism between the city of Braga and the Parque Natural da Peneda-Gerês was considered proving its viability both technically (evidence of potential clients) and economically (ticket prices determined in comparison with alternative transportation means) [33].

Furthermore, another example of possible use of airships is as an alternative to communication satellites. In this case, airships will be transformed into high-altitude platforms, solar-powered, unmanned, and capable of long endurance missions (at least seven months). Companies like the American Sky Station International (Figure 2.9) and the British Advanced Technology Group have already started planning airships for these activities [34].

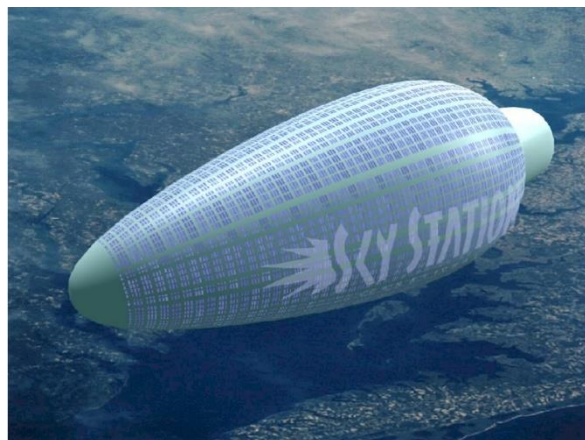

Figure 2. 9 - Sky Station platform proposal.

Source: [34].

Nowadays CargoLifter offers airship-like solutions to problems such as [35]:

- disaster-relief (an airship “costs a fraction of one helicopter and can be in operation for days”, and it can lift the debris from ruins of earthquakes, rescue people from trees and roofs and provide food, water, tents and medical care);
- ship-to-shore transportation (when harbours are too small or too shallow, it aids in “unloading straight from the ship-to-shore at some point close to destination”);
- construction and renovation (airships can replace tower cranes when they are not tall enough, or their maximum lifting power is inadequate to a company’s needs to, for instance, lift a beam); and
- wind turbine transportation solution (a conventional wind turbine consists of a 65 meter and three 36 meter blades for a total of 164 tons, depicting how needless it would be road stretching and/or closing).

2.6 Conclusion

This chapter presents the most important studies and approaches to each concept included in the execution of this project.

The first present concept was business models (which also included business plans) stating its importance in the implementation of any new service, the suggestion given by [6] as it allows a practical and concise application.

The fact that transportation (mainly freight) has been increasing alongside with problems associated with it, has introduced the logistics concept which shed a light on the challenges faced by shippers and how market segments and stakeholders can heavily influence new logistics solutions.

One of those solutions can be using air transportation as an answer to logistics’ problems, therefore, a thorough research was made to understand what has been done so far in terms of goods’ transportation via air.

A different path in terms of the considered classic air transportation was followed and airships were found relevant, being that they are not a new concept a research regarding its different types and structures along with the existing applications of this technology and how it could fit the necessities of today’s logistics.

Linking all these concepts together is crucial to prove the feasibility of this project and what has been done or studied so far.

Chapter 3

Operational Performance and Cost Structure Optimisation

3.1 Introduction

3.2 Travelling Salesman Problem Algorithm

3.3 Clarke and Wright Algorithm

3.4 Conclusion

3.1 Introduction

“Combinatorial analysis is the mathematical study of the arrangement, grouping, ordering, or selection of discrete objects, usually finite in number. Traditionally, combinatorialists have been concerned with questions of existence or of enumeration. That is, does a particular type of arrangement exist? Or, how many such arrangements are there?”[36:1].

The feature that distinguishes discrete or combinatorial optimisation from the linear one is that some variables are part of a discrete set, typically, a subset of integers. It is also known as integer and combinatorial programming [37].

The network analysis emerged as useful in formulating and solving operational research, for instance in communication network (railways, electrical energy, telephones, etc.), task planning and some production or distribution problems as the representation of a system through a network allows a better understanding of the correlations between its elements [38].

3.2 Travelling Salesman Problem

The Travelling Salesman Problem (TSP) considers a set of cities - in one of which the salesman leaves (city-based or depot). He must visit all the cities or a subset of them, and the goal is to optimise one or more objectives (as referred later) mainly the route (distance travelled or the associated costs). TSP is defined in directed and non-directed graphs [37].

There are different heuristics procedures to solve the TSPs:

- The Nearest Neighbour Rule (NNR);
- The nearest insertion rule;
- The Lin’s r-optimal heuristic;
- Christofide’s Heuristic.

The NNR was chosen for this dissertation as it delivers the minimal distance travelled.

Formulation

Considering a complete directed or non-directed graph $G=(N, A)$ being (N) a set of n vertexes and (A) a set of (m) arcs.

Let C_{ij} be the cost or length associated with the arc (i,j) according to one’s needs (whether there is the need to minimise cost or distance). The distance of the circuit is the sum of the lengths associated with the arcs:

$$x_{ij} \begin{cases} 1 & \text{if arc (i,j) is the optimal TSP tour (Hamiltonian Circuit)} \\ 0 & \text{otherwise} \end{cases}$$

$$\begin{cases}
 \min \sum_{i=1}^n \sum_{j=1}^n c_{ij} x_{ij} & (1) \\
 s. t. \sum_{i=1}^n x_{ij} = 1 \quad \forall j \in N & (2) \\
 \sum_{j=1}^n x_{ij} = 1 \quad \forall i \in N & (3) \\
 x_{ij} \in \{0,1\} \quad \forall i, j \in N & (4)
 \end{cases}$$

X_{ij} must form a tour (5)

The last constraint can be written in one of the following forms:

$$\sum_{i \in S_t} \sum_{j \in \bar{S}_t} x_{ij} \geq 1 \quad \forall S_t \subset N \quad (5.a)$$

$$\sum_{i \in S_t} \sum_{j \in S_t} x_{ij} \leq |S_t| - 1 \quad \forall S_t \subset N \quad (5.b)$$

$$\sum_{i,j \in \Phi} x_{ij} \leq |S_t| - 1 \quad \forall S_t \subset N \text{ and all } \Phi \in \chi(S_t) \quad (5.c)$$

Thus,

$\bar{S}_t = N - S_t$ and $|S_t|$ is the cardinality of S_t .

$\chi(S_t)$ is the family of all Hamiltonian circuits of the induced sub-graph.

Let $K_t = (S_t, \bar{S}_t)$ be the set of arcs (i,j) with $i \in S_t$ and $j \in \bar{S}_t$.

The (5a) constraint states that at least one arc in the TSP tour must belong to any arc-cut set K_t of G .

Regarding the constraints (5.b) and (5.c) they are both the expressions of the fact that no sub tour through the subset of vertexes defined by S_t can exist as part of the TSP solution.

The Nearest Neighbour Rule

When applying this rule, one must start with an arbitrary vertex and proceed to form a path by joining the vertex just added to its nearest neighbouring vertex (hence the name) which is not yet on the path, until all the vertexes are visited. In each case, the two end vertexes of the Hamiltonian path are joined to form the TSP solution. The following example illustrates a more practical application of the method.

Example

Considering five different cities with the distances in kilometres between them as represented in Figure 3.1.

Choosing, randomly, to place a depot in city 1, according to the Nearest Neighbour Rule one must check the closest distanced city - which is city 2.

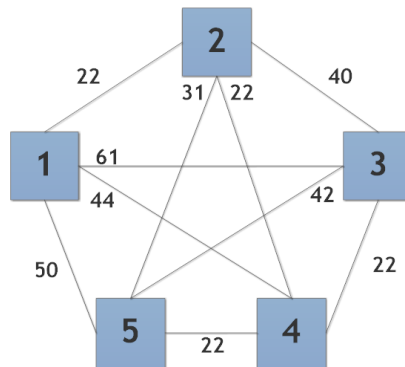

Figure 3. 1 - Distances between cities.

Source: own elaboration.

Then, starting from city 2 the next closest city would be city 4. When getting to city 4 the user faces a problem as both cities 3 and 5 are far from the same distance - 22 km. Therefore both hypothesis must be tested, thus dividing the route's solution into two different ones as depicted in Figure 3.2.

In case 1, since the travelling salesman must attend all the cities and go back to the city-depot, he automatically goes to city 3 and returns from there to city 1. A total of 169 km is achieved.

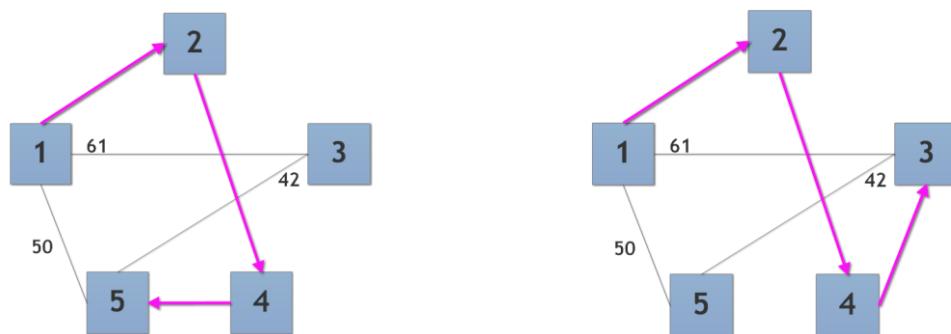

Figure 3. 2 - Case 1 (left) and Case 2 (right).

Source: own elaboration.

Following the rule above, in the case 2, from city 3 the salesman goes to city 5 and ends its path back to the depot. A total of 158 km is achieved.

Comparing the results obtained the most distance effective path is the one shown in Figure 3.3 as it is the one with less distance travelled; it is important to mention that the direction the path is travelled isn't important as it is mathematically the same.

Nonetheless, another hypothesis must be tested regarding depot placement.

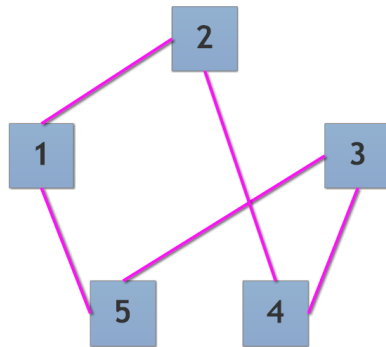

Figure 3. 3 - Solution for the placement of a depot in city 1 according to the TSP.

Source: own elaboration.

Based on NNR it is necessary to experiment all the cities as depot-based to search for the best solution. Following we have the results for each one, including the related sub-routes:

- Depot in 2: associated distances (in km) = 161, 169, 170, 158
- Depot in 3: associated distances (in km) = 158, 158
- Depot in 4: associated distances (in km) = 158, 156, 158
- Depot in 5: associated distance (in km) = 156, 169

Analysing the results, a depot in cities 4 or 5 would be ideal as they represent the shortest path - 156 km. The final path is portrayed in Figure 3.4.

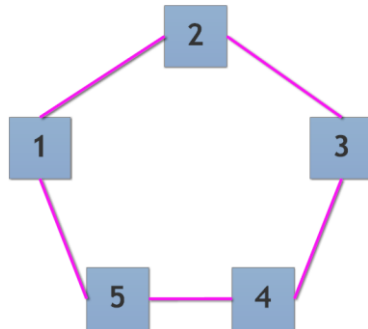

Figure 3. 4 - Final path when applied the TSP.

Source: own elaboration.

3.3 Clarke and Wright Algorithm

Vehicle routing problems are concerned with the delivery of some commodities from one or more depots to some customer locations with known demand. Such problems arise in many physical systems dealing with distribution networks. For example, delivery of commodities such as mail, food, newspapers, etc.. The specific issue which rises is dependent upon the type of constraints and management objective [39].

In the reviewed literature the following features can be found:

- A single commodity is to be distributed from a single depot to customers with known demand;
- Each customer's demand is served by one vehicle;
- Each vehicle has the same capacity and makes one trip;
- The total distance travelled by each vehicle cannot exceed a specified limit;
- Each customer must be serviced within a specified time window;
- The objective is to minimise the total distance travelled by all vehicles.

Formulation

- $K \rightarrow$ set of identical vehicles
- $Q_i \rightarrow$ vehicles' capacity
- $q_j \rightarrow$ cargo
- $P_j \rightarrow$ distribution points
- $P_0 \rightarrow$ depot/warehouse
- $C_{i,j} \rightarrow$ cost/distance between points (vertexes)
- $k \rightarrow$ vehicle

Considering an oriented graph $G=(N, E)$ where $N=C \cup \{0,n+1\}$ being the last part the vertexes that represent the warehouse and $E=\{(i,j): i,j \in N, i \neq j, j \neq n+1\}$ representing E the arcs associated with the connections between the vertexes.

$$x_{ij} \begin{cases} 1 & \text{if the vehicle } k \text{ runs the } (i,j) \text{ arc, } \forall k \in K, \forall (i,j) \in E \\ 0 & \text{otherwise} \end{cases}$$

Nonetheless, if $Q_i \geq \sum q_j$ the case is no longer a Clarke and Wright Algorithm one, if not a Travelling Salesman Problem instead.

The equations associated with the resolution of this algorithm are:

$$\min \sum_{k \in K} \sum_{(i,j) \in E} c_{ij} x_{ijk} \quad (6)$$

$$\sum_{k \in K} \sum_{j \in N} x_{ijk} = 1, \quad \forall i \in C \quad (7)$$

$$\sum_{i \in C} d_i \sum_{j \in N} x_{ijk} \leq Q, \quad \forall k \in K \quad (8)$$

$$\sum_{i \in N} x_{ihk} - \sum_{j \in N} x_{hjk} = 0, \quad \forall h \in C, \forall k \in K \quad (9)$$

$$\sum_{i \in N} x_{ihk} - \sum_{j \in N} x_{hjk} = 0, \quad \forall h \in C, \forall k \in K \quad (10)$$

$$\sum_{i \in N} x_{i,n+1,k} = 1, \forall k \in K \tag{11}$$

$$\sum_{i \in S} \sum_{j \in S} x_{ijk} \leq |S| - 1, S \subset C, 2 \leq |S| \leq \left\lfloor \frac{n}{2} \right\rfloor, \forall k \in K \tag{12}$$

Equation (6) minimises the total routing cost/distance. Constraints (7) and (8) indicate that to each customer (i) a single vehicle (k) is designated and that in the total route cost the vehicle cannot exceed the (Q) vehicle’s capacity. The (9), (10) and (11) constraints assure that each vehicle (k) starts its path at the depot (vertex 0) only once and that only leaves the (h) vertex if and only if it enters that same vertex and returns to the depot. The last constraint (12) guarantees the non-existence of sub-routes [37]. The following example best explains this algorithm.

Example

Let’s consider D as a depot or warehouse and that a vehicle must attend cities 1 to 5, that the red numbers stand for the demand of each city, and that there is only one vehicle with a capacity of 25 tons. Thus Figure 3.5 depicts the costs (distances) from the warehouse to each city (left) and the associated table (right) the costs (distances) among cities.

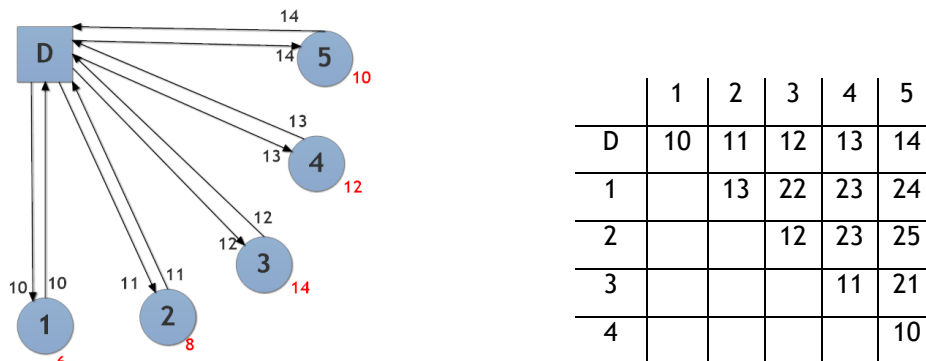

Figure 3. 5 - Costs of travelling from each city to another.

Source: own elaboration.

The algorithm calculates how much is the saving to joint the depot (always) with each pair of cities in the same route. For instance, to join the depot and cities 1 and 2, we will save one trip between the depot and city 1 and another trip between the depot and city 2; but we will spend a (new) trip between cities 1 and 2, to complete the route. For this example, the equations and the related savings (“p - poupanças”, in Portuguese) obtained are as follows:

$$p_{12} = 10+11-13 = 8$$

$$p_{13} = 10+12-22 = 0$$

$$p_{14} = 10+13-23 = 0$$

$$p_{15} = 10+14-24 = 0$$

$$p_{23} = 11+12-12 = 11$$

$$p_{24} = 11+13-23 = 1$$

$$p_{25} = 11+14-25 = 0$$

$$p_{34} = 12+13-11 = 14$$

$$p_{35} = 12+14-21 = 5$$

$$p_{45} = 13+14-10 = 17$$

The biggest saving is for cities 4 and 5 and since the demanded sum (22 tons) for both cities is below the cargo limit (25 tons) of the vehicle, this connection is feasible. Thus, it will be not possible to join any other city to this pair as there is no other city with a demand to fill the vehicle capacity gap still available. Moreover, the depot and cities 4 and 5 form a route/circuit. For the algorithm, this is a solved problem, and it is necessary to search for other possibilities of savings involving the remaining cities.

The next best possibility for saving is connecting cities 2 and 3 (once again the demand for both cities is below the vehicle's capacity) leaving out city 1 to be supplied alone.

Figure 3.6 depicts the final result.

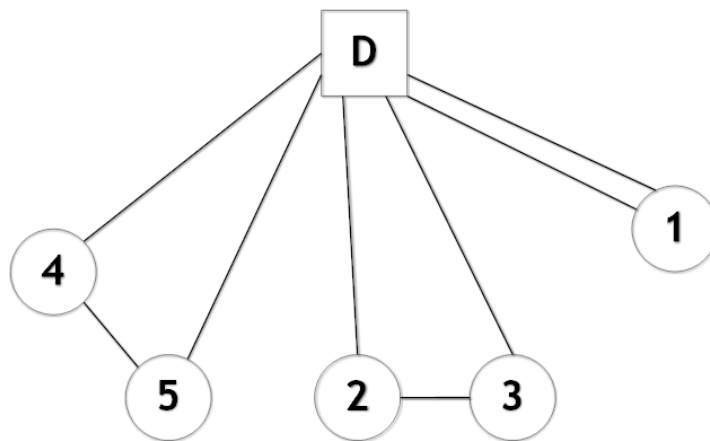

Figure 3. 6 - Final results from implementing the Clarke and Wright algorithm.

Source: own elaboration.

The subcircuit cost involving the depot and cities 4 and 5 means 37 km, the subcircuit cost involving the depot and cities 2 and 3 means 35 km, and the subcircuit cost involving the depot and city 1 mean 20 km. Thus, the total cost will be 92 km. If the application of the algorithm resulted anywhere in a set of more than two cities and the depot, then it could also be used the TSP/NNR (for example) - which is not the case.

3.4 Conclusion

The aim of combinatorial analysis is the study of combinatorial configurations. The role of this has become more and more important with the ascending complexity and uncertainty of systems and processes in the XXI century. Today's economy requires faster and better operational decisions and tactics; and globalisation, telecommunications and the Internet define new relationships among clients' suppliers, partners and competitors. Lately, its

application has been extended to a variety of other areas like agriculture, finances, marketing and medicine [37], [38].

In this chapter, we focused in the Traveling Salesman Problem and the Clarke and Wright Algorithm as they are the tools expected to be the cases study solvers, although they have different applications for different scenarios (as the Clarke and Wright Algorithm is only to be applied to situations where there are concerns about vehicle capacity) they can also be implemented together to further optimise a routeing problem.

Chapter 4

Case Study

4.1 Introduction

4.2 Airships Characteristics

4.3 Business Model

4.3.1 Cargo

4.3.2 Business Model Canvas

4.3.2.1 Customer Segments

4.3.2.2 Key Resources

4.3.2.3 Key Partners

4.4 Solution Implementation

4.4.1 Introduction

4.4.2 Case 1

4.4.3 Case 2

4.4.4 Case 3

4.4.5 Conclusion

4.5 Business Plan

4.5.1 Cost Structures

4.5.2 Revenue Streams

4.6 Conclusion

4.1 Introduction

Freight transportation has been facing a considerable number of problems this century, like air and sound pollution, road congestion and the deterioration of infrastructures.

The interest in airships has been increasing since they can operate in conditions where other means of transportation would not. Like any other transportation mean airships have advantages and disadvantages. Nevertheless, scientific developments are trying to surpass these inconveniences.

The goal of this case study, which can be divided into three distinct case studies, is the implementation of the previously referred algorithms in a real case scenario of a Portuguese company involving airships too. That is, to compare some transportation costs of the actual logistics solution exclusively based on trucks, and those of new transportation solutions based either on the use of airships solely or join lorries and airships.

4.2 Airship Characteristics

Hybrid Air Vehicles is a privately held British company responsible for manufacturing lighter-than-air technology; this company was born in 2007 acquiring the assets of the Skycat group and established itself in Bedfordshire.

The Airlander 10 is perhaps the most well-known product of Hybrid Air Vehicles. Formerly it was an airship conceived for a military project called Long Endurance Multi-Intelligence Vehicle (LEMV) which was cancelled due to budget issues shortly after its inaugural flight in August 2012. Nonetheless, Hybrid Air Vehicles did not abandon the project but adapted it for a more commercial and practical use [40].

The HAV 304 (also known as Airlander 10) is a hybrid airship which means it achieves lift via both aerostatic and aerodynamic force (Figure 4.1).

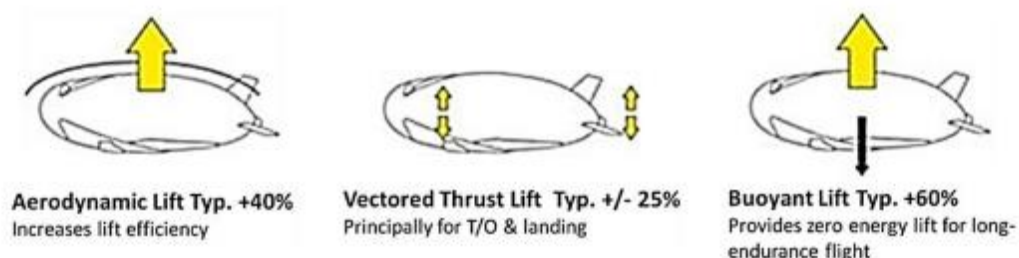

Figure 4. 1 - Scheme representing the lift types in airships.

Source: [41].

Its shape is different from most airships, by discarding the circular cross-section and opting instead for an elliptical shape; this makes it act like a lifting body which contributes for an aerodynamic lift while the airship moves forward.

The helium present provides buoyancy in the envelope, and helium supports most of the airship's weight (between 60 % - 80 %).

Table 4.1 contains the most important specs for the Airlander 10 - which must be used for our case study.

Table 4. 1 - Detailed technical data from Airlander 10.

Source: [42].

Capacity	10.000 kg
Length	92 m
Wingspan	43.5 m
Height	26m
Volume	38.000 m ³
Gross Weight	20.000 kg
Powerplant	4x4 litre V8 turbocharged diesel engines
Cruise Speed	148 km/h
Endurance	5 days if manned 10 days if unmanned
Service Ceiling	6.100 m
Loiter Speed	37 km/h



Figure 4. 2 - Airlander 10 by the British company HAV.

Source: [40].

4.3 Business Model

4.3.1 Cargo

As this study involves an airship for freight transportation, the cargo choice is an important issue.

Mass and balance problems are recurrent in any airborne vehicle. Improper loading negatively compromises the efficiency and performance of the aircraft whether in manoeuvrability, speed, the climb rate and even altitude. Due to abnormal stresses or improper placing of loads in the aircraft, loss of life and destruction of valuable equipment may result [43].

Therefore, the choice of the company with a logistic “problem” was carefully taken into consideration as there was a need for relatively similar and palletizable merchandise.

Our choice was a company located in Portugal market leader in the acquisition, preparation and transportation of coffee beans for the entire Iberian Peninsula; accordingly, since the company wanted to maintain its anonymity, it will be referred as CC (Coffee Company).

4.3.2 Business Model Canvas

Based on Figure 2.1 we filled the information required for Business Model Canvas with a focus on Customers Segments, Key Resources, and Key Partners blocks (Figure 4.3).

4.3.2.1. Customer Segments

This building block establishes the groups of people or organisations that companies aim to reach and serve. In Figure 4.3, the Customer Segment is filled with “companies with homogeneous and palletizable loads” and “companies with specific transportation needs” as these are the target clients this business intends to achieve.

4.3.2.2. Key Resources

This building block states the most crucial assets to make the business model function, this is, the resources for the company to create and offer a Value Proposition and reach markets. They can be characterised as Physical, Human, Intellectual and Financial. In this business model, in particular, the resources are mainly physical and human, and thus both resources are detailed in Figure 4.3. The Physical resources contain vehicles and infrastructures so that airships and hangars were included here. The Human resources include pilots and co-pilots, loadmasters, technicians, maintenance personnel and ground crew.

4.3.2.3. Key Partners

This building block illustrates the partner and suppliers' network necessary to make this business feasible. The Key Partners block shows how relevant it is for a company to form partnerships to improve their business models and reduce risk. Thus, this study must take in consideration airship manufacturers, marketing companies, loading and unloading places, companies with similar and palletizable loads (such as rice, water and coffee).









<p>Key Partners </p> <ul style="list-style-type: none"> -Airship manufacturers; -Marketing companies; -Loading/Unloading places. 	<p>Key Activities </p> <ul style="list-style-type: none"> -Logistics Solution (via airships); -Keep airships airworthy; -Keep loading/unloading places clear to avoid problems with timing. 	<p>Value Proposition </p> <ul style="list-style-type: none"> -Price (low); -High payload; -Straight line transportation; -Advertising along with transportation; -Accessibility and convenience; -Environmentally friendly; -Customizable. 	<p>Customer Relationships </p> <ul style="list-style-type: none"> -Dedicated personnel; -Website; -Television; -Events. 	<p>Customer Segments </p> <ul style="list-style-type: none"> -Companies with homogeneous and palletizable loads; -Companies with specific transportation needs.
<p>Key Resources </p> <ul style="list-style-type: none"> -Physical: Airships and Hangars. -Human: Pilot, Co-Pilot, Load Master, Technician, Maintenance personnel, Ground Crew. 		<p>Channels </p> <ul style="list-style-type: none"> -Awareness; -Commercials; -Website; -Events. 		
<p>Cost Structure </p> <ul style="list-style-type: none"> -Salaries; -Transportation costs (fuel, taxes, etc); -Maintenance -Insurances; -Infrastructures. 			<p>Revenue Streams </p> <ul style="list-style-type: none"> -Advertising revenue; -Services provided. 	

Figure 4. 3 - Business model canvas filled.

Source: own elaboration.

4.4 Solution Implementation

4.4.1 Introduction

For us to study the advantages airships may have in comparison with the already existing cargo transportation solution, the data regarding the CC expenses were collected for specific freight circuits involving specific cities. Besides the headquarter (H) city of CC we also considered other three Portuguese cities to where the company ships coffee - A, B and C.

Tables 4.2 and 4.3 depict the distances (in km) between each pair of cities by road and by a straight line, respectively. This information was collected directly from Google Maps web page.

Table 4. 2 - Road freight distances between each point in km.

Source: own elaboration.

	H	A	B	C
H	0	101	181	261
A		0	82	168
B			0	74
C				0

Table 4. 3 - Distances between each point in a straight line in km.

Source: own elaboration.

	H	A	B	C
H	0	89	129	172
A		0	62	87
B			0	59
C				0

Regarding storage expenses it is known that CC spends monthly in each city:

- A: 2.700,00 €
- B: 2.700,00 €
- C: 2.250,00 €

Figure 4. 4 depicts the actual transportation trips to deliver the shipment required by each city. Figures represent distances (in km), and the repetition of numbers in the same trip means that the return to the headquarters is done using the same route as for shipment.

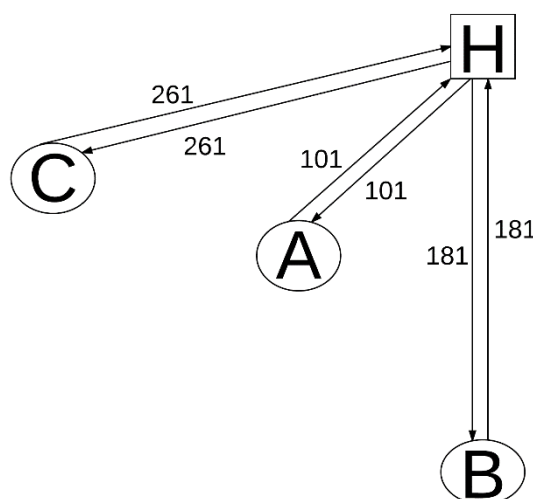

Figure 4. 4 - Current transportation path taken by company's lorries.

Source: own elaboration.

Notice that A and B must be supplied twice a week, and C only must be supplied once. Thus distance made by road, per week, is calculated as follows:

$$D_{RF} = (101 * 2) * 2 + (181 * 2) * 2 + (261 * 2) = 1.650 \text{ km} \quad (13)$$

Let's assume an average of four weeks per month. Thus, the distance travelled monthly will be as follows:

$$D_{RF} = 1.650 * 4 = 6.600 \text{ km} \quad (14)$$

Weekly CC spends 550,00 € to deliver 22.8 tons of coffee to city A, 660,00 € to deliver 22.8 tons of coffee to city B and 330,00 € to deliver 19.8 tons of coffee to city C; moreover, A and B coffee delivery are divided into two weekly shipments.

4.4.2 Case Study 1

In this case, the airship is used five days per week to match the cargo delivered by CC's lorries. It means that the needs of each city will be divided by weekly working days. Daily demand for A, B and C are depicted in Figure 4. 5 (values are simplified for further calculations).

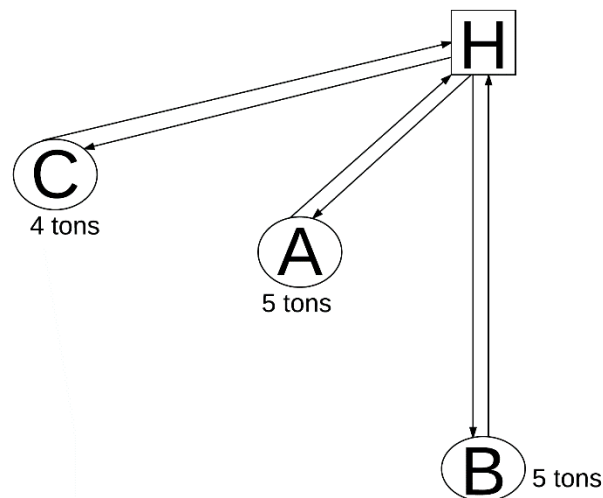

Figure 4. 5 - Approximate results of each city's demand for coffee per day.

Source: own elaboration.

Since in this case, there is a depot, and there is a concern regarding capacities (vehicle and depot-wise) the Clarke and Wright Algorithm was used.

For example, to calculate the savings brought by gathering cities A and B in the same path/circuit of deliveries one must subtract the return distances from each city to the depot and add the distance related with the link between both. That is, instead of 2 circuits, one per each city, resulting in the sum of 2 * 89 km (city A) and 2 * 129 km, then 89 km will be subtracted as well as 129 km which are the straight-line distances from city A to the headquarters/depot

and from city B to the headquarters/depot respectively. Additionally, 62 km are added to connect both cities. Figure 4.6 illustrates this line of thought better.

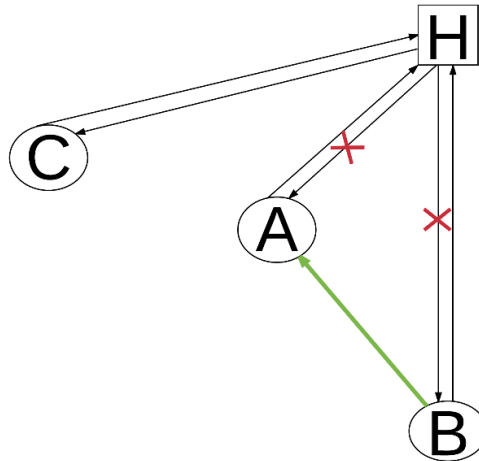

Figure 4. 6- Explanation of how the Clarke and Wright Algorithm works.

Source: own elaboration.

$$S_{AB} = -129 - 89 + 62 = -156 \quad (15)$$

The same method was used to calculate the savings by connecting cities A and C, and cities B and C:

$$S_{BC} = -129 - 172 + 59 = -242 \quad (16)$$

$$S_{AC} = -172 - 89 + 87 = -174 \quad (17)$$

Based on these it is possible to infer that connecting cities B and C would result in saving the biggest amount length-wise and, simultaneously, respecting airship capacity.

The scheme of the final path travelled via airship is depicted in Figure 4. 7.

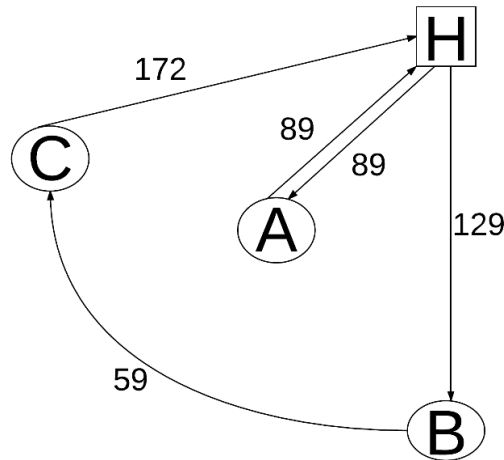

Figure 4. 7 - Representation of the solution for Case Study 1.

Source: own elaboration.

$$Total = 172 + 129 + 59 + 89 * 2 = 538 \text{ km/day} \quad (18)$$

However, city A needs 5 tons of coffee per day, and the airship can carry 10 tons at a time; thus, periodicity can be found to optimise vehicle routes and consequently costs. This way half-empty trips are avoided.

Let's consider an average of four weeks per month. Thus the weekly distance travelled by the airship will be as follows:

$$\text{Week 1: } 538 * 3 + (172 + 129 + 59) * 2 = 2.334 \quad (19)$$

$$\text{Week 2: } 538 * 2 + (172 + 129 + 59) * 3 = 2.156 \quad (20)$$

$$\text{Week 3: } 538 * 3 + (172 + 129 + 59) * 2 = 2.334 \quad (21)$$

$$\text{Week 4: } 538 * 2 + (172 + 129 + 59) * 3 = 2.156 \quad (22)$$

Finally, we can state that the airship will travel 8.980 km per month.

Nevertheless, costs regarding storage in A will remain 2.700 €/month even if the route is optimised to city A. Therefore, we opted to maintain a daily trip to A and so the total distance travelled monthly by the airship will be as follows:

$$D_{C1} = 538 * 5 * 4 = 10.760 \frac{\text{km}}{\text{month}} \quad (23)$$

4.4.3 Case Study 2

In this case, the airship does its freight distribution not only in working days but seven days a week. Therefore, following the methodology as in the previous case study, each city demand was divided by 7 days, that is, the availability of the airship per week:

$$\text{City A: } \frac{22.8}{7} = 3.26 \approx 3.5 \text{ tons} \quad (24)$$

$$\text{City B: } \frac{22.8}{7} = 3.26 \approx 3.5 \text{ tons} \quad (25)$$

$$\text{City C: } \frac{19.8}{7} = 2.83 \approx 3 \text{ tons} \quad (26)$$

In this situation the Clarke and Wright Algorithm was not used as the airship can fulfil the daily demand of each city in just one trip without surpassed its load capacity. Thus, the Travelling Salesman Problem is applied to obtain a feasible solution. The distance between each pair of cities is depicted in Figure 4. 8.

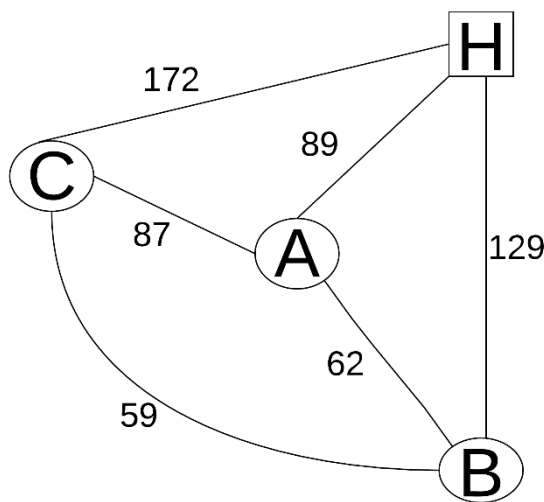

Figure 4. 8 - Distance between each point.

Source: own elaboration.

Since the TSP states that one should start in the depot and check for the “closest neighbour” the airship would leave the company’s headquarters and travel to city A. From city A it should travel to city B (as it is the nearest location) and then to city C. Finally the airship must return to the company’s headquarters, as shown in Figure 4. 9.

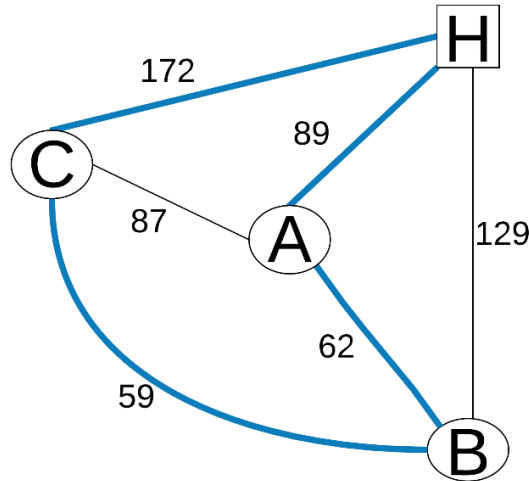

Figure 4. 9 - Scheme of the solution for Case Study 2.
Source: own elaboration

Regarding distance travelled in a straight-line motion, per day, it equals as follows:

$$D = 89 + 62 + 59 + 172 = 328 \text{ km/day} \quad (27)$$

Since the airship must travel every day to be able to match the amount of coffee transported by lorries, the distance travelled by month would be as follows:

$$D_{C2} = 328 * 7 * 4 = 9.184 \text{ km/month} \quad (28)$$

4.4.4 Case Study 3

In this case, coffee freight will be done by combining both lorry and airship in the logistics process. That is, city A would be a depot, and the circuit between H and A would be made as usual by road. The airship would be responsible for the delivery from city A to cities B and C (as depicted in Figure 4. 10).

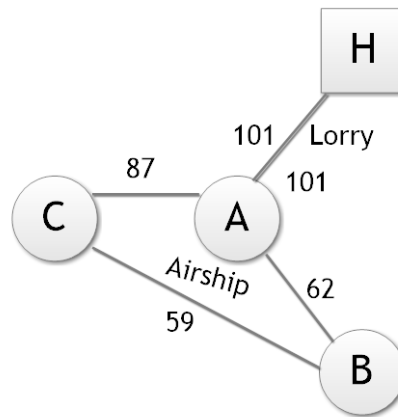

Figure 4. 10 - Explanation of the case study in question.

Source: own elaboration.

Since between H and A there will be no change, the focus is now on the airship path where the TSP will be applied simply to know the direction the airship should take from A to be economically efficient (Figure 4.11).

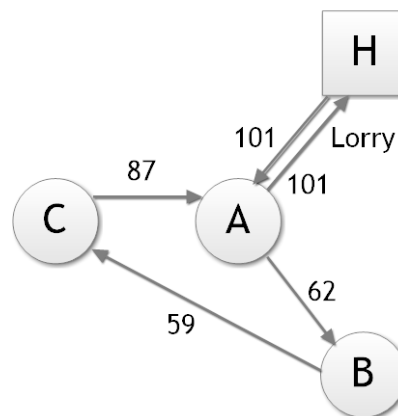

Figure 4. 11 - Scheme of the path where the TSP will be used on.

Source: own elaboration.

Let's remember that in this case study the demand for each city is the weekly one (22.8 tons for both A and B, and 19.8 tons for C) and that all cities start with an empty coffee stock.

The first step is to have a lorry (with 22,8 tons capacity) delivering a full shipment to city A. Therefore city A's demand is fulfilled; so, another shipment from H to A is necessary to deliver coffee to the remaining cities further.

Now there are 45.6 tons of coffee in city A (depot), and since the airship can only transport 10 tons per trip, it has to travel from city A to B and return 3 times. Nonetheless, beforehand the lorry must pick another load from H and deliver it to A (which will result in 68.4 tons in A prior to any other city transportation); only then the airship trip must proceed with 20 tons to be delivered to B. The last 10 tons that enter city B surpass the city's demand for 7.2 tons, so they must be transferred to city C.

Now there are 38.4 tons in city A, 22.8 tons in city B (the shipment is completed) and 7.2 tons in city C. There are still 12.6 tons of coffee missing in city C. This amount needs to be split into two shipments: one of 10 tons and a smaller of just 2.6 tons.

In the end, there are 25.8 tons of coffee in city A, 22.8 tons in city B and 19.8 tons in city C. This implies there are 3 tons of surplus coffee in city A for its weekly needs. Regarding distances, this path equals to 1.410 km per week.

All the following iterations (Table 4.4) result in the same distance travelled (1.410 km). However, the extra tons of coffee available in city A raises 3 tons per iterations, which means that by the end of the 7th iteration (at the end of the 7th week) there will be in city A a surplus of 21 tons. For the 8th iteration, only two lorry trips from city H to A are required; this will result in a journey of 1.208 km and 1.2 tons of extra coffee in city A. It takes 10 months for the stock in A to return to 0 - as the initial value. Then the cycle repeats itself (Table 4.4).

Table 4. 4 - Tons of extra coffee freighted per week.
Source: own elaboration.

	Initial tons	End of week 1	End of week 2	End of week 3	End of week 4	Extra tons
Month 1	0	3	6	9	12	
Month 2	12	15	18	21	24	1,2
Month 3	1,2	4,2	7,2	10,2	13,2	
Month 4	13,2	16,2	19,2	22,2	25,2	2,4
Month 5	2,4	5,4	8,4	11,4	14,4	
Month 6	14,4	17,4	20,4	23,4		0,6
Month 7	0,6	3,6	6,6	9,6	12,6	
Month 8	12,6	15,6	18,6	21,6	24,6	1,8
Month 9	1,8	4,8	7,8	10,8	13,8	
Month 10	13,8	16,8	19,8	22,8		0

Along with that, monthly distances were calculated using the same algorithm as for the first 8 weeks. The results are depicted in Table 4.5.

Table 4. 5 - Distances in kilometres for the first 10 months of Case Study 3.

Source: own elaboration.

Distance (in km)	
Month 1	5.640
Month 2	5.438
Month 3	5.640
Month 4	5.438
Month 5	5.460
Month 6	4.028
Month 7	5.460
Month 8	5.438
Month 9	5.460
Month 10	4.028

4.4.5 Conclusion

The three case studies were developed with the company's interest in mind. They act as a hypothesis that would aid CC to diminish its costs regarding transportation and coffee's storage costs. Case Study 1 is the one with the most kilometres travelled; however, it eliminates storage costs in 3 cities. Case Study 2 does not bring any improvement facing the previous one as there are more transportation costs and coffee storage costs are maintained. Case Study 3 is the hypothesis with the less travelled kilometres, yet it does not allow a reduction in storage costs. So far, the costs per hour travelled are not known, this issue must be analysed later to understand which Case brings the most advantage to the company.

4.5 Business Plan

Like in the aeronautical industry in general, the airship construction and operation sectors are oligopolistic ones which means that only a small group of companies control the entire market and its portrayed. Thus, there are several barriers to the creation of new related companies; the ongoing patent protections processes is just an example.

Figure 4. 12 depicts some intervention areas to keep in mind to determine the feasibility of an airship for logistics, this is to be used for freight transportation purposes as we intend to do with CC. Each of the intervention areas, or key investment areas, have several key investment indicators that should be evaluated carefully. For example, to assess the project costs and revenues, one must analyse at least 9 parameters: Personnel, Insurance, Leasing, Operational, Facilities, Contingency and Miscellaneous (other) Costs; and Operational and Non-operational Revenues.

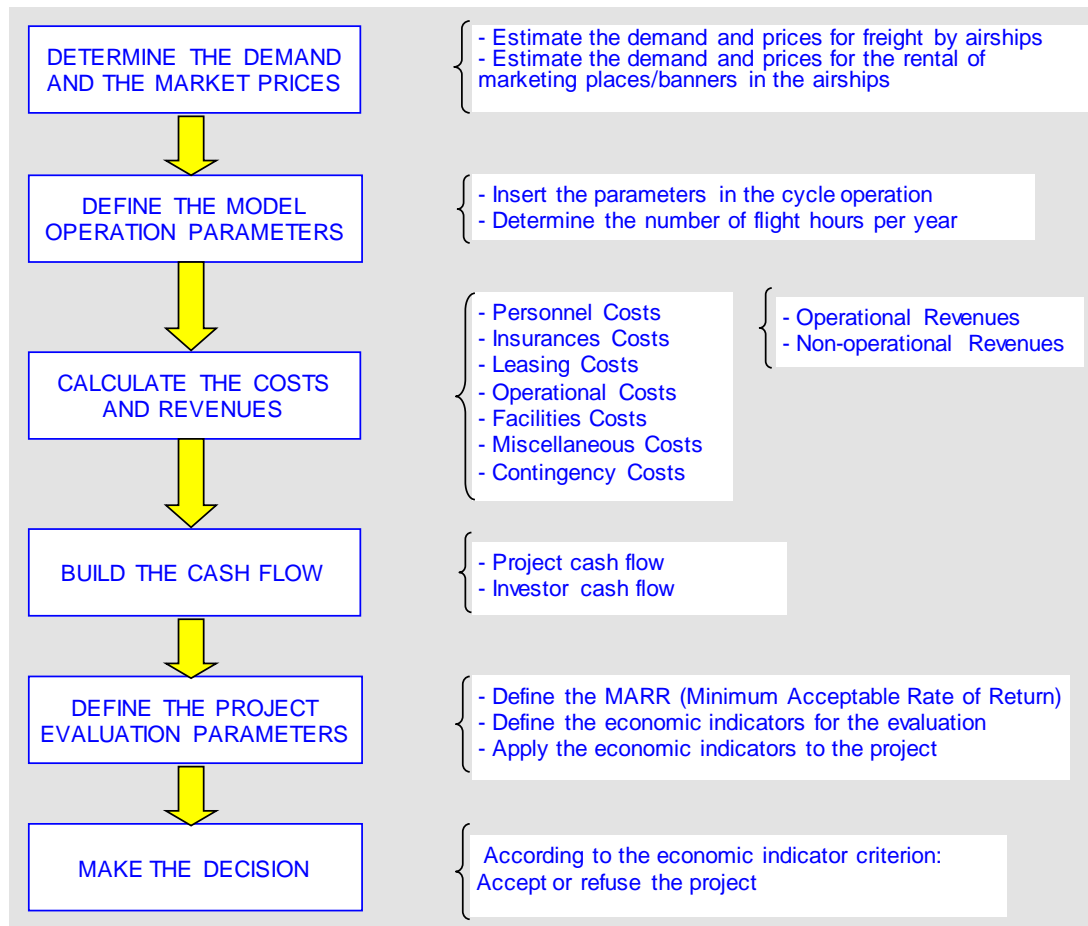

Figure 4. 12 - Economic model representation.

Source: adapted from [29].

Recalling the fact that this thesis proposes a general overview of a business plan for freight logistics using airships, some assumptions had to be made additionally to complete a specific business plan.

For instance, the operational parameters must be evaluated as follows:

- Yearly weeks of operation: this parameter depends on the number of weeks the company can operate, considering that normally 4 out of the 52 weeks of the year are for annual maintenance;
- Weekly days for airship operation: number of days the airship is operated;
- Daily flight: number of available hours per day;
- Operation cycle: number of trips/journeys per flight for one day;
- Weather factor: percentage of total time that the airship is used for flight operations;
- In Europe, it is considered 77%, and in the USA it is 88%;
- Yearly flight hours: number of hours the airship will be used for commercial purposes per year;
- Monthly hours: the international legislation limits the number of work hours for both the aircrew and the ground crew for 100 hours per month and 900 hours per year [29].

Table 4. 6 depicts Cost Structures, and Revenue Streams invoked in 4.5.1 and 4.5.2 respectively. The figures of Table 4. 6 reflect some assumptions made for the Airlander 10 usage within CC logistics process.

Table 4. 6 - Costs and Revenues of using the Airlander 10 as a logistics solution.

Source: adapted from [29].

COSTS		Airship Type	Airlander 10
Personnel		Salarie	Quantity
		Quantity	Cost
	Crew		
	Pilot	70 000,00 €	1
	Co-Pilot	50 000,00 €	1
	Load Master	25 000,00 €	2
	Gorund Crew		
	Manager	45 000,00 €	2
	Technicians	40 000,00 €	2
	Airship marshaller	22 500,00 €	8
Subtotal Personnel		16	520 000,00 €
Insurance	Arishop's value		25 000 000,00 €
	Tax (%)	6,50	
	Written premium		1 625 000,00 €
Leasing	Arishop's value		25 000 000,00 €
	Ground Equipment		75 000,00 €
	Lease %	8,50	
	Period (Years)	7	
	Monthly payments		397 099,87 €
	Yearly payments		4 765 198,47 €
Operational (variable)	Cost per hour		180,00 €
	Yearly flight hours		803
	Total		144 540,00 €
Facilities	Rent		150 000,00 €
	Total		150 000,00 €
Miscellaneous			300 000,00 €
Subtotal			7 504 738,47 €
Contingency (%)	10,00		750 473,85 €
TOTAL COSTS			8 255 212,31 €
REVENUES			
Advertisement	Monthly Rental		600 000,00 €
	Yield		7 200 000,00 €
Freight	Price per hour		180,00 €
	Yearly flight hours		803
	Yield		144 540,00 €
TOTAL REVENUE			7 344 540,00 €
IF THE AIRSHIP IS PAID BY LEASING			
TOTAL COST			8 255 212,31 €
PROFIT OR LOSS			- 910 672,31 €
% Profit over Total Revenue			-12,40
IF THE AIRSHIP IS FINACED BY STAKEHOLDERS			
TOTAL COSTS			3 490 013,85 €
PROFIT OR LOSS			3 854 526,15 €
% Profit over Total Revenue			52,48

4.5.1 Cost Structures

Based on the above-referred specifications of this study some assumptions were made:

- Salaries - salaries paid to pilots by the UK airline ranges from £ 46,000 to £ 52,100; an annual wage of 50,000 € was considered for the main pilot;
- Lease fee percentage - the most common lease fee for aeroplane purchase is 8%; an extra 0.5% was added to keep a more conservative approach;
- Operational - these include expenses related to fuel and oil, air traffic control, etc.; the calculations regarding these costs were made considering Case Study 1 because it is the one with the most kilometres travelled per week;
- Miscellaneous - this section includes crew uniforms, qualification, marketing, office supplies, utilities, etc.; and
- Contingency funds - once again a conservative approach was made hence the 10%.

The cost per flight hour was calculated considering that the Airlander 10 has 20% to 40% of the fuel consumption of a traditional aircraft. The Boeing 777 was used as the reference aircraft to perform such calculations, and the fuel range of this aircraft is 0.12 km/L; within a worst-case scenario, the Airlander has a fuel range of 0.3 km/L. Considering that the Jet fuel price per gallon is approximately 1.29 €, flying our airship would spend 168 € for fuel purposes. To this expense we added maintenance costs which were considered 12 € per hour; thus a total of 180 € per flying hour was obtained.

The flight hours were calculated considering the worst-case scenario which would be the airship travelling the Case Study 1's distance which implies flying 73 hours per month. Considering the 4 weeks per year solely dedicated to maintenance, the airship will only fly 11 months per year, Hence the 803 yearly flight hours.

4.5.2 Revenue Streams

As far as revenues are concerned a monthly rent of 600,000 € is charged to the companies with a particular interest in self-advertising. Regarding freight, the 180,00 € was used as the charged price per flying hours to make the airship as competitive as possible with the actual expense the CC has with lorries with the same transportation purposes.

4.6 Conclusion

This chapter presented the overall case study involving the CC.

Specific considerations are done about airship characteristics, model and business plans too.

The case study was divided into three hypotheses based on three distinct scenarios for CC logistics using either the airship alone or in combination with lorries.

Although the business plan has some made assumptions a conservative approach was taken; therefore the results (Table 4.7) can be considered as close as possible with a real scenario.

Table 4. 7 - Summary of the results delivered by the business plan.
Source: own elaboration.

Revenues			
Advertisement:	7 200 000,00 €		
Freight:	144 540,00 €		
Costs			
Financed by Leasing:	8 255 212,31 €	Loss:	910 672,31 €
Financed by Equity:	3 490 013,85 €	Profit:	3 854 526,15 €

Chapter 5

Result Analysis

5.1 Introduction

5.2 Business Plan

5.2.1 Cost

5.2.2 Revenues

5.2.3 Profits

5.3 Comparison between actual transportation and Airship transportation

5.4 Conclusion

5.1 Introduction

As explained in the methodology section the purpose of the 5th chapter is result analysis, that is, to analyse the results obtained in the previous chapter.

We will begin to analyse the business plan with emphasis on costs, revenues and profits. After that, we will compare CC real road solution with some others using an airship as a logistic aid or as a substitute transportation mean, and thus sustaining the possibility to create a new business model.

5.2 Business Plan

5.2.1 Costs

According to the business plan presented in chapter 4 (Table 4.4), the total yearly costs would ascend to 8.255.212,13 € if the airship is to be paid by leasing (Figure 5.1), and 3.490.013,85 € if the airship is to be paid by stakeholders (Figure 5.2). Remember that the leasing costs represent up to 58% of the total expenses inherent to the business. Based on these figures the best option is to identify the stakeholders interested in funding the project other than the CC company itself.

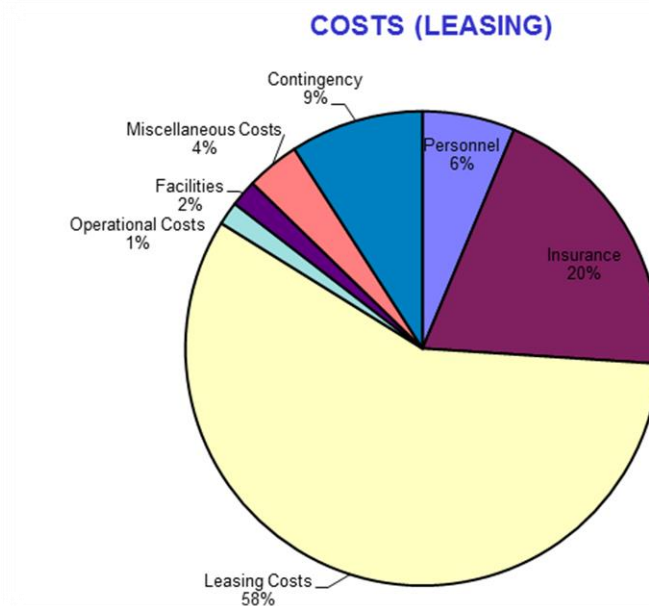

Figure 5. 1 - Representation of the different components and their percentages in the cost structure in a leasing financing case.

Source: adaptation from[29].

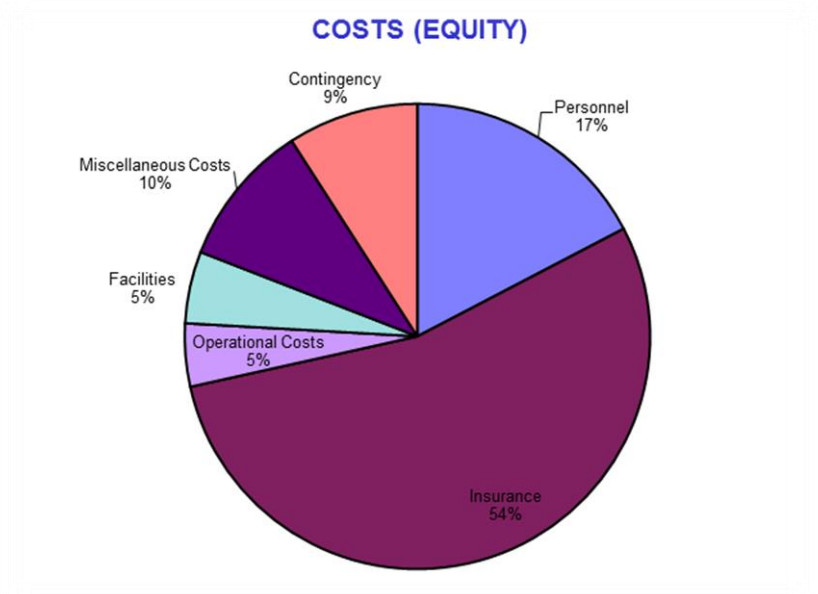

Figure 5. 2 - Representation of the different components and their percentages in the cost structure in an equity financing case.
 Source: adaptation from [29]

5.2.2 Revenues

Through Table 4.4 it is evident that two types of revenues were considered: advertisement and freight. Although the logistic part only represents 1,97% of the revenues, this is still a business that can convey yearly 7.344.540,00 €. Figure 5.3 depicts the proportion of revenues obtained by Freight or Advertisement activities.

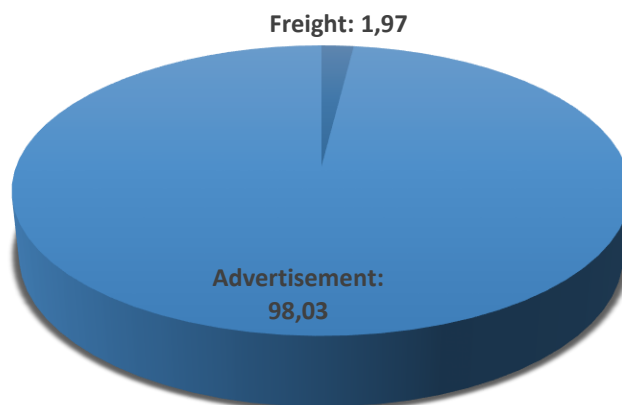

Figure 5. 3 - Graphical representation of the components that add up to the revenues.
 Source: own elaboration.

5.2.3 Profits

As expected the profit in equity financing is higher than the one achieved by leasing. The reason is that it implies a stakeholders investment substantially higher as not only the airship's purchase is made by the operating company but also this company must keep a considerable incoming cash flow to allow the airship's operation - with all the inherent costs - until the profit margin can overcome the direct operating costs.

In the leasing solution, there is no profit - only a loss of 910.672,31 €, which represents a loss of 112.40% of the revenues. However, in the equity case, there is a 3.854.526,15 € profit, reflecting a 52.48% increase when we compare the costs.

5.3 Comparison Between Actual Transportation and Airship Transportation

To prove the feasibility of this project 3 case studies were tested in chapter 4.

In case study 1 the obtained monthly parameters were 10.760 km travelled which would correspond at about 73 flight hours (the airship's cruising speed is 148 km/h). If the hour cost the airship flies equals to 180 €, the monthly cost to use this transportation mean is 13.140 € (as previously stated in this case study there are no expenses regarding storage). The actual road transportation states that, per month, CC spends 13.810 € (including storage and lorry costs). In this particular, the distance travelled were 6.600 km (approximately 66 hours of travel time). Keeping this information in mind, it is clear that by implementing case study 1 solution time travelled would increase 10%, the transportation cost would decrease 4%, and the distance travelled escalates 63%.

In case study 2, the retrieved parameters were 9.184 km travelled in 62 hours, and an overall cost of 11.160€ (once again no storage expenses were included). The airship is flying 10% more time than for the actual road solution, there is a decrease of 20% in the costs, but a rise of 39% regarding kilometres travelled is achieved.

In case study 3, we observed a total of 5.640 km flown in 38 hours with an overall cost of 14.490 € (unlike the previous solutions, now storage costs are must be included). The implementation of this solution would result in a reduction both in flight hours (42%) and kilometres travelled (15%), but an increase of 5% in the costs.

Table 5.1 depicts the overall comparison between the actual CC road solution and our 3 cases of study involving the airship use. Both cases 2 and 3 present two main advantages (green

colour), however since this study aims to reduce costs the best scenario is that of case study 2. Therefore our recommendation is to implement it.

Table 5. 1 - Results from the comparison of each case study to the company’s used road transportation.

Source: own elaboration

	Time (h)	Cost (€)	Distance (km)	Relative time	Relative cost	Relative distance
Road Transportation	66	13.810	6.600			
Case Study 1	73	13.140	10.760	↑ 10%	↓ 4%	↑ 63%
Case Study 2	62	11.160	9.184	↓ 6%	↓ 20%	↑ 39%
Case Study 3	38	14.490	5.640	↓ 42%	↑ 5%	↓ 15%

Based on Table 5.1 we state that case study 2 is the ideal one among all three analysed. Accordingly, a new business plan must be elaborated with updated data, that is, under the premise of 682 yearly flight-hours. As Table 5.2 depicts once again leasing will be not the best solution to incorporate all costs, as still there are losses of 12.41%. On the other hand, when equity financing is applied a 52.67% profit is obtained.

Table 5. 2 - Costs and Revenues of the using the Airlander 10 as a logistics solution with 682 flight-hours per year.

Source: adapted from [29].

COSTS		Airship Type	Airlander 10	
Personnel		Salarie	Quantity	
	Crew		Cost	
		Pilot	70 000,00 €	1
		Co-Pilot	50 000,00 €	1
		Load Master	25 000,00 €	2
	Gorund Crew	Manager	45 000,00 €	2
		Technicians	40 000,00 €	2
		Airship marshaller	22 500,00 €	8
	Subtotal Personnel			16 520 000,00 €
	Insurance	Arishop's value		25 000 000,00 €
Tax (%)		6,50		
Written premium		1 625 000,00 €		
Leasing	Airship's value		25 000 000,00 €	
	Ground Equipment		75 000,00 €	
	Lease %	8,50		
	Period (Years)	7		
	Monthly payments		397 099,87 €	
Yearly payments		4 765 198,47 €		
Operational (variable)	Cost per hour		180,00 €	
	Yearly flight hours		682	
	Total		122 760,00 €	

Facilities	Rent	150 000,00 €	
	Total		150 000,00 €
Miscellaneous			300 000,00 €
Subtotal			7 482 958,47 €
Contingency (%)	10,00		748 295,85 €
TOTAL COSTS			8 231 254,31 €
REVENUES			
Advertisement	Monthly Rental	600 000,00 €	
	Yield		7 200 000,00 €
Freight	Price per hour	180,00 €	
	Yearly flight hours	682	
	Yield		122 760,00 €
TOTAL REVENUE			7 322 760,00 €
IF THE AIRSHIP IS PAID BY LEASING			
TOTAL COST			8 231 254,31 €
PROFIT OR LOSS			- 908 494,31 €
	% Profit over Total Revenue		-12,41
IF THE AIRSHIP IS FINACED BY STAKEHOLDERS			
TOTAL COSTS			3 466 055,85 €
PROFIT OR LOSS			3 856 704,15 €
	% Profit over Total Revenue		52,67

5.4 Conclusion

The economic modulation shows that airship usage for coffee freight distribution may be feasible if the related business plan is based on equity (or stakeholders-based) solution.

The leasing financing is not the most appropriate: the rented airship means a smaller initial investment but direct costs are greater than stakeholders' financing solution. To make leasing funding conceivable, i.e. profitable, the cost per flying hour (paid for the demand) would have to raise from 180 € to 1.222 € which would hardly meet any business requirement or budget.

The scenario, out of the three analysed, able to approximately match the company's (CC) current transportation needs is the case study 2, which implies that the airship is operated 7 days per week roughly 3 hours/day. If any legislation nonconformity arises, for instance, that airship must stop one or two days per week for maintenance, then case study 1 scenario must be considered as the implementable.

Figure 5.1 and Figure 5.2 summarise the withdrawn conclusions from the Case Study comparison.

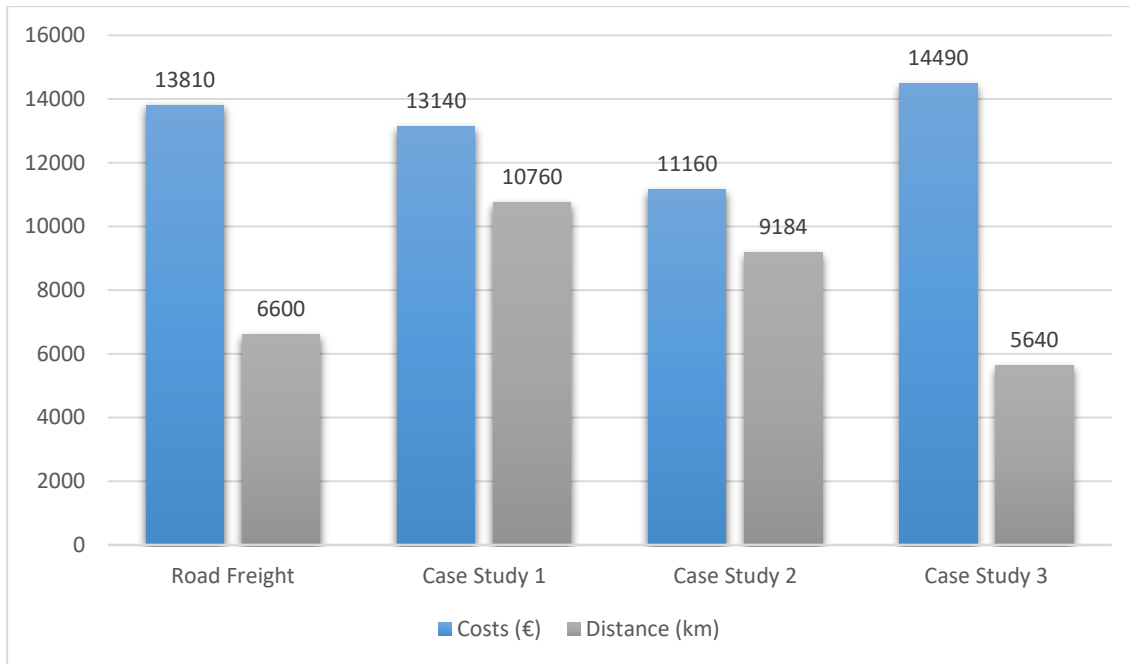

Figure 5. 4 - Summary of the comparison of the data regarding costs and distance travelled.

Source: own elaboration.

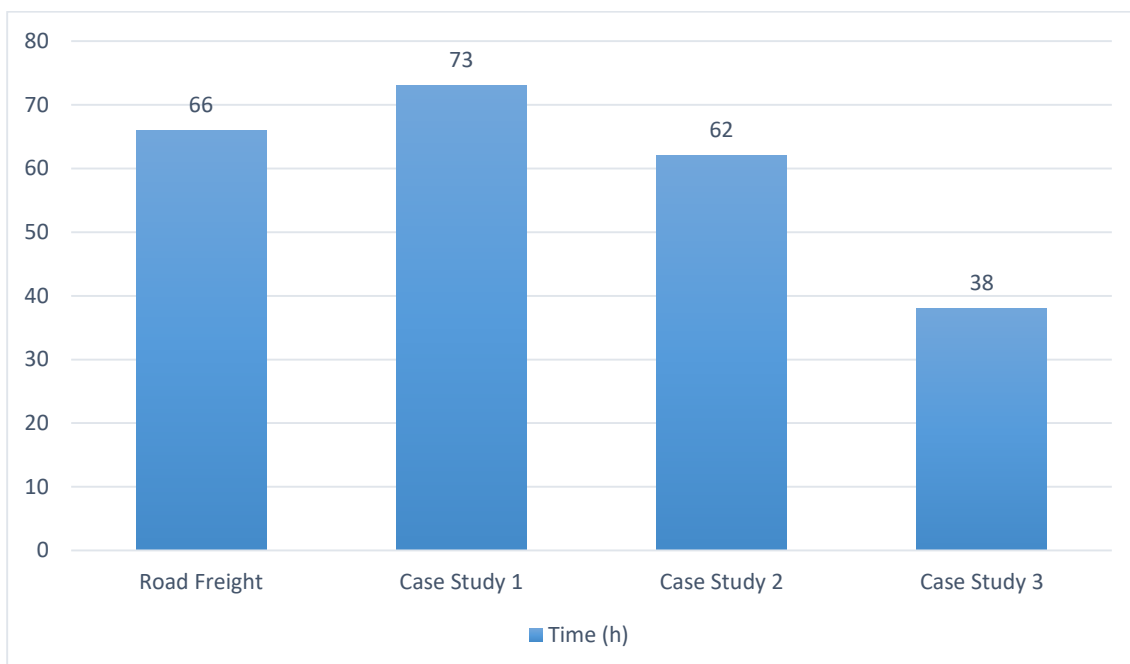

Figure 5. 5 - Summary of the comparison of the data regarding time travelled.

Source: own elaboration.

Chapter 6

Conclusions

6.1 Dissertation Summary

6.2 Concluding Remarks

6.3 Prospects for Future Work

6.1 Dissertation Summary

According to recent studies, the global population is forecasted to grow up to 9.1 billion by 2050, and the urban inhabitants will increase from 50% to 70% of the total world population. That fact will certainly translate into a boost in transportation demand and therefore highlight logistics problems related to infrastructures physical conditions and congestion, oversized freight and air pollution.

The object of this work was an airship for logistics; the objective was to analyse and evaluate the technical and economic viability of a business model for this scenario. There were several sub-objectives to be accomplished to attain that: the airship type assessment, and according to the existing technology if it was adequate to today's freight logistics demands in a market niche. Also, we thought about to evaluate the environmental impact the airship may have when its use was implemented, but this was not possible to achieve mainly due to unavailable data.

Chapter two: A state of the art and literature review was made regarding business modelling, freight logistics, air cargo transportation and airships, to ensure the study had somewhat of a foundation to support decision making when any of the issues mentioned above arise.

Chapter three: we presented and explained the most suitable algorithms for a network optimisation that would be used to sustain the cases of study, mainly: Travelling Salesman Problem (TSP), and the Clarke and Wright Algorithm (CWA). Some examples were presented to explain TSP and CWA.

Chapter four: it was crucial to attaining results that will determine if our proposal could ever be a successful business, both technically and financially, based on several critical parameters:

- the main airships' characteristics and cargo type;
- the business model and plan;
- the contextualization of the case study and optimal solutions to be adopted.

Thus Airlander 10 was explained, the CC was introduced, and the Cases of Study 1, 2 and 3 were detailed.

Chapter five: it derived from the previous one and was focused on the results analysis, mainly: the business plan, and the comparison between road and airship solutions for coffee transportation logistics. Based on updated data, and evaluating pros and cons of leasing or equity financing solutions, we decided the best scenario and business plan to fulfil CC's requirements.

That is, three case studies were selected to investigate the practicability of using the proposed airship to transport cargo from the company's (CC) headquarters to three different Portuguese cities. Thus, calculations were performed for distinct scenarios, or business plans, regarding

several performance indicators (costs, kilometres and hours travelled). The results were then compared to current CC transportation solution.

Last but not the least, promising results were obtained in a way that depicts this is a feasible project (or solution) when funded by equity and if the flight-hour price (or cost) do not exceed 180 €; this will guarantee a 53% profit over the revenues.

6.2 Concluding Remarks

Initially, the airships' concept was to be applied to military assignments, such as weapon transportation and military reconnaissance. The thirties showed that airships could thrive in cargo and people transportation, and even with the Hindenburg disaster, this vehicle's idea was never abandoned but rather postponed until the seventies' oil crisis, which brought enthusiasm once again to this matter.

The beginning of the XXI century, airships had a boom regarding development as there were new materials and technologies to be implemented. With such insights and challenges, new applications became more evident as worldwide airships are being used for border control, tourism and advertisement.

These "giants of the skies" have lots of potential as far as mitigating transportation-related concerns (these include scarcity of fossil fuels, pollution and traffic congestion), as well as to fill the transportation gap of lower value perishables.

According to the advantages of airships when compared to other transportation means, an application of airships to freight was implemented and tested. Surely this work needs more in-depth research, but the feasibility of this concept can be regarded as proven.

The fact that more than one source of revenues was tested turns this thesis closer to the real both operational scenario and business plan. Nevertheless, there is still the need to use a well-prepared approach when reaching the investors and clients to reassure them that, unlike what they may believe, airships are a safe mode of transportation. Only then can there be an airship cargo transportation service strategically implemented and economically feasible.

6.3 Prospects for Future Work

There are still tasks to be done to make this proposal as accurate as possible:

- market demand evaluation;
- service attractiveness evaluation;
- operational and economic sensitivity analysis;
- other revenue sources (for example monitoring and broadcasting).

At last, it is important to note that the current legislation does not include any service like the proposed one. So if any new regulation is enforced some changes may have to be strategically implemented in the strategy mentioned above.

References

- [1] J. Ayre, "EIA: US Gasoline/Petrol Use Hit All-Time High Last Year (2016) | CleanTechnica", [Online]. Available: <https://cleantechnica.com/2017/04/06/eia-us-gasolinepetrol-use-hit-time-high-last-year-2016/>. [Accessed: 04-Sep-2017].
- [2] Boeing Commercial Airplanes, "World Air Cargo Forecast 2016-2017" 2016.
- [3] T. Smith, C. Bingham, P. Stewart, R. Allarton, and J. Stewart, "Energy harvesting and power network architectures for the multibody advanced airship for transport high altitude cruiser-feeder airship concept", *J. Aerosp. Eng.*, vol. 227, no. 4, pp. 586-598, 2013.
- [4] P. H. Coombes and J. D. Nicholson, "Business models and their relationship with marketing: A systematic literature review", *Ind. Mark. Manag.*, vol. 42, no. 5, pp. 656-664, 2013.
- [5] S. M. Shafer, H. J. Smith, and J. C. Linder, "The power of business models", *Bus. Horiz.*, vol. 48, no. 3, pp. 199-207, 2005.
- [6] A. Osterwalder and Y. Pigneur, *Business Model Generation: A Handbook for Visionaries, Game Changers, and Challengers*, John Wiley & Sons. Inc, 2010.
- [7] B. Neto, C. Carvalho, and J. Silva, "Plano de Negócios" in *Curso de Empreendedorismo Online*, 2010, pp. 1-83.
- [8] L. Pinson, *Anatomy of a Business Plan: The Step-by-step Guide to Building Your Business and Securing Your Company's Future*, 2008.
- [9] H. Mukai, S. Dias, F. Feiber, and C. Rodriguez, "Logística urbana", *XXVII Encontro Nac. Eng. Produção*, pp. 1-9, 2007.
- [10] T. G. Crainic, N. Ricciardi, and G. Storchi, "Models for Evaluating and Planning City Logistics Systems", 2009.
- [11] Y. Tseng, "The role of transportation in logistics chain", University of South Australia, 2004.
- [12] "Top Logistics Challenges Facing Shippers Today", 2016. [Online]. Available: <https://www.logisticsplus.net/top-logistics-challenges-facing-shippers-today/>. [Accessed: 30-Jul-2017].
- [13] S. Behrends, "Recent Developments in Urban Logistics Research - A Review of the Proceedings of the International Conference on City Logistics 2009 - 2013", *Transp. Res. Procedia*, vol. 12, no. June 2015, pp. 278-287, 2016.
- [14] Associação da Restauração e Similares de Portugal, *Código de boas práticas para o transporte de alimentos*.
- [15] European Commission, "Regulation (EC) No 172/2002", p. 44, 2002.

- [16] European Commission, "Regulation (EC) No 852/2004", *Off. J. Eur. Communities*, vol. 2002, no. May 2002, pp. 1-54, 2004.
- [17] European Commission, "Engagement of stakeholders when implementing urban freight logistics policies - Technical report", 2016.
- [18] J. Bowen and T. Leinbach, "Market concentration in the air freight forwarding industry", *Tijdschr. voor Econ. en Soc. Geogr.*, vol. 95, no. 2, pp. 174-188, 2004.
- [19] D. J. Donatelli, "Evolution of US Air Cargo Productivity", Massachusetts Institute of Technology, 2012.
- [20] "Texas to India on a Deadline - Global Shipping", [Online]. Available: <https://www.glship.com/case-studies/texas-to-india-on-a-deadline/>. [Accessed: 01-Jun-2017].
- [21] "Shipping Helicopters from Middle East to Alabama - Global Shipping", [Online]. Available: <https://www.glship.com/case-studies/moving-choppers-from-middle-east-to-alabama/>. [Accessed: 01-Jun-2017].
- [22] "Overhead Gantry Cranes - Global Shipping", [Online]. Available: <https://www.glship.com/case-studies/overhead-gantry-cranes/>. [Accessed: 01-Jun-2017].
- [23] "Cargo Air lines - Air Cargo Service - Products", [Online]. Available: <http://www.cal-cargo.com/products>. [Accessed: 04-Jun-2017].
- [24] G. A. Khoury and J. D. Gillett, *Airship Technology*, Cambridge University Press, 1999.
- [25] R. Santos and J. Silva, "Technical and economic feasibility of the use of airships within two portuguese market niches. The tourism and the urban logistic case studies", 2012.
- [26] W. J. White, *Airships for the future*, New York: Stirling Publishing, 1978.
- [27] T. R. Machry, "Dirigíveis: Uma Alternativa Para o Transporte de Cargas Especiais", *Clube Dirigíveis do Bras.*, 2005.
- [28] L. Liao and I. Pasternak, "A review of airship structural research and development", *Prog. Aerosp. Sci.*, vol. 45, no. 4-5, pp. 83-96, 2009.
- [29] L. B. N. Pereira, "Viabilidade Técnica e Económica da Utilização de Dirigíveis no Sector do Turismo em Portugal", Universidade da Beira Interior, 2011.
- [30] B. E. Prentice, S. Chain, F. De Lana, and S. C. Management, "Transport Airships : Not Just Another Aircraft", no. March, pp. 1-15, 2002.
- [31] A. Marques, "Conceptual Design of a Hybrid Airship", Universidade da Beira Interior, 2014.
- [32] P. Bilaye, V. Gawande, U. B. Desai, and R. S. Pant, "Low Cost Wireless Internet

- Access for Rural Areas using Tethered Aerostats”, *Aerospace*, no. 6, pp. 1-6, 2008.
- [33] L. Pereira, J. Silva, C. Gayer, and S. Gomes, “Airships and Conventional Air Transportation Systems . The Case of the Portuguese Tourism Sector”, *ICEUBI2011 Int. Conf. Eng.*, 2011.
- [34] S. Relekar and R. S. Pant, “Airships As A Low Cost Alternative To Communication Satellites”, *Natl. Conf. LTA Technol.*, pp. 1-17, 2002.
- [35] “CargoLifter Applications”, [Online]. Available: <https://www.cargolifter.com/applications/>. [Accessed: 30-Apr-2017].
- [36] E. Lawler, *Combinatorial Optimization: Networks and Matroids*, 1976.
- [37] M. Arenales, V. Armentano, R. Morabito, and H. Yanasse, *Pesquisa Operacional*, Rio de Janeiro: Elsevier Ltd, 2007.
- [38] M. M. Hill, M. M. dos Santos, and A. L. Monteiro, *Transportes, afetação e otimização de redes*, 1st ed. Lisboa: Edições Sílabo, 2008.
- [39] L. Caccetta and S. P. Hill, “Branch and cut methods for network optimization”, *Math. Comput. Model.*, vol. 33, no. 4-5, pp. 517-532, 2001.
- [40] “Hybrid Air Vehicles - Airlander 10”, [Online]. Available: <https://www.hybridairvehicles.com/aircraft/airlander-10>. [Accessed: 25-Aug-2017].
- [41] T. Amaral, “Conceptual Design of the Gondola of a Hybrid Airship Including Loading and Unloading Mechanisms”, 2015.
- [42] Hybrid Air Vehicles, “Airlander 10 Technical Data”, no. August, 2016.
- [43] Federal Aviation Administration, “Weight and Balance Handbook (FAA-H-8083-1B)”, 2016.

Annex 1

Publications' Abstracts



DESEMPENHO OPERACIONAL (VIABILIDADE) DE DIRIGÍVEIS PARA UM MODELO E PLANO DE NEGÓCIOS EM LOGÍSTICA URBANA E NÃO-URBANA

AIRSHIPS OPERATIONAL PERFORMANCE (FEASIBILITY) FOR AN URBAN AND NON-URBAN LOGISTICS BUSINESS MODEL AND PLAN

Inês Cruz¹, Maria E. Baltazar², Jorge Silva³

¹ Universidade da Beira Interior, Aerospace Sciences Department (DCA-UBI) Covilhã, Portugal
CERIS CESUR, Instituto Superior Técnico, Universidade de Lisboa, Lisboa, Portugal
inesramoscruz.rc@gmail.com

² Universidade da Beira Interior, Aerospace Sciences Department (DCA-UBI) Covilhã, Portugal
CERIS CESUR, Instituto Superior Técnico, Universidade de Lisboa, Lisboa, Portugal
mmila@ubi.pt

³ Universidade da Beira Interior, Aerospace Sciences Department (DCA-UBI) Covilhã, Portugal
CERIS CESUR, Instituto Superior Técnico, Universidade de Lisboa, Lisboa, Portugal
jmrs@ubi.pt

ABSTRACT

This paper and its research were developed to analyse the performance potential, network optimisation and list the cost structure, thus identifying and quantifying the costs' structure associated with the implementation of an airship as an urban logistics transportation. Several concepts were taken into consideration such as the actual airships' technology, authors' business model and business plan approach in urban logistics and air cargo transportation. A network optimisation algorithm was developed within operational research methodology. The results depict the airships' items and components needed to propose a business model and afterwards a business plan to elaborate an urban logistics' solution suitable to the retailers' interest. The case study focused on coffee retailing in an urban and non-urban scenario in Portugal. Airships have advantages when it comes to multifunctionality and, being the flow of goods increasing; they are an alternative solution to address traffic congestion and poor street conditions than usual

road freight transport systems. Environmental concerns are one of the several reasons that make airships a greener air vehicle following the environmental-friendly trends in the sector. This paper describes the technological challenges to implementing airship operations in market niches like the retailing market segment and proposes a solution to a new type of urban logistics freight.

Keywords: *Airships, Business Plan, Network Optimisation, Operational Performance, Urban Logistics.*



Airships in Freight Logistics

Inês Cruz^{1, 2, *}, Maria E. Baltazar^{1, 2}, Jorge Silva^{1, 2}

¹Universidade da Beira Interior, Aerospace Science Department (DCA-UBI), Rua Marquês d'Ávila e Bolama, 6201- 001, Covilhã, Portugal.

²CERIS, CESUR, Instituto Superior Técnico, Universidade de Lisboa, Av. Rovisco Pais 1, 1049-001, Lisboa, Portugal

*Corresponding author: inesramoscruz.rc@gmail.com

Co-authors email: mmila@ubi.pt; jmiguel@ubi.pt

Abstract:

The beginning of the XXI century, airships had a boom in terms of development as there were new materials and technologies to be implemented. With this, new applications became more evident as worldwide airships are being used for border control, tourism and advertisement.

These “giants of the skies” have a great deal of potential when applied to mitigate transportation-related concerns (these include scarcity of fossil fuels, pollution and traffic congestions), as well as fill the transportation gap of lower value perishables.

In this paper, according to the advantages of airships when compared to the other transportation methods, an application of airships to freight logistics was considered and tested. Concepts like business models and plans, network optimization algorithms, logistics and airships technology revealed themselves to be crucial in understanding the problematic around this subject and how to overcome it.

The case study was based on a company’s need for decreasing the costs associated to shipping its product. Three possible scenarios were proposed, analysed and a comparison was made between each one of them and the current transportation mode the company has.

Promising results were obtained as a reduction in 20 % in price was observed, relatively to the road freight, when using an airship as a transportation device which shows that it is possible to implement this solution and still profit from it.

Keywords:

Airships; Business Plan; Business Model; Logistics; Network Optimization.