

# Prefilter Bandwidth Effects in Asynchronous Sequential Symbol Synchronizers based on Pulse Comparison by Hybrid Transitions at Quarter Bit Rate

Antonio D. Reis, Jose F. Rocha, Atilio S. Gameiro and Jose P. Carvalho

**Abstract - This** This work studies the prefilter bandwidth effects in four asynchronous sequential symbol synchronizers. We consider three prefilter bandwidths namely  $B1=\infty$ ,  $B2=2.tx$  and  $B3=1.tx$ , where  $tx$  is the bit rate. The synchronizer has two variants one asynchronous by both transitions at bit rate and other asynchronous by hybrid (both and positive) transitions at quarter bit rate. Each variant has two versions namely the manual and the automatic. The objective is to study the prefilter with the four synchronizers and to evaluate their output jitter UIRMS (Unit Interval Root Mean Square) versus input SNR (Signal Noise Ratio).

**Index Terms**—Prefilter, Digital Communication Systems

## I. INTRODUCTION

This work studies the prefilter bandwidth effects on the jitter-SNR behavior of four sequential symbol synchronizers.

The prefilter, applied before the synchronizer, switches their bandwidth between three values namely first  $B1=\infty$ , after  $B2=2.tx$  and next  $B3=1.tx$ , where  $tx$  is the bit rate [1,2].

The synchronizer has four versions supported in two variants, one asynchronous by both transitions at bit rate with versions manual (ab-m) and automatic (ab-a) and other asynchronous by hybrid transitions at quarter bit rate with versions manual (ab-m/4) and automatic (ah-a/4) [3, 4, 5, 6].

The difference between the four synchronizers is in the phase comparator. The clock is the VCO (Voltage Controlled Oscillator) that samples appropriately and retimes correctly the input data, guarantying good quality [7, 8, 9, 10, 11, 12].

Fig.1 shows the prefilter followed of the synchronizer.

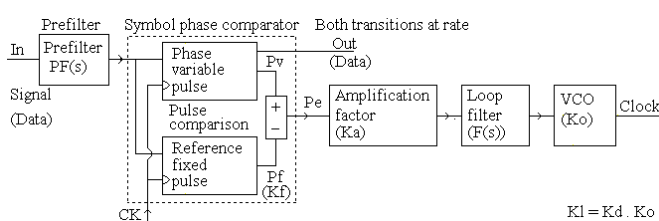

Fig.1 Prefilter with the sequential symbol phase synchronizer

Manuscript received March 10, 2017; Supports from UBI (University of Beira Interior) and FCT (Foundation for sCience and Technology).

A. D. Reis is with the University of Beira Interior Covilha and Goup of A. P. and Telecommunications, Portugal (e-mail: adreis@ ubi.pt).

J. F. Rocha is with the University of Aveiro and Institute of Telecommunications, Portugal (e-mail: frocha@ ua.pt).

A. S. Gameiro is with the University of Aveiro and Institute of Telecommunications, Portugal (e-mail: amg@ ua.pt).

J. P. Carvalho is with the University of Beira Interior Covilha and Group of A. P. and Telecom., Portugal (e-mail: pacheco@ ubi.pt).

PF(s) is the prefilter (low pass). The synchronizer has various blocks, namely Kf is the phase detector gain, F(s) is the loop filter, Ko is the VCO gain and Ka is the loop gain factor that controls the root locus and loop characteristics.

In priori and actual-art state was developed various synchronizers, but is necessary to know their performance.

The motivation of this work is to create new synchronizers and to see the prefilter effects. This contribution improves the know-how about synchronizers performance.

Following, we present the prefilter with their three different decreasing bandwidths ( $B1=\infty$ ,  $B2=2.tx$ ,  $B3=1.tx$ ).

After, we present the standard reference variant, asynchronous sequential symbol synchronizers based on pulse comparison by both transitions at bit rate, with versions manual (ab-m) and automatic (ab-a). Next, we present the new proposed variant, asynchronous sequential symbol synchronizers based on pulse comparison by hybrid transitions at quarter bit rate, with versions manual (ab-m/4) and automatic (ah-a/4). After, we present the design and tests. Then, we present the results. Finally, we present the conclusions.

## II. PREFILTER BANDWIDTH EFFECTS

We apply a prefilter before the synchronizer, we switches its bandwidth B between three values ( $B1=\infty$ ,  $B2=2.tx$ ,  $B3=1.tx$ ), then we study the effects on the four jitter-SNR curves. Fig.2 shows the three prefilter bandwidths.

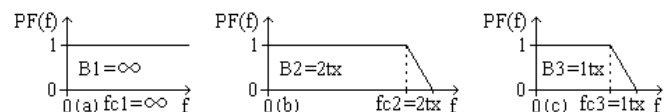

Fig.2 Three prefilter bandwidths: a)  $B1=\infty$ ; b)  $B2=2.tx$ ; c)  $B3=1.tx$

Following, we describe the prefilter with its three bandwidths ( $B1=\infty$ ,  $B2=2.tx$ ,  $B3=1.tx$ ).

### A. Prefilter with Bandwidth equal infinite ( $B1=\infty$ )

This prefilter (Fig.2a) has a bandwidth equal infinite ( $B=\infty$ ). We will see its effects on the four synchronizers.

### B. Prefilter with Bandwidth equal two tx ( $B2=2.tx$ )

This prefilter (Fig.2b) has a bandwidth equal two times the bit rate ( $B=2.tx$ ). We will see its effects on the four synchronizers.

### C. Prefilter with Bandwidth equal one tx ( $B3=1.tx$ )

This prefilter (Fig.2c) has a bandwidth equal one time the bit rate ( $B=1.tx$ ). We will see its effects on the four synchronizers.

### III. REFERENCE BY BOTH AT BIT RATE

The standard reference, asynchronous sequential symbol synchronizers based on pulse comparison operating by both transitions at bit rate has two versions which are the manual (ab-m) and the automatic (ab-a) [1, 2]. The versions difference is in the phase comparator, the variable pulse Pv is common but the fixed Pf is different. Their jitter - SNR curves are the reference quality.

#### A. Reference by both at rate manual (ab-m)

The block Pv, shown below, produces a variable pulse Pv between the input bits and VCO. The manual adjustment delay with Exor produces a manual fixed pulse Pf (Fig.3).

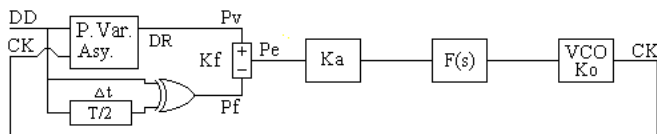

Fig.3 Asynchronous by both at rate and manual (ab-m)

The comparison between the pulses Pv and Pf provides the error pulse Pe that forces the VCO to synchronize the input. The block Pv is an asynchronous circuit (Fig.4).

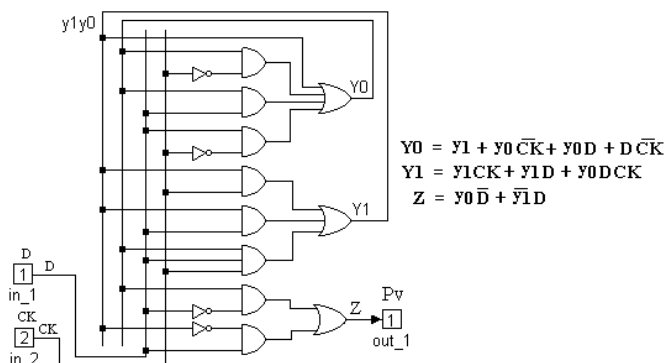

Fig.4 Intern aspect of the block Pv

The error pulse Pe diminishes during the synchronization time and disappear at the equilibrium point.

#### B. Reference by both at rate automatic (ab-a)

The block Pv, common with previous, produces the variable pulse Pv between input and VCO. The block Pf, shown below, produces the comparison fixed pulse Pf (Fig.5).

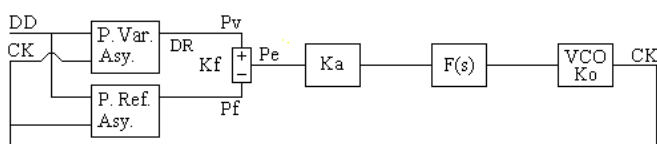

Fig.5 Asynchronous by both at rate and automatic (ab-a)

The comparison between the pulses Pv and Pf provides the error pulse Pe that forces the VCO to follow the input. The block Pf is an asynchronous circuit (Fig.6).

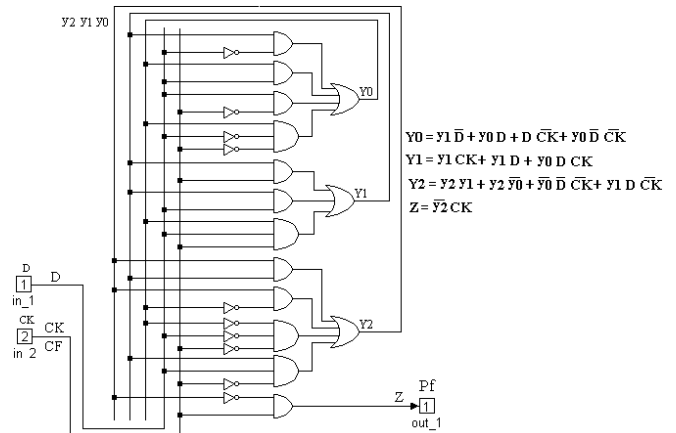

Fig.6 Intern aspect of the block Pf

The error pulse Pe don't disappear, but the variable area Pv is equal to the fixed Pf at the equilibrium point.

### IV. PROPOSAL BY HYBRID AT QUARTER BIT RATE

The new proposal, asynchronous sequential symbol synchronizers based on pulse comparison operating by hybrid transitions at quarter bit rate has also two versions namely the manual (ab-m/4) and the automatic (ah-a/4)[3, 4].

The versions difference is in the phase comparator, the variable pulse Pv is common but the fixed Pf is different. Their jitter - SNR curves are compared with the previous.

#### A. Proposal by both at quarter manual (ab-m/4)

The block Pv produces the variable pulse Pv between input transitions and VCO. The manual adjustment delay T/2 with Exor produces a fixed pulse Pf (Fig.7).

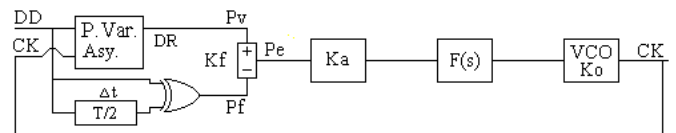

Fig.7 Asynchronous by both at quarter rate and manual (ab-m/4)

The comparison between pulses Pv and Pf provides the error pulse Pe that forces the VCO to synchronize the input. The block Pv is an asynchronous circuit (Fig.8).

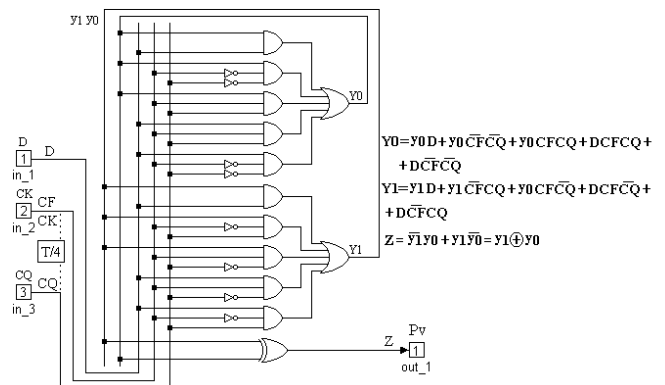

Fig.8 Intern aspect of the block Pv

The error pulse Pe diminishes during the synchronization time and disappear at the equilibrium point.

**B. Proposal by hybrid at quarter automatic (ah-a/4)**

The block Pv, common, produces the variable pulse Pv between input and VCO. The block Pf, shown below, produces the comparison fixed pulse Pf (Fig.9).

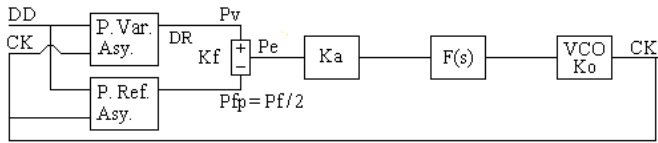

Fig.9 Asynchronous by hybrid at quarter and automatic (ah-a/4)

The comparison between the pulses Pv and Pf provides the error pulse Pe that forces the VCO to follow the input. The block Pfp, that uses only the positive transitions, is an asynchronous circuit (Fig.10).

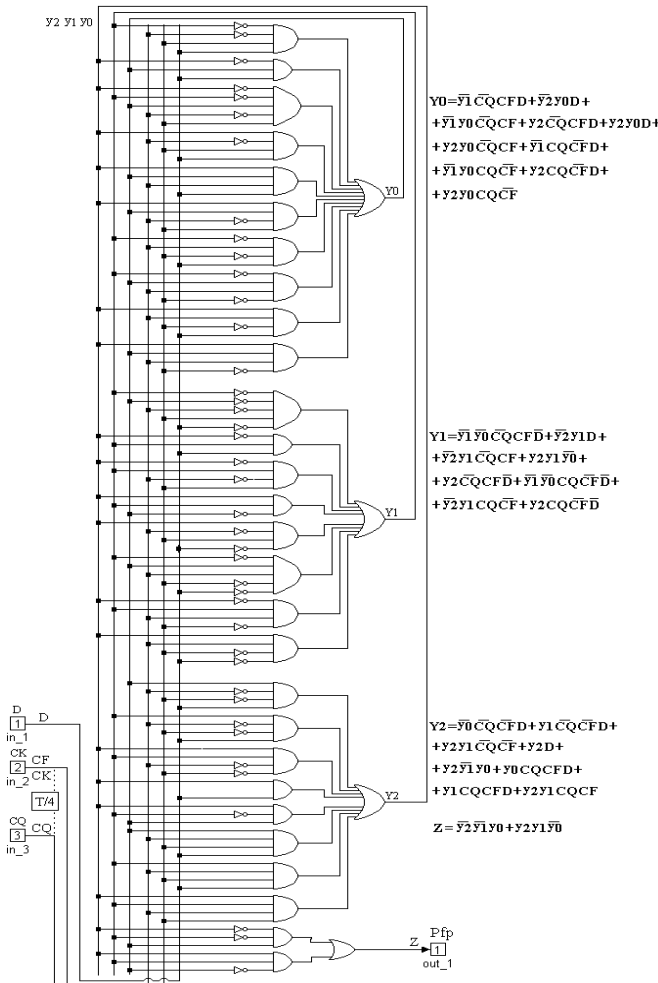

Fig.10 Intern aspect of the block Pfp (without 0.5)

The error pulse Pe don't disappear at the equilibrium point, but the variable area Pv becomes equal to the fixed Pf.

**IV. DESIGN, TESTS AND RESULTS**

We show the design, tests and results of the various synchronizers [5].

**A. Design**

We design all the synchronizers with the same loop gain conditions, to get reliable results. The loop gain is  $Kl = KdKo = KaKfKo$ , where Kf and Ko are fixed and Ka is the loop gain, that controls the roots and the loop characteristics.

To simplify the analysis, we use normalized values for the bit rate  $tx=1$  baud, clock frequency  $fck=1$  Hz, extern noise bandwidth  $Bn= 5$  Hz and loop noise bandwidth  $B1= 0.02$  Hz.

We use a signal power  $Ps= A_{ef}^2$  with noise power  $Pn= No.Bn= 2\sigma_n^2.\Delta\tau.Bn$ , where  $\sigma_n$  is the noise standard deviation and  $\Delta\tau = 1/fSamp$  is the sampling period. The relation between SNR and noise variance  $\sigma_n^2$  is  $SNR= Ps/Pn= A_{ef}^2/(No.Bn)= 0.5^2/(2\sigma_n^2*10^{-3}*5)= 25/\sigma_n^2$  (1) So, for each synchronizer, we must measure the output jitter UIRMS versus the input SNR

- 1<sup>st</sup> order loop:

Taking a cutoff loop filter  $F(s)=0.5$  Hz, which is 25 times greater than  $B1= 0.02$  Hz, eliminates the high frequencies but maintains the loop characteristics. The transfer function is

$$H(s) = \frac{G(s)}{1+G(s)} = \frac{KdKoF(s)}{s + KdKoF(s)} = \frac{KdKo}{s + KdKo} \quad (2)$$

the loop noise bandwidth is

$$B1 = \frac{KdKo}{4} = Ka \frac{KfKo}{4} = 0.02 \text{ Hz} \quad (3)$$

So, with  $(Km=1, A=1/2, B=1/2, Ko=2\pi)$  and loop bandwidth  $B1=0.02$ , we obtain the Ka, for the synchronizers:

analog:  $B1=0.02 = (Ka.Km.A.B.Ko)/4 \rightarrow Ka=0.08*2/\pi$  (4)

hybrid:  $B1=0.02 = (Ka.Km.A.B.Ko)/4 \rightarrow Ka=0.08*2.2/\pi$  (5)

combinational:  $B1=0.02 = (Ka*1/\pi*2\pi)/4 \rightarrow Ka=0.04$  (6)

sequential:  $B1=0.02 = (Ka*1/2\pi*2\pi)/4 \rightarrow Ka=0.08$  (7)

For the analog PLL, the jitter is

$$\sigma_\phi^2 = B1.No/A_{ef}^2 = 0.02*10^{-3}*2\sigma_n^2/0.5^2 = 16*10^{-5}.\sigma_n^2 \quad (8)$$

For the others PLLs, the jitter formula is more complicated.

- 2<sup>nd</sup> order loop:

It is not used here, but it gives similar results.

**B. Tests**

We used the following setup to test synchronizers (Fig.11)

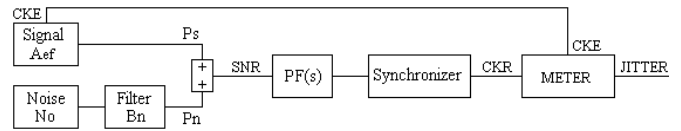

Fig.11 Block diagram of the test setup

The receiver recovered clock with jitter is compared with the emitter original clock, then the difference is the jitter.

**C. Results**

We will present the results, in terms of jitter - SNR, for each prefilter bandwidth with the four synchronizers.

Fig.12 shows the jitter-SNR curves for the prefilter bandwidth  $B1=\infty$  with the four synchronizers (ab-m, ab-a, ab-m/4, ah-a/4).

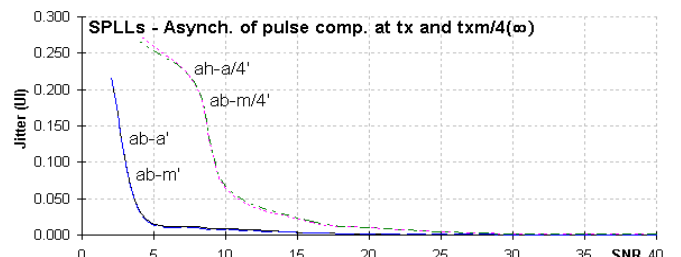

Fig.12 Jitter-SNR curves of B1+4 synchro. (ab-m,ab-a,ab-m/4,ah-a/4)

For prefilter  $B_1=\infty$ , we verify that, for high SNR, the four synchronizer jitter-SNR curves tend to be similar. However, for low SNR, the variant asynchronous by both at rate with versions manual (ab-m) and automatic (ab-a) are better than the variant asynchronous by hybrid at quarter rate with versions manual (ab-m/4) and automatic (ah-a/4).

Fig.13 shows the jitter-SNR curves for the prefilter bandwidth  $B_2=2.tx$  with the four synchronizers (ab-m, ab-a, ab-m/4, ah-a/4).

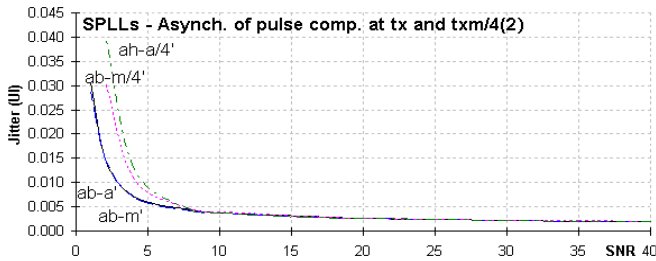

Fig.13 Jitter-SNR curves of  $B_2+4$  synchro. (ab-m,ab-a,ab-m/4,ah-a/4)

For prefilter  $B_2=2.tx$ , we verify that, it becomes the jitter-SNR curves more similar between themselves. For high SNR, it degrades slightly the jitter-SNR curves. However, for low SNR it benefits significantly the jitter - SNR curves.

Fig.14 shows the jitter-SNR curves for the prefilter bandwidth  $B_3=1.tx$  with the four synchronizers (ab-m, ab-a, ab-m/4, ah-a/4).

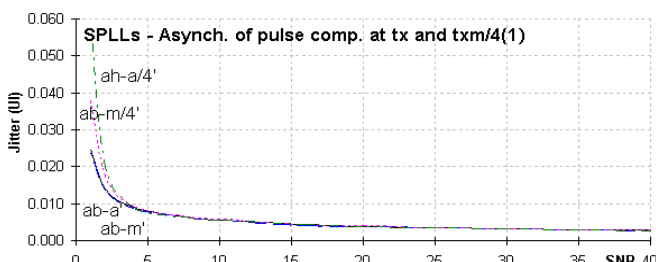

Fig.14 Jitter-SNR curves of  $B_3+4$  synchro. (ab-m,ab-a,ab-m/4,ah-a/4)

For prefilter  $B_3=1.tx$ , we verify that, it becomes the jitter-SNR curves still more similar between themselves. For high SNR, it degrades more the jitter-SNR curves. However, for low SNR, it benefits less the jitter-SNR curves.

## V. CONCLUSIONS

We studied three prefilter bandwidths ( $B_1=\infty$ ,  $B_2=2.tx$ ,  $B_3=1.tx$ ) with four synchronizers, one variant asynchronous by both transitions at rate with versions manual (ab-m) and automatic (ab-a) and other variant asynchronous by hybrid at quarter rate with versions manual (ab-m/4) and automatic (ah-a/4). Then, we measured their jitter - SNR curves.

We observed that, in general, the output jitter curves decreases gradually with the input SNR increasing.

For prefilter  $B_1=\infty$  (greater), we verified that, for high SNR, the four synchronizers jitter curves tend to be similar, this is comprehensible since all the synchronizers are digital and have similar noise margin. However, for low SNR, the variant asynchronous by both at rate with its versions manual (ab-m) and automatic (ab-a) is better than the variant asynchronous by hybrid at quarter rate with its versions manual (ab-m/4) and automatic (ah-a/4), this is comprehensible since the variant by both transitions at bit rate has minus states than the variant by hybrid at quarter rate and then, the time to pass from the error state to the correct state is lesser in the 1st case.

For prefilter  $B_2=2.tx$  (medium), we verified that, it becomes the jitter-SNR curves more similar between themselves. For high SNR, it degrades slightly the jitter-SNR curves. However, for low SNR, it benefits significantly the jitter-SNR curves.

For prefilter  $B_3=1.tx$  (lesser), we verify that, it becomes the jitter-SNR curves still more similar between themselves. For high SNR, it degrades more the jitter-SNR curves. Also, for low SNR, it benefits less the jitter-SNR curves.

So, the prefilter, for high SNR, distorts the signal what is prejudicial, for low SNR, attenuates noise what is beneficial.

In the future, we are planning to extend the present study to other types of synchronizers.

## ACKNOWLEDGMENTS

The authors are grateful to the program FCT (Foundation for sScience and Technology).

## REFERENCES

- [1] J. C. Imbeaux, "performance of the delay-line multiplier circuit for clock and carrier synchronization", IEEE Jou. on Selected Areas in Communications p.82 Jan. 1983.
- [2] Werner Rosenkranz, "Phase Locked Loops with limiter phase detectors in the presence of noise", IEEE Trans. on Communications com-30 N°10 pp.2297-2304. Oct 1982.
- [3] H. H. Witte, "A Simple Clock Extraction Circuit Using a Self Sustaining Monostable Multivibrat. Output Signal", Electronics Letters, Vol.19, Is.21, pp.897-898, Oct 1983.
- [4] Charles R. Hogge, "A Self Correcting Clock Recovery Circuit", IEEE Tran. Electron Devices p.2704 Dec 1985.
- [5] A. D. Reis, J. F. Rocha, A. S. Gameiro, J. P. Carvalho "A New Technique to Measure the Jitter", Proc. III Conf. on Telecommunications pp.64-67 FFoz-PT 23-24 Apr 2001.
- [6] Marvin K. Simon, William C. Lindsey, "Tracking Performance of Symbol Synchronizers for Manchester Coded Data", IEEE Transactions on Communications Vol. com-2.5 N°4, pp.393-408, April 1977.
- [7] J. Carruthers, D. Falconer, H. Sandler, L. Strawczynski, "Bit Synchronization in the Presence of Co-Channel Interference", Proc. Conf. on Electrical and Computer Engineering pp.4.1.1-4.1.7, Ottawa-CA 3-6 Sep. 1990.
- [8] Johannes Huber, W. Liu "Data-Aided Synchronization of Coherent CPM-Receiver" IEEE Transactions on Communications Vol.40 N°1, pp.178-189, Jan. 1992.
- [9] Antonio D'Amico, A. D'Andrea, Reggianni, "Efficient Non-Data-Aided Carrier and Clock Recovery for Satellite DVB at Very Low SNR", IEEE Jou. on Sattelite Areas in Comm. Vol.19 N°12 pp.2320-2330, Dec. 2001.
- [10] Rostislav Dobkin, Ran Ginosar, Christos P. Sotiriou "Data Synchronization Issues in GALS SoCs", Proc. 10th International Symposium on Asynchronous Circuits and Systems, pp.CD-Ed., Crete-Greece 19-23 Apr. 2004.
- [11] A. D. Reis, J. F. Rocha, A. S. Gameiro, J. P. Carvalho "Optical Digital Communication Systems and Synchronism", Proc. 7th UBI International Conference on Engeneering (for E. D.)-ICEUBI 2013, pp.CT8-11.7, Covilhã-PT 27-29 Nov. 2013.
- [12] A. D. Reis, J. F. Rocha, A. S. Gameiro, J. P. Carvalho, "Prefilter Bandwidth Effects in Asynchronous Sequential Symbol Synchronizers based on Pulse Comparison by Positive Transitions at Quarter Bit Rate", Proc. World Congress on Engineering 2016, 'WCE 2016', pp.383-386, London-UK, 29 June - 1 July 2016.