

Wilfrid Laurier University

Scholars Commons @ Laurier

Theses and Dissertations (Comprehensive)

2016

Investigating balance-enhancing effects of midsole hardness and thickness for older adult footwear

Elizabeth McLeod

Wilfrid Laurier University, liz_biz_290@hotmail.com

Follow this and additional works at: <https://scholars.wlu.ca/etd>

Recommended Citation

McLeod, Elizabeth, "Investigating balance-enhancing effects of midsole hardness and thickness for older adult footwear" (2016). *Theses and Dissertations (Comprehensive)*. 1893.

<https://scholars.wlu.ca/etd/1893>

This Thesis is brought to you for free and open access by Scholars Commons @ Laurier. It has been accepted for inclusion in Theses and Dissertations (Comprehensive) by an authorized administrator of Scholars Commons @ Laurier. For more information, please contact scholarscommons@wlu.ca.

Investigating balance-enhancing effects of midsole hardness and thickness for older adult
footwear

by

Elizabeth A. McLeod

Honours Bachelor of Science, Kinesiology and Physical Education
Wilfrid Laurier University, 2014

THESIS

Submitted to the Department of Kinesiology and Physical Education
in partial fulfilment of the requirements for

Master of Science in Kinesiology

Wilfrid Laurier University

© Copyright by Elizabeth A. McLeod 2016

Investigating balance-enhancing effects of midsole hardness and thickness for older adult footwear

Abstract

Falls among older adults (OA) is becoming increasingly more prevalent. One third of OA fall each year; of those fallers, 20-30 percent endure various injuries — fatal and nonfatal. Older women are especially at risk and are twice as likely than men to sustain a fatal injury following a fall, including severe hip fractures. This study aimed to explore and confirm balance-enhancing evidence for thin and hard midsoles/insoles through an experimental environment with a single data collection session. It was hypothesized that balance would improve while wearing hard insoles in combination with a hard midsole when compared to standard insole and barefoot conditions during inclined walking by providing increased somatosensory feedback on the sole of the foot and mechanical advantage. Nine (n=9; mean age=71.7, 65-81 years) female OA completed various walking tasks including gait termination (GT), normal walking (NW), and cognitive walking (CW) along a 2 m inclined walkway. Participants completed these walking trials while either wearing footwear with standard insoles, wearing the same footwear with hard insoles, or walking barefoot. The cognitive task that was required to be completed by the participants during walking trials included counting in reverse order by multiples of seven beginning from a 4-digit number. Multiple variables were examined to determine overall balance and stability including maximum and minimum medial/lateral (ML) center of mass (COM) - center of pressure (COP) differences (COM-COP), vertical force rates of loading (ROL), step widths, step lengths, and average gait velocity differences between steps. Analysis was performed on the first three steps that were completed on the beginning of the inclined walkway. Results indicated that ML COM-COP differences within GT and NW were significantly different

between footwear conditions. No significant differences were found for ROL during the final single stance prior to GT. Various significant findings for step widths and step lengths were found across all three walking conditions. Change in average gait velocity between two steps at the beginning of the inclined walking during GT was significantly greater during the barefoot condition. Results indicated that midsole hardness influences balance and stability for older female adults during inclined walking. In conclusion, a hard midsole in combination with a hard insole may contribute to overall dynamic balance control.

Acknowledgements

Most importantly, I would like to deeply thank my supervisor, Dr. Stephen Perry, for his mentorship throughout this masters degree. Without his guidance and wisdom through every academic or life situation over the years, I would not be as successful as I have become today. Words cannot amount to my appreciation for his doings.

I would also like to thank my family members for their unconditional love and support throughout this degree. Living over 800 km apart from one another comes at a price. Thank goodness for the invention of the telephone and their patience for all the late night calls and for the calls when I hardly said more than two words.

I would also like to thank my thesis advisory committee, Dr. Paula Fletcher and Dr. Michael Cinelli, for their additional guidance and encouragement. Their doors were always open for discussion whether that involved academic concerns, mental and/or emotional support, or to even complement each other on our new shoes.

Thank you to the students and research assistants within the biomechanics laboratory that assisted in timely data collection sessions, recruitment procedures, and data analyses.

Last but not least, to my friends. Thank you for all the late night cafe work sessions, the climbing sessions, and the nights of endless dancing. Thank you to my best friend, Akiesha, for being my sister from another mister. I could not have survived this degree if it was not for our frequent tea visits, spa days, nature walks with the pups, and retail therapy sessions.

Support would be the understatement of the century to describe the effect these people have had on me during this time in my life.

Table of Contents

Title	Page
Abstract.....	i-ii
Acknowledgements.....	iii
List of Tables.....	v
List of Figures.....	iv
Introduction.....	1-14
<i>Literature Review</i>	1-5
<i>Cognitive Task Influence on Walking</i>	5
<i>Balance and Stability Measurements</i>	5-6
<i>Footwear in Relation to Balance and Stability</i>	6-10
<i>Footwear Misconceptions and Concerns</i>	10-13
<i>Purposes and Hypotheses</i>	13-14
Methods.....	15-26
<i>Participants and Exclusion/Inclusion Criteria</i>	15-17
<i>Insoles Tested</i>	17-18
<i>Equipment</i>	18
<i>Data Collection Sessions</i>	19-22
<i>Variables of Interest Measured</i>	22
<i>Data Analysis</i>	22-24
<i>Statistical Analysis</i>	25-26
Results.....	27-40
<i>Gait Termination</i>	27-33
<i>Normal Walking</i>	33-37
<i>Cognitive Walking</i>	37-40
Discussion.....	41-46
<i>Gait Termination</i>	41-43
<i>Normal Walking</i>	43-45
<i>Cognitive Walking</i>	45-46
Conclusion.....	46-47
Limitations.....	47-49
Future Research.....	49
References.....	50-54
Appendices.....	I-XVIII
<i>Appendix A: Screening Questionnaire</i>	I-IV
<i>Appendix B: Physical Activity Questionnaire</i>	V
<i>Appendix C: Activities-specific Balance Confidence (ABC) Scale Questionnaire</i>	VI
<i>Appendix D: Berg Balance Scale Test</i>	VII
<i>Appendix E: Montreal Cognitive Assessment (MoCA) Test</i>	VIII-XI
<i>Appendix F: Footwear Assessment Form</i>	XII-XIII
<i>Appendix G: Results Tables</i>	XIV-XVIII

List of Tables

Table	Page
1: <i>Participant demographics and test scores</i>	15
2: <i>Monofilament sensitivity scores</i>	20
3: <i>Maximum ML COM-COP analysis between footwear conditions for L2 stance of GT</i>	XIV
4: <i>Minimum ML COM-COP analysis between footwear conditions for L2 stance of GT</i>	XIV
5: <i>Vertical force loading rate analysis between footwear conditions for L2 stance of GT</i>	XIV
6: <i>Vertical force loading rate analysis between footwear conditions for R3 stance of GT</i>	XIV
7: <i>Step width analysis between footwear conditions for L2step of GT</i>	XIV-XV
8: <i>Step width analysis between footwear conditions for R3 step of GT</i>	XV
9: <i>Step length analysis between footwear conditions for L2 step of GT</i>	XV
10: <i>Step length analysis between footwear conditions for R3 step of GT</i>	XV
11: <i>Average gait velocity difference analysis between footwear conditions between R2 and L2 stances of GT</i>	XV
12: <i>Maximum ML COM-COP analysis between footwear conditions for R3 stance of NW</i>	XVI
13: <i>Minimum ML COM-COP analysis between footwear conditions for R3 stance of NW</i>	XVI
14: <i>Vertical force loading rate analysis between footwear conditions for R3 stance of NW</i>	XVI
15: <i>Step width analysis between footwear conditions for R3 step of NW</i>	XVI
16: <i>Step length analysis between footwear conditions for R3 step of NW</i>	XVI-XVII
17: <i>Maximum ML COM-COP analysis between footwear conditions for R3 stance of CW</i>	XVII
18: <i>Minimum ML COM-COP analysis between footwear conditions for R3 stance of CW</i>	XVII
19: <i>Vertical force loading rate analysis between footwear conditions for R3 stance of CW</i>	XVII
20: <i>Step width analysis between footwear conditions for R3 step of CW</i>	XVII
21: <i>Step length analysis between footwear conditions for R3 step of CW</i>	XVII-XVIII

List of Figures

Figure	Page
1: Representation of physiological systems that contribute to balance and stability with corresponding perturbations.....	2
2: Display of COM-BOS relationship of the lateral BOS border and the resulting stability margin.....	3
3: Balance-enhancing footwear characteristics for older adults.....	7
4: Footwear characteristics and corresponding balance effects through deviation measurements. Raised heel heights are the only known significant footwear characteristic that negatively affects balance and stability in OA.....	7
5: Inclined walkway apparatus used during data collection sessions.....	19
6: Eleven marker model set-up used during data collection using Northern Digital OptoTRAK Certus motion capture system.....	19
7: Aerial view of inclined walkway apparatus used during data collection sessions and subsequent stepping pattern produced by each participant for all walking trials.....	25
8: Example of pressure data of stepping pattern during normal walking trial.....	25
9: Example of pressure data of stepping pattern during gait termination trial.....	25
10: Maximum ML COM-COP comparisons for L2 stance between footwear conditions of GT...27	27
11: Minimum ML COM-COP comparisons for L2 stance between footwear conditions of GT...28	28
12: Vertical force loading rate comparisons for L2 stance between footwear conditions of GT..29	29
13: Vertical force loading rate comparisons for R3 stance between footwear conditions of GT..30	30
14: Step width comparisons for L2 step between footwear conditions of GT.....	30
15: Step width comparisons for R3 step between footwear conditions of GT.....	31
16: Step length comparisons for L2 step between footwear conditions of GT.....	32
17: Step length comparisons for R3 step between footwear conditions of GT.....	32
18: Change in velocity comparisons between R2 and L2 stances between footwear conditions for GT.....	33
19: Maximum ML COM-COP comparisons for R3 stance between footwear conditions of NW..34	34
20: Minimum ML COM-COP comparisons for R3 stance between footwear conditions of NW..35	35
21: Vertical force loading rate comparisons for R3 stance between footwear conditions of NW..35	35
22: Step width comparisons for R3 step between footwear conditions of NW.....	36
23: Step length comparisons for R3 step between footwear conditions of NW.....	37
24: Maximum ML COM-COP comparisons for R3 stance between footwear conditions of CW..37	37
25: Minimum ML COM-COP comparisons for R3 stance between footwear conditions of CW..38	38
26: Vertical force loading rate comparisons for R3 stance between footwear conditions of CW..39	39
27: Step width comparisons for R3 step between footwear conditions of CW.....	39
28: Step length comparisons for R3 step between footwear conditions of CW.....	40

Introduction

Literature Review

Falls have become a significant issue among the older adult population. Injuries resulting from a fall encompass much of our health care costs for older adults (OA) (Centers for Disease Control and Prevention, 2015). One third of OA fall each year; of those fallers, 20-30 percent endure various injuries — fatal and nonfatal (Centers for Disease Control and Prevention, 2015). Those fallers aged 75 years and older are four to five times more likely to be admitted into long term care for at least one year than those aged 65-74 years (Donald & Bulpitt, 1999). Of great concern is that older women are twice as likely than men to sustain a fatal injury following a fall, including severe hip fractures (Canada, 2012). Therefore, as more falls may have the potential to be prevented among older women, hospital stays and mortality rates have potential to decrease. Considering results indicate that women report more falls and regularly attend doctor visits (Brett & Burt, 2001), then it may be possible that women are more likely to have higher efficacy to complete the requirements for this particular thesis footwear study. Older adults fall for various reasons including decreased somatosensory feedback, vision loss, neurological disorders, musculoskeletal disorders, vestibular disorders, chronic diseases, circulatory impairments, improper footwear, uneven surfaces, etc. (Maki & McIlroy, 1996; Perry, 2006). Those with any of these disorders are at a higher risk of falling than the healthy OA population. As the leading cause of injury among OA, it is clearly illustrated from the list of causes that falling is multifaceted and thus difficult to prevent.

Research analyses associate any mechanical, neural or physiological impairments that effect the central nervous system (CNS) in OA with an increased risk of falling through various postural stability measurements (Lugade, Lin, & Chou, 2011; Maki & McIlroy, 1996; Massion,

1994) during static and dynamic tasks (Maki, Edmondstone, & McIlroy, 2000; Menz & Lord, 2005). Postural sway is often analysed to determine one's falls risk (Maki & McIlroy, 1996; Massion, 1994). Through proprioceptive and orientation feedback, the musculoskeletal, neural, and sensory systems simultaneously stabilize the body in an upright position against gravitational forces (Figure 1).

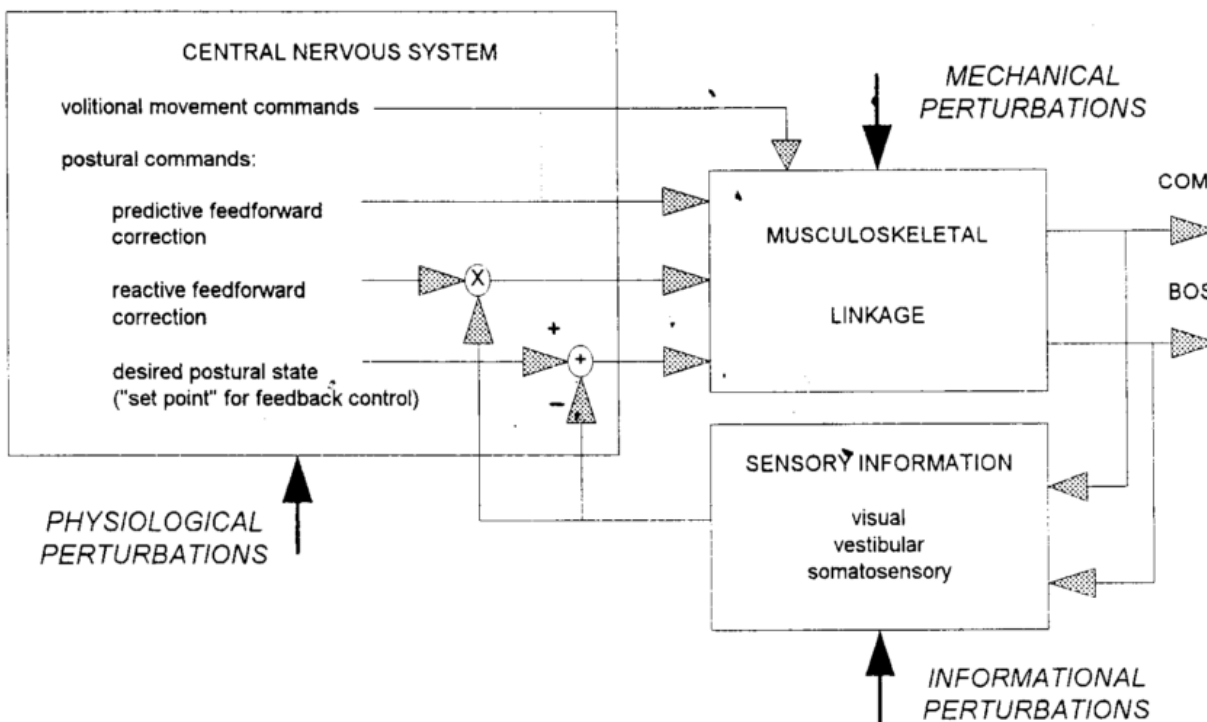

Figure 1: Representation of physiological systems that contribute to balance and stability with corresponding perturbations (Maki & McIlroy, 1996).

Immediate recovery from postural instability can be accomplished by joint torques or anticipatory postural adjustments, generated by muscle groups surrounding each joint to oppose gravitational forces (Maki & McIlroy, 1996). However, if the magnitude and velocity of these forces are too great, a compensatory step or reach and grasp is produced to prevent a fall and increase the base of support (BOS) — the contact between one's body and the surface area of their surroundings — to encompass the new center of mass (COM) — a single point in space

comprised of the summation of one's mass and spatial location — location (Figure 2) (Lugade et al., 2011; Maki & McIlroy, 1996; Pai, Maki, Iqbal, McIlroy, & Perry, 2000).

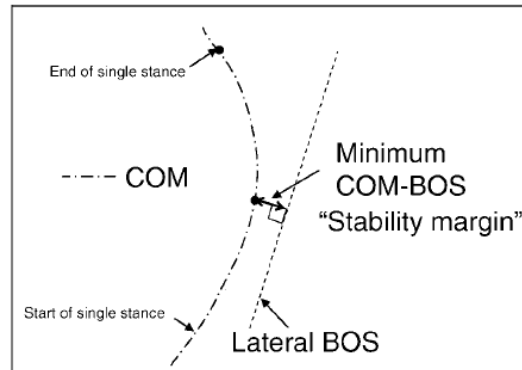

Figure 2: Display of COM-BOS relationship of the lateral BOS border and the resulting stability margin (Perry, Radtke, McIlroy, Fernie, & Maki, 2008).

While standing quietly (static) or walking at a steady pace (dynamic) OA display an increase in postural sway in all directions, most significantly in the medial/lateral (ML) direction (Maki & McIlroy, 1996). This instability is further pronounced when OA are perturbed while standing or performing a gait task. Researchers examined OA compensatory stepping reactions when unexpectedly perturbed during quiet standing and walking (Maki et al., 2000). OA displayed stepping patterns that were vastly different compared to young adults (YA). OA tended to increase the amount of steps taken and utilize a shuffling step as opposed to the crossover step like YA. This stepping behaviour is thought to be the result of underlying impairments involving the body's neural, musculoskeletal, and sensory systems (Maki & McIlroy, 1996). Although not an exhaustive explanation, these impairments could be the result of age-related degenerations in all bodily systems or from any physical injury or physiological condition such as a stroke, effecting the nervous system and subsequent musculoskeletal functions. Researchers demonstrated that there are significant negative effects of moderate to severe hallux valgus on stability and gait patterns of OA, including slower gait velocity and shorter step length,

especially when walking over uneven terrain (Menz & Lord, 2005). Decreased muscle strength is also often associated with this lack of balance recovery since OA tend to experience muscle atrophy with either a decrease in physical activity or lack of mobility due to an impairment or detrimental health condition. The lack of muscle strength also increases the reaction time in which one can recover from a perturbation in static and dynamic situations, since the muscles lack the ability to contract efficiently and effectively to position the limbs so that the COM remains or returns within the BOS either during static standing or during locomotion with a dynamic BOS (Lugade et al., 2011; Maki & McIlroy, 1996).

However, muscles can only react as quickly as instability is detected and corrected through the body's nervous system. Mechanoreceptors in the plantar surface of the foot are end organs that detect pressure changes in the skin, with some mechanoreceptors on specific sections of the sole of the foot more sensitive than others; i.e., mechanoreceptors in the heel are typically less sensitive than those in the rest of the sole of the foot (Kennedy & Inglis, 2002; Perry, 2006). These sensors send feedback to the CNS describing one's changing postural stability. However, if these mechanoreceptors lack sensitivity to miniscule pressure changes underneath the foot due to degradation as a result of age or mechanical damage, such as from wearing improper footwear, then this pressure must be increased for the CNS to recognize the increased risk of falling due to postural instability (Perry et al., 2008). Other systems, such as visual and vestibular, assist in the reaction to instability or a perturbation, but research demonstrates that vestibular and especially somatosensory feedback are typically the most significant contributors to balance control (Horak, Nashner, & Diener, 1990). However, visual feedback should not be discounted when examining OA balance and stability. As these systems are eliminated or

diminished, comparable to the degradation that occurs with age, these deficiencies are threatening to balance control (Horak et al., 1990).

Cognitive Task Influence on Walking

Cognition has also displayed to be a significant factor in OA balance control during gait (Moghadam et al., 2011; Rogers, 2003). OA tend to produce decreased postural stability during gait when cognitive load is increased. Typically, physicians and researchers have relied on using the Mini-Mental State Exam (MMSE) (Folstein, Folstein, & McHugh, 1975) and the Standardize MMSE (Vertesi et al., 2001) to determine an individual's cognitive function. However, recent literature has explored the capabilities of the Montreal Cognitive Assessment (MoCA). The MoCA test has consistently been utilized to determine cognitive function level for research and clinical purposes (Appels & Scherder, 2010; Ismail, Rajji, & Shulman, 2010; Jacova, Kertesz, Blair, Fisk, & Feldman, 2007; Lonie, Tierney, & Ebmeier, 2009). Validation and reliability of the MoCA examination has been demonstrated to conclude that this test is exceptional when determining cognitive function utilizing a more holistic approach as there are versions of this cognitive assessment for different populations including those with mild cognitive impairments (Freitas, Simoes, Maroco, Alves, & Santana, 2012).

Balance and Stability Measurements

Typically, COM-BOS and COM - center of pressure (COP) relationships allow researchers to determine postural stability (Lugade et al., 2011; Moghadam et al., 2011). The distance between the COM and the outer boundaries of the BOS is commonly known as the stability margin (Figure 2) (Perry et al., 2008). This margin is continuously defined as having two components, spatial and temporal. Spatially, the margin indicates the distance between the

COM and BOS locations and as this distance decreases, so does stability. The velocity at which the COM approaches the BOS limits indicates the amount of time one has to react to any perturbation, known as the temporal stability margin. The COP is also an important indicator of stability during both static and dynamic locomotion tasks. As the COM displaces and approaches the BOS limits, the COP constantly corrals the COM back to a stable position within the current BOS. In other words, COP is a summation of reactive forces that control the COM movement. This correctional system, known as balance control, is always active while standing or walking to keep the body stable in an upright position or to prevent a fall by taking a step during gait, respectively. Moghadam et al. (2011) examined the effects of a cognitive dual-task on static postural stability of OA and confirmed the reliability of utilizing COP measurements to investigate postural stability during dual-tasks.

Footwear in Relation to Balance and Stability

Foot sole sensitivity and gait measurements of the lower extremities have been extensively analysed for their role in balance and stability within fall prevention research for OA. Specific footwear characteristics have displayed improvements in OA balance under static and dynamic conditions to decrease falls risk and number of falls, such as low heel heights, sufficient sole tread, hard and thin midsole cushioning, and facilitating insoles (Figure 3) (Hatton, Rome, Dixon, Martin, & McKeon, 2013; Lindemann et al., 2003; Lord, Bashford, Howland, & Munroe, 1999; Menant, J. C., Perry, S. D., et al., 2008; Menant, J. C., Steele, J. R., Menz, H. B., Munro, B. J., & Lord, S. R., 2008; Menant, Jasmine C., Steele, Julie R., Menz, Hylton B., Munro, Bridget J., & Lord, Stephen R., 2008; Menz & Lord, 1999).

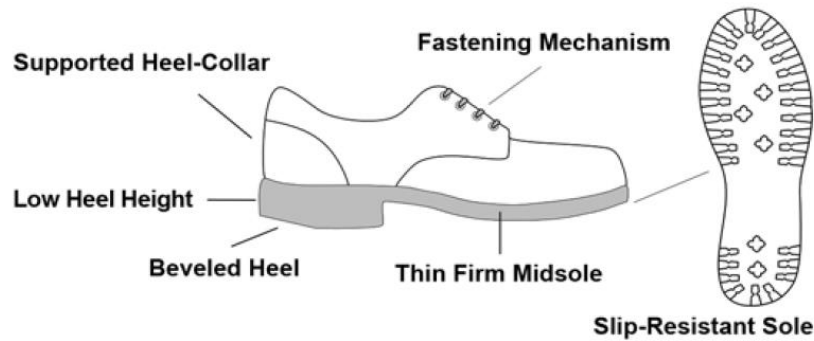

Figure 3: Balance-enhancing footwear characteristics for older adults (Menant, Jasmine C. et al., 2008).

Other characteristics have been demonstrated to be detrimental to OA balance and stability, including an increased heel height, a hard and slippery sole tread, and soft and thick midsole cushioning (Figure 4) (Lord & Bashford, 1996; Menant, J. C., Steele, J. R., et al., 2008).

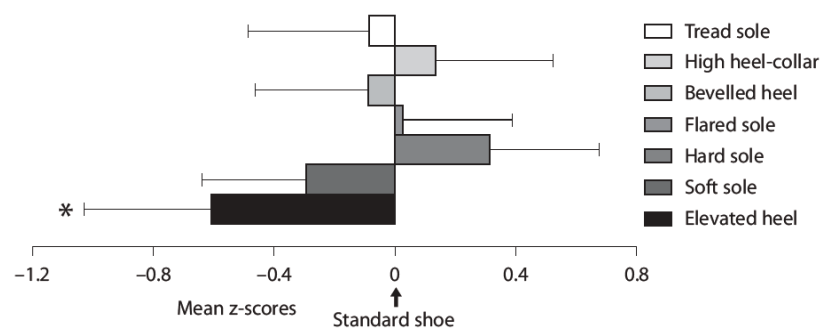

Figure 4: Footwear characteristics and corresponding balance effects through deviation measurements. Raised heel heights are the only known significant footwear characteristic that negatively affects balance and stability in OA (Menant, J. C., Steele, J. R., et al., 2008).

Heel heights above 2.5 cm produce significant balance deficits, drastically increasing OA falls risk (odds ratio: 1.9) (Tencer et al., 2004). Individuals that have consistently worn footwear with heel heights above 2.5 cm may have shortened plantar flexor muscles and tendons, with possible underlying impairments that may be undiagnosed. Weight of footwear may also contribute to balance control as heavy shoes can be a nuisance when attempting to walk efficiently, especially

if an OA suffers from decreased proprioception and a lack of muscle strength, increasing the risk of tripping (Maki & McIlroy, 1996).

As previously mentioned, current research indicates that as one ages, OA's sensitivity of the plantar surface of the foot decreases, thus negatively affecting balance and stability (Massion, 1994; Perry, 2000). A decrease in stability, which is often determined through analysis of postural sway, increases OA's risk of falling. OA's postural sway is often expressed to have greater variability in both the anterior/posterior (AP) and, most significantly, in the ML direction. Considering this lack of stability within the OA population, with majority of findings stating the importance of somatosensory feedback for postural control, it would seem intuitive to improve daily footwear for various activities. However, this rudimentary idea is remarkably underdeveloped with some research supporting balance-enhancing footwear characteristics. Insoles have shown to improve OA's stability by increasing the somatosensory feedback under the plantar surface of the foot (Palluel, Nougier, & Olivier, 2008; Palluel, Olivier, & Nougier, 2009; Perry et al., 2008; Priplata, Niemi, Harry, Lipsitz, & Collins, 2003; Qiu et al., 2012; Stephen et al., 2012; Wang & Yang, 2012). Studies involving facilitating, textured, and vibrating insoles have displayed these improvements in experimental settings. This phenomenon occurred while OA wore facilitating insoles which have a ridge (3mm) on the top of the insole and surrounding the medial, lateral, and posterior perimeter that is designed to increase pressure on the plantar sole of the foot, thus facilitating somatosensory feedback and stability (Perry et al., 2008). Participants that wore facilitating insoles in comparison to those OA who wore standard insoles, for 12 weeks, displayed significant increases in stability while walking over uneven terrain. Findings implied that habituation of the insole balance effects did not occur throughout the intervention. However, textured insoles of varying spike levels demonstrated inconclusive

results. Some studies reported an increase in balance of OA after wearing textured insoles for a certain length of time (Palluel et al., 2008; Palluel et al., 2009; Qiu et al., 2012). Others studies that did not allow the participant to familiarize with the insole texture and began testing immediately after wear did not find any significant enhancements in balance ability for varying static and dynamic tasks using various spike levels across each textured insole (Hatton, Dixon, Martin, & Rome, 2009; Hatton, Dixon, Rome, Newton, & Martin, 2012). These inconclusive results may be due to methodology and insole design differences between studies and thus warrant further research. In addition to textured and ridged insoles, studies using vibrating insoles have displayed a significant increase in overall balance and stability for YA and OA during quiet standing (Priplata et al., 2003; Stephen et al., 2012; Wang & Yang, 2012). However, this technology is not yet realistic for consumers. These assistive devices require high voltage systems, which are attached to delicate wires, making the insoles expensive and inconvenient. Orthotics with cushioning under the 2nd-4th metatarsal joints have reported to successfully decrease foot pain, a common issue with OA (de Morais Barbosa et al., 2013). Along with a few other studies, this specific intervention found improvements in balance and foot pain (Gross, Mercer, & Lin, 2012; Mulford, Taggart, Nivens, & Payrie, 2008).

Midsole cushioning has been studied most often out of all footwear characteristics. It has been well documented that soft and thick midsoles are quite detrimental to OA balance, further increasing their risk of falling. Waked, Robbins, and McClaran (1997) demonstrated through balance beam walking that the number of balance failures for older men significantly decreased when wearing thin (13mm heel, 6.5mm metatarsal phalangeal joints) and hard (Shore A - Scale 50) midsoles, which were held to the barefoot with a sock, encasing both the foot and midsole. In addition to this research, Perry, Radtke, and Goodwin (2007) measured COM, COP, and BOS

relationships and vertical loading rates for four midsole conditions of 12 healthy females (aged 20-23 years), while performing unexpected gait termination trials. Thickness of each midsole remained constant at 1cm, while hardness differed from soft (Shore A - Scale 15), standard (Shore A - Scale 33), to hard (Shore A - Scale 50). Hard midsoles offered the most significant benefits for increasing balance. COM-BOS ML ranges were largest for the hard midsole condition suggesting a decrease in postural restriction. This interpretation is also supported since the AP COM-COP maximum range significantly decreased from barefoot to soft and standard insole conditions (Perry et al., 2007). This finding in addition to a significant increase in vertical loading forces implies that these YA experienced significant instability while wearing soft insoles during gait termination. OA with decreased plantar sole sensitivity and greater instability may display further adverse balance effects, possibly resulting in a fall. COM-BOS relationships were also examined in a stair descent gait study involving OA during various insole conditions (Antonio & Perry, 2014). Barefoot conditions were also confirmed to be quite detrimental to an OA's balance, suggesting that footwear be worn within the household as well as outdoors, as supported by research that determined a substantial amount of falls occurred while barefoot (Horgan et al., 2009; Koepsell et al., 2004).

Footwear Misconceptions and Concerns

Considering the evidence that has been presented to consumers regarding proper footwear, one substantial issue involves OA efficacy to purchase and wear shoes of such characteristics (Borland, Martin, & Locke, 2013; Burns, Leese, & McMurdo, 2002; Munro & Steele, 1999). A preliminary study in the United Kingdom surveyed OA above 80 years and concluded 42.7% of all participants and 80% of those housebound chose to wear slippers both

indoors and outdoors (White & Mulley, 1989). Slippers are typically constructed of very soft and thick soles, with either open or closed heels, which comprise inadequate footwear and inevitably increase OA risk of falling. A recent study in England observed the footwear choices of OA admitted into a hospital (Vass, Edwards, Smith, Sahota, & Drummond, 2015), slippers (46%) and socks with grips on the soles (37%) were the most common footwear choices with more than half of the remaining footwear choices defined as unstable with a significant lack of support. Comparing the results of these footwear studies implies that footwear choices among OA have remained consistent over a 26-year period. Reasons for footwear currently worn could include a range of explanations, including comfort, cost, or aesthetics (Davis, Murphy, & Haines, 2013; Munro & Steele, 1999). Custom shoes can be quite expensive if an OA required a wider and tailored shoe due to deformities and widening of the foot as one ages. As such, slippers are low in cost and, due to comfort, are often purchased as the ideal footwear among the OA population (Munro & Steele, 1999). However, for some OA, fashion seems to take precedence over comfort and safety, which typically involves high heels and narrower toe boxes (Burns et al., 2002; Davis et al., 2013; Menz & Morris, 2005). It is often assumed that foot shape remains constant as one ages; however, the opposite is true in that most OA feet become wider with age while most OA failing to measure their foot size on a regular basis with progressing years (Chantelau & Gede, 2002; Mickle, Karen Julie, Munro, Bridget J., Lord, Stephen R., Menz, Hylton B., & Steele, Julie R., 2010; Munro & Steele, 1999). Modern footwear is often narrow and does not attend to the shape of an OA's foot. In addition to negatively affecting OA's stability, these footwear choices among OA most often cause foot deformities that can be painful, further altering gait to avoid discomfort, decreasing stability (Mickle, K. J., Munro, B. J., Lord, S. R., Menz, H. B., & Steele, J. R., 2010). All of these footwear characteristics add to the advancement of creating proper

footwear recommendations to OA. Of those OA who have experienced fall-related hip fractures, a small sample of 95 OA was investigated for footwear worn at the time of the fall (Sherrington & Menz, 2003). Overall, majority (75%) of the footwear reported worn during the time of the fall were characteristic of at least one possible balance-deficit feature. Twenty percent of these sub-optimal shoes were manufactured with soft soles. Out of all falls reported for this study, twenty two percent of the footwear worn during the fall were slippers — shoes that lacked fixation, which in turn, lack of fixation accounted for sixty three percent of these less than ideal choices of footwear (Sherrington & Menz, 2003). A review of footwear literature and related foot pathologies within the OA population determined that above 80% of OA have foot pathologies that are often due to the use of ill-fitting footwear. Sometimes ill-fitting footwear can be characteristic — but not limited to — tightly fitted lengths and widths in comparison to the foot, low toe boxes that minimize toe space, and minimal or absent arch support (Ikpeze, Omar, & Elfar, 2015).

One important possible explanation for this recurring phenomenon of ill-fitting OA footwear is the perception of balance-enhancing footwear characteristics. However, limited research has been conducted to determine this knowledge. A study performed in the United Kingdom extracted the knowledge of nurses within long term care facilities about which type of footwear OA should be wearing (Borland et al., 2013). Although there were no set guidelines for nurses to recommend footwear for OA in the United Kingdom, most nurses (80%) responded with accurate knowledge based on current footwear literature regarding appropriate footwear for falls prevention among OA. However, the remaining 20% of nurses were unknowledgeable of such recommendations. Some nurses' responses were even incorrect recommendations. These misconceptions are a growing concern and must be taken into consideration when recommending

appropriate footwear to OA. Furthermore, healthcare facilities should diligently and routinely inform their employees of the most current footwear recommendations derived from empirical evidence. Although this information is somewhat nebulous and may not be readily available to the public, some recommendations have been compiled into reviews (Hatton et al., 2013; Menant, J. C., Steele, J. R., et al., 2008; Menant, Jasmine C. et al., 2008; Menz & Lord, 1999). Follow up procedures to ensure these employees implement informed recommendations properly should be practiced.

Purposes and Hypotheses

Although fall prevention research has advanced in determined balance-enhancing characteristics of footwear for OA, this concept has yet to be extensively explored to display significant balance-enhancing footwear characteristics. This study aimed to explore and confirm balance-enhancing evidence for thin and hard insoles through an experimental environment with a single data collection session. It was hypothesized that balance would improve while wearing the test insoles when compared to no insole and barefoot conditions for all inclined walking conditions including normal walking (NW), gait termination (GT), and cognitive walking (CW). The test insoles were hypothesized to provide increased somatosensory feedback on the sole of the foot and mechanical advantage, which in turn would result in increased balance and stability.

Relationships between maximum and minimum ML COM-COP measurements would present the most stability during insole conditions. This stability would be identified if the ML COM-COP maximum and corresponding minimum differences were both small values during a single stance phase. This was hypothesized to be true for all walking conditions.

During GT trials, vertical force loading rates were hypothesized to display the most stability during the test insole condition. This would be indicated if the second last step prior to termination of gait produced the highest loading rate out of all footwear conditions as the braking force to prepare for completion of GT during the last step. Loading rates during the final step of GT would then be lowest between footwear conditions to indicate that the slowing of average gait velocity would be the most efficient during the insole condition requiring the least amount of braking force at termination of gait.

Instability would also be indicated if step lengths and step widths were shorter and wider, respectively. It was hypothesized that step lengths and widths would be longest and the narrowest during the insole condition indicating the most stable condition during all walking conditions.

Differences in average gait velocity between the last and second last steps of GT would display increased stability if the insole condition produced velocity differences lower than those differences within the no insole and barefoot conditions.

Methods

Participants and Exclusion/Inclusion Criteria

Nine (n=9; mean age=71.7, 65-81 years; Table 1) female OA were recruited to participate in this study. All participants were healthy, community dwelling OA within the Kitchener-Waterloo region, aged 65-84 years. Only females were recruited for participation for various reasons including increased injury risk following a fall, the increased amount of older female adults compared to those that are male, and an increased tendency to report health issues (Brett & Burt, 2001). Screening questionnaires (Appendix A) were completed, prior to the study, via telephone to ensure that all participants were free of any clinically diagnosed neurological or vestibular conditions that may affect their balance or cutaneous sensation and had only fallen once or less within the last year, which is identified as a healthy OA for the purposes of this study. If participants in fact had any of these conditions or sustained any injuries that may affect their balance, they were excluded from participation in this study. Following completion of the screening questionnaire via telephone, all eligible participants were required to attend the Biomechanics lab to complete a screening session to determine full eligibility for the study, prior to scheduling of the data collection session. The screening session included completing the Berg Balance Scale Test (Appendix D), balance confidence (Appendix C) and physical activity (Appendix B) questionnaires, and the Montreal Cognitive Assessment (MoCA) test (Appendix E). All participants in this study displayed sufficient balance abilities and cognitive function prior to the study through the completion of the screening assessments and questionnaires.

Table 1: Participant demographics and test scores. Participants displayed very good balance through completion of the BBS, normal cognitive abilities through completion of the MoCA and excellent balance confidence expressed through the ABC.

n=9	Age (years)	Weight (kg)	Height (m)	BBS	MoCA	ABC (%)
Mean	71.7	64.3	1.50	55.4	27.2	91.7
Range	65-81	47-95	1.16-1.63	53-56	24-30	84.4-99.3

Through the completion of the physical activity questionnaire, all participants claimed to be regularly physically active at moderate intensities. If cognitive function displayed a score indicative of significant cognitive decline, which, according to MoCA guidelines, is defined by any individual that receives a score below 26, individuals were excluded from further participation in this study. However, the primary investigator used discretion when excluding these individuals since two OA received a score of 24. If the participant could count backwards by 7's with minimal effort and were only slightly below the MoCA threshold for cognitive decline then participants were still included in the study if the remaining screening criteria was met. Reason for exclusion due to significant cognitive decline consisted of evidence that cognitive effort is significantly increased in OA as compared to YA during the completion of cognitive tasks (Lindenberger, Marsiske, & Baltes, 2000). OA were also excluded if their habitual footwear mainly consisted of footwear with heel heights above 2.5cm. Only two volunteers that were interested in participating in the study were excluded due to their choice to consistently wear footwear with heels above 2.5cm. In addition, OA who require prescription orthotics were excluded, since orthotics are most commonly used to significantly decrease foot pain, a common issue with OA for various reasons (de Morais Barbosa et al., 2013; Mulford et al., 2008). As defined by the Manchester scale, if applicable, severity of hallux valgus of each participant would have been measured by the primary investigator and those with moderate to severe conditions would have been excluded. No participants involved in the study displayed any form of hallux valgus; thus, the Manchester scale was not needed for screening. During the screening session performed in the biomechanics laboratory prior to the separately scheduled data collection session, the principal investigator examined approximately 2-4 pairs of each

participant's daily footwear. Utilizing footwear literature and a Footwear Assessment Form (Appendix F) (Menz & Sherrington, 2000), one pair of personal footwear of each participant was chosen for insole wear, based on proper footwear recommendations for balance-enhancement of OA. Durometer measurements (hardness levels of the material) were taken to ensure the midsoles (between standard (Shore A - Scale 33) and hard (Shore A - Scale 50)) and soles (no less than standard hardness) of the shoes chosen were within the acceptable range of hardness to prevent instability. Feet were required to be fully enclosed with a rigid heel counter to provide support for the ankle joint and a collar height just below the malleoli to prevent the heel from slipping. The toe box of all footwear had sufficient width, length, and height to allow room for slight toe movement, preventing any rubbing or curling of the toes. Shoes were fastened with laces to ensure a snug fit to the feet, preventing any slipping or rubbing in the shoe. Nine participants were recruited for this study and approximately twenty were excluded due to the above screening criteria.

Insoles Tested

Two types of insoles were investigated. The first insole condition was the standard (approx. Shore A - Scale 33) insole that was included with each participant's habitual footwear. The second insole (test insole) (Model: QFIT PUFF Blue) of main interest was chosen from production insoles obtained from Vittoria Phoenix (Vittoria, ON, Canada) based on characteristics that are recommended by footwear literature. The test insole was thin (3 mm) and hard (Shore A - Scale 50), as supported by multiple experimental studies (Losa Iglesias, Becerro de Bengoa Vallejo, & Palacios Pena, 2012; Perry et al., 2007; Robbins, Gouw, & McClaran, 1992; Waked et al., 1997). The test insoles were fabricated of ethylene-vinyl-acetate, which was

consistent with footwear literature (Losa Iglesias et al., 2012). All test insoles were trimmed, if needed, to fit each participant's shoe size, without depreciating the integrity of the insole. All participants were required to come in for one data collection session.

Equipment

Wireless equipment was utilized for the data collection of this study. Fitted pressure sensor insoles (Medilogic, Schönefeld, Germany) were placed in each shoe to measure pressure distribution and total pressure. A sampling frequency of 300Hz was used to collect these kinetic measurements. These insoles are very thin and are negligible to plantar sensation, thus they did not affect stability. A three-dimensional motion capture system (OptoTRAK Certus, Northern Digital, Waterloo, ON, CAN) was used to track the movement of the markers placed on the participants during trials (sampling frequency 100 Hz). The motion capture system was positioned in line with the participant's walking path on the 2 meter (m) inclined walkway (Figure 5) to track the movement of the markers placed on the body. An 11-marker model (Figure 6) was used to track body movement and estimate center of mass and location the changing location of the base of support throughout each trial. Markers were placed on the posterior side of the body at the T12 vertebra, left and right shoulders, hips, ankles, heels, and 5th metatarsals.

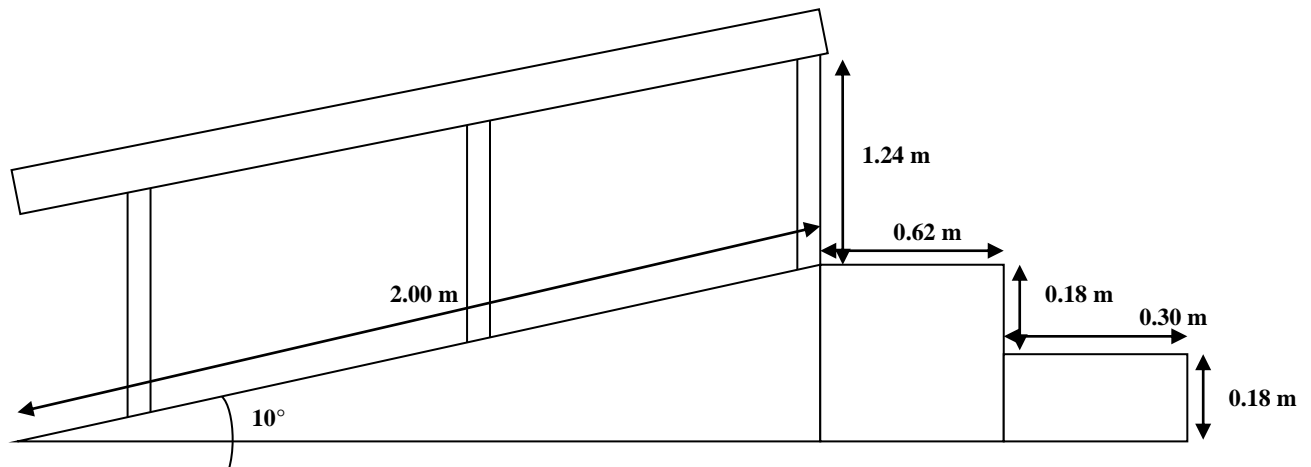

Figure 5: Sagittal view of inclined walkway apparatus used during data collection sessions.

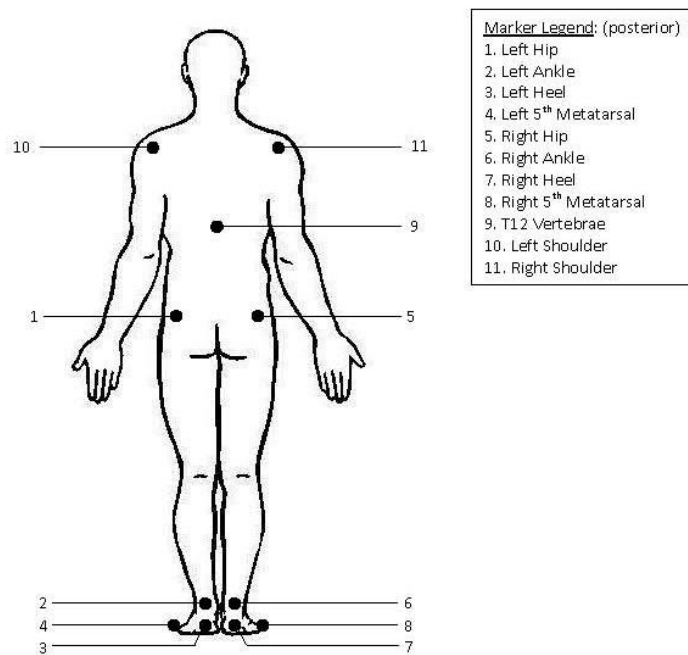

Figure 6: Eleven marker model set-up used during data collection using Northern Digital OptoTRAK Certus motion capture system.

Data Collection Sessions

Once verbal consent was received from each participant via telephone, each participant completed a screening questionnaire (Appendix A) to determine initial eligibility for this study. This questionnaire determined if any participant had any health conditions that may affect the nervous, musculoskeletal, or vestibular system causing the participant to have balance issues.

Once ensured that each participant did not have any health conditions that affected their

balance abilities, they were invited to attend the biomechanics laboratory for a balance screening session to determine complete eligibility for this study. Following informed consent, participants completed various questionnaires including details about their current physical activities (Appendix B), the Activities-specific Balance Confidence Scale (Appendix C) questionnaire, and the MoCA test for a cognitive evaluation (Appendix D). To examine overall balance ability, as determined as one of two highly recommended tests, the Berg Balance Scale (BBS; Appendix E) was used to determine participant standing balance ability (Sibley et al., 2015). The BBS is both reliable and convenient as supported by its use in numerous experimental protocols and the ability to perform the test in any setting, within or outside a laboratory. Measurements of each participant's habitual footwear presented were taken as per the Footwear Assessment Form (Appendix F) and a suitable pair of shoes were chosen for each participant to wear with the test insoles provided by the researcher.

Prior to the first data collecting session (separately scheduled from the screening session) and following informed consent from each participant, sensitivity of the plantar sole of the foot was measured using monofilaments to ensure sensation was within the typical range for OA, reaffirming no presence of any abnormal sensitivity conditions. The primary investigator depressed the monofilament fiber against the plantar sole of the right foot in four locations — great toe, 1st metatarsal, 5th metatarsal, and heel (Table 2).

Table 2: Monofilament sensitivity scores.

	Great Toe	1st Metatarsal	5th Metatarsal	Heel
Mean	3.59	3.81	3.81	4.15
Range	2.83-4.08	3.22-4.17	3.22-4.31	3.61-4.74

OA, with eyes closed, indicated to the researcher if they felt pressure under their foot by saying 'yes' or remaining silent if they did not feel each monofilament. The resulting sensitivity

measurement was determined as the last 'yes' response to the lowest amount of pressure detected by the participant. Anthropometric measurements of the participant's marker placements on the body was recorded including the height, posterior, lateral, and frontal distances of each marker (Figure 6).

Walking trials commenced once participants were equipped with appropriately sized pressure sensor insoles and infrared markers. Participants were required to walk up a 2m slope set at an inclination of 10° (Figure 5), in accordance with previously used methodologies (Ferraro, Pinto-Zipp, Simpkins, & Clark, 2013; Leroux, Fung, & Barbeau, 2002; McIntosh, Beatty, Dwan, & Vickers, 2006). Always beginning with the right foot for all walking trials, participants took two steps (one right and one left step) along a flat tiled floor leading up to the walking apparatus and then adapted to the inclined walking surface as they walked along the slope gazing forward on the wall at eye level beginning on the incline with the right foot (Figure 7). This allowed for a consistent walking pattern between trials between participants allowing for more accurate data analysis. An inclined walkway was utilized because it has been demonstrated that OA tend to use a more cautious gait pattern while walking up inclined walkways implying that inclined slopes challenge OA dynamic stability (Ferraro et al., 2013). Participants completed some of these inclined slope walking trials while performing a cognitive task, since stability has been known to decrease during postural tasks as cognitive demand increases especially for OA (Rankin, Woollacott, Shumway-Cook, & Brown, 2000; Rogers, 2003). This cognitive task was implemented in the methodology to serve as a distraction from the walking task at hand to invoke a balance perturbation. OA were cognitively challenged by silently counting backwards by intervals of seven from a randomly selected four-digit number as they walked along the inclined surface. At the end of each cognitive trial, participants were required to report their final

number to ensure the task was completed properly. Encouragement and instructions on how to complete this cognitive task were reiterated to participants by the researcher before each cognitive trial. Another walking condition incorporated was unexpected gait termination on the slope. If the participant heard the sound of a door bell (audio cue) while walking on the slope, they were required to stop as quickly as possible to a quiet stance position and remain stable until told otherwise. The audio cue was triggered manually by the researcher when participants took their first step (second right step after gait initiation at beginning of trial) on to the inclined surface. Participants were instructed to attempt to stop within two steps following the audio cue allowing participants to take three steps on the inclined walkway before terminating gait (Figure 7). This termination of gait was produced unexpectedly as the participants were unaware of which trial the audio cue would occur, forcing participants to walk normally for each walking trial.

Variables of Interest Measured

Kinematic and kinetic measurements collected were utilized to determine participants' average gait velocities, step widths, step lengths, vertical force loading rates, COM, and COP. COM-COP relationships were examined for all trials to determine stability in the ML direction. Analysis of kinematic data collected, utilizing real-time data collected from a motion-based camera produced stability margins and pressure sensor insole measurements allowed for calculations of these variables.

Data Analysis

Kinematic and kinetic data were synced, with a custom analysis program, using multiple foot contacts identified by foot marker velocities and foot contact timings from force recordings. This enable the comparisons of average gait velocities, step lengths, step widths, and maximum and minimum ML COM-COP relationships for all walking trials. Criteria for all data analysis was coded into the custom analysis program to analyze single stance phases of the side of interest using force and position thresholds for all walking trials. Analysis was performed after the opposite foot toe off and completed following the contact of the opposite foot. Each participant's stepping pattern was initiated in the same manner, stepping once with the right and left feet on a level walkway before stepping with their right foot onto the inclined walkway. Participants were instructed to walk with a normal gait pattern during all trials. Analysis for all walking trials including normal walking (NW), cognitive walking (CW), and gait termination (GT) variables between and within the second right (R2) stance, the second left (L2) stance (second last stance for GT), and the third right (R3) stance (last stance for GT) (Figures 7, 8, & 9). Differences in average gait velocities between the R2 stance and L2 stance were calculated for GT trials because it was thought that this difference would have produced the most change in velocity. The R2 stance may have been the most unstable during GT as the participant transitioned from a 0° walking surface to a 10° inclined walking surface and as they would have reacted to the audio cue which was sounded at foot contact prior to the R2 stance. As such, the L2 stance, following the R2 stance, may have been the largest reactive stance phase following the door bell signal to terminate gait. Therefore, changes in average gait velocity would have been the most significant between the R2 and L2 stances, if significantly produced. Step lengths and widths and vertical force loading rates were calculated for the R3 stance for NW and CW trials and for the L2 and R3 stances for GT trials. Maximums and minimums for the ML COM-

COP differences were calculated during the single stance of the L2 contact for GT trials and of the R3 contact for NW and CW trials. The L2 single stance was thought to be the most significant step during GT because it was the last single stance step prior to termination of gait. The R3 step was thought to be the most stable stance during NW and CW because the R2 stance followed a transition step, the L2 stance followed an initial adaptation step to the 10° incline, and the R3 stance followed the most adapted step to the 10° incline after completed three steps on the inclined walkway. The audio cue was triggered during the R2 stance because it was thought to be the most effective if the perturbation was introduced while the inclined surface already introduced an element of perturbation without the audio cue to terminate gait. This would allow the largest combined perturbation to occur against the participant to decrease their overall stability.

Pressure loading rates for all walking trials for 100ms after initial foot contact were also analyzed utilizing the steps previously mentioned. The average gait velocity was also calculated for each single stance phase using the T12 marker (#9, Figure 6) for all three steps. COM was calculated as a seven segment model using all of the 11 marker positions that were placed on the posterior side of the body. COP calculations were performed using a summation of the pressure values from the insoles with respect to foot marker data.

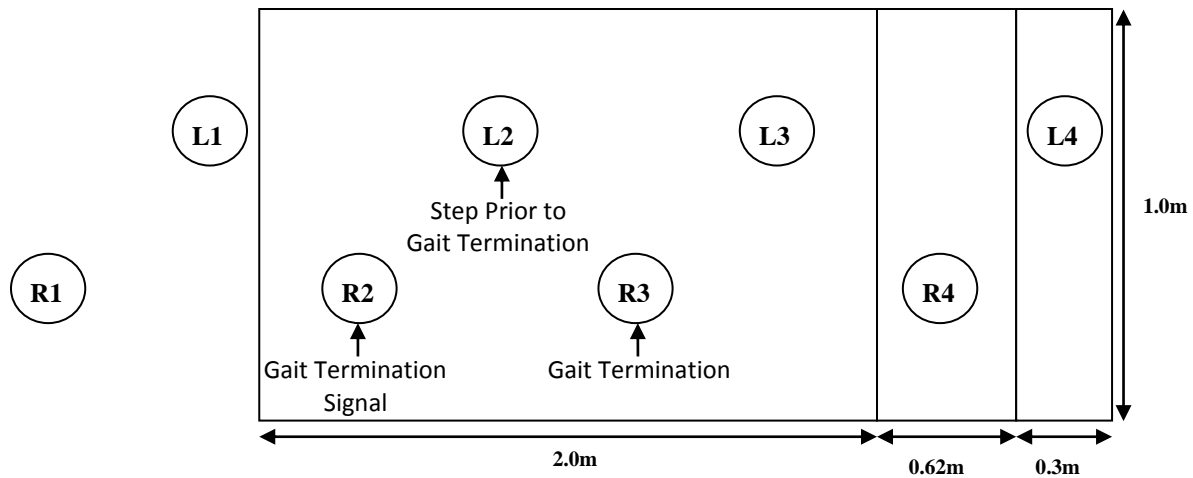

Figure 7: Aerial view of inclined walkway apparatus used during data collection sessions and subsequent stepping pattern produced by each participant for all walking trials (R1 – 1st right step, R2 – 2nd right step, etc – applies to L – left as well).

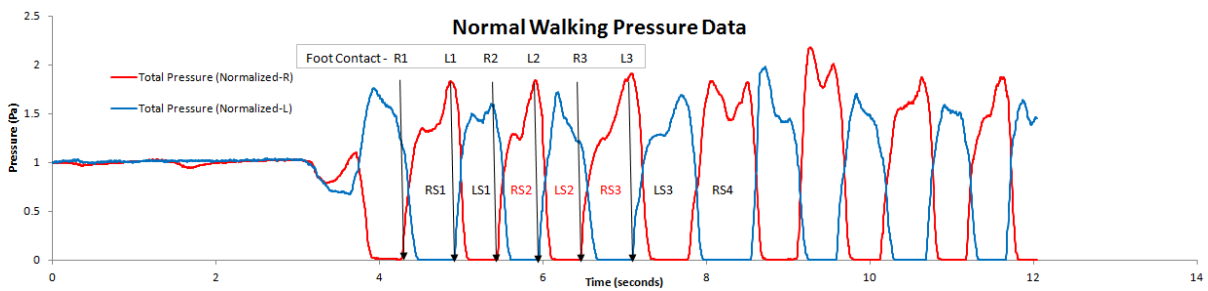

Figure 8: Example of pressure data of stepping pattern during normal walking trial.

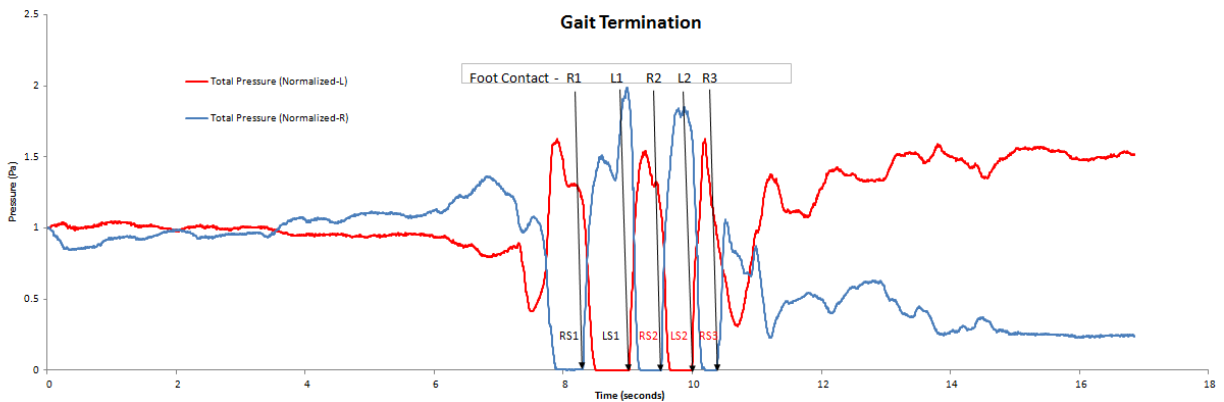

Figure 9: Example of pressure data of stepping pattern during gait termination trial.

Statistical Analysis

One-way repeated measures analysis of variance (ANOVA) statistical tests were performed to determine balance differences between insole conditions within walking

conditions. One-way repeated measures ANOVA tests were performed for GT, NW, and CW trials comparing statistical differences between footwear conditions (no insole, insole, barefoot). Tukey post-hoc tests were performed to determine specific statistical differences between footwear conditions within walking conditions. All significance levels were set a priori at $\alpha=0.05$. Missing data were excluded from analysis. Outliers were identified if measured to be two standard deviations from the mean and only excluded if a marker was missing during any trial, if the pressure data displayed irregular stepping patterns or if participants did not terminate gait during GT trials.

Results

Effect Size

Effect sizes (es) ranged between 0.42 and 0.70 for all significant variable values which indicate large effect sizes (Miles & Shevlin, 2001).

Gait Termination

Medial/Lateral Center of Mass-Center of Pressure (ML COM-COP)

During gait termination (GT), maximum ML COM-COP was calculated during the second left (L2) stance between footwear conditions. The greatest maximum difference between the COM and the COP occurred during the barefoot (0.27 m) condition and the least difference was produced when participants did not wear the test insole (0.22 m). During the insole (0.25 m) condition, these values were between those produced during the no insole and barefoot conditions. Significant differences ($F_{22,77}=8.35$, $p<0.0001$; $es=0.70$) were found between the no insole condition and both insole and barefoot conditions such that the maximum COM-COP difference was significantly smaller during the no insole condition.

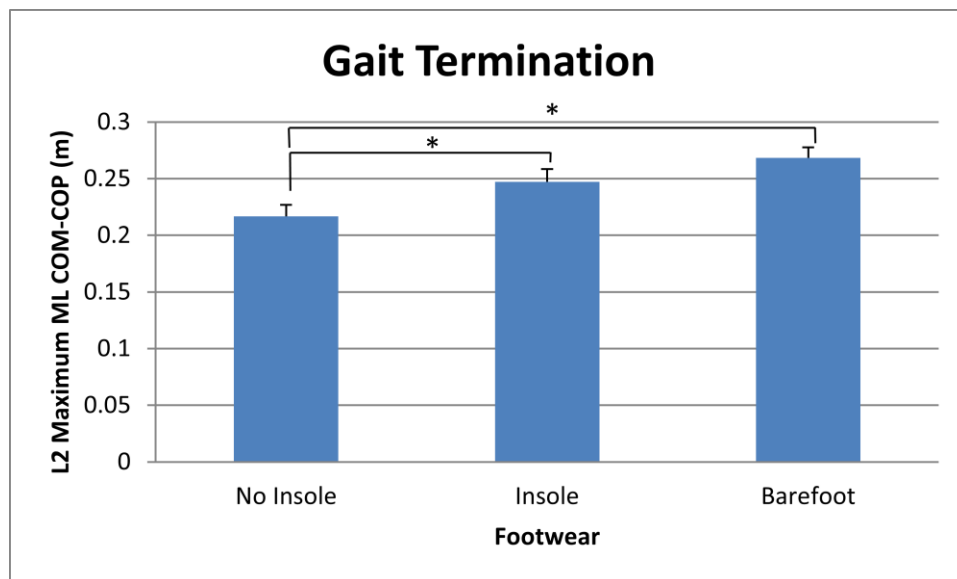

Figure 10: Maximum ML COM-COP comparisons for L2 stance between footwear conditions of GT. (* significant differences ($p<0.05$), standard error bars) (See Appendix H, Table 3)

In contrast, minimum ML COM-COP differences for the L2 stance were also compared during GT. Similar to values displayed for the maximum values of COM-COP differences, minimum differences were greatest during the barefoot (0.12 m) condition and lower during the insole (<0.12 m) and no insole (0.07 m) conditions. Significant differences ($F_{22,77}=7.41$, $p<0.0001$; $es=0.68$) for these minimum differences were also parallel to the COM-COP maximum values such that the minimum COM-COP difference was significantly smaller during the no insole condition as compared to the insole and barefoot conditions.

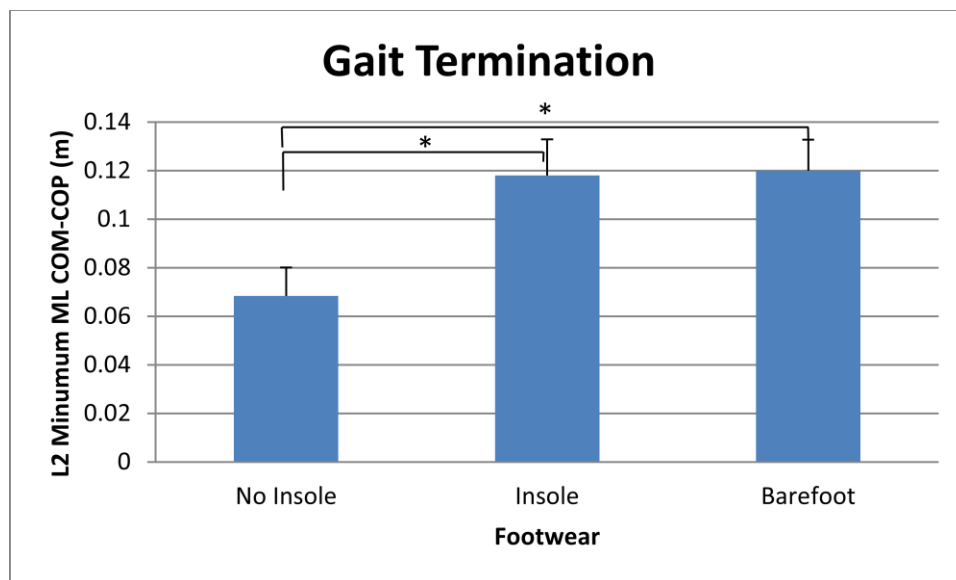

Figure 11: Minimum ML COM-COP comparisons for L2 stance between footwear conditions of GT. (* significant differences ($p<0.05$), standard error bars) (See Appendix H, Table 4)

Vertical Force Rate of Loading (ROL)

During the L2 stance of GT, vertical force loading rates were greatest during the insole (593.6 N/s) condition. These rates decreased as participants terminated gait during the no insole (544.4 N/s) and were least during the barefoot (530.8 N/s) condition. No significant differences were identified for vertical force loading rates between all footwear conditions.

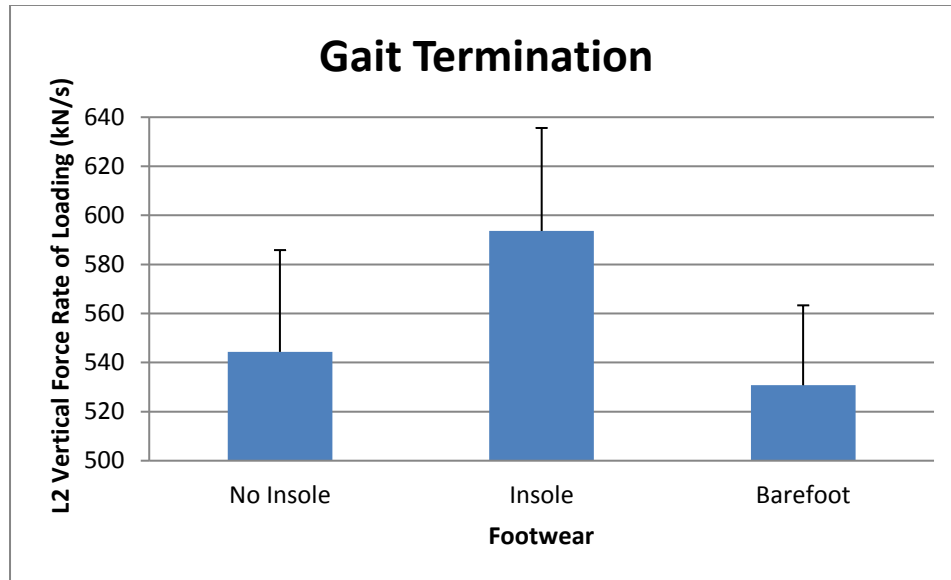

Figure 12: Vertical force loading rate comparisons for L2 stance between footwear conditions of GT. (* significant differences ($p < 0.05$), standard error bars) (See Appendix H, Table 5)

As participants advanced to the third right (R3) stance of GT, vertical force loading rates for all three footwear conditions displayed different results as compared to these values during the L2 stance. During the final stance of GT (R3), vertical force loading rates were least during the insole (189.7 N/s) condition. Barefoot (292.5 N/s) and no insole (317.2 N/s) conditions in turn produced values greater than the insole condition. Vertical force loading rates were identified to be significantly lower ($F_{23,105}=4.34$, $p < 0.0001$; $es=0.49$) during the insole condition as compared to both no insole and barefoot conditions.

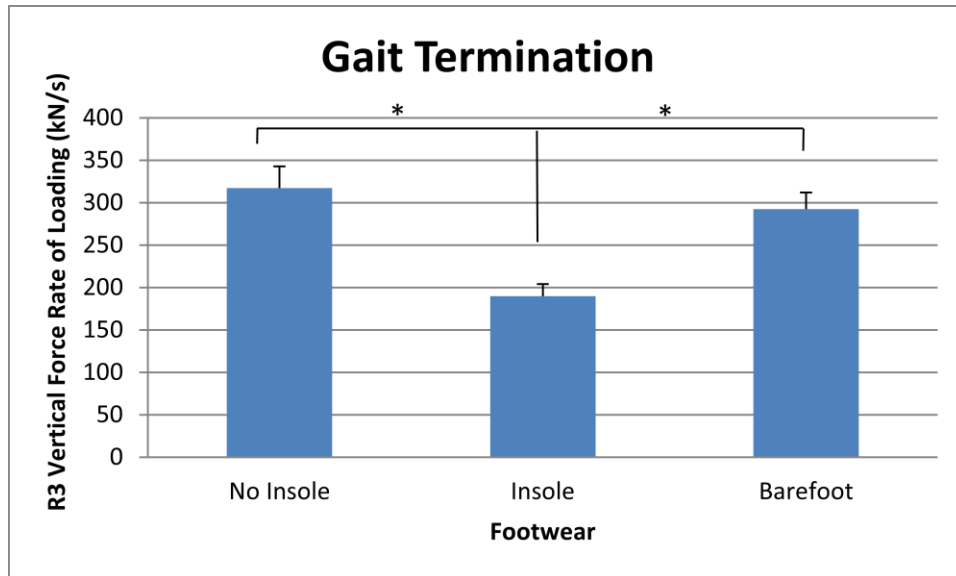

Figure 13: Vertical force loading rate comparisons for R3 stance between footwear conditions of GT. (* significant differences ($p < 0.05$), standard error bars) (See Appendix H, Table 6)

Step Width

As participants advanced to the L2 step during GT, step widths were widest during the no insole condition (0.10 m) with insole (0.09 m) and barefoot (0.07 m) conditions displaying progressively narrower step widths. Significant differences ($F_{21,72} = 5.36$, $p < 0.0001$; $es = 0.61$) in step width were presented between no insole and barefoot conditions.

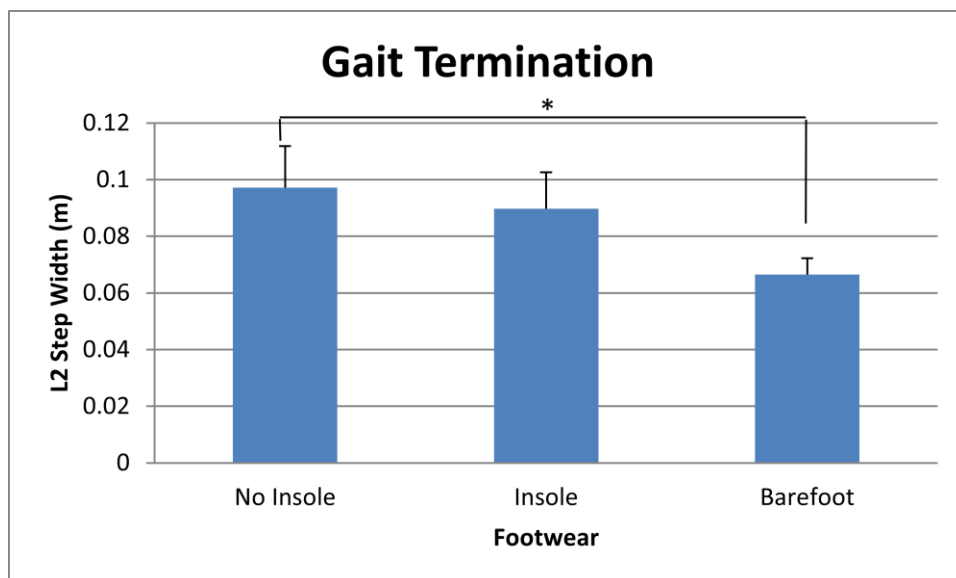

Figure 14: Step width comparisons for L2 step between footwear conditions of GT. (* significant differences ($p < 0.05$), standard error bars) (See Appendix H, Table 7)

Step widths during the R3 (final) step during GT were widest during barefoot (>0.11 m) trials and were progressively narrower during no insole (0.11 m) and insole (<0.11 m) conditions. Differences displayed in these step widths were small and not significant.

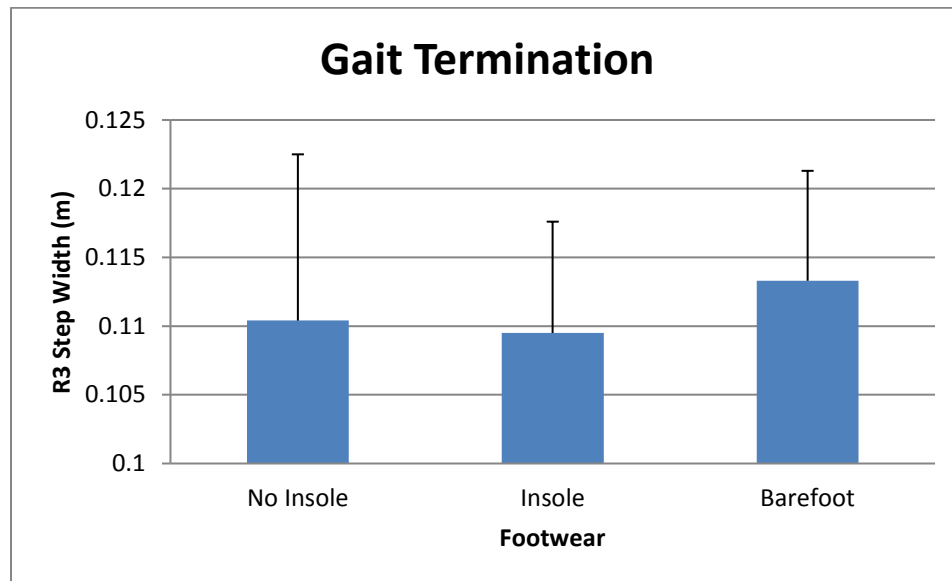

Figure 15: Step width comparisons for R3 step between footwear conditions of GT. (* significant differences ($p < 0.05$), standard error bars) (See Appendix H, Table 8)

Step Length

Step lengths during the L2 step varied between footwear conditions during GT. The shortest steps occurred during the insole (0.48 m) condition, increasing in length with barefoot (0.54 m) and no insole (0.56 m) conditions. Significant differences were only found between insole and no insole conditions ($F_{21,72}=4.26$, $p < 0.0001$; $es=0.55$).

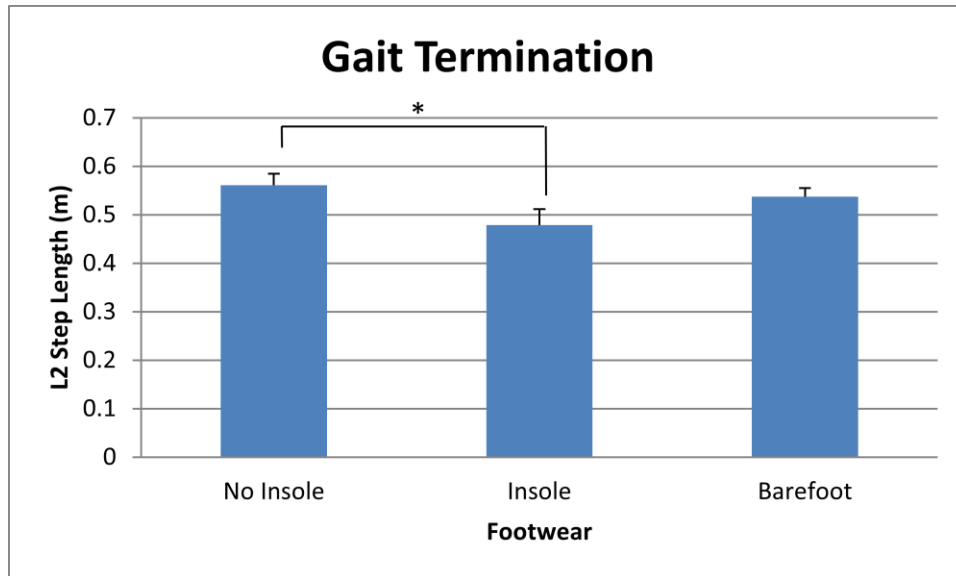

Figure 16: Step length comparisons for L2 step between footwear conditions of GT. (* significant differences ($p < 0.05$), standard error bars) (See Appendix H, Table 9)

As participants took their next step to terminate gait (R3 step), steps lengths remained longest while not wearing the test insole (0.27 m). However, in the other footwear conditions, barefoot (0.18 m) displayed the shortest steps with the insole (0.19 m) condition showing similarly short step lengths. Significant difference ($F_{22,90}=4.67$, $p < 0.0001$; $es=0.53$) were found between the no insole condition and both the insole and barefoot conditions, separately.

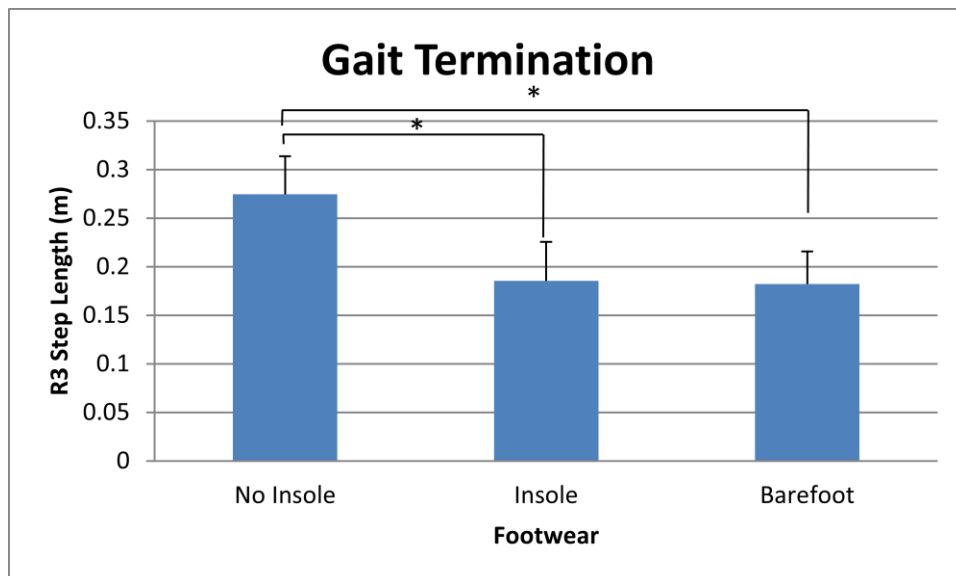

Figure 17: Step length comparisons for R3 step between footwear conditions of GT. (* significant differences ($p < 0.05$), standard error bars) (See Appendix H, Table 10)

Velocity Difference

Change in average gait velocity differences between the second right (R2; audio cue stance) and L2 (initial stance following audio cue) stances were examined and compared during GT. Participants produced the largest change in gait velocity during barefoot (0.42 m/s) trials and the smallest change while not wearing the test insoles (0.27 m/s). Mid-range changes in average gait velocity were observed during the insole (0.35 m/s) condition. Significant differences ($F_{23,105}=3.28$, $p<0.0001$; $es=0.42$) were determined between the no insole and barefoot conditions such that there was a significantly greater change in average gait velocity during the barefoot condition than the no insole condition. However, the insole condition did not display statistically significant differences in comparison to no insole and barefoot conditions.

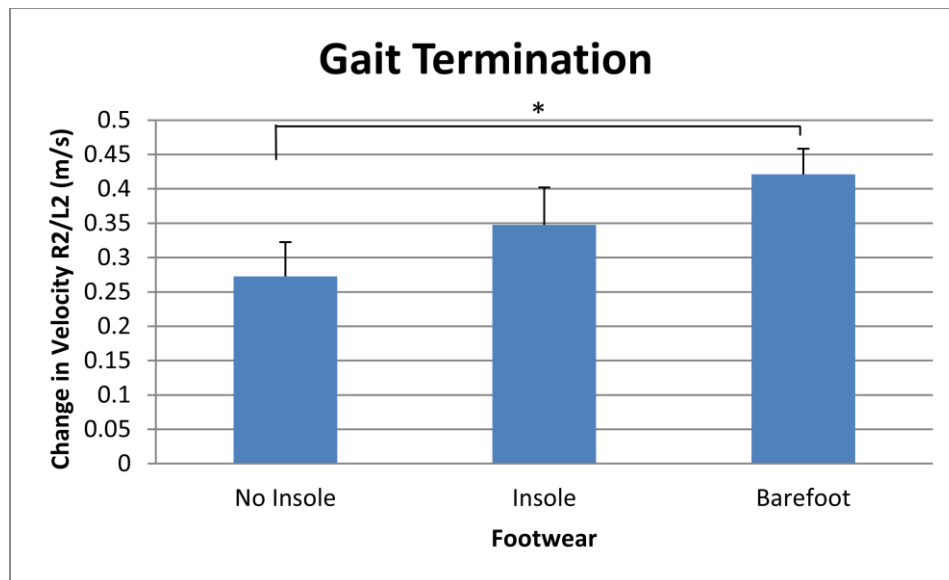

Figure 18: Change in velocity comparisons between R2 and L2 stances between footwear conditions for GT. (* significant differences ($p<0.05$), standard error bars) (See Appendix H, Table 11)

Normal Walking

ML COM-COP

Maximum ML COM-COP differences for the R3 stance varied between footwear conditions during normal walking (NW). Barefoot (0.17 m) conditions displayed the largest

difference in this variable and were smallest during the insole (0.16 m) condition. The no insole (<0.17 m) condition displayed similar values to barefoot and insole conditions. However, none of these differences were significant.

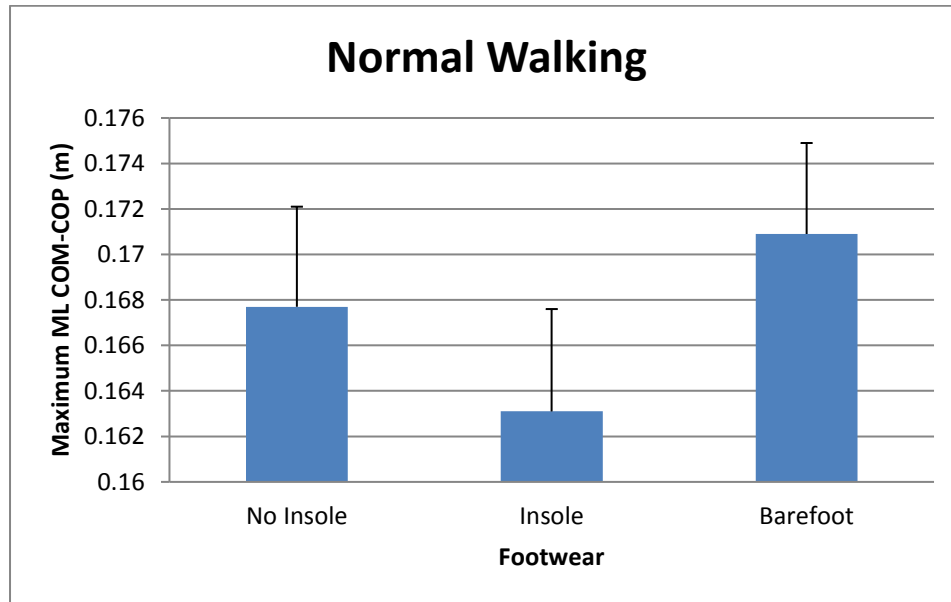

Figure 19: Maximum ML COM-COP comparisons for R3 stance between footwear conditions of NW. (* significant differences ($p < 0.05$), standard error bars) (See Appendix H, Table 12)

Minimum ML COM-COP differences during the R3 stance during NW displayed different results than the equivalent maximum variable values. Minimum differences for this COM-COP comparison were largest during the insole (0.06 m) condition and smallest during the no insole (<0.05 m) condition. Values for this difference for the barefoot (<0.05 m) condition were slightly larger than those of the no insole condition. Of these values for the various footwear conditions, the minimum ML COM-COP difference was significantly larger ($F_{25,249} = 10.58$, $p < 0.0001$; $es = 0.52$) during the insole condition as compared to both the no insole and barefoot conditions during NW.

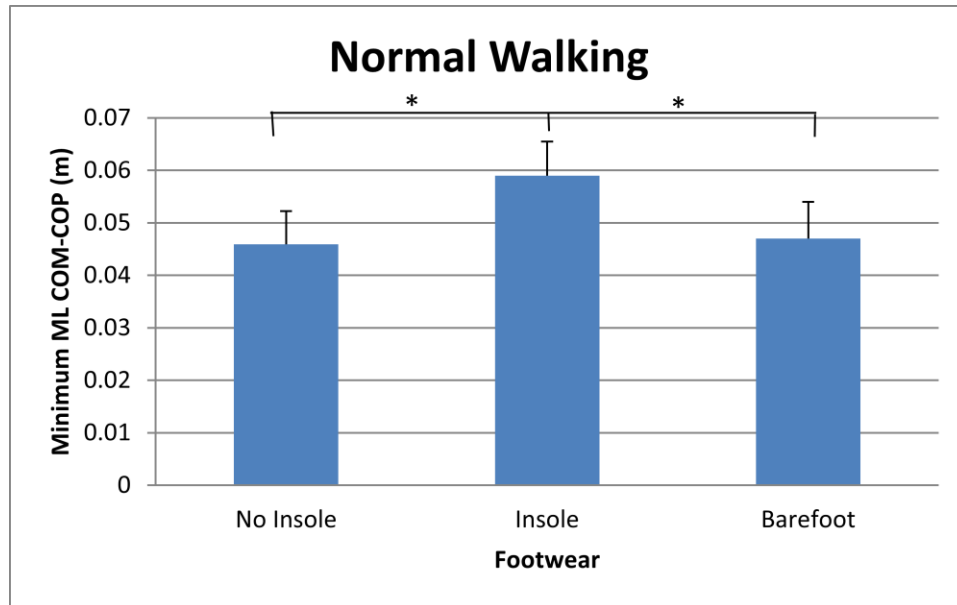

Figure 20: Minimum ML COM-COP comparisons for R3 stance between footwear conditions of NW. (* significant differences ($p < 0.05$), standard error bars) (See Appendix H, Table 13)

Vertical Force ROL

Vertical force loading rates were the lowest during the insole (351.2 N/s) condition of the R3 stance during NW. Barefoot (356.2 N/s) and no insole (357.6 N/s) conditions displayed loading rates greater than those within the insole condition, but no footwear conditions were significantly different than one another.

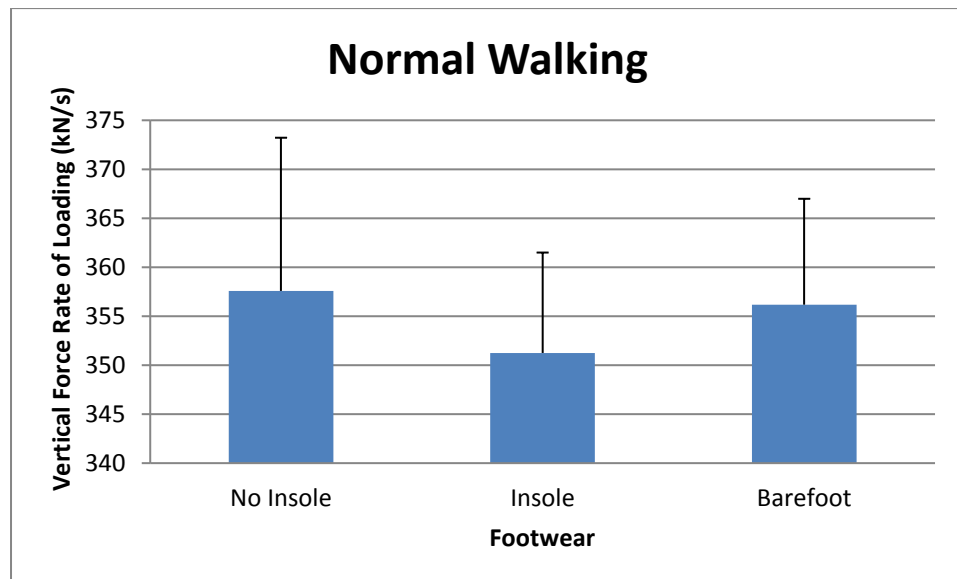

Figure 21: Vertical force loading rate comparisons for R3 stance between footwear conditions of NW. (* significant differences ($p < 0.05$), standard error bars) (See Appendix H, Table 14)

Step Width

As participants preceded to walk up the inclined walkway during NW, step widths during the R3 step were greatest during the no insole (0.08 m) condition and decreased as participants completed insole (0.07 m) and barefoot (0.07 m) conditions. These differences in step width between footwear conditions were not significant.

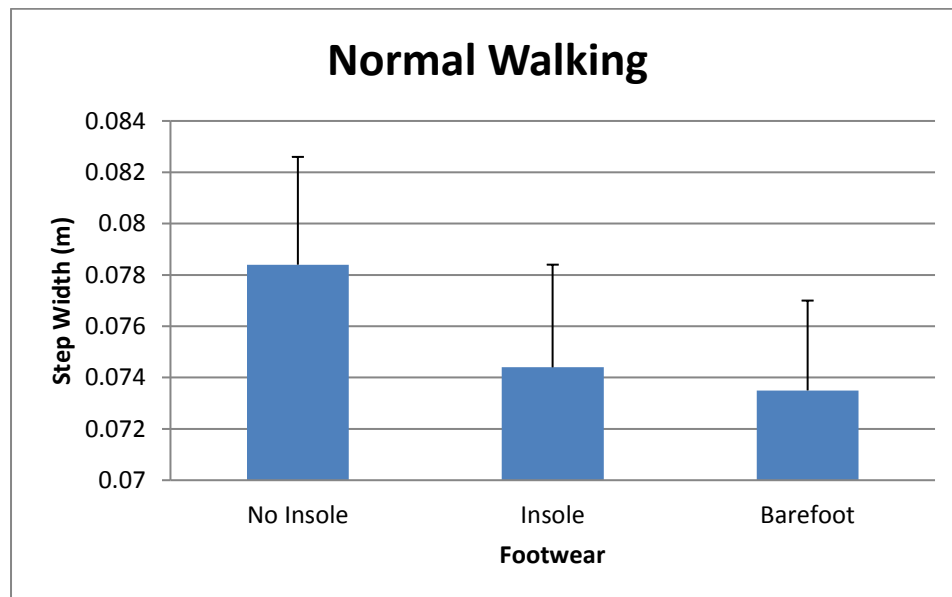

Figure 22: Step width comparisons for R3 step between footwear conditions of NW. (* significant differences ($p < 0.05$), standard error bars) (See Appendix H, Table 15)

Step Length

Step lengths for NW during all footwear conditions varied. Lengths during the barefoot (0.56 m) condition were the shortest as compared to greater lengths during the insole (0.61 m) and no insole (0.62 m) conditions. There was no significant difference between the insole and no insole footwear conditions, but the barefoot condition displayed step lengths that were significantly ($F_{25,305} = 17.08$, $p < 0.0001$; $es = 0.58$) shorter than the no insole and insole conditions.

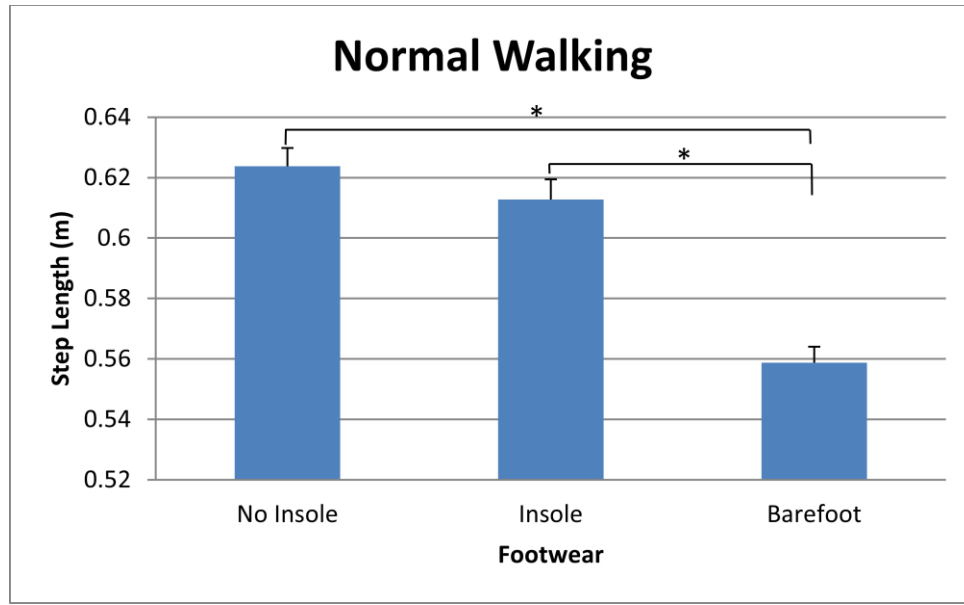

Figure 23: Step length comparisons for R3 step between footwear conditions of NW. (* significant differences ($p < 0.05$), standard error bars) (See Appendix H, Table 16)

Cognitive Walking

ML COM-COP

Maximum ML COM-COP comparisons for the R3 stance were also calculated during cognitive walking (CW). Values for this difference were lowest during the insole (< 0.16 m) condition, increasing in value as participants completed barefoot (< 0.17 m) and no insole (> 0.17 m) conditions. However, these differences were not significant.

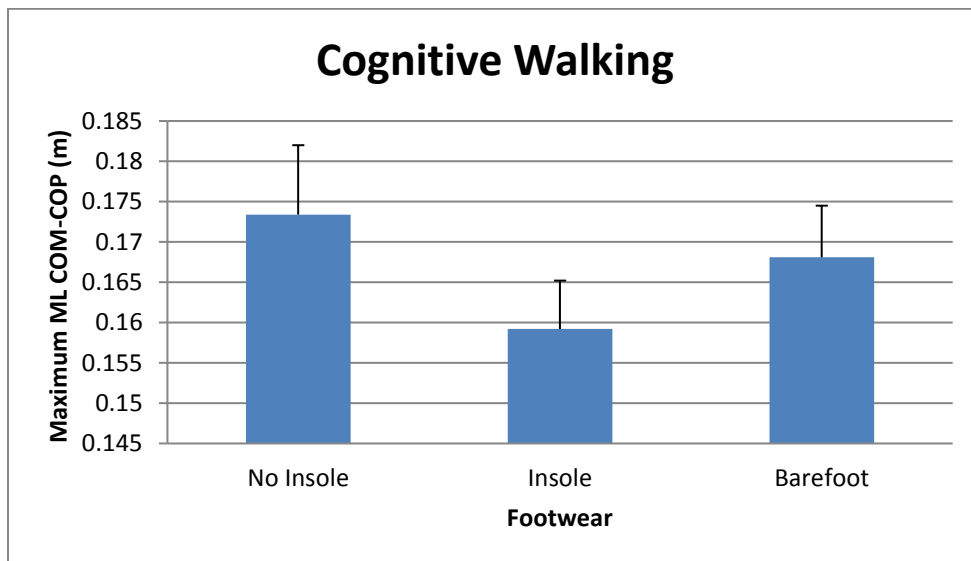

Figure 24: Maximum ML COM-COP comparisons for R3 stance between footwear conditions of CW. (* significant differences ($p < 0.05$), standard error bars) (See Appendix H, Table 17)

Minimum ML COM-COP comparisons for the R3 stance during CW were greatest during the no insole (>0.05 m) condition and least during the barefoot (0.04 m) condition. These minimum values for the insole (<0.05 m) condition were between those of the no insole and barefoot conditions. Much like results determined for the maximum ML COM-COP values, no significant differences were found for the R3 stance during CW.

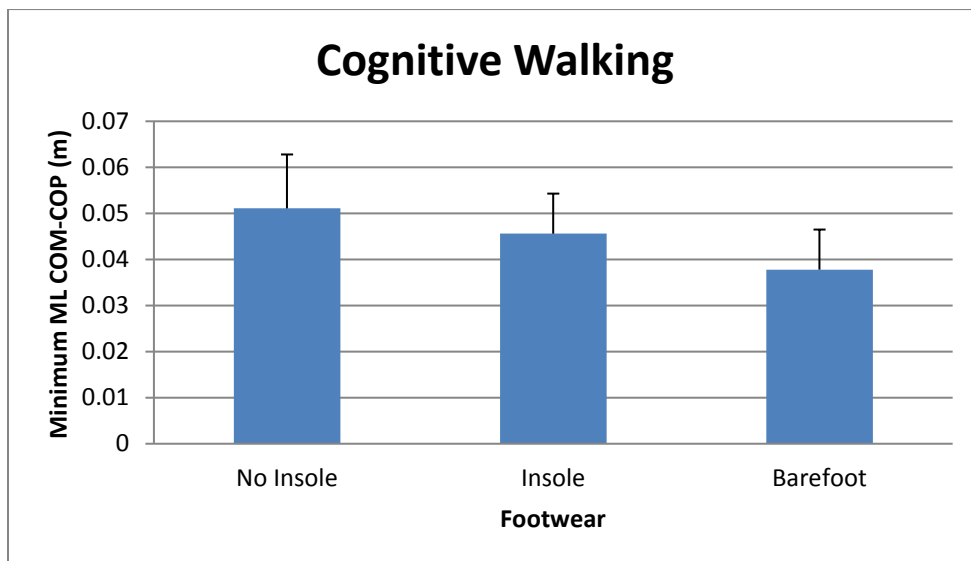

Figure 25: Minimum ML COM-COP comparisons for R3 stance between footwear conditions of CW. (* significant differences ($p < 0.05$), standard error bars) (See Appendix H, Table 18)

Vertical Force ROL

During CW along the inclined walkway, participants displayed the largest vertical force loading rates within the barefoot (349.7 N/s) condition and the smallest loading rates while not wearing the test insole (315.8 N/s) during the R3 stance. While wearing the test insole (333.9 N/s), participants produced loading rates between those of the no insole and barefoot conditions. Only the barefoot condition values were significantly ($F_{26,150}=6.90$, $p < 0.0001$; $es=0.54$) larger than rates produced within the no insole condition. No other significant differences were found for vertical loading rates during CW.

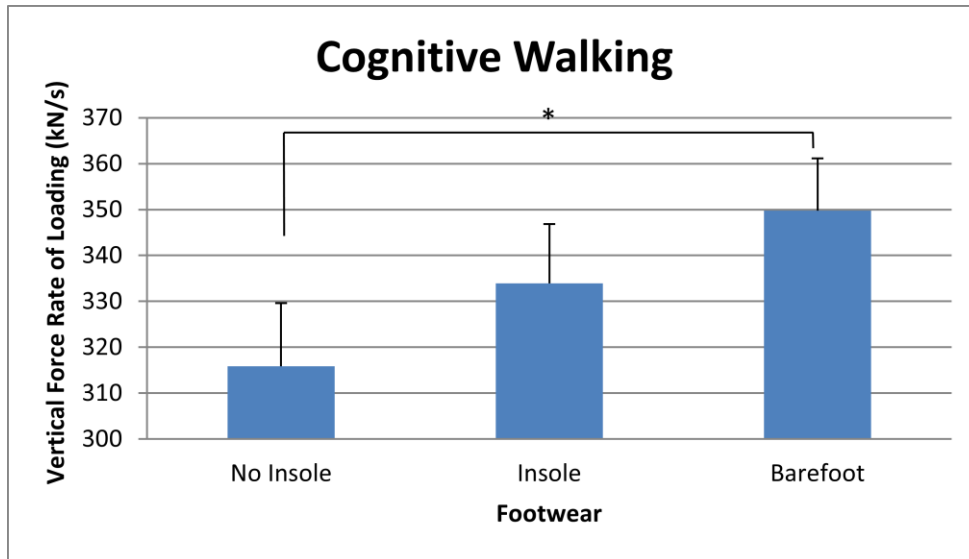

Figure 26: Vertical force loading rate comparisons for R3 stance between footwear conditions of CW. (* significant differences ($p < 0.05$), standard error bars) (See Appendix H, Table 19)

Step Width

Step widths during CW varied between footwear conditions for the R3 step. Widths were the most narrow during the barefoot (< 0.07 m) condition and the widest during the insole (> 0.07 m). Values of step width for the no insole (< 0.07 m) condition were between those of the insole and barefoot conditions. However, none of these differences were significant.

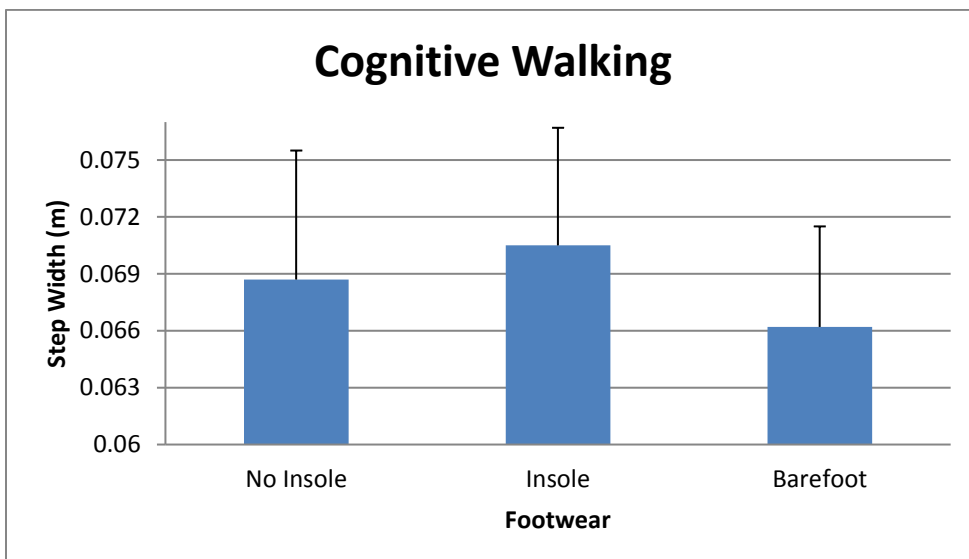

Figure 27: Step width comparisons for R3 step between footwear conditions of CW. (* significant differences ($p < 0.05$), standard error bars) (See Appendix H, Table 20)

Step Length

Step lengths of the R3 step during CW were the shortest during the barefoot (0.56 m) condition. Contrastingly, the longest steps were observed during the insole (0.60 m) condition. Finally, step lengths during the no insole (0.58 m) condition were shorter than those in the insole condition, but longer than those produced within the barefoot condition. Of these values between conditions, step lengths of the R3 step were significantly ($F_{23,110}=10.97$, $p<0.0001$; $es=0.70$) shorter in the barefoot condition as compared to both the no insole and insole conditions.

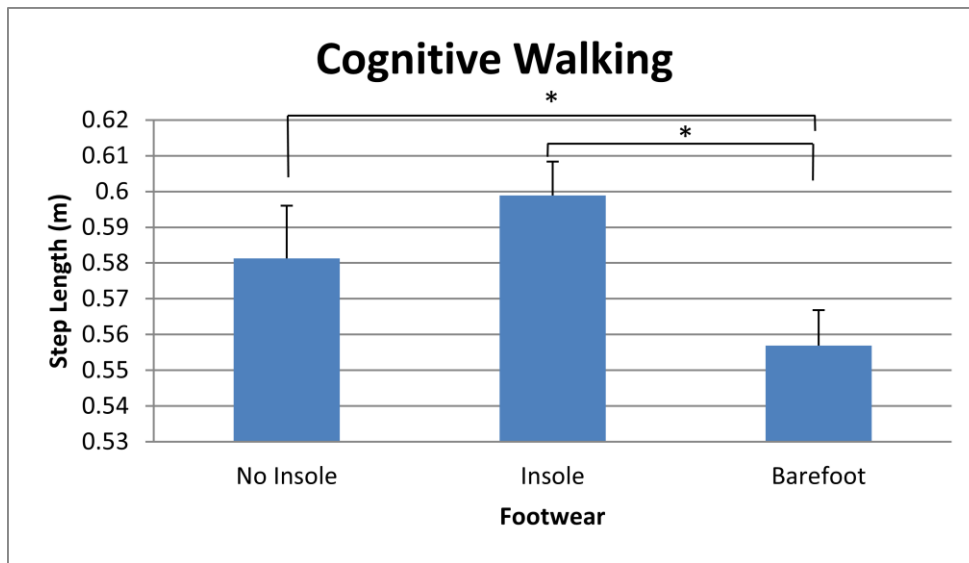

Figure 28: Step length comparisons for R3 step between footwear conditions of CW. (* significant differences ($p<0.05$), standard error bars) (See Appendix H, Table 21)

Discussion

This study aimed to explore and confirm evidence of balance-enhancing affects of thin and hard insoles through an experimental environment with a single data collection session. The primary variables analyzed for this study were hypothesized to show that balance would improve while wearing the test insoles when compared to no insole and barefoot conditions for all inclined walking conditions including normal walking (NW), gait termination (GT), and cognitive walking (CW). The test insoles were hypothesized to increase balance through increased somatosensory feedback on the sole of the foot and improved mechanical advantage.

Gait Termination

Medial/lateral (ML) center of mass - center of pressure (COM-COP) maximum and minimum values during GT produced similar trends such that the barefoot conditions produced the largest differences, decreasing in measurement within the insole and no insole conditions, sequentially. Within both variables, barefoot conditions produced significantly greater differences in ML COM-COP measurements during GT as compared to insole and no insole footwear conditions. Considering the ML COM-COP maximum was larger in the hard insole and barefoot conditions, this could potentially indicate that with a hard insole and no footwear the individual could extend their reactive force (represented by the COP) farther to provide a much more substantial slowing of the velocity of gait (or to help control the COM movement) in response to the audio cue. This implication is supported as Perry et al. (2007) demonstrated similar findings for the COM-COP difference for hard insole and barefoot conditions during unexpected GT.

During the insole condition, participants produced a significantly lower vertical force rate of loading (ROL) during the third right (R3) stance comparison to no insole and barefoot conditions. Reasons that may explain this trend include participants' efficiency in decreasing their velocity during single support of the second left (L2) stance. Although not significant, a higher ROL in the L2 stance prior to terminating gait may have led to a lower ROL required to complete termination of gait during the R3 stance, or the final step of termination. This decrease in ROL during the insole condition could have indicated that participants were more stable while wearing the insoles during unexpected GT.

During the barefoot condition of GT, participants produced a narrower step width as compared to both insole and no insole conditions, but only significantly narrower than the no insole condition during the L2 step. Although not significant, the insole condition also displayed a narrower step width during the R3 step as compared to the no insole condition. These results could have been a possible indicator that wearing harder insoles further increased stability by not requiring a wider base of support (BOS) prior to complete termination of gait.

Step lengths during GT were longest during the no insole condition for both the L2 and R3 steps. This could imply that participants required a larger BOS to maintain stability prior to GT while not wearing the test insoles. Step lengths of the L2 and R3 steps were significantly longer than those produced in the insole condition, but only significantly longer than the barefoot condition for the R3 step. Considering the L2 and R3 steps lengths simultaneously, the decreased step length required prior to final GT could imply that participants did not need to generate a large BOS to maintain stability following an audio cue perturbation.

Differences in average gait velocity between the second right (R2) and L2 stances were highest during the barefoot condition and lowest in the no insole condition. These conditions

were determined to be significantly different in change in velocity from one another, but the insole condition only produced velocity change values between the no insole and barefoot conditions. Contrary to the hypothesis, the insole condition did not produce the largest change in average gait velocity between these two single stance phases. However, although this condition was not the highest or significant, participants did produce a larger change in their average gait velocity than when the participants that did not wear the test insole. Since the barefoot condition would have provided the participant with the most somatosensory feedback on the sole of their foot, it would be logical that they could detect a change in COM movement more quickly and, therefore, able to decrease their average gait velocity accordingly to prepare for termination of gait (Perry, 2000; Perry, Santos, & Patla, 2001). This trend in possible increased stability during the insole condition during GT, if more participants were included in the study to increase the power level, this difference could have been significant.

Normal Walking

Measurements for ML COM-COP maximum values were similar across footwear conditions such that no significant findings resulted. However, the insole condition did display the lowest maximum values during NW. Minimum ML COM-COP values were, however, significantly different between footwear conditions. Minimum values within the insole condition were significantly greater than both the no insole and barefoot values. A combination of the significant minimum results and the trending low maximum results for the insole condition during NW, implications could be made such that the insole permitted the individual to walk within a tighter range and keep the difference in ML COM-COP more constant throughout the gait cycle.

In accordance with the previous hypothesis, step widths were widest for the R3 step during the no insole condition as compared to the insole and barefoot conditions during NW. However, even though these differences occurred, they were not significant. Studies determined that step width variability is substantial in OA gait in general (Maki, 1997; Owings & Grabiner, 2004), but may also contribute to falls risk (Brach, Berlin, VanSwearingen, Newman, & Studenski, 2005; Maki, 1997). Therefore, this trend in decreasing step widths with increasing somatosensory feedback between footwear conditions could indicate that participants required a larger BOS to maintain stability during the no insole condition. Step widths of the R3 step for the insole condition displayed measurements closer to the barefoot condition, implying that somatosensory feedback could in fact have been increased while wearing a harder insole.

Similar to step widths of the R3 step during NW, a similar trend was displayed for R3 step lengths. However, R3 step lengths of the barefoot condition as compared to both the no insole and insole conditions were significantly shorter. This is contrary to the hypothesis of this study such that stability was originally defined to be characteristic of long steps as opposed to short, shuffle patterned steps. Previous work has demonstrated that step length variability may not be the best predictor of falls risk (Brach et al., 2005; Owings & Grabiner, 2004). However, when compared to R3 step widths, since the no insole condition produced the widest and longest steps, this may be indicative of an attempt to produce a larger BOS. When in combination, the R3 step widths and lengths for the insole condition during NW may imply that participants were the most stable due to the narrow and long BOS produced from this stepping pattern. The hard insole may have provided enough somatosensory feedback such that OA did not require such a stable stance due to the confident detection of COM movement. This would be especially

probable considering the R3 step lengths between the no insole and insole condition for NW were not significantly different.

Cognitive Walking

Maximum and minimum ML COM-COP differences were all similar and not significantly different between footwear conditions within each variable. This may indicate that, independent of footwear, individuals walked with an unvarying gait pattern due to the cognitive demand (Rogers, 2003).

Step widths for the R3 step displayed similar measurements between footwear conditions. None of the conditions produced step widths that were significantly different from one another during CW. Analysis of step widths alone does not imply stability was significantly altered between footwear conditions, although some research implies that step width variability is a good predictor of fall risk (Maki, 1997; Owings & Grabiner, 2004). However, a small trend seems to be occurring such that the insole condition produced the widest R3 step widths.

In contrast, R3 step lengths during CW were parallel to this study's hypothesis. Insole and no insole conditions produced significantly longer steps as compared to the barefoot condition, with the longest steps occurring during the insole condition. Once again, the insole and no insole conditions were not significantly different, but when in combination with the corresponding R3 step widths, the BOS produced within the no insole condition were larger in surface area than those produced in the insole condition during CW. Although not significant, if more participants were included in this study, these trends may have been significant, thus, further implying that stability was greatest during the insole condition.

Summary

Overall balance and stability seemed to improve during the hard insole walking conditions. During GT, the ML COM-COP measurements displayed that participants may have been efficient in extending their COP (reactive forces) that controlled the COM back into a stable position (thus decreasing their gait velocity) in the preparation to terminate gait while wearing the hard insoles. This relationship between the COM-COP is supported as there was a significant decrease in average gait velocity during the step between the stance at which the audio cue was signalled for GT and the second last stance prior to termination of gait during the insole condition. This implies that participants were efficient in slowing their gait velocity prior to terminating gait which is further supported through lower rates of loading during the final stance of GT. Participants were stable enough to allow them to produce a softer foot loading during the final stance of GT, increasing overall balance and stability while wearing the hard insoles. During NW, the hard insoles may have permitted participants to walk within a tighter range by keeping the ML COM-COP difference constant throughout the gait cycle. During CW, mixed results were produced as this may be attributed to the cognitive task distraction. Participants may have produced a more restrictive gait pattern within all footwear conditions due to the diverted focus on performing the cognitive task; thus, no significant findings were found regarding balance and stability. Major findings for balance-enhancing effects of the hard insoles in combination with hard midsole material was observed within GT walking trials.

Conclusion

In conclusion, a hard midsole in combination with a hard insole may contribute to improved overall dynamic balance control. Somatosensory feedback on the sole of the foot may

have been increased from the hard surface of the insole to avoid insulating pressure sensing cutaneous mechanoreceptors. A mechanical advantage may also have been present as the insole hardness level did not allow substantial depression of the insole material. Further research is warranted to verify these findings and to determine if the balance effects of hard midsole and insoles are present over time through a footwear intervention.

Limitations

Recruitment of OA participants was the most significant limitation within this research study. Most OA that were interested in the project had either a neurological or physical condition that affected their balance or they were in use of some form of foot support (including orthotics) for foot pain. Initially, this study was meant to recruit OA for a 12 week intervention wearing the same footwear with the test insoles at least 8 hours per day, every day for 12 weeks. Most OA were not willing to wearing the same footwear for this length of time. In relation to this intervention, seasonal weather limitations also arose because the study was conducted during the summer months. Volunteers often defended their rejection to participate because they thought their walking shoes would be too hot on days of high temperatures. Instead, some OA stated they preferred to wear sandals throughout the summer months, making them ineligible for the study. Due to low participant recruitment, this in turn lowered the power of this research study, possibly affecting significant trends of data and presenting non significant trends that may have been significant if more participants were involved in the study.

Of those who participated in the study for the intervention, footwear chosen for each participant throughout the 12 week intervention was a limitation. Ideally, each participant would have worn the same manufactured footwear with sizes according to their foot sizes. However,

this was not feasible for multiple reasons. Each individual has specific foot characteristics; thus, not every OA may have been able to wear a specific model of footwear. Esthetically, each participant may have not been willing to wear a certain fashion of footwear for the entire duration of the intervention. This may have been true if OA tended to wear certain footwear for special events such as social, formal or active events. Cost efficiency would have also been sacrificed if the same footwear was purchased for each participant by the primary investigator in addition to the test insoles. On the contrary, variables collected may have been affected by the footwear selected for each participant. Although, each set of footwear was examined to be within a range of material measurements as advised by previous literature (Hatton et al., 2013; Menant, J. C., Steele, J. R., et al., 2008; Menz & Sherrington, 2000), there may have been differences between footwear materials that could have affected gait and subsequent balance and stability traits.

The use of pressure sensor insoles to collect force data may have also been a limitation. There was a great benefit of being able to insert the pressure insole into various footwear, but pressure sensor insoles are incapable of measuring shear forces and are not as accurate as compared to a force platform embedded into the ground.

An additional limitation could have included estimating COM locations with the 11-marker model set-up. This analysis process is only an estimate of the physical properties of each individual. Markers may have not been placed on the same location for each participant and may have moved during data collection due to the fixation of the markers on to moving clothing. Therefore, COM measurements may not have been exact representations of individual physical characteristics.

Future Research

Further research is warranted to investigate the effects of these test insoles and hard midsole material with a larger sample size. This would better represent the OA population's stability. Comparing the results of this thesis project with data from a control group including young female adults with highly functioning sensory systems would be beneficial to determine if changes in stability among the OA population is due to neurological sensory uptake or due to mechanical properties of the footwear. Interventions of longer durations involving the wear of these hard insoles in combination with a hard midsole material would determine long-term balance-enhancing effects.

Footwear perception of balance confidence utilizing the ABC scale should also be considered to measure during the data collection session while participants are wearing the insoles in combination with a hard midsole shoe. Balance confidence may differ between when participants are recruited for participation in the study and during and following their experience wearing the hard insoles.

Feasibility should also be considered when implementing recommended footwear and subsequent characteristics. Marketing, advertising, and education on footwear in relation to balance and stability and fall prevention should be explored to ensure that OA perceive the footwear to be beneficial and build efficacy to purchase and wear footwear of such recommendations.

References

- Antonio, P. J., & Perry, S. D. (2014). Quantifying stair gait stability in young and older adults, with modifications to insole hardness. *Gait Posture, 40*(3), 429-434. doi:10.1016/j.gaitpost.2014.05.009
- Appels, B. A., & Scherder, E. (2010). The diagnostic accuracy of dementia-screening instruments with an administration time of 10 to 45 minutes for use in secondary care: a systematic review. *Am J Alzheimers Dis Other Demen, 25*(4), 301-316. doi:10.1177/1533317510367485
- Borland, A., Martin, C. H., & Locke, J. (2013). Nurses' understandings of suitable footwear for older people. *Int J Health Care Qual Assur, 26*(7), 653-665. doi:10.1108/IJHCQA-05-2012-0050
- Brach, J. S., Berlin, J. E., VanSwearingen, J. M., Newman, A. B., & Studenski, S. A. (2005). Too much or too little step width variability is associated with a fall history in older persons who walk at or near normal gait speed. *J Neuroeng Rehabil, 2*, 21. doi:10.1186/1743-0003-2-21
- Brett, K. M., & Burt, C. W. (2001). Utilization of ambulatory medical care by women: United States, 1997-98. *Vital and Health Statistics. Series 13, Data from the National Health Survey, 13*(149), 1-46.
- Burns, S. L., Leese, G. P., & McMurdo, M. E. T. (2002). Older people and ill fitting shoes. *Postgraduate Medical Journal, 78*(920), 344-346. doi:10.1136/pmj.78.920.344
- Canada, S. (2012). Canadian community health survey - annual component (CCHS). *Ottawa: Statistics Canada.*
- Centers for Disease Control and Prevention, C. (2015). Injury prevention & control: Data and statistics (WISQARS).
- Chantelau, E., & Gede, A. (2002). Foot dimensions of elderly people with and without diabetes mellitus - a data basis for shoe design. *Gerontology, 48*(4), 241-244. doi:10.1159/000058357
- Davis, A., Murphy, A., & Haines, T. P. (2013). "Good for older ladies, not me": how elderly women choose their shoes. *Journal of the American Podiatric Medical Association, 103*(6), 465-470. doi:http://dx.doi.org/10.7547/1030465
- de Moraes Barbosa, C., Barros Bertolo, M., Marques Neto, J. F., Bellini Coimbra, I., Davitt, M., & de Paiva Magalhaes, E. (2013). The effect of foot orthoses on balance, foot pain and disability in elderly women with osteoporosis: a randomized clinical trial. *Rheumatology (Oxford), 52*(3), 515-522. doi:10.1093/rheumatology/kes300
- Donald, I. P., & Bulpitt, C. J. (1999). The prognosis of falls in elderly people living at home. *Age and Ageing, 28*(2), 121-125.
- Ferraro, R. A., Pinto-Zipp, G., Simpkins, S., & Clark, M. (2013). Effects of an inclined walking surface and balance abilities on spatiotemporal gait parameters of older adults. *J Geriatr Phys Ther, 36*(1), 31-38. doi:10.1519/JPT.0b013e3182510339
- Folstein, M. F., Folstein, S. E., & McHugh, P. R. (1975). "Mini-mental state": A practical method for grading the cognitive state of patients for the clinician. *Journal of Psychiatric Research, 12*(3), 189-198. doi:10.1016/0022-3956(75)90026-6
- Freitas, S., Simoes, M. R., Maroco, J., Alves, L., & Santana, I. (2012). Construct Validity of the Montreal Cognitive Assessment (MoCA). *J Int Neuropsychol Soc, 18*(2), 242-250. doi:10.1017/S1355617711001573

- Gross, M. T., Mercer, V. S., & Lin, F. C. (2012). Effects of foot orthoses on balance in older adults. *Journal of Orthopaedic & Sports Physical Therapy*, 42(7), 649-657. doi:10.2519/jospt.2012.3944
- Hatton, A. L., Dixon, J., Martin, D., & Rome, K. (2009). The effect of textured surfaces on postural stability and lower limb muscle activity. *J Electromyogr Kinesiol*, 19(5), 957-964. doi:10.1016/j.jelekin.2008.04.012
- Hatton, A. L., Dixon, J., Rome, K., Newton, J. L., & Martin, D. J. (2012). Altering gait by way of stimulation of the plantar surface of the foot: the immediate effect of wearing textured insoles in older fallers. *Journal of Foot and Ankle Research*, 5(Suppl 1), O21. doi:10.1186/1757-1146-5-s1-o21
- Hatton, A. L., Rome, K., Dixon, J., Martin, D. J., & McKeon, P. O. (2013). Footwear interventions: A review of their sensorimotor and mechanical effects on balance performance and gait in older adults. *Journal of the American Podiatric Medical Association*, 103(6), 516-533. doi:10.7547/1030516
- Horak, F. B., Nashner, L. M., & Diener, H. C. (1990). Postural strategies associated with somatosensory and vestibular loss. *Experimental Brain Research*, 82(1), 167-177.
- Horgan, N. F., Crehan, F., Bartlett, E., Keogan, F., O'Grady, A. M., Moore, A. R., . . . Curran, M. (2009). The effects of usual footwear on balance amongst elderly women attending a day hospital. *Age Ageing*, 38(1), 62-67. doi:10.1093/ageing/afn219
- Ikpeze, T. C., Omar, A., & Elfar, J. H. (2015). Evaluating Problems With Footwear in the Geriatric Population. *Geriatr Orthop Surg Rehabil*, 6(4), 338-340. doi:10.1177/2151458515608672
- Ismail, Z., Rajji, T. K., & Shulman, K. I. (2010). Brief cognitive screening instruments: an update. *Int J Geriatr Psychiatry*, 25(2), 111-120. doi:10.1002/gps.2306
- Jacova, C., Kertesz, A., Blair, M., Fisk, J. D., & Feldman, H. H. (2007). Neuropsychological testing and assessment for dementia. *Alzheimers Dement*, 3(4), 299-317. doi:10.1016/j.jalz.2007.07.011
- Kennedy, P. M., & Inglis, T. (2002). Distribution and behaviour of glabrous cutaneous receptors in the human foot sole. *Journal of Physiology*, 538(3), 995-1002. doi:10.1013/jphysiol.2001.013087
- Koepsell, T. D., Wolf, M. E., Buchner, D. M., Kukull, W. A., LaCroix, A. Z., Tencer, A. F., . . . Larson, E. B. (2004). Footwear style and risk of falls in older adults. *Journal of the American Geriatrics Society*, 52(9), 1495-1501. doi:10.1111/j.1532-5415.2004.52412.x
- Leroux, A., Fung, J., & Barbeau, H. (2002). Postural adaptation to walking on inclined surfaces: I. Normal strategies. *Gait and Posture*, 15(1), 64-74. doi:http://dx.doi.org/10.1016/S0966-6362(01)00181-3
- Lindemann, U., Scheible, S., Sturm, E., Eichner, B., Ring, C., Najafi, B., . . . Becker, C. (2003). Elevated heels and adaptation to new shoes in frail elderly women. *Z Gerontol Geriatr*, 36(1), 29-34. doi:10.1007/s00391-003-0133-x
- Lindenberger, U., Marsiske, M., & Baltes, P. B. (2000). Memorizing while walking: increase in dual-task costs from young adulthood to old age. *Psychology and Aging*, 15(3), 417-436. doi:http://dx.doi.org/10.1037/0882-7974.15.3.417
- Lonie, J. A., Tierney, K. M., & Ebmeier, K. P. (2009). Screening for mild cognitive impairment: a systematic review. *Int J Geriatr Psychiatry*, 24(9), 902-915. doi:10.1002/gps.2208
- Lord, S. R., & Bashford, G. M. (1996). Shoe characteristics and balance in older women. *Journal of American Geriatrics Society*, 44(4), 429-433. doi:10.1111/j.1532-5415.1996.tb06416.x

- Lord, S. R., Bashford, G. M., Howland, A., & Munroe, B. J. (1999). Effects of shoe collar height and sole hardness on balance in older women. *Journal of the American Geriatrics Society*, 47(6), 681-684. doi:http://dx.doi.org/10.1111/j.1532-5415.1999.tb01589.x
- Losa Iglesias, M. E., Becerro de Bengoa Vallejo, R., & Palacios Pena, D. (2012). Impact of soft and hard insole density on postural stability in older adults. *Geriatr Nurs*, 33(4), 264-271. doi:10.1016/j.gerinurse.2012.01.007
- Lugade, V., Lin, V., & Chou, L. S. (2011). Center of mass and base of support interaction during gait. *Gait Posture*, 33(3), 406-411. doi:10.1016/j.gaitpost.2010.12.013
- Maki, B., Edmondstone, M. A., & McIlroy, W. E. (2000). Age-related differences in laterally directed compensatory stepping behavior. *Journal of Gerontology: Medical Sciences*, 55A(5), M270-M277. doi:10.1093/gerona/55.5.M270
- Maki, B., & McIlroy, W. (1996). Postural control in the older adult. *Clinics in Geriatric Medicine*, 12(4), 635-658.
- Maki, B. E. (1997). Gait changes in older adults: Predictors of falls or indicators of fear? *Journal of American Geriatrics Society*, 45(3), 313-320. doi:10.1111/j.1532-5415.1997.tb00946.x
- Massion, J. (1994). Postural control system. *Current Opinion in Neurobiology*, 4(6), 877-887. doi:10.1016/0959-4388(94)90137-6
- McIntosh, A. S., Beatty, K. T., Dwan, L. N., & Vickers, D. R. (2006). Gait dynamics on an inclined walkway. *J Biomech*, 39(13), 2491-2502. doi:10.1016/j.jbiomech.2005.07.025
- Menant, J. C., Perry, S. D., Steele, J. R., Menz, H. B., Munro, B. J., & Lord, S. R. (2008). Effects of shoe characteristics on dynamic stability when walking on even and uneven surfaces in young and older people. *Arch Phys Med Rehabil*, 89(10), 1970-1976. doi:10.1016/j.apmr.2008.02.031
- Menant, J. C., Steele, J. R., Menz, H. B., Munro, B. J., & Lord, S. R. (2008). Effects of footwear features on balance and stepping in older people. *Gerontology*, 54(1), 18-23. doi:10.1159/000115850
- Menant, J. C., Steele, J. R., Menz, H. B., Munro, B. J., & Lord, S. R. (2008). Optimizing footwear for older people at risk of falls. *The Journal of Rehabilitation Research and Development*, 45(8), 1167. doi:10.1682/jrrd.2007.10.0168
- Menz, H. B., & Lord, S. R. (1999). Footwear and postural stability in older people. *Journal of the American Podiatric Medical Association*, 89(7), 346-357. doi:doi:10.7547/87507315-89-7-346
- Menz, H. B., & Lord, S. R. (2005). Gait instability in older people with hallux valgus. *Foot and Ankle International*, 26(6), 483-489. doi:10.1177/107110070502600610
- Menz, H. B., & Morris, M. E. (2005). Footwear characteristics and foot problems in older people. *Gerontology*, 51(5), 346-351. doi:10.1159/000086373
- Menz, H. B., & Sherrington, C. (2000). The footwear assessment form: a reliable clinical tool to assess footwear characteristics of relevance to postural stability in older adults. *Clinical Rehabilitation*, 14(6), 657-664. doi:10.1191/0269215500cr375oa
- Mickle, K. J., Munro, B. J., Lord, S. R., Menz, H. B., & Steele, J. R. (2010). Foot pain, plantar pressures, and falls in older people: a prospective study. *J Am Geriatr Soc*, 58(10), 1936-1940. doi:10.1111/j.1532-5415.2010.03061.x
- Mickle, K. J., Munro, B. J., Lord, S. R., Menz, H. B., & Steele, J. R. (2010). Foot shape of older people: implications for shoe design. *Footwear Science*, 2(3), 131-139. doi:10.1080/19424280.2010.487053

- Miles, J., & Shevlin, M. (2001). *Applying regression and correlation: A guide for students and researchers*. London: SAGE Publications Ltd.
- Moghadam, M., Ashayeri, H., Salavati, M., Sarafzadeh, J., Taghipoor, K. D., Saeedi, A., & Salehi, R. (2011). Reliability of center of pressure measures of postural stability in healthy older adults: effects of postural task difficulty and cognitive load. *Gait Posture*, 33(4), 651-655. doi:10.1016/j.gaitpost.2011.02.016
- Mulford, D., Taggart, H. M., Nivens, A., & Payrie, C. (2008). Arch support use for improving balance and reducing pain in older adults. *Applied Nursing Research*, 21(3), 153-158. doi:10.1016/j.apnr.2006.08.006
- Munro, B. J., & Steele, J. R. (1999). Household-shoe wearing and purchasing habits. A survey of people aged 65 years and older. *Journal of the American Podiatric Medical Association*, 89(10), 506-514. doi:http://dx.doi.org/10.7547/87507315-89-10-506
- Owings, T. M., & Grabiner, M. D. (2004). Variability of step kinematics in young and older adults. *Gait and Posture*, 20(1), 26-29. doi:10.1016/S0966-6362(03)00088-2
- Pai, Y. C., Maki, B. E., Iqbal, K., McIlroy, W. E., & Perry, S. D. (2000). Thresholds for step initiation induced by support-surface translation: a dynamic center-of-mass model provides much better prediction than a static model. *Journal of Biomechanics*, 33(3), 387-392. doi:http://dx.doi.org/10.1016/S0021-9290(99)00199-2
- Palluel, E., Nougier, V., & Olivier, I. (2008). Do spike insoles enhance postural stability and plantar-surface cutaneous sensitivity in the elderly? *Age (Dordr)*, 30(1), 53-61. doi:10.1007/s11357-008-9047-2
- Palluel, E., Olivier, I., & Nougier, V. (2009). The lasting effects of spike insoles on postural control in the elderly. *Behav Neurosci*, 123(5), 1141-1147. doi:10.1037/a0017115
- Perry, S. D. (2000). *The role of plantar cutaneous mechanoreceptors in the control of compensatory stepping in the young and older adult*. Ph.D. Dissertation. University of Toronto.
- Perry, S. D. (2006). Evaluation of age-related plantar-surface insensitivity and onset age of advanced insensitivity in older adults using vibratory and touch sensation tests. *Neurosci Lett*, 392(1-2), 62-67. doi:10.1016/j.neulet.2005.08.060
- Perry, S. D., Radtke, A., & Goodwin, C. R. (2007). Influence of footwear midsole material hardness on dynamic balance control during unexpected gait termination. *Gait Posture*, 25(1), 94-98. doi:10.1016/j.gaitpost.2006.01.005
- Perry, S. D., Radtke, A., McIlroy, W. E., Fernie, G. R., & Maki, B. E. (2008). Efficacy and effectiveness of a balance-enhancing insole. *The Journals of Gerontology Series A: Biological Sciences and Medical Sciences*, 63(6), 595-602.
- Perry, S. D., Santos, L. C., & Patla, A. E. (2001). Contribution of vision and cutaneous sensation to the control of centre of mass (COM) during gait termination. *Brain Research*, 913(1), 27-34. doi:http://dx.doi.org/10.1016/S0006-8993(01)02748-2
- Priplata, A. A., Niemi, J. B., Harry, J. D., Lipsitz, L. A., & Collins, J. J. (2003). Vibrating insoles and balance control in elderly people. *The Lancet*, 362(9390), 1123-1124. doi:10.1016/s0140-6736(03)14470-4
- Qiu, F., Cole, M. H., Davids, K. W., Hennig, E. M., Silburn, P. A., Netscher, H., & Kerr, G. K. (2012). Enhanced somatosensory information decreases postural sway in older people. *Gait Posture*, 35(4), 630-635. doi:10.1016/j.gaitpost.2011.12.013
- Rankin, J. K., Woollacott, M. H., Shumway-Cook, A., & Brown, L. A. (2000). Cognitive influence on postural stability: A neuromuscular analysis in young and older adults. *The*

- Journals of Gerontology Series A: Biological Sciences and Medical Sciences*, 55(3), M112-M119. doi:10.1093/gerona/55.3.M112
- Robbins, S., Gouw, G. J., & McClaran, J. (1992). Shoe sole thickness and hardness influence balance in older men. *Journal of the American Geriatrics Society*, 40(11), 1089-1094.
- Rogers, N. L. (2003). *Cognitive influences of postural stability in the older adult*. Ph.D. Dissertation.
- Sherrington, C., & Menz, H. B. (2003). An evaluation of footwear worn at the time of fall-related hip fracture. *Age and Ageing*, 32(3), 310-314. doi:10.1093/ageing/32.3.310
- Sibley, K. M., Howe, T., Lamb, S. E., Lord, S. R., Maki, B. E., Rose, D. J., . . . Jaglal, S. B. (2015). Recommendations for a core outcome set for measuring standing balance in adult populations: a consensus-based approach. *PLoS One*, 10(3), e0120568. doi:10.1371/journal.pone.0120568
- Stephen, D. G., Wilcox, B. J., Niemi, J. B., Franz, J. R., Kerrigan, D., & D'Andrea, S. E. (2012). Baseline-dependent effect of noise-enhanced insoles on gait variability in healthy elderly walkers. *Gait Posture*, 36(3), 537-540. doi:10.1016/j.gaitpost.2012.05.014
- Tencer, A. F., Koepsell, T. D., Wolf, M. E., Frankenfeld, C. L., Buchner, D. M., Kukull, W. A., . . . Tautvydas, M. (2004). Biomechanical properties of shoes and risk of falls in older adults. *Journal of the American Geriatrics Society*, 52(11), 1840-1846. doi:10.1111/j.1532-5415.2004.52507.x
- Vass, C., Edwards, C., Smith, A., Sahota, O., & Drummond, A. (2015). What do patients wear on their feet? A service evaluation of footwear in elderly patients. *International Journal of Therapy and Rehabilitation*, 22(5), 21-28. doi:http://dx.doi.org/10.12968/ijtr.2015.22.5.225
- Vertesi, A., Lever, J. A., Molloy, D. W., Sanderson, B., Tuttle, I., Pokoradi, L., & Principi, E. (2001). Standardized mini-mental state examination. Use and interpretation. *Canadian Family Physician*, 47, 2018-2023.
- Waked, E., Robbins, S., & McClaran, J. (1997). The effect of footwear midsole hardness and thickness on proprioception and stability in older men. *Journal of Testing and Evaluation*, 25(1), 143-148. doi:10.1520/JTE11335J
- Wang, C. C., & Yang, W. H. (2012). Using detrended fluctuation analysis (DFA) to analyze whether vibratory insoles enhance balance stability for elderly fallers. *Arch Gerontol Geriatr*, 55(3), 673-676. doi:10.1016/j.archger.2011.11.008
- White, E. G., & Mulley, G. P. (1989). Footwear worn by the over 80's_a community survey. *Clinical Rehabilitation*, 3(1), 23-25. doi:10.1177/026921558900300104

Appendix A: Screening Questionnaire

SCREENING QUESTIONNAIRE

VOLUNTEER EXCLUSION CRITERIA

Date: (MM/DD/YYYY): ___/ ___/ _____

Name: _____

Address: _____

City, Province: _____, _____ Postal Code _____

Tel #: (____)-_____ Best time to call: _____

Age: ____ yrs. Height: _____ cm Weight: _____ kg

Gender: M __ F __

Are you left-handed? Yes No Both

Do you have any conditions that limit the use of your arms or legs? Yes / No

If yes, how much does the condition interfere with your activities?

little or none	moderate	a great deal
<input type="checkbox"/>	<input type="checkbox"/>	<input type="checkbox"/>

Describe: _____

Do you have or have you ever had:	Yes / No
a) paralysis	_____
b) epilepsy	_____
c) cerebral palsy	_____
d) multiple sclerosis	_____
e) Parkinson's disease	_____
f) stroke	_____
g) any other neurological disorder	_____
h) diabetes	_____
i) vision problem other than corrective glasses	_____
j) cataract surgery	_____
k) a balance or coordination problem	_____
l) an inner ear disorder	_____
m) hearing problems	_____
n) constant ringing in your ears	_____
o) ear surgery	_____

Have you ever had any serious problems with your memory? Yes / No

Do you have or ever had recurrent ear infections? Yes / No

Have you ever had frostbite in the lower extremities? Yes / No

How much do the conditions that you indicated with a 'yes' below interfere with your activities?

	Yes / No	little or none	moderate	a great deal
Do you have or have you ever had :				
a) problems with your heart or lungs	_____	<input type="checkbox"/>	<input type="checkbox"/>	<input type="checkbox"/>
b) high blood pressure	_____	<input type="checkbox"/>	<input type="checkbox"/>	<input type="checkbox"/>
blood circulation problems (generally)	_____	<input type="checkbox"/>	<input type="checkbox"/>	<input type="checkbox"/>
(specifically lower extremities)	_____	<input type="checkbox"/>	<input type="checkbox"/>	<input type="checkbox"/>
d) cancer	_____	<input type="checkbox"/>	<input type="checkbox"/>	<input type="checkbox"/>
e) arthritis	_____	<input type="checkbox"/>	<input type="checkbox"/>	<input type="checkbox"/>

- | | | | | | |
|----|-------------------|-----|--------------------------|--------------------------|--------------------------|
| f) | rheumatism | ___ | <input type="checkbox"/> | <input type="checkbox"/> | <input type="checkbox"/> |
| g) | back problems | ___ | <input type="checkbox"/> | <input type="checkbox"/> | <input type="checkbox"/> |
| h) | a joint disorder | ___ | <input type="checkbox"/> | <input type="checkbox"/> | <input type="checkbox"/> |
| i) | a muscle disorder | ___ | <input type="checkbox"/> | <input type="checkbox"/> | <input type="checkbox"/> |
| j) | a bone disorder | ___ | <input type="checkbox"/> | <input type="checkbox"/> | <input type="checkbox"/> |
| k) | spina bifida | ___ | <input type="checkbox"/> | <input type="checkbox"/> | <input type="checkbox"/> |

How much do the conditions that you indicated with a 'yes' below interfere with your activities?

		Yes / No	little or none	moderate	a great deal
Do you have or have you ever had these <u>foot</u> problems:					
a)	bunions (hallux valgus)	___	<input type="checkbox"/>	<input type="checkbox"/>	<input type="checkbox"/>
b)	hammer toes	___	<input type="checkbox"/>	<input type="checkbox"/>	<input type="checkbox"/>
c)	calluses	___	<input type="checkbox"/>	<input type="checkbox"/>	<input type="checkbox"/>
d)	ulcerations	___	<input type="checkbox"/>	<input type="checkbox"/>	<input type="checkbox"/>
e)	plantar fasciitis	___	<input type="checkbox"/>	<input type="checkbox"/>	<input type="checkbox"/>
f)	any other foot problems (diagnosed or not)	___	<input type="checkbox"/>	<input type="checkbox"/>	<input type="checkbox"/>
	_____	___	<input type="checkbox"/>	<input type="checkbox"/>	<input type="checkbox"/>
	_____	___	<input type="checkbox"/>	<input type="checkbox"/>	<input type="checkbox"/>
	_____	___	<input type="checkbox"/>	<input type="checkbox"/>	<input type="checkbox"/>

Have you ever severely injured or had surgery on your

- | | | | | | |
|----|-----------------------------|-----|--------------------------|--------------------------|--------------------------|
| a) | head | ___ | <input type="checkbox"/> | <input type="checkbox"/> | <input type="checkbox"/> |
| b) | neck | ___ | <input type="checkbox"/> | <input type="checkbox"/> | <input type="checkbox"/> |
| c) | back | ___ | <input type="checkbox"/> | <input type="checkbox"/> | <input type="checkbox"/> |
| d) | pelvis | ___ | <input type="checkbox"/> | <input type="checkbox"/> | <input type="checkbox"/> |
| e) | ankle, knee, or hip joints? | ___ | <input type="checkbox"/> | <input type="checkbox"/> | <input type="checkbox"/> |

How much do the conditions that you indicated with a 'yes' below interfere with your activities?

		Yes / No	little or none	moderate	a great deal
Have you ever broken any bones?					
		___	<input type="checkbox"/>	<input type="checkbox"/>	<input type="checkbox"/>
Which ones? : _____					

Have you had any recent (specify)

- | | | | | | |
|----|------------|-----|--------------------------|--------------------------|--------------------------|
| a) | illnesses | ___ | <input type="checkbox"/> | <input type="checkbox"/> | <input type="checkbox"/> |
| b) | injuries | ___ | <input type="checkbox"/> | <input type="checkbox"/> | <input type="checkbox"/> |
| c) | operations | ___ | <input type="checkbox"/> | <input type="checkbox"/> | <input type="checkbox"/> |

Do you have difficulties performing any daily activities?

		___	<input type="checkbox"/>	<input type="checkbox"/>	<input type="checkbox"/>
Which activities?: _____					

Have you ever experienced a fall?

Yes/No

How many times have you fallen within the last:

6 months: _____

Cause of fall(s): _____

Footwear worn during fall(s): _____

1 year: _____

Cause of fall(s): _____

Footwear worn during fall(s): _____

5 years: _____

Cause of fall(s): _____

Footwear worn during fall(s): _____

10 years: _____

Cause of fall(s): _____

Footwear worn during fall(s): _____

15 years: _____

Cause of fall(s): _____

Footwear worn during fall(s): _____

Are you currently taking any medications (prescription or over-the-counter), or other drugs?

Medication

Ailment

Frequency of use

_____	_____	_____
_____	_____	_____
_____	_____	_____
_____	_____	_____
_____	_____	_____
_____	_____	_____
_____	_____	_____
_____	_____	_____
_____	_____	_____
_____	_____	_____

Appendix B: Physical Activity Questionnaire

Participant: _____

Date: _____

Physical Activity Questionnaire

Please list the current physical activities you participate in:

Activity	How many times per week?	Duration	How long have you participated (#mths/#years)?
_____	_____	_____	_____
_____	_____	_____	_____
_____	_____	_____	_____
_____	_____	_____	_____
_____	_____	_____	_____
_____	_____	_____	_____
_____	_____	_____	_____

Of these activities, which leave you slightly out of breath?

Of these activities, which leave you breathless? (breathing hard enough that a conversation would be difficult)

Appendix D: Montreal Cognitive Assessment (MoCA) Test

MONTREAL COGNITIVE ASSESSMENT (MOCA)
Version 7.1 Original Version

NAME:
Education:
Sex:

Date of birth:
DATE:

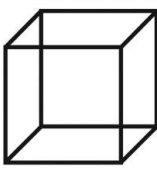
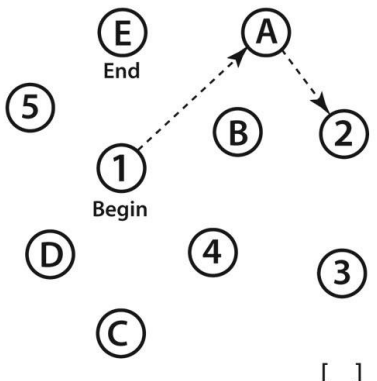
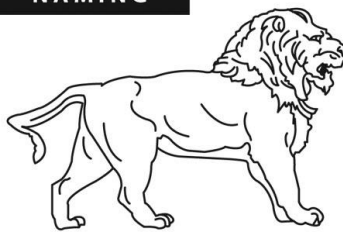
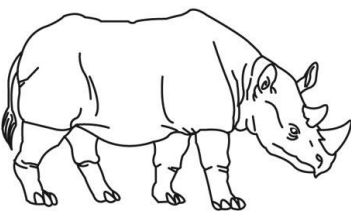
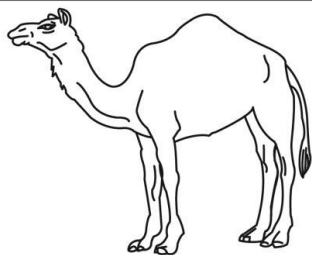
VISUOSPATIAL / EXECUTIVE							Copy cube	Draw CLOCK (Ten past eleven) (3 points)	POINTS								
		<input type="checkbox"/> <input type="checkbox"/> <input type="checkbox"/> <input type="checkbox"/> <input type="checkbox"/>					<input type="checkbox"/> <input type="checkbox"/> <input type="checkbox"/>	<input type="checkbox"/> <input type="checkbox"/> <input type="checkbox"/>	___/5								
NAMING																	___/3
MEMORY		Read list of words, subject must repeat them. Do 2 trials, even if 1st trial is successful. Do a recall after 5 minutes.		FACE	VELVET	CHURCH	DAISY	RED	No points								
		1st trial															
		2nd trial															
ATTENTION		Read list of digits (1 digit/ sec.).		Subject has to repeat them in the forward order			[] 2 1 8 5 4			___/2							
				Subject has to repeat them in the backward order			[] 7 4 2										
		Read list of letters. The subject must tap with his hand at each letter A. No points if ≥ 2 errors										___/1					
		[] FBACMNAAJKLBAFAKDEAAAJAMOF AAB															
LANGUAGE		Repeat: I only know that John is the one to help today. [] The cat always hid under the couch when dogs were in the room. []										___/2					
		Fluency / Name maximum number of words in one minute that begin with the letter F [] ____ (N ≥ 11 words)										___/1					
ABSTRACTION		Similarity between e.g. banana - orange = fruit [] train - bicycle [] watch - ruler										___/2					
DELAYED RECALL		Has to recall words WITH NO CUE		FACE	VELVET	CHURCH	DAISY	RED	Points for UNCUEDE recall only			___/5					
		Category cue															
Optional		Multiple choice cue															
ORIENTATION		[] Date		[] Month		[] Year		[] Day		[] Place		[] City		___/6			
© Z.Nasreddine MD		www.mocatest.org					Normal ≥ 26 / 30					TOTAL ___/30					
Administered by: _____												Add 1 point if ≤ 12 yr edu					

Appendix E: Berg Balance Scale Test

Berg Balance Scale

Name: _____

Date: _____

1. SITTING TO STANDING

INSTRUCTIONS: Please stand up. Try not to use your hand for support.

- 4 able to stand without using hands and stabilize independently
- 3 able to stand independently using hands
- 2 able to stand using hands after several tries
- 1 needs minimal aid to stand or stabilize
- 0 needs moderate or maximal assist to stand

2. STANDING UNSUPPORTED

INSTRUCTIONS: Please stand for two minutes without holding on.

- 4 able to stand safely for 2 minutes
- 3 able to stand 2 minutes with supervision
- 2 able to stand 30 seconds unsupported
- 1 needs several tries to stand 30 seconds unsupported
- 0 unable to stand 30 seconds unsupported

If a subject is able to stand 2 minutes unsupported, score full points for sitting unsupported.
Proceed to item #4.

3. SITTING WITH BACK UNSUPPORTED BUT FEET SUPPORTED ON FLOOR OR ON A STOOL

INSTRUCTIONS: Please sit with arms folded for 2 minutes.

- 4 able to sit safely and securely for 2 minutes
- 3 able to sit 2 minutes under supervision
- 2 able to sit 30 seconds
- 1 able to sit 10 seconds
- 0 unable to sit without support 10 seconds

4. STANDING TO SITTING

INSTRUCTIONS: Please sit down.

- 4 sits safely with minimal use of hands
- 3 controls descent by using hands
- 2 uses back of legs against chair to control descent
- 1 sits independently but has uncontrolled descent
- 0 needs assist to sit

5. TRANSFERS

INSTRUCTIONS: Arrange chair(s) for pivot transfer. Ask subject to transfer one way toward a seat with armrests and one way toward a seat without armrests. You may use two chairs (one with and one without armrests) or a bed and a chair.

- 4 able to transfer safely with minor use of hands

- () 3 able to transfer safely definite need of hands
- () 2 able to transfer with verbal cuing and/or supervision
- () 1 needs one person to assist
- () 0 needs two people to assist or supervise to be safe

6. STANDING UNSUPPORTED WITH EYES CLOSED

INSTRUCTIONS: Please close your eyes and stand still for 10 seconds.

- () 4 able to stand 10 seconds safely
- () 3 able to stand 10 seconds with supervision
- () 2 able to stand 3 seconds
- () 1 unable to keep eyes closed 3 seconds but stays safely
- () 0 needs help to keep from falling

7. STANDING UNSUPPORTED WITH FEET TOGETHER

INSTRUCTIONS: Place your feet together and stand without holding on.

- () 4 able to place feet together independently and stand 1 minute safely
- () 3 able to place feet together independently and stand 1 minute with supervision
- () 2 able to place feet together independently but unable to hold for 30 seconds
- () 1 needs help to attain position but able to stand 15 seconds feet together
- () 0 needs help to attain position and unable to hold for 15 seconds

8. REACHING FORWARD WITH OUTSTRETCHED ARM WHILE STANDING

INSTRUCTIONS: Lift arm to 90 degrees. Stretch out your fingers and reach forward as far as you can. (Examiner places a ruler at the end of fingertips when arm is at 90 degrees. Fingers should not touch the ruler while reaching forward. The recorded measure is the distance forward that the fingers reach while the subject is in the most forward lean position. When possible, ask subject to use both arms when reaching to avoid rotation of the trunk.)

- () 4 can reach forward confidently 25 cm (10 inches)
- () 3 can reach forward 12 cm (5 inches)
- () 2 can reach forward 5 cm (2 inches)
- () 1 reaches forward but needs supervision
- () 0 loses balance while trying/requires external support

9. PICK UP OBJECT FROM THE FLOOR FROM A STANDING POSITION

INSTRUCTIONS: Pick up the shoe/slipper, which is placed in front of your feet.

- () 4 able to pick up slipper safely and easily
- () 3 able to pick up slipper but needs supervision
- () 2 unable to pick up but reaches 2-5 cm(1-2 inches) from slipper and keeps balance independently
- () 1 unable to pick up and needs supervision while trying
- () 0 unable to try/needs assist to keep from losing balance or falling

Berg Balance Scale continued....

10. TURNING TO LOOK BEHIND OVER LEFT AND RIGHT SHOULDERS WHILE STANDING

INSTRUCTIONS: Turn to look directly behind you over toward the left shoulder. Repeat to the right. Examiner may pick an object to look at directly behind the subject to encourage a better twist turn.

- () 4 looks behind from both sides and weight shifts well
- () 3 looks behind one side only other side shows less weight shift
- () 2 turns sideways only but maintains balance
- () 1 needs supervision when turning
- () 0 needs assist to keep from losing balance or falling

11. TURN 360 DEGREES

INSTRUCTIONS: Turn completely around in a full circle. Pause. Then turn a full circle in the other direction.

- () 4 able to turn 360 degrees safely in 4 seconds or less
- () 3 able to turn 360 degrees safely one side only 4 seconds or less
- () 2 able to turn 360 degrees safely but slowly
- () 1 needs close supervision or verbal cuing
- () 0 needs assistance while turning

12. PLACE ALTERNATE FOOT ON STEP OR STOOL WHILE STANDING UNSUPPORTED

INSTRUCTIONS: Place each foot alternately on the step/stool. Continue until each foot has touch the step/stool four times.

- () 4 able to stand independently and safely and complete 8 steps in 20 seconds
- () 3 able to stand independently and complete 8 steps in > 20 seconds
- () 2 able to complete 4 steps without aid with supervision
- () 1 able to complete > 2 steps needs minimal assist
- () 0 needs assistance to keep from falling/unable to try

13. STANDING UNSUPPORTED ONE FOOT IN FRONT

INSTRUCTIONS: (DEMONSTRATE TO SUBJECT) Place one foot directly in front of the other. If you feel that you cannot place your foot directly in front, try to step far enough ahead that the heel of your forward foot is ahead of the toes of the other foot. (To score 3 points, the length of the step should exceed the length of the other foot and the width of the stance should approximate the subject's normal stride width.)

- () 4 able to place foot tandem independently and hold 30 seconds
- () 3 able to place foot ahead independently and hold 30 seconds
- () 2 able to take small step independently and hold 30 seconds
- () 1 needs help to step but can hold 15 seconds
- () 0 loses balance while stepping or standing

14. STANDING ON ONE LEG

INSTRUCTIONS: Stand on one leg as long as you can without holding on.

- 4 able to lift leg independently and hold > 10 seconds
- 3 able to lift leg independently and hold 5-10 seconds
- 2 able to lift leg independently and hold \geq 3 seconds
- 1 tries to lift leg unable to hold 3 seconds but remains standing independently.
- 0 unable to try or needs assist to prevent fall

TOTAL SCORE (Maximum = 56)

Appendix F: Footwear Assessment Form

Appendix 1: FOOTWEAR ASSESSMENT TOOL

1. FIT

Foot length

Thumb width

Fit of shoe (length) – rule of thumb (wearer's thumb)

Palpation:

good

too short (< ½ thumb)

too long (> 1 ½)

Straw =

good

too short (< ½ thumb)

too long (> 1 ½)

Fit of shoe (width) – grasp test

good

too narrow

too wide

Fit of shoe (depth)

good

too shallow

2. GENERAL

Age of shoe

0 – 6 months

6 – 12 months

> 12 months

Footwear style

walking shoe

boot

slipper

sandal

athletic shoe

ugg-boot

backless slipper

surgical/bespoke

oxford shoe

high heel

court shoe

other (specify)

moccasin

Thong/flip-flop

mule

Materials (upper)

leather

synthetic

mesh

other

Materials (outsole)

rubber

plastic

leather

other

Weight

Length

Weight/length

3. GENERAL STRUCTURE

Heel height =

0 – 2.5 cm

2.6 – 5.0 cm

> 5.0 cm

Forefoot height (measured at point of the 1st and MTPJs) =

0 – 0.9 cm

1.0 – 2.0 cm

> 2.0 cm

Longitudinal profile (heel – forefoot difference) =

flat (0 – 0.9 cm)

small heel rise (1 – 3 cm)

large heel rise (> 3 cm)

Last (centre goniometer at 50% shoe length) =

straight (< 5°)

semi-curved (5 – 15°)

curved (> 15°)

Fixation of upper to sole

board

combination

slip-lasted

Forefoot sole flexion point

at level of MTPJs

proximal to 1st MTPJ

distal to 1st MTPJ

4. MOTION CONTROL PROPERTIES

Density single dual

Fixation none laces straps/buckles Velcro zips
Number of eyelets

Heel counter stiffness (20mm above bottom or upper)

no heel counter minimal (> 45°) moderate (< 45°) rigid (0-10°)

Midfoot sole sagittal stability

minimal (> 45°) moderate (< 45°) rigid (0-10°)

Midfoot sole frontal stability (torsional)

minimal (> 45°) moderate (< 45°) rigid (0-10°)

5. CUSHIONING

Presence none heel heel/forefoot

Lateral Midsole hardness

Durometer readings

soft		firm		hard		mean	
1 st		2 nd		3 rd		mean	

Medial Midsole hardness

Durometer readings

soft		firm		hard		mean	
1 st		2 nd		3 rd		mean	

Heel sole hardness (centre of inside heel shoe interface)

Durometer readings

soft		firm		hard		mean	
1 st		2 nd		3 rd		mean	

6. WEAR PATTERNS

Upper medial tilt (> 10°) neutral lateral tilt (> 10°)

Midsole medial compression signs neutral lateral compression signs

Tread pattern A B textured not worn smooth (i.e. no pattern) partly worn fully worn

Outsole wear pattern none normal lateral medial

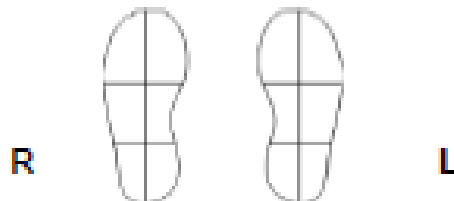

Appendix G: Results Tables

Table 3: Maximum ML COM-COP analysis between footwear conditions for L2 stance of GT.

Analysis Variable : L2MLCMCPmx							
ft	N Obs	Mean	Std Dev	Std Error	Minimum	Maximum	N
No Insole	43	0.2167	0.0587	0.0102	0.1364	0.3312	33
Insole	40	0.2471	0.0605	0.0114	0.1303	0.3515	28
Barefoot	46	0.2683	0.0589	0.0094	0.1392	0.3473	39

Table 4: Minimum ML COM-COP analysis between footwear conditions for L2 stance of GT.

Analysis Variable : L2MLCMCPmn							
ft	N Obs	Mean	Std Dev	Std Error	Minimum	Maximum	N
No Insole	43	0.0684	0.0674	0.0117	0.0005	0.2191	33
Insole	40	0.118	0.0782	0.0148	0.0007	0.2687	28
Barefoot	46	0.12	0.0792	0.0127	0.0005	0.2917	39

Table 5: Vertical force loading rate analysis between footwear conditions for L2 stance of GT.

Analysis Variable : LS2ROL							
ft	N Obs	Mean	Std Dev	Std Error	Minimum	Maximum	N
No Insole	43	544.3605	272.0241	41.4833	40.6	1576.9	43
Insole	40	593.63	265.4684	41.9742	322.2	1811.9	40
Barefoot	46	530.7565	220.844	32.5617	67.8	1284.2	46

Table 6: Vertical force loading rate analysis between footwear conditions for R3 stance of GT.

Analysis Variable : RS3ROL							
ft	N Obs	Mean	Std Dev	Std Error	Minimum	Maximum	N
No Insole	43	317.2349	166.8089	25.4381	63.9	708.2	43
Insole	40	189.705	90.7733	14.3525	50.8	416.6	40
Barefoot	46	292.5087	132.5147	19.5382	80.6	653.6	46

Table 7: Step width analysis between footwear conditions for L2step of GT.

Analysis Variable : L2SW							
ft	N Obs	Mean	Std Dev	Std Error	Minimum	Maximum	N

No Insole	43	0.0972	0.08	0.0146	0.013	0.45	30
Insole	40	0.0897	0.0647	0.0129	0.008	0.222	25
Barefoot	46	0.0665	0.0361	0.0058	0.002	0.145	39

Table 8: Step width analysis between footwear conditions for R3 step of GT.

Analysis Variable : R3SW							
ft	N Obs	Mean	Std Dev	Std Error	Minimum	Maximum	N
No Insole	43	0.1104	0.0735	0.0121	0.001	0.415	37
Insole	40	0.1095	0.0449	0.0081	0.036	0.222	31
Barefoot	46	0.1133	0.0534	0.008	0.052	0.275	45

Table 9: Step length analysis between footwear conditions for L2 step of GT.

Analysis Variable : L2SL							
ft	N Obs	Mean	Std Dev	Std Error	Minimum	Maximum	N
No Insole	43	0.5609	0.1307	0.0239	0.054	0.723	30
Insole	40	0.4784	0.1647	0.0329	0.019	0.68	25
Barefoot	46	0.5373	0.1087	0.0174	0.083	0.705	39

Table 10: Step length analysis between footwear conditions for R3 step of GT.

Analysis Variable : R3SL							
ft	N Obs	Mean	Std Dev	Std Error	Minimum	Maximum	N
No Insole	43	0.2746	0.2372	0.039	0.003	0.685	37
Insole	40	0.1855	0.2223	0.0399	0.001	0.595	31
Barefoot	46	0.1822	0.2236	0.0333	0.002	0.666	45

Table 11: Average gait velocity difference analysis between footwear conditions between R2 and L2 stances of GT.

Analysis Variable : AGV_R2L2							
ft	N Obs	Mean	Std Dev	Std Error	Minimum	Maximum	N
No Insole	43	0.2728	0.3239	0.0494	-0.79	0.76	43
Insole	40	0.3475	0.3442	0.0544	-0.5	0.84	40
Barefoot	46	0.4211	0.2517	0.0371	-0.48	0.72	46

Table 12: Maximum ML COM-COP analysis between footwear conditions for R3 stance of NW.

Analysis Variable : R3MLCMCPmx							
ft	N Obs	Mean	Std Dev	Std Error	Minimum	Maximum	N
No Insole	130	0.1677	0.0408	0.0044	0.1086	0.3131	87
Insole	128	0.1631	0.0408	0.0045	0.0988	0.3532	84
Barefoot	131	0.1709	0.0405	0.004	0.1207	0.3771	104

Table 13: Minimum ML COM-COP analysis between footwear conditions for R3 stance of NW.

Analysis Variable : R3MLCMCPmn							
ft	N Obs	Mean	Std Dev	Std Error	Minimum	Maximum	N
No Insole	130	0.0459	0.0585	0.0063	0	0.1917	87
Insole	128	0.059	0.0593	0.0065	0	0.1684	84
Barefoot	131	0.047	0.0715	0.007	0	0.3771	104

Table 14: Vertical force loading rate analysis between footwear conditions for R3 stance of NW.

Analysis Variable : RS3ROL							
ft	N Obs	Mean	Std Dev	Std Error	Minimum	Maximum	N
No Insole	131	357.584	178.9546	15.6353	62.6	1966.1	131
Insole	128	351.2484	115.9482	10.2485	53.6	937.2	128
Barefoot	131	356.1786	123.7129	10.8088	128	777.3	131

Table 15: Step width analysis between footwear conditions for R3 step of NW.

Analysis Variable : R3SW							
ft	N Obs	Mean	Std Dev	Std Error	Minimum	Maximum	N
No Insole	131	0.0784	0.0446	0.0042	0.001	0.191	113
Insole	128	0.0744	0.0408	0.004	0.002	0.161	103
Barefoot	131	0.0735	0.0378	0.0035	0	0.158	115

Table 16: Step length analysis between footwear conditions for R3 step of NW.

Analysis Variable : R3SL							
ft	N Obs	Mean	Std Dev	Std Error	Minimum	Maximum	N
No	131	0.6238	0.0643	0.006	0.474	0.858	113

Insole							
Insole	128	0.6128	0.0674	0.0066	0.305	0.827	103
Barefoot	131	0.5587	0.0572	0.0053	0.429	0.704	115

Table 17: Maximum ML COM-COP analysis between footwear conditions for R3 stance of CW.

Analysis Variable : R3MLCMCPmx							
ft	N Obs	Mean	Std Dev	Std Error	Minimum	Maximum	N
No Insole	56	0.1734	0.0514	0.0086	0.073	0.3077	36
Insole	61	0.1592	0.036	0.006	0.0799	0.2332	36
Barefoot	60	0.1681	0.0427	0.0064	0.1144	0.351	44

Table 18: Minimum ML COM-COP analysis between footwear conditions for R3 stance of CW.

Analysis Variable : R3MLCMCPmn							
ft	N Obs	Mean	Std Dev	Std Error	Minimum	Maximum	N
No Insole	56	0.0511	0.07	0.0117	0.0001	0.22	36
Insole	61	0.0456	0.0523	0.0087	0.0003	0.1526	36
Barefoot	60	0.0378	0.0575	0.0087	0	0.1939	44

Table 19: Vertical force loading rate analysis between footwear conditions for R3 stance of CW.

Analysis Variable : RS3ROL							
ft	N Obs	Mean	Std Dev	Std Error	Minimum	Maximum	N
No Insole	56	315.8446	102.7959	13.7367	91.8	563.7	56
Insole	62	333.9355	101.8857	12.9395	48.4	514.7	62
Barefoot	59	349.7458	87.736	11.4222	137.4	571.5	59

Table 20: Step width analysis between footwear conditions for R3 step of CW.

Analysis Variable : R3SW							
ft	N Obs	Mean	Std Dev	Std Error	Minimum	Maximum	N
No Insole	56	0.0687	0.0455	0.0068	0.006	0.166	45
Insole	62	0.0705	0.0385	0.0062	0.004	0.154	38
Barefoot	59	0.0662	0.0376	0.0053	0.009	0.141	51

Table 21: Step length analysis between footwear conditions for R3 step of CW.

Analysis Variable : R3SL							
ft	N Obs	Mean	Std Dev	Std Error	Minimum	Maximum	N
No Insole	56	0.5813	0.0984	0.0147	0.077	0.732	45
Insole	62	0.5989	0.0588	0.0095	0.473	0.743	38
Barefoot	59	0.5569	0.0703	0.0099	0.403	0.677	51