



1981

S-Adenosyl- L-Methionine And S-Adenosyl- L-Homocysteine: A Nuclear Magnetic Resonance Study And Purification Of S-Adenosyl- L-Methionine: L-Homocysteine S-Methyltransferase From *Saccharomyces Cerevisiae*

Mark Lewis Stolowitz
University of the Pacific

Follow this and additional works at: https://scholarlycommons.pacific.edu/uop_etds

 Part of the [Physical Sciences and Mathematics Commons](#)

Recommended Citation

Stolowitz, Mark Lewis. (1981). *S-Adenosyl- L-Methionine And S-Adenosyl- L-Homocysteine: A Nuclear Magnetic Resonance Study And Purification Of S-Adenosyl- L-Methionine: L-Homocysteine S-Methyltransferase From Saccharomyces Cerevisiae*. University of the Pacific, Dissertation. https://scholarlycommons.pacific.edu/uop_etds/3158

This Dissertation is brought to you for free and open access by the Graduate School at Scholarly Commons. It has been accepted for inclusion in University of the Pacific Theses and Dissertations by an authorized administrator of Scholarly Commons. For more information, please contact mgibney@pacific.edu.

S-ADENOSYL-L-METHIONINE AND S-ADENOSYL-L-HOMOCYSTEINE
A NUCLEAR MAGNETIC RESONANCE STUDY
AND
PURIFICATION OF S-ADENOSYL-L-METHIONINE: L-HOMOCYSTEINE
S-METHYLTRANSFERASE FROM SACCHAROMYCES CEREVISIAE

A Dissertation
Presented to
the Faculty of the Graduate School
University of the Pacific

In Partial Fulfillment
of the Requirements for the Degree
Doctor of Philosophy

by
Mark Lewis Stolowitz

November 1981

This dissertation, written and submitted by

Mark Lewis Stolowitz

is approved for recommendation to the Committee
on Graduate Studies, University of the Pacific

Dean of the School or Department Chairman:

Harry O. Speer

Dissertation Committee:

Michael J. Miner Chairman

James W. Blankenship

Charles A. Matuszko

Paul H. Goetz

Shodor G. J.

Dated November 13, 1981

ACKNOWLEDGEMENT

I wish to express my appreciation to Dr. Michael J. Minch for his continued encouragement and support throughout my undergraduate and graduate studies at Pacific. I am honored to have been afforded the opportunity to prepare the first doctoral dissertation under his direction.

ABSTRACT OF DISSERTATION

An analysis of the 360 MHz ^1H NMR spectra of the title compounds in $^2\text{H}_2\text{O}$ is presented. The ^3J values for the ribose vicinal protons of S-adenosyl-L-methionine are consistent with a predominantly $\text{C}_{3'}$ -exo conformation and with one highly favored gauche-anti conformation about the $\text{C}_{4'}$ - $\text{C}_{5'}$ bond. The corresponding ^3J values for S-adenosyl-L-homocysteine imply a similar $\text{C}_{3'}$ -exo ribose ring conformation, but the orientation about the $\text{C}_{4'}$ - $\text{C}_{5'}$ bond is distributed between two gauche-anti rotamers. The methionine side chain of S-adenosyl-L-methionine has approximately equal populations of rotational isomers about the C_α - C_β and C_β - C_γ bonds, whereas the side chain of S-adenosyl-L-homocysteine exhibits a conformational preference for the gauche-anti conformations about the C_α - C_β bond. ^1H and ^{13}C NMR spectra of commercially available samples of (-)S-adenosyl-L-methionine consistently reveal the presence of a small amount of the (+) sulfonium diastereomer. This assignment was confirmed by the synthesis of both the ^1H and ^{13}C methyl derivatives of S-adenosyl-L-homocysteine. Arguments are presented to explain the failure of previous workers to detect (+)S-adenosyl-L-methionine in biological preparations. The possible biological significance of this finding is discussed with reference to the enzyme S-adenosyl-L-methionine: L-homocysteine S-methyltransferase which employs both (-)S-adenosyl-L-methionine and (+)S-adenosyl-L-methionine as methyl donors.

An improved purification of S-Adenosyl-L-methionine: L-homocysteine S-methyltransferase (EC. 2.1.1.10) from Saccharomyces cerevisiae is reported. The enzyme was purified approximately 1500-fold by toluene extraction, ammonium sulfate precipitation, Sephadex G25 gel exclusion chromatography, DEAE Sephadex ion-exchange chromatography and affinity chromatography on L-methionine AH-Sepharose 4B. The procedure affords a 12-fold increase in yield and a 3-fold increase in purification over the previous fractionation scheme. It is hoped that the availability of a highly purified preparation of the enzyme will provide the basis for an investigation of enzymatic transmethylation in which the fate of the sulfonium diastereomers of S-adenosyl-L-methionine is directly observable by NMR spectroscopy.

TABLE OF CONTENTS

INTRODUCTION	1
MATERIALS AND METHODS	16
Materials	16
Spectroscopic Methods	17
Enzyme and Protein Assays	17
Methionine Assay	18
S-Adenosyl-L-homocysteine Assay	21
Purification of HSMT	26
Toluene Extraction	26
Ammonium Sulfate Precipitation	27
Gel Exclusion Chromatography	27
Ion-Exchange Chromatography	28
Affinity Chromatography	29
Isoelectric Focusing	30
SDS Gel Electrophoresis	31
RESULTS AND DISCUSSION	33
NMR Spectroscopy of SAM and SAH	33
Conformational Analysis of S-Adenosyl-L-methionine	38
Conformation of the Ribose Ring	38
Conformation About the Exocyclic Bond	43
Conformation of the Methionine Side Chain	46
Conformational Analysis of S-Adenosyl-L-homocysteine	46
Comparison Between SAM and SAH	47
The Sulfonium Methyl Group	48

Purification of HSMT	53
Toluene Extraction	54
Ammonium Sulfate Precipitation	54
Gel Exclusion Chromatography	56
Ion-Exchange Chromatography	56
Affinity Chromatography	57
BIBLIOGRAPHY	61

INTRODUCTION

The unique versatility of S-adenosyl-L-methionine (SAM) is most easily understood by consideration of its chemical structure,¹ Figure 1. Distributed about the asymmetric sulfonium pole are methyl, aminobutyryl and adenosyl moieties subject to enzymatic transfer or cleavage.² This ubiquitous cofactor functions as the principal biological donor of methyl groups,³ as donor of the aminobutyryl side chain,⁴ as the source of the propylamine moieties of spermine and spermidine,⁵ as adenosyl donor to tripolyphosphate,⁶ and as an allosteric effector in several systems. No other biological compound exhibits such broad versatility. Trans-methylations involving S-adenosyl-L-methionine proceed with the concomitant release of S-adenosyl-L-homocysteine (SAH),⁷ Figure 2. SAH is a potent inhibitor of all transmethylation reactions except those involving the methylation of DNA⁸ and is believed to play an important regulatory role.⁹

We have undertaken the investigation of S-adenosyl-L-methionine and S-adenosyl-L-homocysteine by nuclear magnetic resonance (NMR) spectroscopy to ascertain and compare the details of their molecular conformations. Conformational details are presently limited. Attempts at X-ray crystallographic studies of SAM have been unsuccessful although a model sulfonium compound with labile methyl groups, S-methyl-L-methionine, has been investigated.¹⁰ Talalay *et al.*¹¹ have determined crystallographically the absolute configuration at

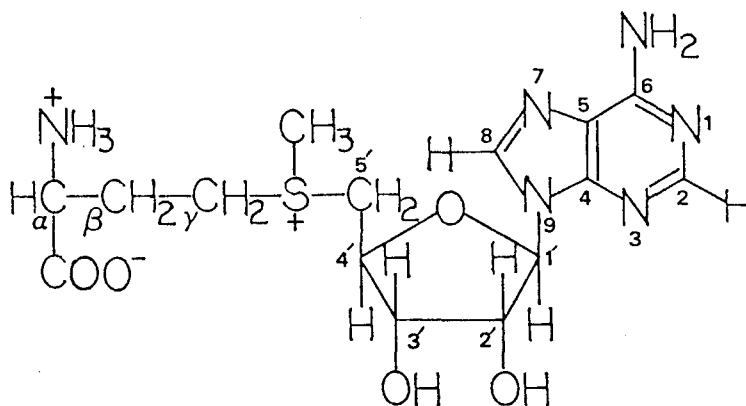

FIGURE 1. S-Adenosyl-L-methionine (SAM)

the sulfonium center of a pair of diastereomeric S-carboxymethyl-(S)-methionine salts. Degradation of S-adenosyl-L-($^{14}\text{C}_3\text{H}_3\text{S}$)-methionine to S-carboxymethyl-(S)-methionine under conditions designed to retain the configuration at the sulfonium center have shown the product to possess the physical properties of the diastereomer with the S configuration. This study did reveal, however, the presence of a radioactive impurity which was eluted from an amino acid analyzer at the retention time of the sulfonium diastereomer of the opposite configuration. Klee and Mudd¹² have examined S-adenosyl-DL-methionine, S-adenosyl-DL-homocysteine and structurally related compounds by optical rotatory dispersion. They have suggested that the purine ring systems in all 5' sulfur-substituted nucleosides are oriented preferentially in the anti¹³ conformation.

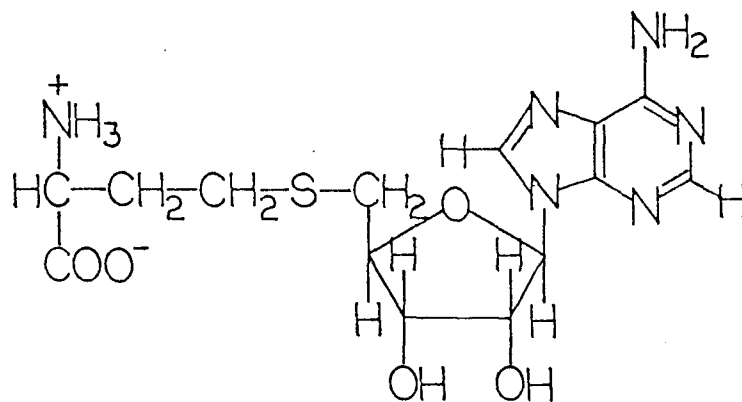

FIGURE 2. S-Adenosyl-L-homocysteine (SAH)

Hegazi et al.¹⁴ have observed that the velocity of transmethylation from S-adenosyl-L-methionine to 3,4-dihydroxyacetophenone, catalyzed by catechol O-methyltransferase, is increased by trideuteration of the sulfonium methyl group. They report that the observed α -deuterium secondary isotope effect is exactly what is observed for many classical S_N2 reactions in organic reaction systems. Arigoni¹⁵ has prepared S-methyl-L-methionine carrying chiral CHDT groups in place of the sulfonium methyl groups. Inversion mechanisms were detected for enzymatic transmethylation on carbon, sulfur and oxygen involving S-methyl-L-methionine as methyl donor.

Barchas and Deguchi⁹ have proposed that biological transmethylation reactions are controlled by the product inhibition of S-adenosyl-L-homocysteine. The level of SAH is

in turn controlled by the enzyme adenosylhomocysteinase, which catalyzes the reversible condensation of adenosine and L-homocysteine to form SAH.¹⁶ An extensive collection of structural analogs of SAH have been prepared and evaluated as inhibitors of enzymatic transmethylation. With few exceptions, analogs of SAH have been prepared synthetically due to the narrow substrate specificity of adenosylhomocysteinase.

Modifications of the amino acid portion of SAH have been prepared by Coward, Borchardt, Hildesheim and coworkers. Borchardt¹⁷ evaluated several amino acid modifications as inhibitors of the enzymes: catechol O-methyltransferase, phenylethanolamine N-methyltransferase, histamine N-methyltransferase and hydroxyindole O-methyltransferase. The terminal amino group of L-SAH appears to be essential as N-acetyl-SAH and deaminated derivatives exhibit little inhibitory activity. Decarboxylated derivatives exhibit reduced inhibitory activity. D-SAH exhibits reduced inhibitory activity with respect to catechol O-methyltransferase, phenylethanolamine N-methyltransferase and hydroxyindole O-methyltransferase. Modifications of the amino acid portion of SAH are summarized in Table 1.

Modifications of the base portion of SAH have also been evaluated with respect to the aforementioned enzymes. Replacement of the adenine moiety with other purine or pyrimidine bases results in complete loss of inhibitory activity. The loss of the 6-amino group from the purine ring similarly results in complete loss of inhibitory activity.

TABLE 1. Structural Analogs of S-Adenosyl-L-homocysteine
Modifications of the Amino Acid Portion

C ^a	R	Ref.
L	SCH ₂ CH ₂ CH(COOH)NH ₂	SAH
D	SCH ₂ CH ₂ CH(COOH)NH ₂	17
L	SCH ₂ CH(COOH)NH ₂	19
D	SCH ₂ CH ₂ CH(COOH)NHAc	19
	SCH ₂ CH ₂ CH ₂ NH ₂	17
	SCH ₂ CH ₂ NH ₂	18
	SCH ₂ CH ₂ CH ₂ NHAc	17
	SCH ₂ CH ₂ NHAc	18
	SCH ₂ CH ₂ CH ₂ COOH	18
	SCH ₂ CH ₂ COOH	18
	SCH ₂ CHOHCH ₂ OH	18
	SCH ₂ CH ₂ CH ₂ CH ₃	18
	SCH ₂ CH ₂ CH ₂ CH ₂ CH ₃	18
	SCH ₂ CH(CH ₃) ₂	18
	SCH ₂ CH ₂ OH	18
	OCH ₂ CH ₂ OH	18
DL	SCH ₂ CH ₂ CH(COOH)CH ₃	17
DL	SCH ₂ CH ₂ CH(COOH)NHAc	17
L	(SO)CH ₂ CH ₂ CH(COOH)NH ₂	17
D	(SO)CH ₂ CH ₂ CH(COOH)NH ₂	17
L	(SO ₂)CH ₂ CH ₂ CH(COOH)NH ₂	17

^aConfiguration at alpha carbon.

Methylation of the 6-amino group results in a sharp decrease in inhibitory activity. These data point to a strict requirement for the adenine moiety in methyltransferase binding. Structural analogs of SAH containing modifications of the base portion are summarized in Table 2.

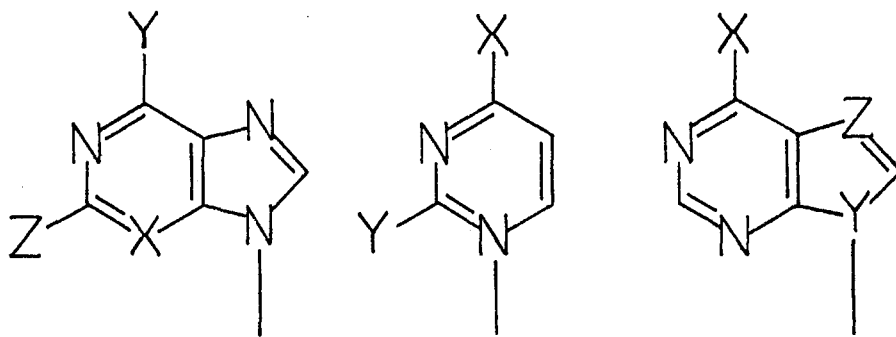

TABLE 2. Structural Analogs of S-Adenosyl-L-homocysteine Modifications of the Base Portion

R ₁			R ₂		R ₃			Ref.
X	Y	Z	X	Y	X	Y	Z	
N	NH ₂	H						SAH
N	OH	NH ₂						20
N	OH	H						20
N	NHCH ₃	H						20
CH	NH ₂	H						20
CH	NHCH ₃	H						20
CH	N(CH ₃) ₂	H						20
CH	Cl	H						20
			OH	OH				20
			NH ₂	OH				20
					NH ₂	CH	CH	17
					NH ₂	N	N	17
					NHCH ₃	N	CH	17
					N(CH ₃) ₂	N	CH	17

Modification of the sugar portion of SAH has demonstrated a requirement for the unaltered ribose ring except with phenylethanolamine N-methyltransferase, for which the 2'-deoxyadenosine derivative exhibited inhibitory activity. Modifications of the sugar portion of SAH are summarized in Tables 3 and 4.

The preparation of structural analogs of SAM has proven useful in determining the nature of the transmethylase binding site for this cofactor. Modifications of SAM are summarized in Table 5 and include substitution at the 6-position of the purine ring, at the site of the alkyl sulfonium group and at the α -carbon of the methionine side chain. Zappia et al.²⁴ have proposed that SAM binds to transmethylases via interactions of the 6-amino group of the purine ring, the sulfonium ion and the α -amino and α -carboxyl groups of the methionine side chain. Mudd and Cantoni²⁵ have prepared Se-adenosyl-DL-selenomethionine from yeast grown in the presence of selenomethionine and found this compound to be active in the methylation of guanidinoacetic acid.

The sulfonium diastereomers of S-adenosyl-L-methionine and S-adenosyl-D-methionine were first prepared by De La Haba et al.,²⁶ who determined their optical rotations. The methionine activating enzymes (methionine adenosyltransferase) of yeast and liver were shown to yield products of the same configuration ((-)-SAM). Guanidinoacetate methyltransferase, S-adenosylmethionine cleaving enzyme of yeast and catechol O-methyltransferase were shown to exhibit identical steric requirements with respect to the sulfonium center. A

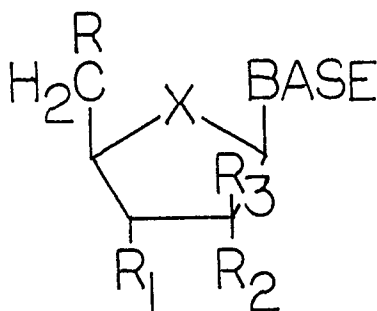

TABLE 3. Structural Analogs of S-Adenosyl-L-homocysteine Modifications of the Sugar Portion

X	R ₁	R ₂	R ₃	Ref.
O	OH	OH	H	SAH
O	OH	H	H	21
O	H	OH	H	21
O	OH	H	OH	21
CH ₂	OH	OH	H	22

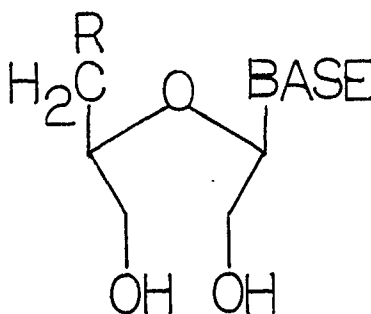

TABLE 4. Structural Analogs of S-Adenosyl-L-homocysteine 2'3'-Acyclic Derivatives of SAH

Base	C ^a	R	Ref.
adenine	L	SCH ₂ CH ₂ CH(COOH)NH ₂	23
adenine	D	SCH ₂ CH ₂ CH(COOH)NH ₂	23
adenine	DL	SCH ₂ CH(COOH)NH ₂	23
adenine	L	(SO)CH ₂ CH ₂ CH(COOH)NH ₂	23
2-azaadenine	DL	SCH ₂ CH ₂ CH(COOH)NH ₂	23
8-azaadenine	DL	SCH ₂ CH ₂ CH(COOH)NH ₂	23

^aConfiguration at alpha carbon.

mixture of sulfonium diastereomers ((\pm)SAM) were prepared by methylation of S-adenosyl-L-homocysteine. Reaction with the enzymes described above ceased after the utilization of approximately 50% of the (\pm)SAM. The sulfonium diastereomer with the configuration opposite that of the product of the methionine activating enzymes (($+$)SAM) was isolated from the reaction of (\pm)SAM with guanidinoacetate methyltransferase.

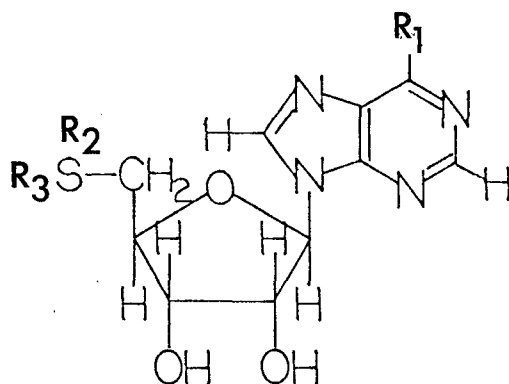

TABLE 5. Structural Analogs of S-Adenosyl-L-methionine

R ₁	S ^a	R ₂	C ^b	R ₃	Ref.
NH ₂	(-)	CH ₃	L	CH ₂ CH ₂ CH(COOH)NH ₂	SAM
NH ₂	(\pm)	CH ₂ CH ₃	L	CH ₂ CH ₂ CH(COOH)NH ₂	27
NH ₂	(-)	CH ₃		CH ₂ CH ₂ CH ₂ NH ₂	24
NH ₂	(-)	CH ₃	L	CH ₂ CH ₂ CH(COOH)OH	24
OH	(-)	CH ₃	L	CH ₂ CH ₂ CH(COOH)NH ₂	24
OH	(-)	CH ₃	L	CH ₂ CH ₂ CH(COOH)OH	24
NH ₂	(?)	CH ₂ CH ₂ CH ₃	L	CH ₂ CH ₂ CH(COOH)NH ₂	28
NH ₂	(\pm)	CH ₃	D	CH ₂ CH ₂ CH(COOH)NH ₂	29
NH ₂	(\pm)	CH ₃	DL	CH ₂ CH ₂ CH(COOH)NH ₂	29
NH ₂	(\pm)	CH ₃	DL	CH ₂ CH ₂ C(CH ₃)(COOH)NH ₂	29

^aConfiguration at sulfonium center. ^bConfiguration at alpha carbon.

Zappia et al.³⁰ have investigated the activity of the sulfonium diastereomers of SAM with respect to the enzymes imidazole N-methyltransferase, hydroxyindole O-methyltransferase, S-adenosyl-L-methionine: homocysteine S-methyltransferase and S-adenosyl-L-methionine decarboxylase. The activity of (+)SAM and rate of reaction was shown to be half that of (-)SAM with respect to N- and O-methylations. In contrast, both diastereomers were effective as methyl donors in the methylation of homocysteine which proceeded more rapidly in the presence of (+)SAM than in the presence of (-)SAM alone. Only (-)SAM was subject to enzymatic decarboxylation. The activity of both diastereomers in the methylation of homocysteine prompted Zappia et al. to warn against generalization regarding the sulfonium configuration of SAM and activity. Borchardt and Wu³¹ have recently continued these investigations. For the transmethylation catalyzed by catechol O-methyltransferase, phenylethanolamine N-methyltransferase, histamine N-methyltransferase and hydroxyindole O-methyltransferase, only (-)SAM was active as a methyl donor, whereas, (+)SAM was shown to be a potent inhibitor of each of these transmethylation reactions.

S-adenosyl-L-methionine: homocysteine S-methyltransferase (HSMT) from Saccharomyces cerevisiae is unique among the enzymes surveyed in that it utilizes (+)SAM as a methyl donor. Zappia et al. have suggested that the utilization of (+)SAM may be related to the limited specificity of this enzyme which can also employ an achiral sulfonium compound, S-methyl-L-methionine, as methyl donor. Kjaer et al.³² have

demonstrated by the use of isotopically labeled S-methyl-L-methionine that the methylation of homocysteine catalyzed by the HSMT from jack bean meal proceeds with greater than 90% specificity for the pro-R sulfonium methyl group. Although the HSMTs from jack bean meal and yeast differ in many aspects,³³ the ability of the yeast enzyme to utilize S-methyl-L-methionine is not evidence that the enzyme lacks specificity for the sulfonium diastereomers of S-adenosyl-L-methionine.

The transmethylation of L-homocysteine by S-methyl-L-methionine was first reported by Shapiro³⁴ who subsequently detected the analogous reaction involving S-adenosyl-L-methionine.³⁵ Whereas dimethylacetothetin and dimethylpropiothetin, Figure 3, are active as methyl donors for the enzyme from mammalian liver, they exhibit no activity with cell-free extracts of Saccharomyces cerevisiae, Torulopsis utilis, Aerobacter aerogenes or Escherichia coli.³⁶ S-methyl-L-methionine and S-adenosyl-L-methionine exhibit equivalent activity as methyl donors in these microbial systems.³⁷ Shapiro and Yphantis³⁸ have demonstrated that the transmethylases of microbial origin are metalloenzymes.

FIGURE 3. Dimethylacetothetin and Dimethylpropiothetin

Shapiro et al.³⁹ have purified the HSMT from Saccharomyces cerevisiae approximately 500-fold by the combination of ethanol fractionation, DEAE cellulose ion exchange chromatography and Sephadex G75 gel filtration.

Shapiro et al.⁴⁰ then employed the purified enzyme in an investigation of substrate specificity which revealed that whereas either S-methyl-L-methionine or S-adenosyl-L-methionine will serve as methyl donor, only D- or L-homocysteine will serve as methyl acceptor. S-adenosyl-L-ethionine can replace the methyl donor, resulting in the biosynthesis of L-ethionine. Product inhibition studies revealed that both L-methionine and S-adenosyl-L-homocysteine were potent inhibitors as were the methyl and ethyl esters of L-methionine and N-hydroxymethyl-DL-methionine. L-homocysteine serves as both substrate and disulfide reducing reagent for the enzyme, although this latter activity can be replaced by 2-mercaptoethanol and other disulfide reducing reagents. Kinetic studies in which the order of addition of substrates was investigated have led to the proposal of a mechanistic scheme involving an ordered binding in which L-homocysteine is the first substrate bound and L-methionine the last product released. Sedimentation studies place the molecular weight of the enzyme at approximately 30,000.

Calorimetric measurements have revealed that the enzymatic transfer of the sulfonium methyl group from SAM or S-methyl-L-methionine to homocysteine is highly exothermic. Mudd et al.⁴¹ report that the S-methyl-L-methionine dependent transmethylation involves an enthalpy change of 8.0 ± 0.2

kcal/mole, whereas, the S-adenosyl-L-methionine dependent transmethylation involves an enthalpy change of 15.6 ± 0.5 kcal/mole. The authors have suggested that differential hydration may play an important role in explaining the variation observed for the methyl donors.

NMR spectroscopy has provided incontrovertible evidence that (+)SAM is a significant constituent of commercial preparations of S-adenosyl-L-methionine of high purity (>90%). An examination of the preparative schemes and the reported stability of SAM suggest that the (+)SAM is of biological origin. This poses the question of what biological role (+)SAM may play. SAM dependent transmethylation reactions are stereospecific, utilizing (-)SAM exclusively. The only reported exception is the methylation of homocysteine which employs either (-)SAM or (+)SAM, and proceeds more rapidly in the presence of (+)SAM. The interrelationships of the enzymes governing intracellular levels of L-methionine, S-adenosyl-L-methionine, S-adenosyl-L-homocysteine and L-homocysteine are illustrated in Figure 4. De La Haba and Cantoni¹⁶ report that the equilibrium for the reaction of adenosine and L-homocysteine, catalyzed by the adenosylhomocysteinase from mammalian liver, lies far in the direction of condensation. S-adenosyl-L-homocysteine will be hydrolyzed by this enzyme, however, if the products of the reaction are removed enzymatically. Consequently, the activity of HSMT serves to regulate the intracellular level of S-adenosyl-L-homocysteine, which in turn regulates SAM dependent transmethylation by feedback inhibition. Ferro and Spence⁴²

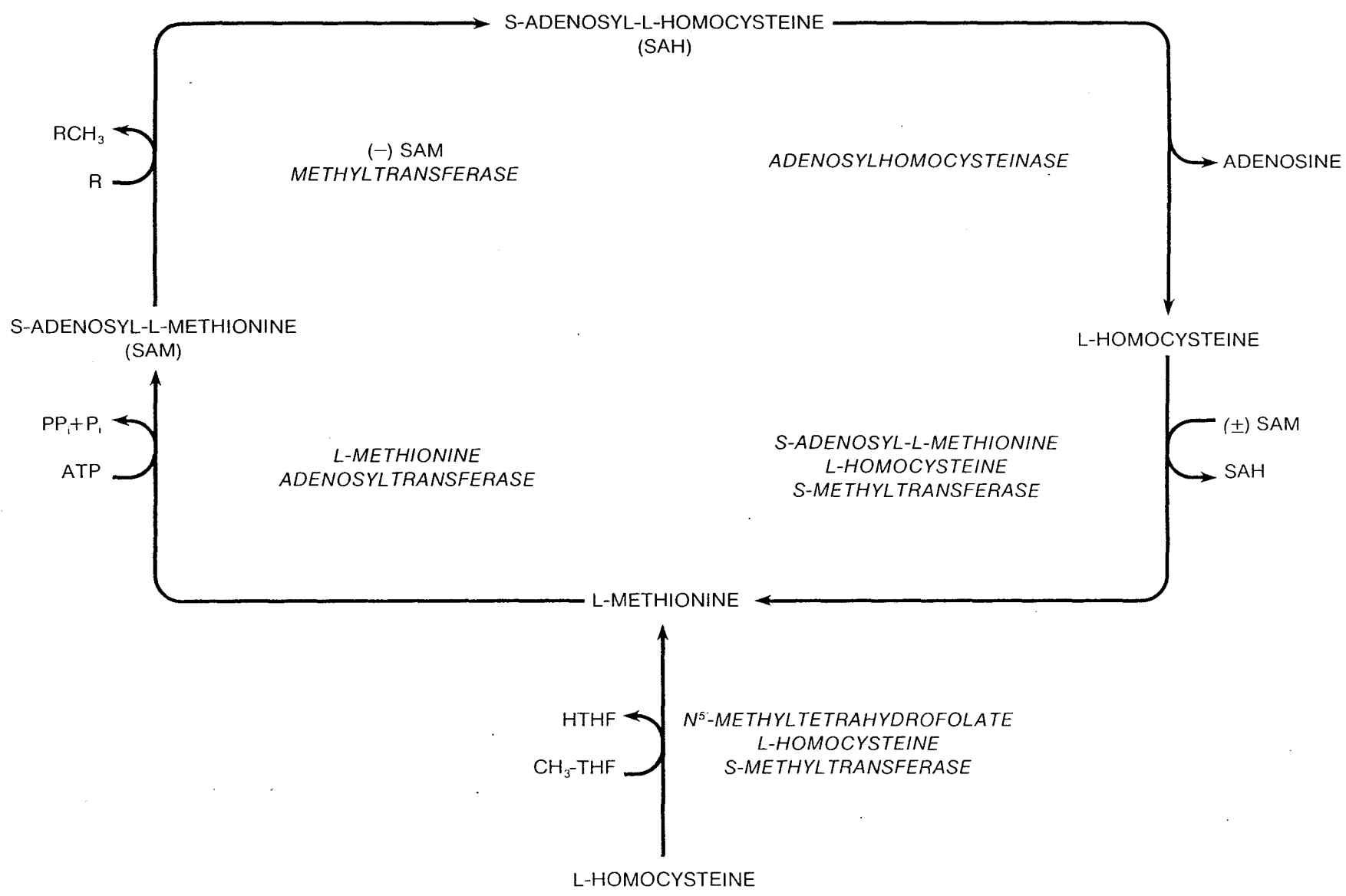

biosynthetic enzymes and the methionine adenosyltransferase from Saccharomyces cerevisiae are repressed by high intracellular levels of S-adenosyl-L-methionine. Accompanying the repression of these enzymes is the induction of HSMT, suggesting that this enzyme may play a key role in the regulation of S-adenosyl-L-methionine and L-methionine synthesis and balance. The cyclic interconversion of SAM, SAH, L-homocysteine and L-methionine requires the insured availability of a source of SAM for the methylation of L-homocysteine. Yet HSMT must compete with the myriad of other methyltransferases for the available SAM. If, however, nature insures the activity of HSMT by providing (+)SAM for its exclusive use, the constant availability of L-methionine or (-)SAM would be insured by a biosynthetic route independent of the N⁵-methyltetrahydrofolate mediated biosynthesis of L-methionine.

To explore this possibility we have developed an improved procedure for the purification of HSMT. It is hoped that the observations described herein will provide the basis for an investigation of enzymatic transmethylation in which the fate of the sulfonium diastereomers of S-adenosyl-L-methionine is directly observable by NMR spectroscopy.

MATERIALS AND METHODS

Materials

S-adenosyl-L-homocysteine, DL-homocysteine thiolactone hydrochloride, S-methyl-L-methionine iodide, (-)S-adenosyl-L-methionine chloride, L-methionine, L-methionine methyl ester, S-adenosyl-L-ethionine iodide and 5'-deoxy-5'-methylthioadenosine were purchased from Sigma Chemical Co., St. Louis, MO. (+)S-adenosyl-L-methionine iodide, 5'-deoxy-5'-dimethylthioadenosine iodide and S-methyl-L-methionine iodide methyl ester were prepared by reaction of the corresponding thioethers with methyl iodide in formic and acetic acids as described by De La Haba *et al.*²⁶ (+)S-adenosyl-L-(¹³CH₃S)-methionine iodide was similarly prepared by reaction with ¹³CH₃I. Sephadex G25, DEAE Sephadex A50 and AH-Sepharose 4B were purchased from Pharmacia Fine Chemicals, Piscataway, NJ. Spectraphor 1 membrane tubing was purchased from Spectrum Medical Industries Inc., Los Angeles, CA. Bio-phore 7.5% Precast Polyacrylamide Gels, SDS-PAGE Low Molecular Weight Standards, Protein Assay Dye Reagent Concentrate and Protein Assay Standard I were purchased from Bio-rad Laboratories, Richmond, CA. Adenosine Deaminase (EC. 3.5.4.4) was purified from Sanzyme, a preparation of Aspergillus oryzae purchased from Calbiochem-Behring Corp., La Jolla, CA. The deaminase was purified approximately 200-fold by fractionation with acetone and ethanol as described by Sharpless and Wolfenden.⁴³ Saccharomyces cerevisiae was purchased as

bakers' yeast cakes from Anheuser Busch, St. Louis, MO.

Spectroscopic Methods

^1H NMR spectra at 25°C were obtained on a Nicolet 360 MHz FTNMR spectrometer and on a Bruker HXS-360 spectrometer. The free induction decays, with up to 16 K points, were apodized by exponential multiplication prior to Fourier transformation, and the final spectra were base-line corrected. The residual water line was suppressed from the spectra by progressive saturation of the water.⁴⁴ Computer simulations of the five and six spin systems by the LOACN3 algorithm,⁴⁵ and least squares iteration converged with the observed spectral lines within an RMS deviation of 0.03. ^1H chemical shifts were measured versus internal TSP, sodium 3-(trimethylsilyl)-tetradeutero propionate. ^{13}C NMR spectra were obtained on a Nicolet 200 MHz FTNMR spectrometer operating at 50.3 MHz and digitizing free induction decays as 16 K points. ^{13}C spin lattice relaxation times (T_1) were measured using a 180° - t - 90° inversion recovery technique where t is the time interval between 180° and 90° pulses.⁴⁶ Routine samples for spectroscopic study were twice lyophilized from $^2\text{H}_2\text{O}$ with the final concentration adjusted to 0.025 M. The pD ($\text{pD} = \text{pH} + 0.4$)⁴⁷ was adjusted to 3.4 by the dropwise addition of 10% ^2HCl .

Enzyme and Protein Assays

The activity of S-adenosyl-L-methionine: Homocysteine S-methyltransferase (HSMT) can be assayed by independent procedures for the determination of each of the reaction

products. Methionine was determined colorimetrically by reaction with sodium nitroprusside, whereas, S-adenosyl-L-homocysteine was determined by enzymatic deamination of the purine ring and spectroscopic quantitation of the resulting inosyl derivative. The methionine assay allowed for several simultaneous determinations but offered limited sensitivity. Consequently, it was employed exclusively for the detection of enzymatic activity in chromatographic fractions. Spectroscopic determination of S-inosyl-L-homocysteine offered the detection of nanomolar quantities and was routinely employed to determine the specific activity of purified enzyme preparations. The concurrent use of two interrelated assays confirmed that S-adenosyl-L-methionine consumed in the activity studies resulted in the biosynthesis of methionine.

Methionine Assay. McCarthy and Sullivan⁴⁸ first employed the reaction of sodium nitroprusside ($\text{Na}_2\text{Fe}(\text{CN})_5\text{NO}$) with methionine for the colorimetric determination of methionine. This reaction has found wide use in the analysis of protein hydrolysates.⁴⁹ The exact nature of the resulting chromophore is presently unknown, but its absorbance spectrum is illustrated in Figure 5. Compounds interfering with the nitroprusside reaction were first removed by precipitation as described by Shapiro,⁵⁰ which included deproteination by the addition of perchloric acid,⁵¹ removal of S-adenosyl-L-methionine or S-methyl-L-methionine by the addition of phosphotungstic acid⁵² and removal of DL-homocysteine by the addition of p-chloromercuribenzoic acid.⁵³ Attempts to detect methionine in the presence of the disulfide reducing reagents

disulfide reducing reagents 2-mercaptoethanol or dithiothreitol resulted in interference. Consequently, L-cysteine was substituted as a disulfide reducing reagent and the amount of p-chloromercuribenzoic acid increased to yield the quantitative precipitation of both DL-homocysteine and L-cysteine.

Micro-centrifuge test tubes (1.5 mL) containing 0.2 mL 0.2 M Na⁺ phosphate buffer (pH 6.8), 0.1 mL 0.001 M ZnSO₄, 0.1 mL 0.06 M L-cysteine, 0.2 mL 40 mM DL-homocysteine and 0.2 mL enzyme solution were preincubated for 15 min. at 37°C. DL-homocysteine was freshly prepared from the corresponding thiolactone by reaction with 0.3 N NaOH followed by neutralization with 0.3 M NaH₂PO₄. The enzymatic reaction was initiated by the addition of 0.2 mL 20 mM S-methyl-L-methionine or S-adenosyl-L-methionine and the solution incubated for one to eight hours. Control experiments contained all reagents except the methyl donor and were adjusted to a volume of 1 mL by the addition of 0.2 mL 0.1 M Na⁺ phosphate buffer (pH 6.8). The enzymatic reaction was terminated by the addition of 0.2 mL 54% perchloric acid, 0.2 mL 30% phosphotungstic acid and 0.1 mL 0.16 M p-chloromercuribenzoic acid. Precipitates were removed by centrifugation at 15,000 x g for 30 min. The colorless supernatant liquid (1 mL) was transferred to a 13 mm x 100 mm test tube containing 1 mL 0.5 N NaOH and 0.5 mL sodium nitroprusside, heated for 10 min at 37°C then cooled on ice to room temperature. To the bright yellow solution was added 1.3 mL 6 N HCl and the test tube was allowed to stand for exactly 15

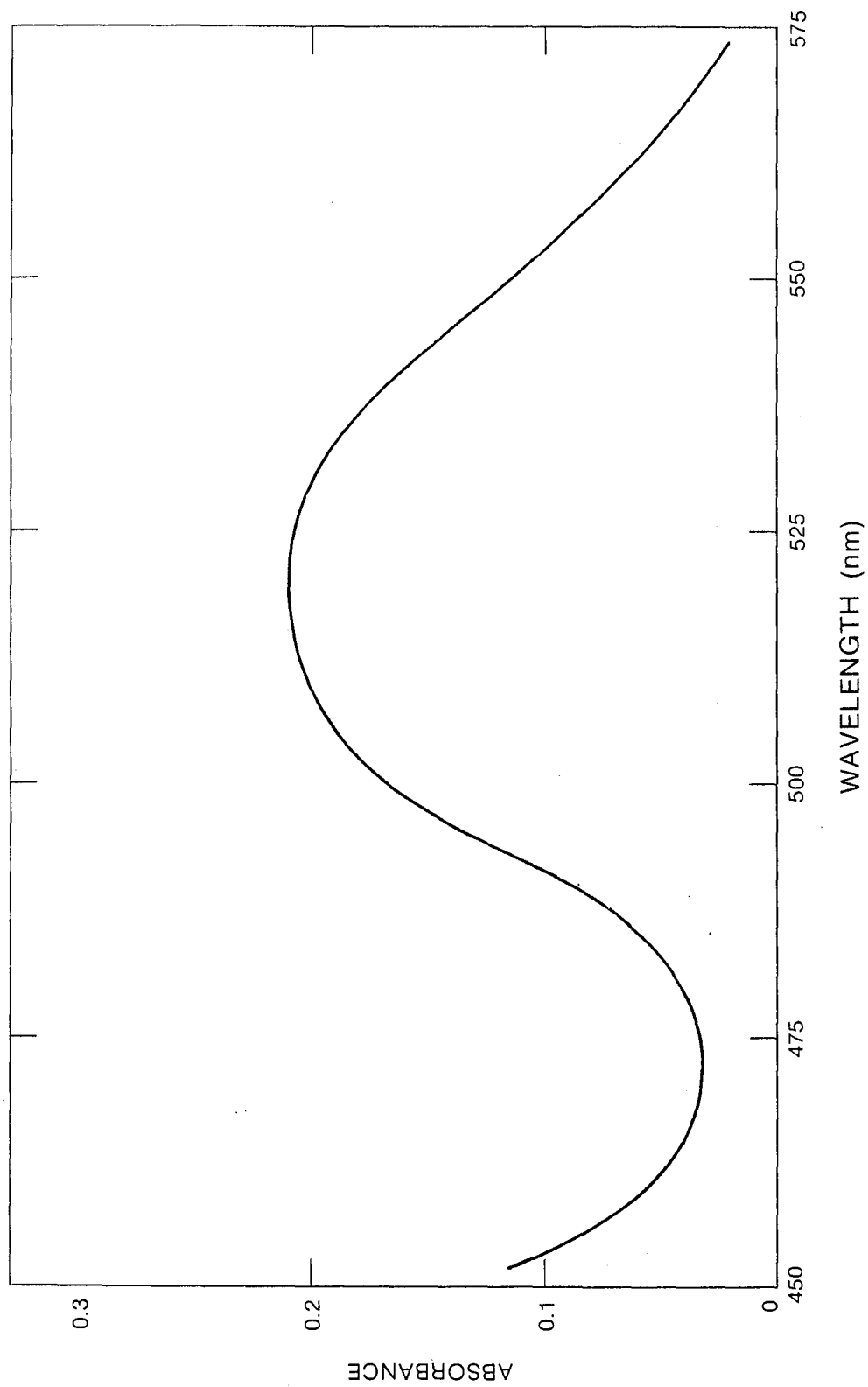

FIGURE 5. Absorbance Spectrum of Sodium Nitroprusside-Methionine Adduct.

min. while the red color associated with methionine formed. The test tube was then placed in a Bausch and Lomb Spectronic 20 spectrometer and the absorbance at 515 nm recorded. Methionine was determined from a standard curve which was linear over the concentration range 0.2 to 6 mM, Figure 6.

S-Adenosyl-L-homocysteine Assay. The specific activity of purified enzyme preparations was determined spectroscopically as described by Schlenk and Zydek.⁵⁴ The progress of transmethylation was monitored by enzymatic deamination of S-adenosyl-L-homocysteine, formed from S-adenosyl-L-methionine, and quantitation of the inosine derivation at 265 nm. The absorbance spectra of S-adenosyl-L-homocysteine and S-inosyl-L-homocysteine are illustrated in Figure 7. For each decrease of 0.1 absorbance units at 265 nm, 11.6 nanomoles of S-adenosyl-L-homocysteine have been deaminated. Deamination results from the action of the nonspecific Adenosine Deaminase from Aspergillus oryzae which proceeds at a rate at least 100-fold greater than that of the transmethylation reaction.

To a 1 cm spectrophotometer cell was added 2.2 mL of a cocktail reagent containing 0.25 μ mole Na^+ phosphate buffer (pH 6.8), 0.05 μ mole ZnSO_4 and 3 μ moles dithiothreitol. DL-homocysteine was freshly prepared as described above and 3.6 μ moles added in a volume of 0.2 mL. Purified adenosine deaminase (20-30 μ g) was added in a volume of 0.2 mL along with 0.2 mL of a solution of HSMT containing approximately 0.5 mg/mL protein. The transmethylation reaction was initiated by the addition of 0.36 μ mole S-adenosyl-L-

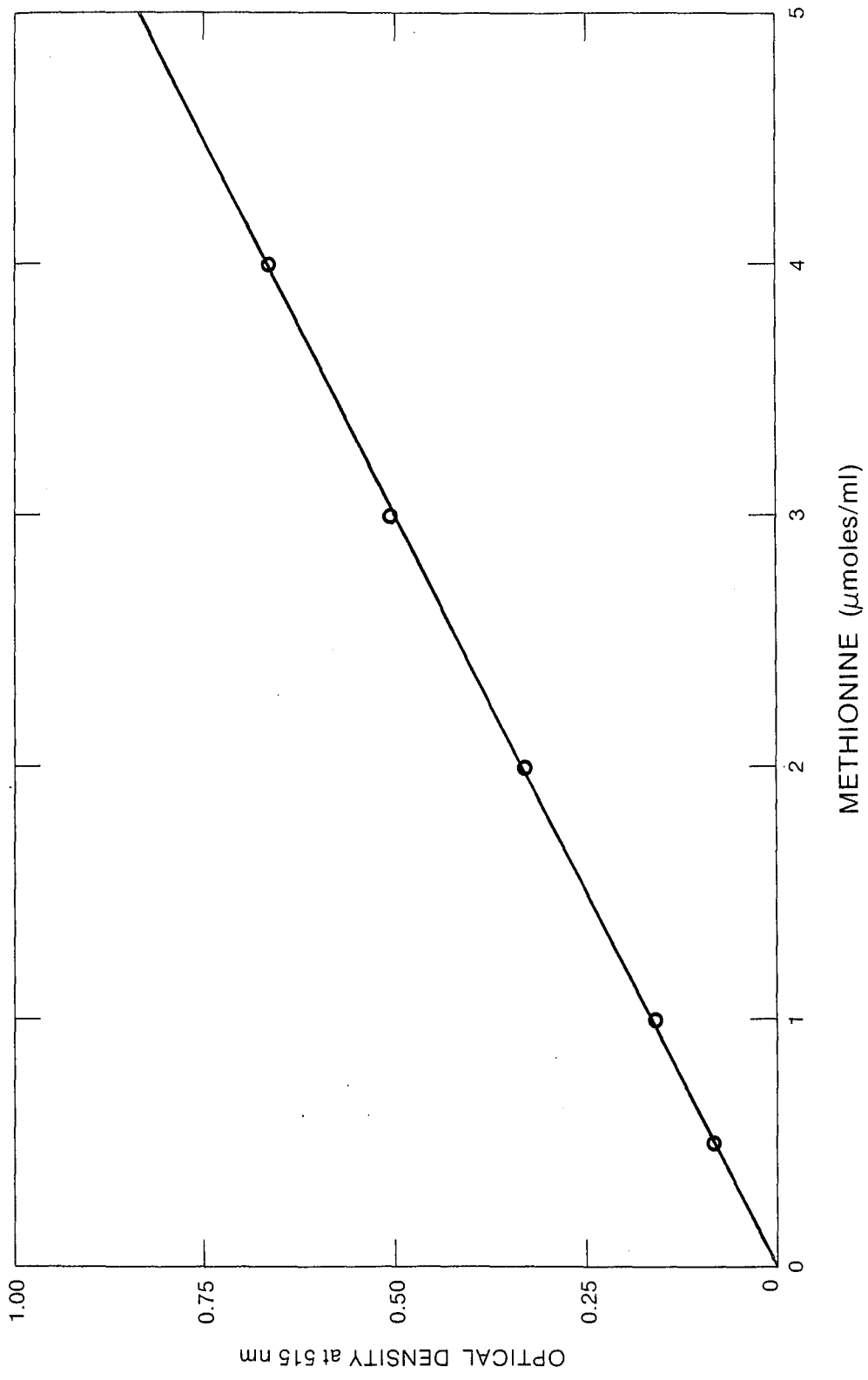

FIGURE 6. Methionine Standard Curve

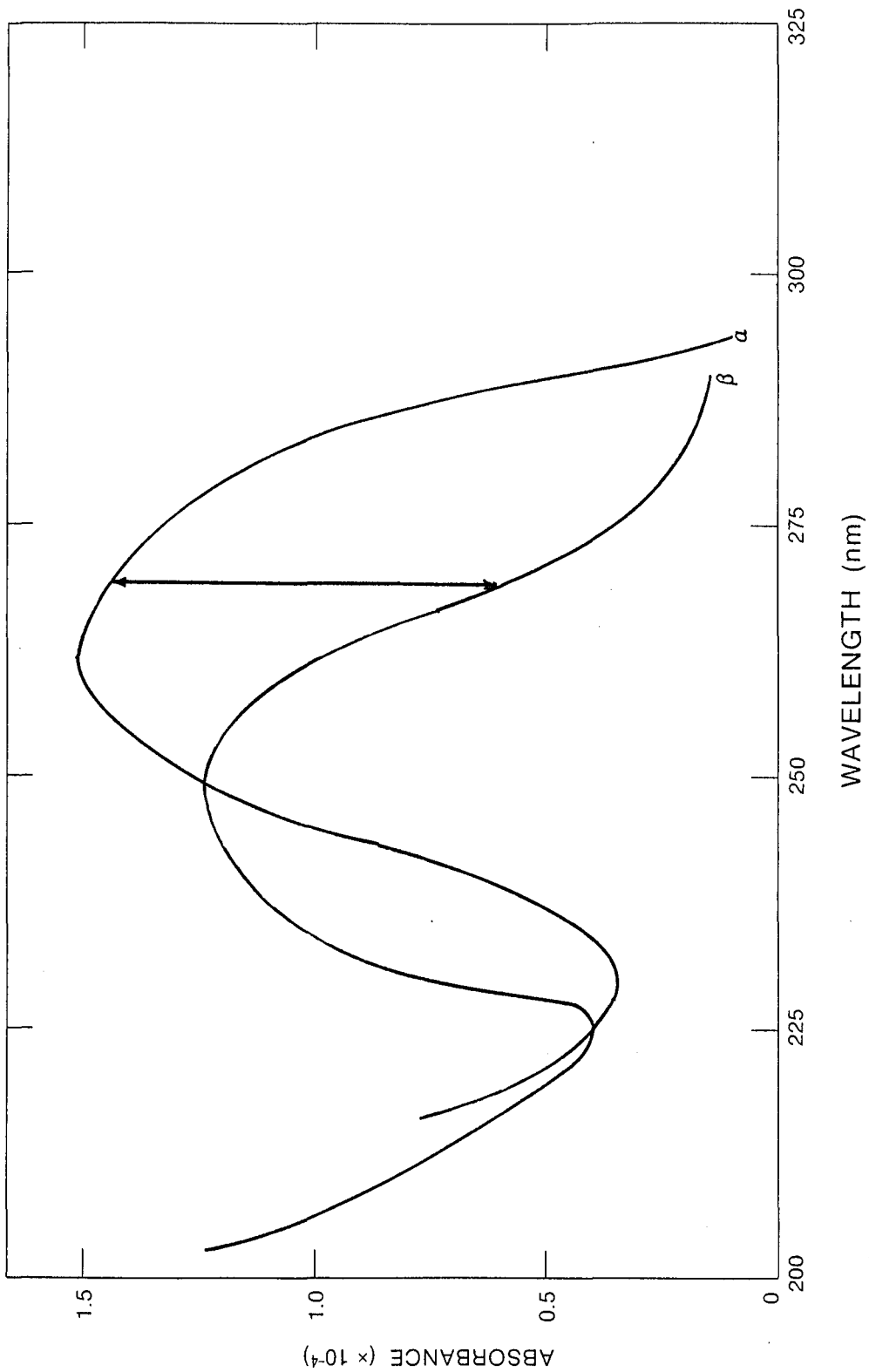

FIGURE 7. Absorbance Spectra of S-Adenosyl-L-homocysteine^a and S-Inosyl-L-homocysteine^b.

methionine in a volume of 0.2 mL and the course of the reaction monitored at 265 nm with a Cary 219 spectrophotometer at 25°C, Figure 8.

One unit of enzyme activity was defined as the amount of enzyme catalyzing the synthesis of 1.0 μ mole of S-adenosyl-L-homocysteine or DL-methionine per hour under the reaction conditions described above. Protein was determined by the dye-binding method of Bradford,⁵⁵ with gamma-globulin as the reference standard.

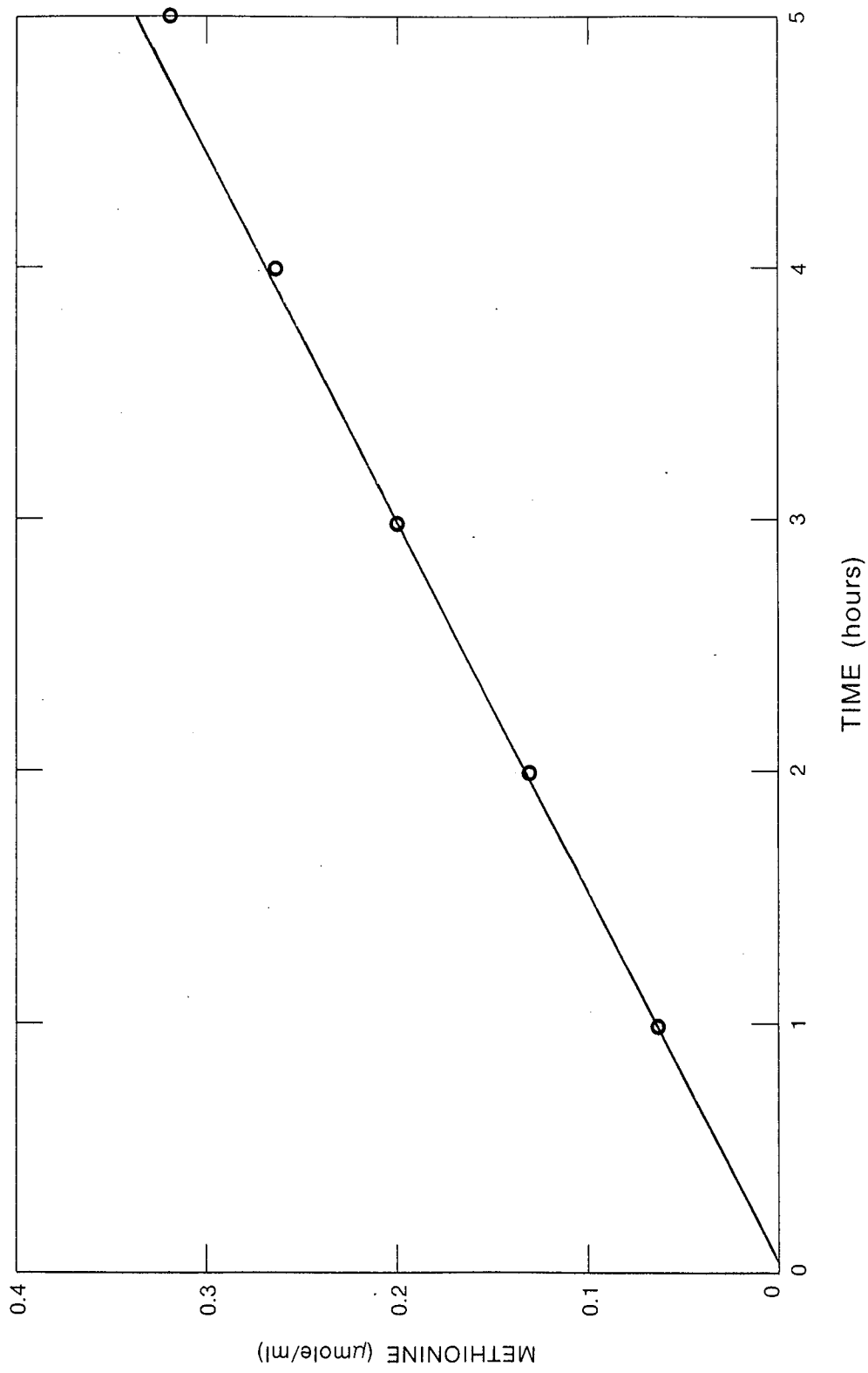

FIGURE 8. The Transmethylation of Homocysteine as Monitored by the Production of S-Inosyl-L-homocysteine.

Purification of HSMT

The purification of HSMT is summarized as follows: A cytoplasmic extract was first obtained by incubation in the presence of toluene followed by the removal of cellular debris by centrifugation. To the cytoplasmic extract was added solid ammonium sulfate. Protein precipitating between 60% and 85% ammonium sulfate saturation was collected, suspended in buffer and desalted by gel exclusion chromatography. Ion exchange chromatography was next employed and protein exhibiting no affinity for the cationic gel discarded. Finally, the ion-exchange fraction was freed from salt by dialysis and was purified by affinity chromatography. The course of the purification was monitored by isoelectric focusing and SDS gel electrophoresis.

Toluene Extraction. Cell-free extracts of Saccharomyces cerevisiae were obtained by toluene extraction as described by Shapiro et al.⁴⁰ Refrigerated bakers' yeast cakes (500g) were suspended in 250 mL distilled water and heated in a water bath to 37° C. To the cell suspension was added 32.6 g NaHCO₃ and 88 mL toluene. The suspension was incubated for 1.5 hours while shaking at 150 r.p.m. The resulting cytoplasmic extract was removed from the water bath and an equal volume of cold water added. Cellular debris was removed by centrifugation at 5,000 x g for 30 min. and the supernatant fluid filtered through four layers of cheesecloth. The supernatant fluid was then centrifuged at 15,000 x g for 30 min. and filtered as described above. The resulting solution was collected and stored frozen at -15°C for up to 6 months.

Ammonium Sulfate Precipitation. An aliquot of the frozen solution was allowed to thaw overnight in a cold room at 40C where all subsequent fractionation steps were performed. To the solution was added $(\text{NH}_4)_2\text{SO}_4$ (361 g) to afford a 60% saturated solution which was shaken at 150 r.p.m. for 30 min. The resulting suspension was clarified by centrifugation at 20,000 x g for 30 min. and the supernatant fluid filtered through four layers of cheesecloth. To the supernatant fluid was added $(\text{NH}_4)_2\text{SO}_4$ (164 g) to yield an 85% saturated solution. The suspension was again shaken at 150 r.p.m. for 30 min. Protein precipitate was collected by centrifugation at 20,000 x g for 30 min. The precipitate was dissolved in 40 mL 0.02 M Na^+ phosphate buffer (pH 6.8) containing 10% propylene glycol as an anti-foaming agent and desalted by gel exclusion chromatography.

Sephadex G25 Gel Exclusion Chromatography. Sephadex G25 medium (15.4 g) was suspended in 75 mL of 0.02 M Na^+ phosphate buffer (pH 6.8) and kept at room temperature for 30 min. The slurry was added to a 1.6 cm x 40 cm column and the gel equilibrated by the addition of 1 L 0.02 M Na^+ phosphate buffer (pH 6.8) from a mariotte flask suspended at a height of 80 cm above the column.

The protein solution obtained from the ammonium sulfate precipitation was divided into three fractions of equal volume and each applied to the column from a sample applicator attached through a 3-way valve to the column inlet line. The sample was applied from a height of 80 cm at a rate of 2.6 mL/min. The active protein was eluted from the column at

a rate of 3.5 mL/min. by the addition of 0.02 M Na⁺ phosphate buffer (pH 6.8) and collected in a volume approximately twice that of the sample. The column was then washed with additional buffer and the next sample applied when the absorbance of the effluent was less than 0.001. A volume of 125 mL was obtained on combining the active protein fractions.

DEAE Sephadex A50 Ion-Exchange Chromatography. DEAE Sephadex A50 (15 g) was suspended in 1 L of 0.02 M Na⁺ phosphate buffer (pH 6.8) and heated in an oven at 90°C for 3 hours. The gel was then allowed to cool overnight at 4°C and the fines removed by aspiration. A lower flow adapter was fitted in a column of 5 cm diameter and sufficient gel added to provide a settled bed height of 20 cm. The column was fitted with an upper flow adapter and the gel equilibrated by the addition of 4 L 0.02 M Na⁺ phosphate buffer (pH 6.8).

The fraction obtained by gel exclusion chromatography was added to the column from a sample applicator at a rate of 1.6 mL/min. Nonbonding protein was eluted by the addition of 600 mL 0.02 M Na⁺ phosphate buffer (pH 6.8) at a rate of 2.4 mL/min. Fractions were collected at 8 min. intervals as the active protein was eluted by the addition of 800 mL 0.2 M Na⁺ phosphate buffer (pH 6.8). The column was regenerated by equilibration with 0.5 L 0.5 M Na⁺ phosphate buffer (pH 6.8) followed by 1 L 0.02 M Na⁺ phosphate buffer (pH 6.8). Those fractions exhibiting detectable activity by the nitroprusside assay after 1 hour of incubation were pooled and dialyzed overnight against 5 L of 0.01 M Na⁺ phosphate buffer (pH 6.8) and yielded a volume of 130 mL.

L-Methionine AH-Sepharose 4B Affinity Chromatography.

AH-Sepharose 4B (5.0 g) was deposited in a sintered glass funnel, suspended in excess 0.5 M NaCl and washed with 1 L 0.5 M NaCl followed by 0.5 L distilled water. The gel was allowed to settle for 30 min. in water after which excess water was removed by aspiration. A solution of L-methionine (0.15 g) in 40 mL distilled water was added to the gel to yield a slurry containing three parts liquid and one part gel. To the slurry was added 0.2 g of finely powdered 1-ethyl-3-(3-dimethylaminopropyl) carbodiimide hydrochloride. The pH was adjusted to 4.5 by the slow addition of 10% HCl. The slurry was placed on a rotary shaker at 150 r.p.m. for 24 hours. The resulting gel was transferred to a sintered glass funnel and washed successively with 0.5 L of 0.1 M Tris HCl-1 M NaCl buffer (pH 8.3) and 0.1 M Na⁺ citrate-1 M NaCl buffer (pH 4.7), each in 100 mL aliquots. The gel was finally washed with 0.5 L distilled water, suspended in 50 mL 0.02 M Na⁺ phosphate-0.05 M NaCl buffer (pH 7.0) and added to a 0.9 cm x 30 cm column. A mariotte flask was attached at a height of 80 cm and the gel equilibrated with 1 L 0.02 M Na⁺ phosphate buffer-0.05 M NaCl buffer (pH 7.0). The gel contained approximately 160 μ moles of L-methionine bound through the α -carboxyl group by formation of an amide bond with the amino group of AH-Sepharose 4B.

The dialyzed protein solution obtained from the DEAE Sephadex chromatography was divided into three samples of equal volume and each sample was added to the column from a sample applicator at a rate of 2.0 mL/min. Protein

exhibiting no affinity for the gel bound ligand was eluted with 200 mL 0.02 M Na⁺ phosphate-0.05 M NaCl buffer (pH 7.0). Fractions were collected at 3 min. intervals as ligand bound proteins were eluted by the application of a NaCl gradient prepared by the addition of 250 mL 0.02 M Na⁺ phosphate-0.05 M NaCl buffer (pH 7.0) to 250 mL 0.02 M Na⁺ phosphate-0.4 M NaCl buffer (pH 7.0). The gradient was prepared at a rate of 2.0 mL/min. in a constant volume mixing chamber which was suspended at a height of 80 cm above the column. The active protein was confined to the fourth peak eluted. The column was regenerated by equilibration with 250 mL 0.02 M Na⁺ phosphate-0.05 M NaCl buffer (pH 7.0). Fractions exhibiting activity by the nitroprusside assay after 8 hours of incubation were pooled and dialyzed overnight against 5 L 0.005 M Na⁺ phosphate buffer (pH 7.0) and yielded a volume of 120 mL. To preserve enzymatic activity the dialyzed sample was lyophilized and stored at -15°C.

Isoelectric Focusing in Polyacrylamide Gels. A monomer stock solution containing 73.12 g acrylamide and 1.875 g methylene-bis-acrylamide in 250 mL distilled water was prepared and stored in an amber bottle at 4°C. To 6.25 mL of the monomer stock solution contained in a 25 mL volumetric flask on ice was added 1.25 g glycerol, 10 mL distilled water and 1.25 mL Bio-Lyte 3/10. After mixing, 0.5 mL 0.02% riboflavin solution was added and the volume contained in the flask adjusted to 25 mL by the addition of distilled water. To each of eight 5.5 mm x 125 mm glass tubes was added approximately 2.5 mL of the gel solution. The contents of

each tube was overlaid with water, placed in a vertical position and polymerized overnight by UV irradiation.

Samples containing 10 to 50 mg protein were prepared as 25% sucrose solutions and 100 μ L aliquots applied to the drained surface of each polymerized gel. Each sample was overlaid with 100 μ L of 20% sucrose, 100 μ L of 10% sucrose and sufficient 0.06 N H_2SO_4 to fill each tube. The tubes were placed in an electrophoresis cell containing a lower electrolyte solution of 0.02 N $CaCO_3$ and 0.04 N NaOH. An upper electrolyte solution of 0.06 N H_2SO_4 was added and electrophoresis conducted at 210 V for 20 hours with the anode in the upper reservoir.

The gels were stained 4 hours in 0.04% Coomassie Brilliant Blue R-250, 0.05% Crocein Scarlet and 0.5% $CuSO_4$ in 10% acetic acid-27% isopropanol and destained by diffusion for 2 hours in 0.5% $CuSO_4$ in 7% acetic acid-12% isopropanol followed by 12 hours in 7% acetic acid-12% isopropanol.

SDS Polyacrylamide Gel Electrophoresis. Bio-phore 7.5% precast polyacrylamide gels (0.5 x 125 mm) were prepared by electrophoretic buffer induction for 8 hours at 4 ma/tube in a running buffer containing 0.1% SDS and 0.041 M Tris-0.041 M acetic acid (pH 6.6). The gels were stored at 4° C for up to one month prior to use. Samples were prepared by reconstitution of salt free lyophilized preparations and adjusted to approximately 20 mg/mL protein by 1:1 dilution with a sample buffer containing 1% SDS, 0.04 M dithiothreitol, 0.001 M EDTA and 0.041 M Tris-0.041 M acetic acid buffer (pH 6.6) and the disulfide bonds reduced by heating at

10 μ L of Bio-phore basic tracking dye and a 25 μ L aliquot was applied to the gel. Electrophoresis was conducted at 4 ma/tube for one hour followed by 6 ma/tube until the tracking dye was 1 cm from the bottom of the gel. Gels were stained overnight in 0.05% Coomassie Brilliant Blue R-250 in 10% acetic acid-10% isopropanol and destained by diffusion in 10% acetic acid-10% isopropanol.

For molecular weight determination Bio-phore SDS-PAGE low molecular weight standards were prepared by 20:1 dilution with sample buffer and the disulfide bonds reduced as described above. A 25 μ L sample was applied to each gel prior to electrophoresis, staining and destaining with accompanying SDS gels.

RESULTS AND DISCUSSION

NMR Spectroscopy of SAM and SAH⁵⁶

The proton resonances of SAM and SAH have been assigned unambiguously based on chemical shift values, spin multiplicities, decoupling experiments and direct comparison to the previously assigned spectra of the model compounds: adenosine, L-methionine, S-methyl-L-methionine iodide and 5'-deoxy-5'-dimethylthioadenosine iodide. All assignments have been confirmed by computer simulation to within an RMS deviation of 0.03. The chemical shifts and coupling constants for S-adenosyl-L-methionine iodide, S-methyl-L-methionine iodide and 5'-deoxy-5'-dimethylthioadenosine iodide are given in Table 6. The 360 MHz NMR spectrum and computer simulation of the methionine side chain of SAM appear in Figure 9. Although we have reported details of the NMR spectrum of SAM previously,⁵⁷ these experiments have been repeated on instrumentation offering an improved signal to noise ratio. The coupling constants obtained for model compounds structurally related to SAM are here reported for the first time. The chemical shifts and coupling constants for S-adenosyl-L-homocysteine, L-methionine and adenosine are given in Table 7 and the NMR spectrum and computer simulation of the homocysteine side chain of SAH appear in Figure 10. The following discussion deals first with the conformational information, provided by vicinal proton coupling constants, which permits a comparison between SAM and SAH, and second

TABLE 6. NMR Parameters for S-Adenosyl-L-methionine and Related Sulfonium Compounds

Chemical Shifts (δ , ppm)						
Compound	H α	H β	H γ	HSCH ₃	H5'5''	
SAM ^a	3.81	2.36	3.48 3.70	2.96 3.01	3.92 4.06	
MMet ^b	3.89	2.39	3.45 3.54	2.97	-	
DMTA ^c	-	-	-	2.92 2.94	3.79 3.85	
	H _{4'}	H _{3'}	H _{2'}	H _{1'}	H ₂	H ₈
a	4.60	4.86	4.97	6.12	8.27	8.29
b	-	-	-	-	-	-
c	4.48	4.52	4.84	6.05	8.26	8.28
Coupling Constants (J, Hz)						
Compound	³ J _{$\alpha\beta$}	³ J _{$a\beta$}	² J _{$\beta\beta$}	³ J _{$\beta\gamma$}	² J _{$\gamma\gamma$}	
SAM ^a	6.6	6.6	0	7.4	-11.2	
MMet ^b	6.5	6.5	0	8.7	-14.6	
DMTA ^c	-	-	-	-	-	
	³ J _{1'2'}	³ J _{2'3'}	³ J _{3'4'}	³ J _{4'5'}	³ J _{4'5''}	² J _{5'5''}
a	4.4	5.3	<0.5	9.5	2.4	-12.8
b	-	-	-	-	-	-
c	4.4	4.9	<0.5	8.8	3.1	-13.6

^aS-Adenosyl-L-methionine I⁻. ^bS-Methyl-L-methionine I⁻.
^c5'-Deoxy-5'-dimethylthioadenosine I⁻.

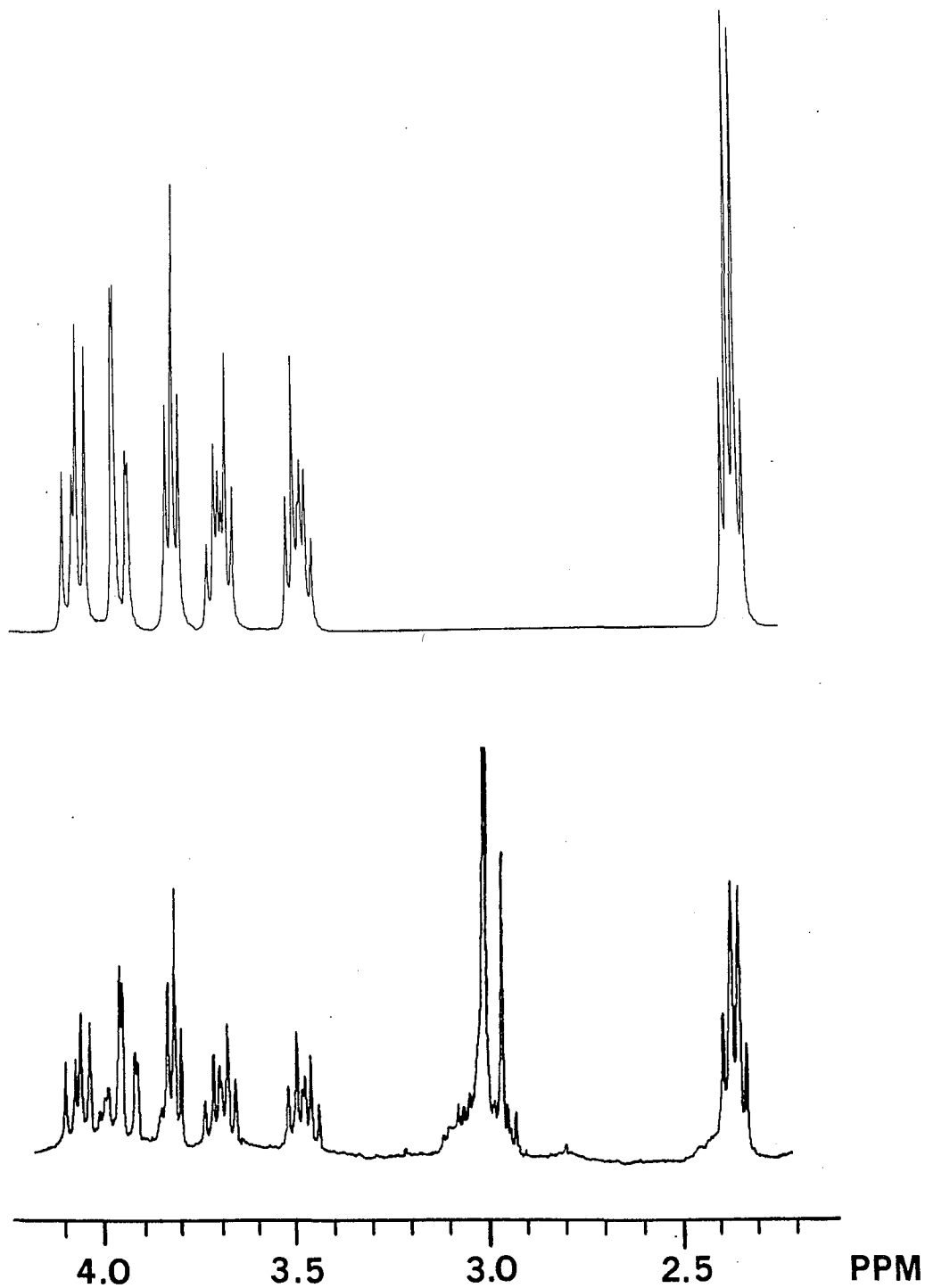

FIGURE 9. Below: NMR Spectrum of the Methionine Side Chain Region of SAM. Above: Computer Simulation of the Methionine Side Chain of SAM.

TABLE 7. NMR Parameters for S-Adenosyl-L-homocysteine and Related Thio-ethers

Chemical Shifts (δ , ppm)						
Compound	H α	H β	H γ	HSCCH $_3$	H5'5''	
SAH ^a	3.85	2.19	2.73	-	2.89 2.97	
Met ^b	3.87	2.13 2.21	2.65	2.14	-	
Adenosine ^c	-	-	-	-	3.83 3.91	
	H $_4'$	H $_3'$	H $_2'$	H $_1'$	H $_2$	H $_8$
a	4.38	4.45	4.87	6.09	8.25	8.35
b	-	-	-	-	-	-
c	4.32	4.44	4.80	6.04	8.19	8.30
Coupling Constants (J, Hz)						
Compound	$^3J_{\alpha\beta}$	$^3J_{\alpha\beta}$	$^2J_{\beta\beta}$	$^3J_{\beta\gamma}$	$^2J_{\gamma\gamma}$	
SAH ^a	4.7	6.8	-14.1	7.5	0	
Met ^b	5.3	6.9	-14.9	7.6	0	
Adenosine ^c	-	-	-	-	-	
	$^3J_{1'2'}$	$^3J_{2'3'}$	$^3J_{3'4'}$	$^3J_{4'5'}$	$^2J_{5'5''}$	
a	5.2	5.0	<0.5	4.9	6.4	-14.1
b	-	-	-	-	-	-
c	6.1	5.3	4.3	2.7	3.5	-12.9

^aS-Adenosyl-L-homocysteine. ^bL-Methionine. ^cAdenosine.

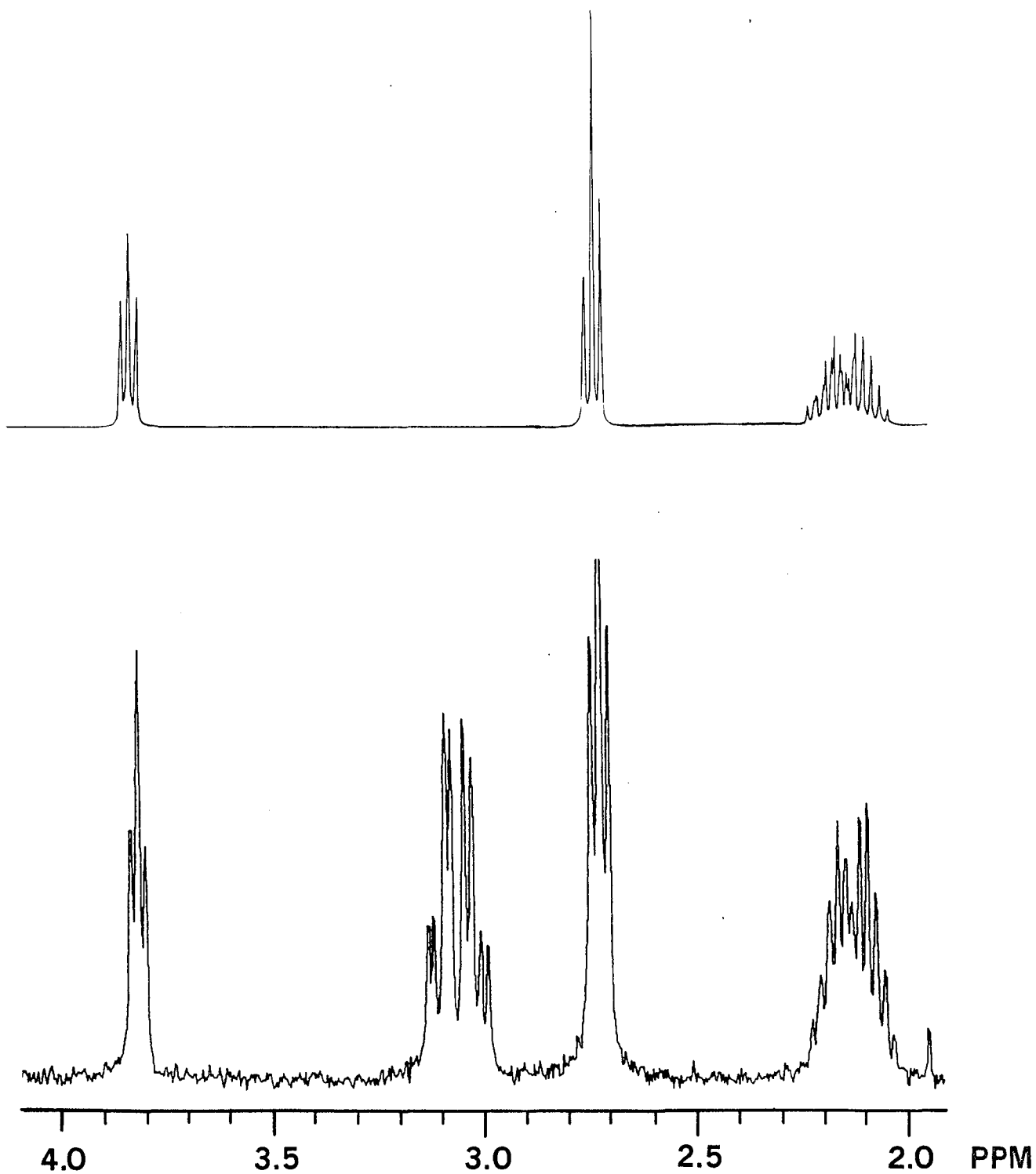

FIGURE 10. Below: NMR Spectrum of the Homocysteine Side Chain Region of SAH. Above: Computer Simulation of the Homocysteine Side Chain of SAH.

with the NMR evidence concerning the stereochemistry of the sulfonium methyl group of S-adenosyl-L-methionine.

Conformational Analysis of S-Adenosyl-L-methionine

The analysis of the conformational properties which result from the rotation about single bonds depends on relating observed vicinal coupling constants (3J) to the dihedral angles (θ) between vicinal nuclei using an appropriate Karplus-type relation,⁵⁸ equation (1).

$$^3J_{(HH)} = A\cos^2\theta - B\cos\theta + C \quad (1)$$

The various coefficients in equation (1) have been evaluated theoretically,^{59,60,61} but generally differ significantly from experimental values. Limitations of the Karplus relation arise from the dependence of vicinal coupling on molecular parameters including bond length, bond angle, electronegativity and the orientation of attached substituents.^{62,63} Consequently, parameters for equation (1) have been determined empirically from models of the various coupling paths. In principle, separate Karplus relations need to be determined for each molecular fragment before a proper analysis can be undertaken. However, a number of approximations^{64,65,66} suggest that the analysis of the ribofuranose ring requires only two sets of Karplus parameters, one for the sugar ring and one for the exocyclic group.

Conformation of the Ribofuranose Ring. Davies⁶⁷ has derived Karplus parameters appropriate to the furanose ring system from the pseudorotational⁶⁸ analysis of the coupling

constants obtained from 140 spectral analyses of nucleosides and nucleotides, equation (2).

$${}^3J_{(HH)} = 10.2\cos^2\theta - 0.8\cos\theta \quad (2)$$

In practice, investigators have attempted to fit the observed vicinal coupling constants to various models predicted for the furanose ring. In 1968, Smith and Jardetsky⁶⁹ derived approximate dihedral angles between vicinal protons ($\theta_{1'2'}$, $\theta_{2'3'}$, $\theta_{3'4'}$) for each of twenty symmetrical envelope and twist conformations of the furanose ring from molecular models, Table 8. The coupling constants which appear in Table 8 were calculated from equation (2), and differ from those proposed by Smith and Jardetsky.

When observed at 360 MHz, the ribose ring protons of SAM constitute a six-spin ABKMNX spectral system where A = H5'', B = H5', K = H4', M = H3', N = H2' and X = H1'. Only the H1', H2' interaction is first-order. The observed coupling constants are: ${}^3J_{1'2'} = 4.4$ Hz, ${}^3J_{2'3'} = 5.3$ Hz and ${}^3J_{3'4'} < 0.5$ Hz. Inspection of Table 8 reveals these results to be most consistent with the C3'-exo conformer, Figure 11. As authors have differed in their choice of dihedral angles employed to approximate the ribose ring conformers, considerable variations among theoretical estimates of coupling constants have appeared in the literature.^{70,71,72} The correlation of our data with the C3'-exo conformer remains firm, however, regardless of the source of theoretically predicted angles and couplings. The C3'-exo conformer has been detected crystallographically for certain nucleotides.⁷³

TABLE 8. Dihedral Angles and Calculated Coupling Constants
for Twenty Possible Conformations of D-Ribose
in Nucleosides and Nucleotides.

	$\theta_{1'2'}$	J	$\theta_{2'3'}$	J	$\theta_{3'4'}$	J
C(1')-endo	75	0.2	15	7.6	120	2.2
C(1')-exo	165	8.6	15	7.6	120	2.2
C(2')-endo	165	8.6	45	3.9	105	0.4
C(2')-exo	75	0.2	45	3.9	135	4.6
C(3')-endo	105	0.4	45	3.9	165	8.6
C(3')-exo	135	4.6	45	3.9	75	0.2
C(4')-endo	120	2.2	15	7.6	75	0.2
C(4')-exo	120	2.2	15	7.6	165	8.6
O-endo	135	4.6	0	8.2	135	4.6
O-exo	105	0.4	0	8.2	105	0.4
C(1')-endo-C(2')-exo	60	1.7	45	3.9	135	4.6
C(1')-exo-C(2')-endo	180	9.2	45	3.9	105	0.4
C(1')-endo-O-exo	75	0.2	15	7.6	105	0.4
C(1')-exo-O-endo	165	8.6	15	7.6	135	4.6
C(2')-endo-C(3')-exo	165	8.6	60	1.7	75	0.2
C(2')-exo-C(3')-endo	75	0.2	60	1.7	165	8.6
C(3')-endo-C(4')-exo	105	0.4	45	3.9	180	9.2
C(3')-exo-C(4')-endo	135	4.6	45	3.9	60	1.7
C(4')-endo-O-exo	105	0.4	15	7.6	75	0.2
C(4')-exo-O-endo	135	4.6	15	7.6	165	8.6

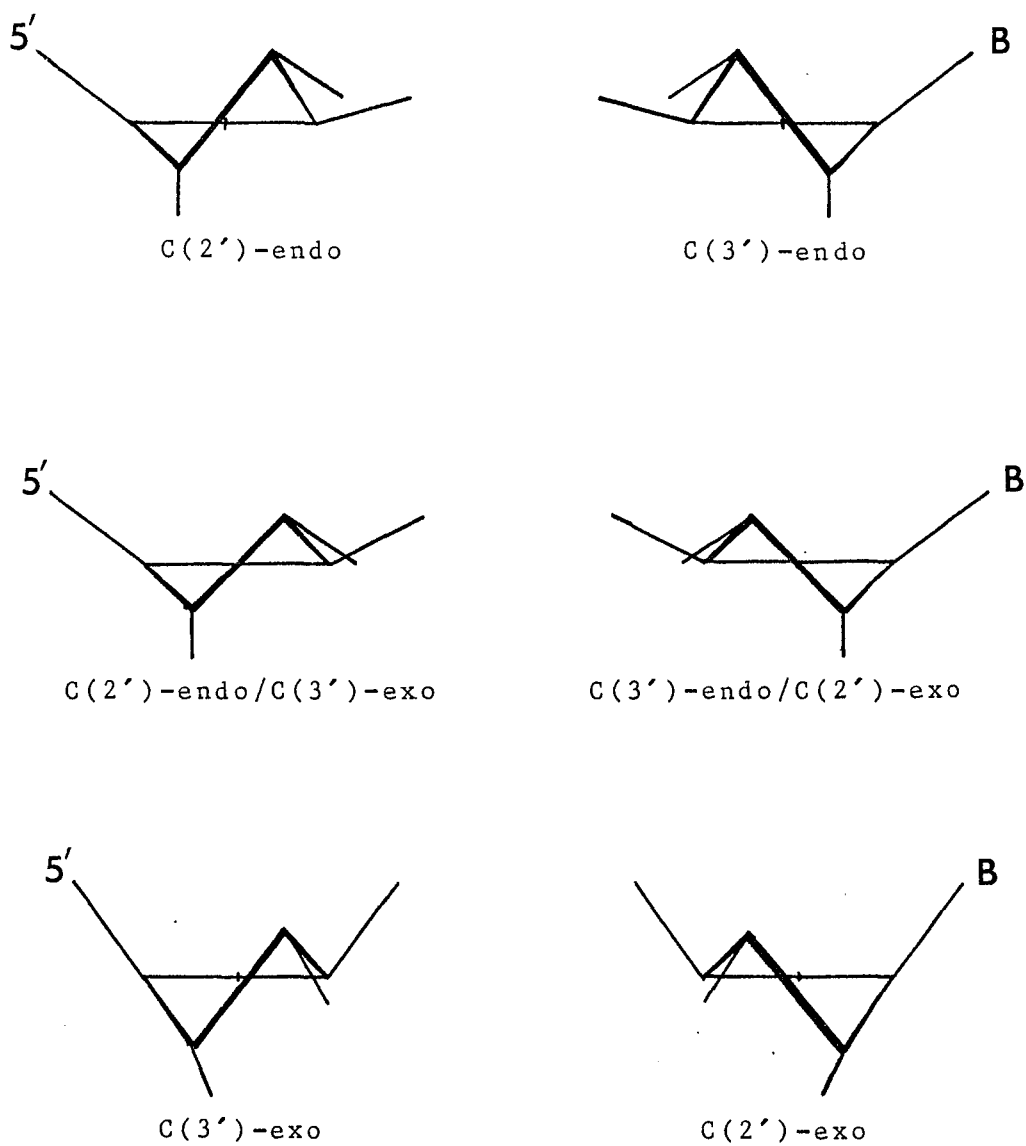

FIGURE 11. Representative Ribofuranose Ring Conformations.

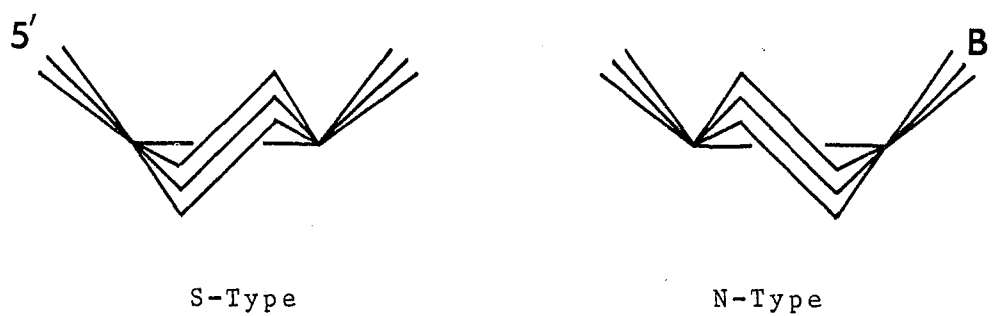

FIGURE 12. N S Type Conformers of the Ribofuranose Ring.

Current data indicate that furanose rings do not possess a unique rigid structure in solution, but exist as a dynamic equilibrium between at least two favored puckered conformations. If the interconversion rate between conformers is sufficiently rapid, then the observed couplings represent weighted averages of couplings in the individual conformers. The vicinal couplings observed for SAM correspond to A conformer in Table 8 better than those observed for most nucleosides and nucleotides. In general, couplings are analyzed in terms of a conformational equilibrium between various puckered forms.^{71,72,74}

A number of reliable methods for estimating the relative contribution of N- and S-type conformers (Figure 12) in a rapid equilibrium situation have been proposed. Davies and Danyluk⁶⁴ have shown that the equilibrium constant for the $N \rightleftharpoons S$ equilibrium can be calculated directly from the ratio of the observed ${}^3J_{1'2'}$ and ${}^3J_{3'4'}$ coupling constants without invoking particular magnitudes for $J(N)$ if the effect of electronegativity on J is negligible.

$$K_{eq} = S/N = {}^3J_{1'2'}/{}^3J_{3'4'} \quad (3)$$

Within the confines of this reasonable assumption, the data clearly indicate the marked predominance of an S-type conformation such as $C_{3'}$ -exo. Purine nucleosides and nucleotides in anti-type conformations prefer S-type conformers.⁶⁷ In SAM, the $C_{3'}$ -exo conformation tips the $H_{3'}$ proton away from the bulky sulfonium center at $C_{5'}$.

Conformation About the Exocyclic Bond. The relative populations of rotational isomers corresponding to the energy minima which occur upon rotation about the C_{4'}-C_{5'} bond can be estimated from the analysis of the appropriate ³J. The ³J associated with the fragment of interest are assumed equivalent to the weighted average of the ³J in the three rotational isomers. This is expressed algebraically by equations (4), (5) and (6), where p₁, p₂ and p₃ are the relative populations of each rotamer and ³J_{1'}, ³J_{2'}, etc. are the vicinal coupling constants associated with each rotamer.

$${}^3J_{4'5'} = p_1 {}^3J_{1'} + p_2 {}^3J_{2'} + p_3 {}^3J_{3'} \quad (4)$$

$${}^3J_{4'5''} = p_1 {}^3J_{1''} + p_2 {}^3J_{2''} + p_3 {}^3J_{3''} \quad (5)$$

$$1 = p_1 + p_2 + p_3 \quad (6)$$

Davies⁶⁷ has recommended the Karplus parameters A = 9.7, B = 1.8 and C = 0 Hz for the analysis of the exocyclic bond in nucleosides and nucleotides. In calculating the ³J appropriate to equations (4) and (5), the effects of substituent orientation and electronegativity were considered in the proposal of equations (7) and (8).⁷⁵

$${}^3J_{4'5'} = 1.3p_1 + 2.7p_2 + 11.7p_3 \quad (7)$$

$${}^3J_{4'5''} = 1.3p_1 + 11.5p_2 + 5.8p_3 \quad (8)$$

The H_{4'}, H_{5'} and H_{5''} protons constitute a three-spin system of the ABX spectral type with coupling constants ³J_{4'5'} = 9.5 Hz, ³J_{4'5''} = 2.4 Hz and ²J_{5'5''} = -12.8 Hz. An

estimate of the rotational isomer population about the C_{4'}-C_{5'} bond indicates that one of the gauche-anti conformations (2 or 3) is very highly favored, Figure 13. Rotamer 1 is populated to about 2% and either 2 or 3 to about 93%. We cannot tell from the coupling constant alone whether it is rotamer 2 or 3 that is so profoundly favored; however, CPK molecular models indicate that there is less steric interaction between the methyl group and the purine and ribose ring systems in rotamer 3. Our estimate for the conformational preference for rotamer 3 is considerably larger than that found in most rotational isomer distributions. If rotamer 3 is the preferred ground state orientation about the C_{4'}-C_{5'} bond then the S-methyl group can project to the less hindered side making it more accessible to nucleophiles. This may have mechanistic significance.¹⁴

Remin and Shugar⁷⁶ have concluded that assignment of the downfield H₅ signal to H_{5'} is correct by comparison to the chemical shifts of uridine, β-pseudouridine and their 3'-monophosphates. This conclusion was reached independently in the analysis of N(3)-methyl-2',3'-O-isopropylidene uridine⁷⁷ and N(6)-dimethyl-2'3'-O-isopropylidene adenosine.⁷⁸ It is presently believed that the aforementioned assignment is correct for all nucleosides and for both 2'- and 3'-nucleotides.⁷⁹ For S-adenosyl-L-methionine, this assignment supports the conclusion that rotamer 3 is the preferred ground state orientation about the C_{4'}-C_{5'} bond.

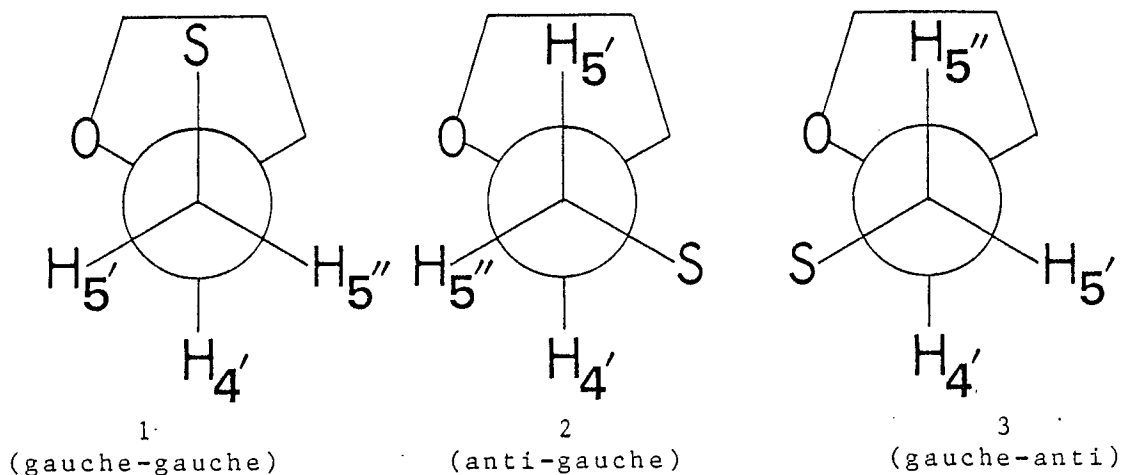

FIGURE 16. Rotational Isomers About the $C_{4'}-C_{5'}$ Bond

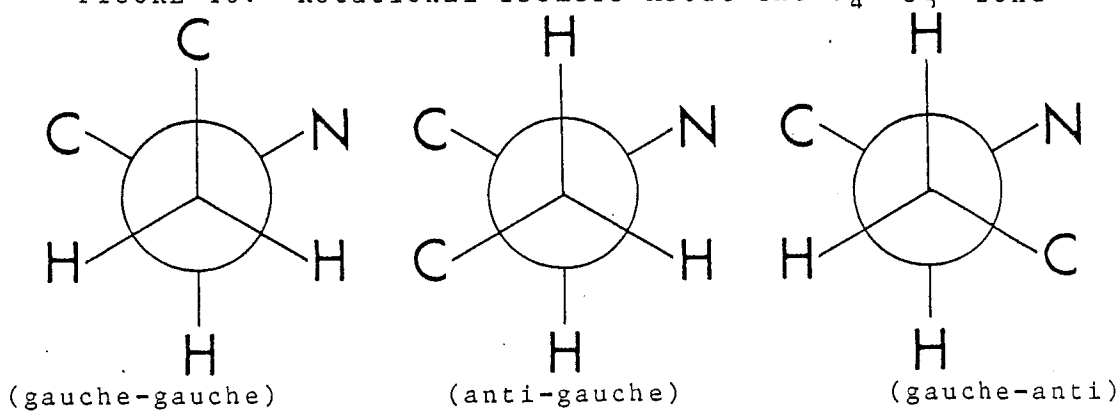

FIGURE 14. Rotational Isomers About the C - C Bond

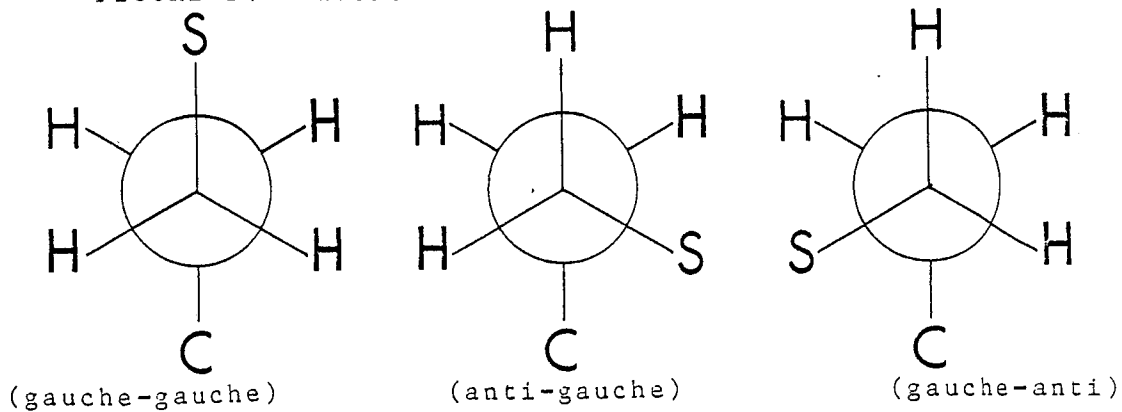

FIGURE 15. Rotational Isomers About the C - C Bond

Conformation of the Methionine Side Chain. The α -proton of the SAM methionine side chain appears as a triplet ($^3J_{\alpha\beta} = 6.6$ Hz), the γ -protons as a quartet and the β -protons as a 12-line multiplet (Figure 9). Homonuclear decoupling of the α -protons leaves the β -proton signal a triplet ($^3J_{\beta\gamma} = 7.4$ Hz) and the γ -resonance unchanged. Irradiation of the β -protons results in a singlet for the α -resonance and an AB quartet ($^2J_{\gamma\gamma} = -11.2$ Hz) for the γ -protons. Hence the β -protons are equivalent but the γ -protons, next to the asymmetric sulfonium group, are non-equivalent. Because the same coupling constant is obtained for both α - β interactions, the three rotational isomers about the C_α - C_β bond must be equally populated, Figure 14. The γ -protons differ in chemical shift but the β - γ interactions can also be described by a single coupling constant, again indicating that the rotational isomers are equally abundant, Figure 15.

Conformational Analysis of S-Adenosyl-L-homocysteine

The ribose ring protons comprise a six-spin system analogous to that of SAM. The observed coupling constants are: $^3J_{1'2'} = 5.21$ Hz, $^3J_{2'3'} = 5.0$ Hz, $^3J_{3'4'} = <0.5$ Hz, $^3J_{4'5'} = 4.85$ Hz, $^3J_{4'5''} = 6.44$ Hz and $^2J_{5'5''} = -14.13$ Hz. These values are also consistent with a $C_{3'}$ -exo ribose ring conformation. The rotational equilibrium about the $C_{4'}$ - $C_{5'}$ bond also exhibits a preference for an anti-gauche orientation although, unlike SAM, both such orientations are significantly populated (35% and 56%). The gauche-gauche orientation is populated to about 9%.

The α -proton of the SAH homocysteine side chain appears as a four-line multiplet (${}^3J_{\alpha\beta} = 4.68$ Hz and ${}^3J_{\alpha\beta} = 6.80$ Hz), the β -protons as a 24-line multiplet and the γ -protons as a triplet (Figure 6). Irradiation of the γ -protons decouples the β -protons resulting in an 8-line AB portion of an ABX spin system. The β -protons are non-equivalent (${}^2J_{\beta\beta} = -14.1$ Hz), whereas the γ -protons have equivalent chemical shifts (${}^3J_{\beta\gamma} = 7.45$ Hz). Abraham and Gatti⁸⁰ have derived equations (9) and (10) for the analysis of rotational isomer populations about the C_α - C_β bond of amino acid residues.

$${}^3J_{\alpha\beta} = 3.0p_1 + 12.7p_2 + 3.2p_3 \quad (9)$$

$${}^3J_{\alpha\beta} = 12.7p_1 + 3.9p_2 + 2.2p_3 \quad (10)$$

Equations (9) and (10) indicate a preference for the two anti-conformations about the C_α - C_β bond. The gauche-gauche conformer is populated to about 8% and the two gauche-anti conformers to about 33% and 59%. The β - γ proton interaction is fully described by a single coupling constant indicating that the rotational conformers about the C_β - C_γ bond are equally abundant.

Comparison Between SAM and SAH

The two cofactors have nearly equivalent ribose ring coupling constants and both clearly have C_3' -exo ring conformations. The slight differences in observed coupling constants are real and probably imply differences in the extent of ring deformation and dynamics, but no more can be said with certainty. SAM exhibits one highly favored gauche-

anti conformation about the C_{4'}-C_{5'} bond whereas SAH is distributed between both gauche-anti rotamers. In almost all other nucleosides and mononucleotides, the ribose ring has been shown to prefer a C_{2'}-endo conformation with the C_{4'}-C_{5'} bond in a gauche-gauche conformation.^{73,79} The different steric demands of the methionine and homocysteine side chains must account for the different conformations of SAM and SAH. The methionine side chain of SAM exhibits no preference for specific rotamers about the C_α-C_β and C_β-C_γ bonds whereas SAH reveals a preference for the gauche-anti rotamers about the C_α-C_β bond. In this regard we point out that rotation is unhindered about both side chains in SAM and S-methyl-L-methionine iodide whereas rotation about the C_α-C_β bonds of methionine and homocysteine encounters a significant torsional barrier. The rotation about the C_α-C_β bond of the methyl ester of S-methyl-L-methionine iodide is hindered and the γ-protons are non-equivalent: $^3J_{αβ} = 5.5$ Hz, $^3J_{αβ} = 7.9$ Hz, $^2J_{ββ} = -14.9$ Hz, $^3J_{βγ} = 5.9$ Hz and $^2J_{γγ} = -19.0$ Hz. This suggests that electrostatic interaction between the carboxyl group and the sulfonium center is not the dominant factor in determining the side chain mobility.

The Sulfonium Methyl Group

The functional portion of the SAM molecule is the sulfonium methyl group. The sharp singlet at 2.96 ppm can clearly be attributed to the methyl protons both by its chemical shift and the absence of coupling. However, in 1978 we have found that the sharp singlet attributed to the S-

methyl resonance is always accompanied by a second smaller upfield singlet regardless of commercial source, counter ion or solvent origin (Table 9). Our samples of (-)SAM were stable at room temperature and the relative intensities of these two peaks for a freshly prepared sample did not change over the course of several hours. Moreover purification of SAM by ion exchange chromatography on Amberlite IRC-150 did not change the relative intensities of these two peaks. Having accounted for all other observable spectral features, we are forced to attribute the upfield peak to the S-methyl protons of the "unnatural" sulfonium diastereomer (+)S-adenosyl-L-methionine and the downfield peak to the (-) diastereomer. This is confirmed by our observation that both peaks appear in the ^1H NMR spectrum of (\pm)SAM prepared by the reaction of SAH with methyl iodide in formic and acetic acids.²⁶ The starting material did not exhibit extraneous resonances and was stable in cold formic acid. Moreover, the spectrum of purified (\pm)SAM indicates that the (+) diastereomer is the major component (66%, see Figure 16).

TABLE 9. Chemical Shifts of the S-methyl Protons of Various S-Adenosyl-L-methionine Salts

	Iodide	Chloride	Bisulfate
(-)SAM	3.01	3.00	3.01
(+)SAM	2.96	2.96	2.97

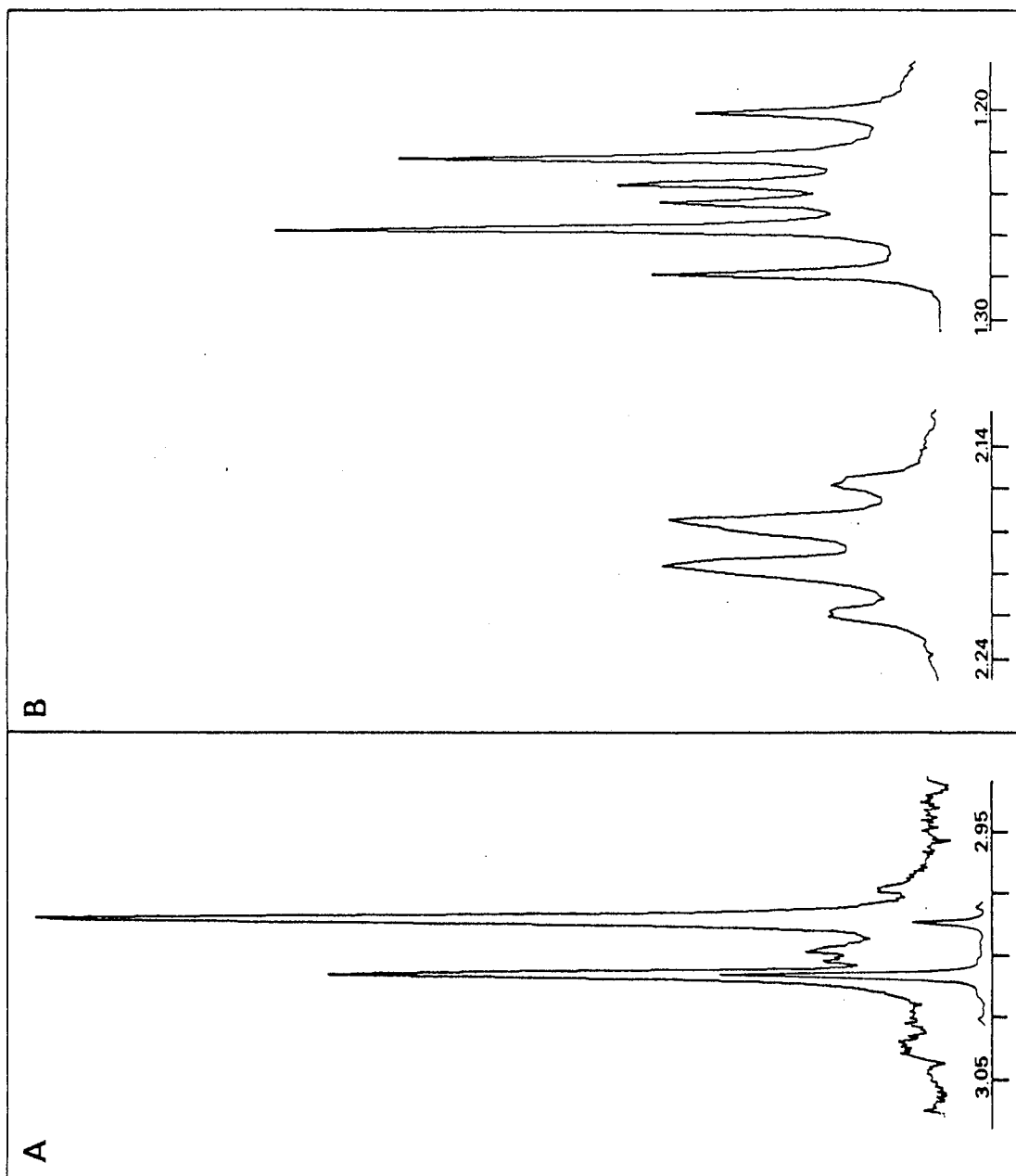

FIGURE 16. A: NMR Spectra of the Sulfonium Methyl Groups of (+)SAM (above) and (-)SAM (below). B: NMR Spectrum of the Sulfonium Ethyl Groups of S-Adenosyl-L-ethionine.

Recently, we have reexamined the ^{13}C spectrum of synthetic (\pm)S-adenosyl-L- $(^{13}\text{C}\text{H}_3\text{S})$ methionine at increased magnetic field. Two intense ^{13}C resonances (24.93 and 24.73 ppm) were observed in the proton decoupled spectrum with chemical shifts consistent with those found for methylsulfonium compounds.⁸¹ The two ^{13}C methyl resonances exhibit equivalent spin lattice relaxation times ($T_1 = 300$ ms) as well as equivalent C-H coupling constants ($J_{\text{CH}} = 150$ Hz.).

The 360 MHz ^1H spectrum of S-adenosyl-L-ethionine reveals the near equal abundance of two sulfonium ethyl groups (Figure 16). This compound was a commercial product, isolated from yeast grown in the presence of L-ethionine. The spectrum appears to be composed of two complete subspectra, one for each sulfonium diastereomer.

The upfield singlet peak in the spectrum of SAM cannot be attributed to methyl iodide or methanol because of its chemical shift and its presence after purification. It cannot be due to any known degradation product because these would exhibit additional peaks which are not observed. A diastereomer epimeric about the α -carbon of methionine can be ruled out because the SAH used to synthesize (\pm)SAM was clearly the L-epimer. Moreover, Schlenk⁸² has shown that SAM biosynthesized using racemic methionine is still exclusively S-adenosyl-L-methionine. There has been no report of spontaneous racemization at the sulfonium center of the (-) diastereomer, and the structurally related S-carboxymethyl-L-methionine sulfonium salt racemizes at the sulfonium center only after prolonged heating ($t_{1/2}$ @ $60^\circ\text{C} = 24$ hours).

Talalay et al.¹¹ did observe that degradation of S-adenosyl-L-(¹⁴CH₃S)methionine, prepared enzymatically, yielded about 10% of some radioactive impurity, chiral at sulfur but with the opposite sulfonium configuration.

We cannot say whether the (+) diastereomer in commercial samples is the result of some reaction during purification or whether both diastereomers are biosynthesized under the conditions used by suppliers. However, the widely held view that the naturally occurring cofactor is only the (-) diastereomer is based upon the assumption that synthetic (+)SAM is an equal mixture of both sulfonium diastereomers. Figure 16 shows this is not the case. De La Haba et al.,²⁶ Zappia, Zydek-Cwick and Schenk,³⁰ and Borchardt and Wu,³¹ found that synthetic (+)SAM exhibited about half the activity of SAM of biological origin and, by applying the reasonable assumption that (-)SAM was active and the (+) form inactive, concluded that biological SAM was entirely the (-) form. If samples of biological origin contain 10-20% of the (+) diastereomer, (Table 9, Figure 16), and if synthetic samples contain an excess of the (+) diastereomer, (Table 9, Figure 16) then the relative activity of the synthetic mixture would still be approximately half that of biological SAM.

Commercial preparations of SAM containing a small amount of (+)SAM have been widely employed in the analysis of transmethylations reactions.^{26,30,31} Borchardt and Wu³¹ have demonstrated that (+)SAM is a potent inhibitor of many transmethylations reactions. This suggests that the conclusions of prior investigations must be viewed with considerable caution.

Purification of HSMT

The purification of S-Adenosyl-L-methionine: L-Homocysteine S-Methyltransferase (HSMT) (EC. 2.1.1.10) from Saccharomyces cerevisiae is summarized in Table 10. The procedure offers a 12-fold increase in yield and a 3-fold increase in purification over the previous scheme,⁴⁰ Table 11. The various fractionations were repeated numerous times until optimal conditions were determined. Values appearing in Table 10 represent the average values obtained from seven repetitions of the purification sequence. The initial activity of the commercial yeast employed in this investigation was approximately half that reported for the previous purification scheme. This probably reflects the presence of methionine in the growth medium.⁴²

TABLE 10. Purification of S-Adenosyl-L-methionine:
L-Homocysteine S-Methyltransferase^a

Protein		Activity				
Volume mL	mg/mL	Total Protein	Total Activity	Yield %	Specific Activity	Purification Factor
1000 ^b	30.50	30500	2440	100	0.08	1
125 ^c	4.36	545	1439	60	2.64	33
130 ^d	0.29	38	475	20	12.42	155
40 ^e	0.028	1.1	357	15	118.40	1480

^aOne unit of enzyme activity was defined as the amount of enzyme catalyzing the production of 1 umole of SAH per hour. Total activity was measured in units. Specific activity was measured in units/mg protein. ^bToluene extraction. ^dAmmonium sulfate precipitation followed by Sephadex G25 gel exclusion chromatography. ^cDEAE Sephadex A50 ion-exchange chromatography. ^eL-Methionine AH-Sepharose 4B affinity chromatography.

TABLE 11. Previous Purification of S-Adenosyl-L-methionine:
L-Homocysteine S-Methyltransferase^{a, b}

	Total Protein	Total Activity	Yield %	Specific Activity	Purification Factor
c	30000	5000	100	0.17	1
d	360	1270	25	3.50	21
e	43	449	5	11.70	69
f	0.77	63	1.26	82.30	484

^aSee reference 40. ^bSee reference 83 for details of assay.
^cToluene extraction. ^dEthanol fractionation. ^eDEAE cellulose
batch treatment followed by DEAE Sephadex chromatography.
^fSephadex G75 gel exclusion chromatography.

Toluene Extraction. Cell-free extracts of Saccharomyces cerevisiae were obtained by toluene extraction as described by Shapiro *et al.*⁴⁰ The resulting solution was stored frozen at -15°C for up to 6 months prior to use.

Ammonium Sulfate Precipitation. Precipitation due to the addition of solid ammonium sulfate is illustrated in Figure 17. The enzyme activity was confined to fractions precipitated by the addition of 60 to 85% ammonium sulfate. This technique provided a rapid and convenient way to reduce the volume of working material in preparation for column chromatography. Ammonium sulfate precipitation compares favorably with the ethanol fractionation previously employed. Although the reduction in total protein is only one tenth that obtained by ethanol fractionation, 60% of the original activity is recovered as compared to 25% for the ethanol fractionation. Additionally, this procedure can be completed in only 3.5 hours as compared to the 20 hours required for the previous technique.

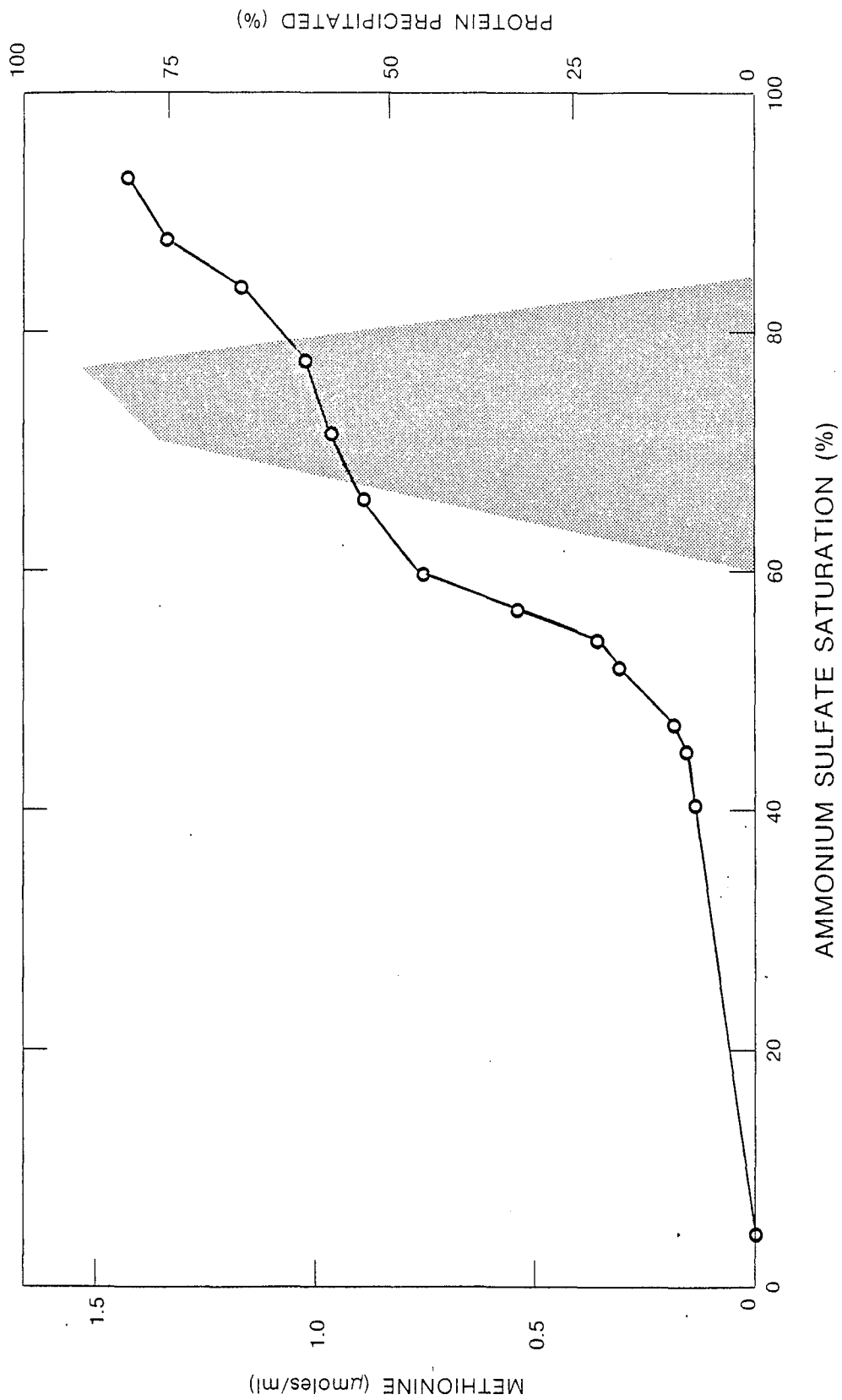

FIGURE 17. Protein Precipitation and Localizaion of Specific Activity as a Function of Ammonium Sulfate Saturation.

Sephadex G25 Gel Exclusion Chromatography. The ammonium sulfate protein precipitate was dissolved in 0.02 M Na⁺ phosphate buffer (pH 6.8) and desalted by chromatography on Sephadex G25 as illustrated in Figure 18. One third of the available material was purified during each chromatographic run. Chromatography resulted in a 2-fold increase in sample volume. The Enzyme activity was confined to the first peak eluted which corresponded to the void volume of the column. The chromatogram clearly indicates the removal of a low molecular weight protein fraction (<15,000) in addition to the removal of ammonium sulfate. Fractions obtained from three chromatographic runs were combined prior to the determination of enzymatic activity. The typical experiment resulted in a 33-fold purification with 60% recovery of the original activity.

DEAE Sephadex A50 Ion-Exchange Chromatography. The combined fractions from gel exclusion chromatography were purified by Ion-exchange chromatography on DEAE Sephadex A50 as illustrated in Figure 19. The inactive protein was eluted by the addition of 0.02 M Na⁺ phosphate buffer (pH 6.8) and emerged as a discrete peak immediately after the hold-up volume of the column. Protein exhibiting affinity for the cationic gel was eluted by the addition of 0.2 M Na⁺ phosphate buffer (pH 6.8). The enzyme activity was confined to the first peak eluted at high ionic strength. Gradient elution (0.02-0.2 M Na⁺ phosphate) was found to yield a similar peak profile but resulted in a broadening of the activity peak. Active fractions were combined and dialyzed

against 50 volumes of 0.02 M Na⁺ phosphate-0.05 M NaCl buffer (pH 7.0) prior to the determination of enzymatic activity. The typical experiment resulted in a 4.7-fold purification with 33% recovery of the original activity.

L-Methionine AH-Sepharose 4B Affinity Chromatography.

The dialyzed ion-exchange fraction was divided into three fractions of equal volume and each purified by chromatography on L-methionine AH-Sepharose 4B as illustrated in Figure 20. Protein exhibiting low affinity for the gel bound ligand was eluted by the addition of 0.02 M Na⁺ phosphate-0.05 M NaCl buffer (pH 7.0) before fractions were collected. Ligand bound protein was eluted by the addition of a 0.05-0.4 M NaCl gradient prepared in a constant volume mixing chamber. The enzyme activity was confined to the fourth peak eluted. NaCl gradients ranging from 0.05-0.45 to 0.05-1 M resulted in reduced resolution. Reduction in the slope of the NaCl gradient below 0.05-0.4 M resulted in increased resolution accompanied by a significant broadening of the peaks. Fractions exhibiting activity by the methionine assay after 8 hours of incubation were pooled and dialyzed against 50 volumes of 0.005 M Na⁺ phosphate buffer (pH 7.0) prior to the determination of enzymatic activity. The typical experiment resulted in a 10-fold purification with 75% recovery of the original activity.

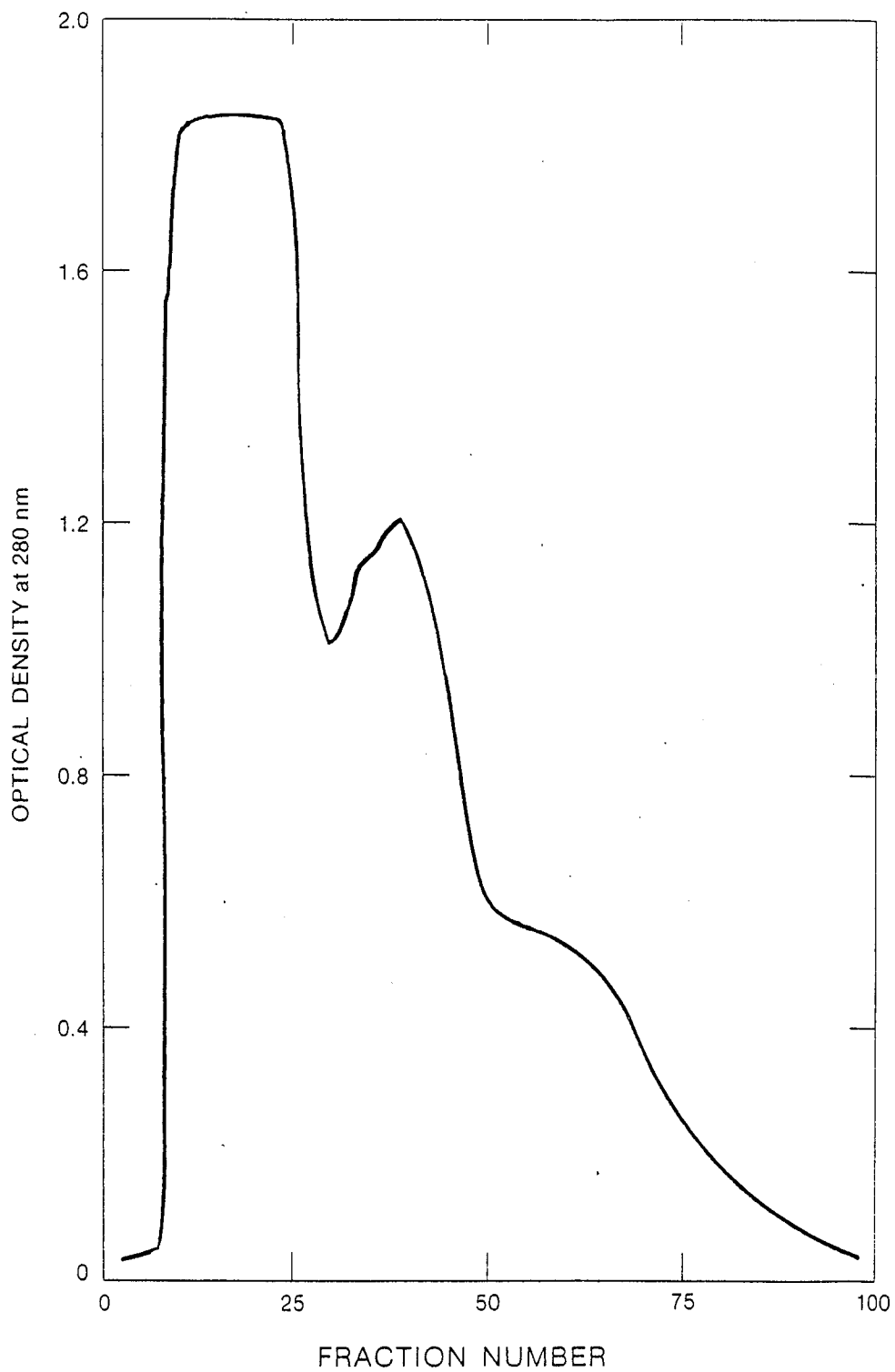

FIGURE 18. Gel Exclusion Chromatography of Ammonium Sulfate Precipitate on Sephadex G25.

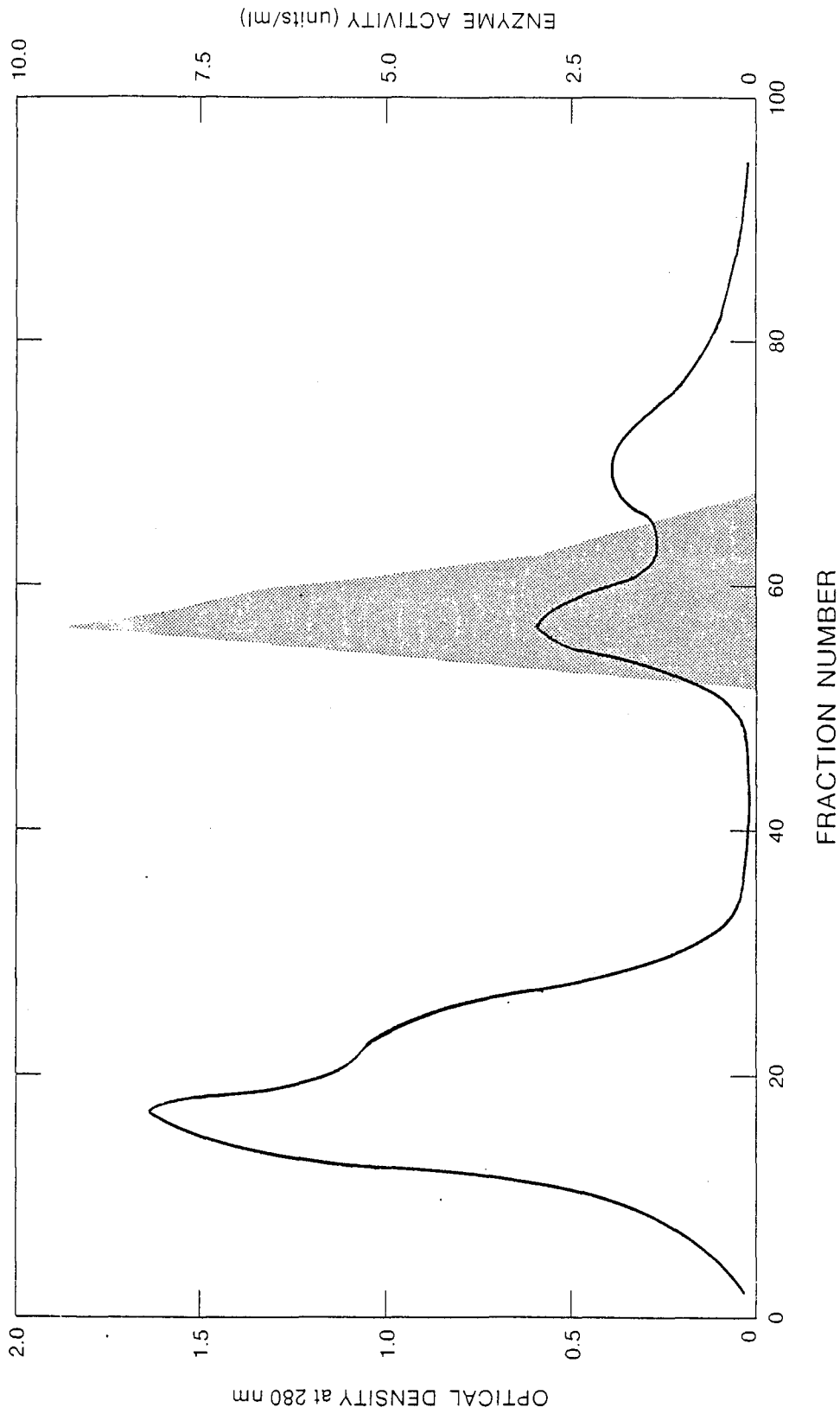

FIGURE 9. Ion-Exchange Chromatography of Sephadex G25 Fraction on DEAE Sephadex A50.

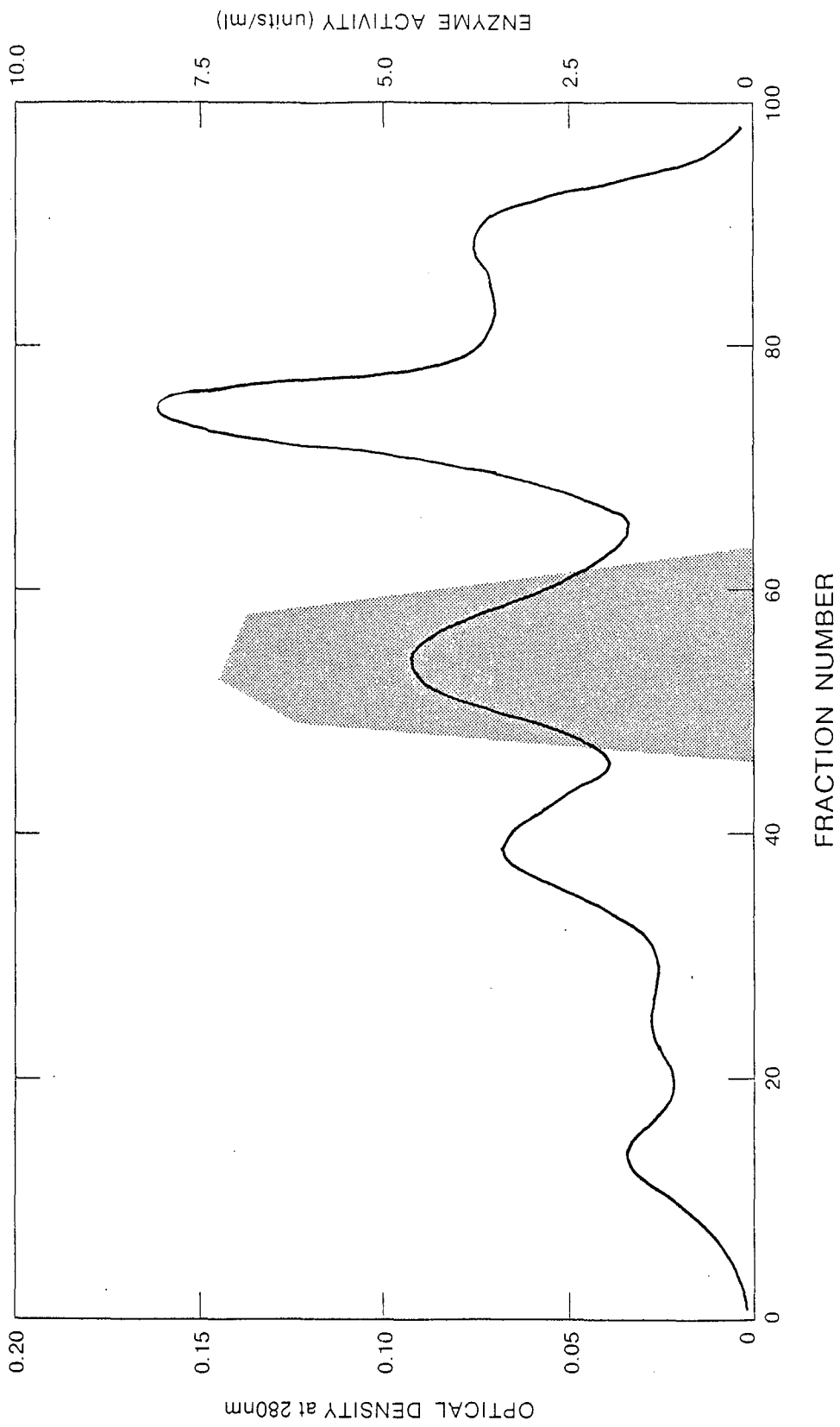

FIGURE 10. Affinity Chromatography of DEAE Sephadex A50 Fraction on L-Methionine AH-Sepharose 4B.

BIBLIOGRAPHY

1. Cantoni, G.L., J. Am. Chem. Soc., 74, 2942 (1952).
2. Coward, J.K. and Sweet, W.D., J. Org. Chem., 36, 2337 (1971).
3. Cantoni, G.L., J. Biol. Chem., 204, 403 (1953).
4. Nishimura, S., Taya, Y., Kuchino, Y. and Ohashi, Z., Biochem. Biophys. Res. Comm., 57, 702 (1974).
5. Tabor, H. and Tabor, C.W., Pharmacol. Rev., 16, 245 (1964).
6. Mudd, S.H. and Mann, J.D., J. Biol. Chem., 238, 2156 (1963).
7. Cantoni, G.L. and Scarano, E., J. Am. Chem. Soc., 76, 4744 (1954).
8. Swiatek, K.R., Simon, L.N. and Chao, K.-L., Biochemistry, 12, 4670 (1973).
9. Deguchi, T. and Barchas, J., J. Biol. Chem., 234, 603 (1971).
10. Mazza, F., Gavuzzo, E., Giglio, E. and Zappia, V., in "The Biochemistry of Adenosylmethionine," Columbia Univ. Press, New York, 145 (1977).
11. Cornforth, J.W., Reichard, S.A., Talalay, H.L., Carrell, H.L. and Glusker, J.P., J. Am. Chem. Soc., 178, 185 (1969).
12. Klee, W.A. and Mudd, S.H., Biochemistry, 6, 988 (1967).
13. Donohue, J. and Trueblood, K.N., J. Mol. Biol., 2, 363 (1960).
14. Hegazi, M.F., Borchardt, R.T. and Schowen, R.L., J. Am. Chem. Soc., 98, 3048 (1976).
15. Arigoni, D. Ciba. Found. Symp., 60, 243 (1978).
16. De La Haba, G. and Cantoni, G.L., J. Biol. Chem., 234, 603 (1958).
17. Borchardt, R.T. and Wu, S.W., J. Med. Chem., 17, 862 (1974).

18. Hildesheim, J., Hildesheim, R., Yon, J. and Lederer, E., Biochimie, 54, 989 (1972).
19. Borchardt, R.T., Huber, J.A. and Wu, S.W., J. Med. Chem., 19, 1094 (1976).
20. Borchardt, R.T., Huber, J.A. and Wu, S.Y., J. Med. Chem., 17, 868 (1974).
21. Borchardt, R.T. and Wu, S.Y., J. Med. Chem., 18, 300 (1975).
22. Borchardt, R.T. and Wu, S.Y., J. Med. Chem., 19, 198 (1976).
23. Borchardt, R.T., Wu, S.Y. and Wu, B.S., J. Med. Chem., 21, 1307 (1978).
24. Zappia, V., Zydek-Cwick, R. and Schlenk, F., J. Biol. Chem., 244, 4499 (1969).
25. Mudd, S.H. and Cantoni, G.L., Nature, 16, 1052 (1957).
26. De La Haba, G., Jamieson, G.A., Mudd, S.H. and Richards, H.H., J. Am. Chem. Soc., 81, 3975 (1959).
27. Parks, L.W., J. Biol. Chem., 232, 196 (1958).
28. Schlenk, F. and Dainko, J.L., Biochimica et Biophysica Acta, 385, 312 (1975).
29. Nakamura, K.D. and Schlenk, F., Arch. Biochem. Biophys., 177, 170 (1976).
30. Zappia, V., Zydek-Cwick, C.R. and Schlenk, F., Biochem. Biophys. Acta, 178, 185 (1969).
31. Borchardt, R.T. and Wu, Y.S., J. Med. Chem., 19, 1099 (1976).
32. Kjaer, A., Grue-Sørensen, Kelstrup, E. and Madsen, J.Ø. Pure & Appl. Chem., 52, 157 (1979).
33. Abrahamson, L. and Shapiro, S.K., Arch. Biochem. Biophys., 109, 376 (1965).
34. Shapiro, S.K., Biochem. Biophys. Acta, 18, 134 (1955).
35. Shapiro, S.K., Biochem. Biophys. Acta, 29, 405 (1958).
36. Durell, J., Anderson, D.G. and Cantoni, G.L., Biochem. Biophys. Acta, 26, 270 (1957).
37. Shapiro, S.K., Bacteriol Proc. (Soc. Am. Bacteriol.), 116 (1957).

38. Shapiro, S.K. and Yphantis, D.A., Arch. Biochem. Biophys., 82, 477 (1959).
39. Shapiro, S.K., Yphantis, D.A. and Almenas, A., J. Biol. Chem., 239, 1551 (1964).
40. Shapiro, S.K., Almenas, A. and Thomson, J.F., J. Biol. Chem., 249, 2512 (1965).
41. Mudd, S.H., Klee, W.A. and Ross, P.D., Biochemistry, 5, 1653 (1966).
42. Ferro, A.J. and Spence, K.D., J. Bacteriol., 116, 812 (1973).
43. Sharpless, T.K. and Wolfenden, R., Methods in Enzymology, 12A, 126 (1967).
44. Martin, M.L., Delpuech, J.J. and Martin, G.L., in "Practical NMR Spectroscopy," Heyden and Sons, London, 275 (1980).
45. Castellano, S. and Bothner-By, A.A., J. Chem. Phys., 12, 135 (1978).
46. Martin, M.L., Delpuech, J.J. and Martin, G.L., in "Practical NMR Spectroscopy," Heyden and Sons, London, 254 (1980).
47. Glasoe, R.K. and Long, F.A., J. Phys. Chem., 64, 188 (1960).
48. McCarthy, T.E. and Sullivan, M.X., J. Biol. Chem., 141, 871 (1941).
49. Csonka, F.A. and Denton, C.A., J. Biol. Chem., 163, 329 (1946).
50. Shapiro, S.K., J. Bacteriol., 72, 730 (1956).
51. Neuberger, C., Strauss, E. and Lipkin, L.R., Arch. Biochem., 4, 101 (1944).
52. Schlenk, F. and DePalma, R.E., J. Biol. Chem., 229, 1051 (1957).
53. Ennor, A.H. and Socken, L.A., Biochem. J., 42, 557 (1948).
54. Schlenk, F. and Zydek, C.R., Biochem Biophys. Res. Comm., 31, 427 (1968).
55. Bradford, M., Anal. Biochem., 72, 248 (1976).

56. Stolowitz, M.L. and Minch, M.J., J. Am. Chem. Soc., 103, 6015 (1981).
57. Stolowitz, M.L., "A Fourier Transform Nuclear Magnetic Resonance Study of the Molecular Conformation of S-Adenosyl-L-methionine", Thesis, Univ. of the Pacific, Stockton, California (1979).
58. Barfield, M. and Grant, D.M., Advances in Magnetic Resonance, 1, 149 (1965).
59. Karplus, M., J. Am. Chem. Soc., 85, 2870 (1963).
60. Karplus, M., J. Chem. Phys., 33, 1842 (1969).
61. Prestegard, J.H. and Chan, S.I., J. Am. Chem. Soc., 91, 2843 (1963).
62. Bystrov, Y.F., Russ. Chem. Rev., 41, 281 (1972).
63. Kowalewski, J.A., Prog. NMR Spectrosc. 10 (1976).
64. Davies, D.B. and Danyluk, S.S., Biochemistry, 13, 4417 (1974).
65. Altona, C. and Sundaralingam, M., J. Am. Chem. Soc., 94, 8205 (1962).
66. Altona, C. and Sundaralingam, M., J. Am. Chem. Soc., 95, 2333 (1973).
67. Davies, D.B., Prog. NMR Spectrosc., 12, 135 (1978).
68. Davies, D.B. and Danyluk, S.S., Biochemistry, 14, 543 (1975).
69. Smith, M. and Jardetsky, C.D., J. Mol. Spectrosc., 28, 70 (1968).
70. Hruska, F.E., Grey, A.A. and Smith, I.C.P., J. Am. Chem. Soc., 92, 4088 (1970).
71. Schleich, T., Blackburn, B.J., Lapper, R.D. and Smith, I.C.P., Biochemistry, 11, 137 (1972).
72. Sarma, R.H. and Mynott, R.J., J. Am. Chem. Soc., 95, 1641 (1973).
73. Sundaralingham, M. in "Conformations of Biological Molecules and Polymers," Academic Press, New York, 417 (1973).
74. Hruska, F.E. in "Conformations of Biological Molecules and Polymers," Academic Press, New York, 345 (1973).

75. Manor, P.C., Saenger, W., Davies, D.B., Jankowski, K. and Rabczenko, A., Biochem. Biophys. Acta, 340, 472 (1974).
76. Remin, M. and Shugar, D., Biochem. Biophys. Res. Commun., 48, 636 (1972).
77. Davies, D.B. and Rabczenko, A.R., J. Chem. Soc. Perkin Trans., 2, 1703 (1975).
78. Plochocka, D., Rabczenko, A.R. and Davies, D.B., Biochem. Biophys. Acta, 476, 1 (1977).
79. Sundaralingham, M., Biopolymers, 7, 821 (1969).
80. Abraham, R.J. and Gatti, G., J. Chem. Soc., B, 961 (1969).
81. Barbarella, G., Dembech, P., Garbesi, A. and Fava, A., Org. Magn. Reson., 8, 108 (1976).
82. Schlenk, F., Dev. Neurosci., 5, 3 (1978).
83. Shapiro, S.K. in "Methods in Enzymology," 17B, 400 (1971).