



12-5-1992

# Purification and ligand binding of a soluble class I MHC molecule consisting of the first three domains of H-2Kd fused to b2-microglobulin expressed in the baculovirus/insect cell system

Francois Godeau

*Institut Pasteur*

Immanuel F. Luescher

*Ludwig Institute for Cancer Research*

David M. Ojcius

*Institut Pasteur*, [dojcius@pacific.edu](mailto:dojcius@pacific.edu)

Cecile Saucier

Estelle Mottez

*See next page for additional authors*

Follow this and additional works at: <https://scholarlycommons.pacific.edu/dugoni-facarticles>

 Part of the [Biochemistry Commons](#), [Immunity Commons](#), [Immunology of Infectious Disease Commons](#), and the [Medical Immunology Commons](#)

## Recommended Citation

Godeau, F., Luescher, I. F., Ojcius, D. M., Saucier, C., Mottez, E., Cabanie, L., & Kourilsky, P. (1992). Purification and ligand binding of a soluble class I MHC molecule consisting of the first three domains of H-2Kd fused to b2-microglobulin expressed in the baculovirus/insect cell system. *Journal of Biological Chemistry*, 267(34), 24223–24229.

<https://scholarlycommons.pacific.edu/dugoni-facarticles/93>

This Article is brought to you for free and open access by the Arthur A. Dugoni School of Dentistry at Scholarly Commons. It has been accepted for inclusion in Dugoni School of Dentistry Faculty Articles by an authorized administrator of Scholarly Commons. For more information, please contact [mgibney@pacific.edu](mailto:mgibney@pacific.edu).

---

**Authors**

Francois Godeau, Immanuel F. Luescher, David M. Ojcius, Cecile Saucier, Estelle Mottez, Lucien Cabanie, and Philippe Kourilsky

## Purification and Ligand Binding of a Soluble Class I Major Histocompatibility Complex Molecule Consisting of the First Three Domains of H-2K<sup>d</sup> Fused to $\beta_2$ -Microglobulin Expressed in the Baculovirus-Insect Cell System\*

(Received for publication, May 8, 1992)

François Godeau‡, Immanuel F. Luescher§, David M. Ojcius, Cécile Saucier, Estelle Mottez, Lucien Cabanie¶, and Philippe Kourilsky

From the Unité de Biologie Moléculaire du Gène, Institut National de la Santé et de la Recherche Médicale U 277 and ¶Unité de Technologie Cellulaire, Institut Pasteur, 28, rue du Docteur Roux, 75724 Paris Cedex 15, France, and the §Ludwig Institute for Cancer Research, Chemin des Boveresses, Epalinges CH 1066, Switzerland

A recombinant baculovirus encoding a single-chain murine major histocompatibility complex class I molecule in which the first three domains of H-2K<sup>d</sup> are fused to  $\beta_2$ -microglobulin ( $\beta_2$ -m) via a 15-amino acid linker has been isolated and used to infect lepidopteran cells. A soluble, 391-amino acid single-chain H-2K<sup>d</sup> (SC-K<sup>d</sup>) molecule of 48 kDa was synthesized and glycosylated in insect cells and could be purified in the absence of detergents by affinity chromatography using the anti-H-2K<sup>d</sup> monoclonal antibody SF1.1.1.1. We tested the ability of SC-K<sup>d</sup> to bind antigenic peptides using a direct binding assay based on photoaffinity labeling. The photoreactive derivative was prepared from the H-2K<sup>d</sup>-restricted *Plasmodium berghei* circumsporozoite protein (*P.b.* CS) peptide 253-260 (YIPSAEKI), a probe that we had previously shown to be unable to bind to the H-2K<sup>d</sup> heavy chain in infected cells in the absence of co-expressed  $\beta_2$ -microglobulin. SC-K<sup>d</sup> expressed in insect cells did not require additional mouse  $\beta_2$ -m to bind the photoprobe, indicating that the covalently attached  $\beta_2$ -m could substitute for the free molecule. Similarly, binding of the *P.b.* CS photoaffinity probe to the purified SC-K<sup>d</sup> molecule was unaffected by the addition of exogenous  $\beta_2$ -m. This is in contrast to H-2K<sup>d</sup>Q<sub>10</sub>, a soluble H-2K<sup>d</sup> molecule in which  $\beta_2$ -m is noncovalently bound to the soluble heavy chain, whose ability to bind the photoaffinity probe is greatly enhanced in the presence of an excess of exogenous  $\beta_2$ -m. The binding of the probe to SC-K<sup>d</sup> was allele-specific, since labeling was selectively inhibited only by antigenic peptides known to be presented by the H-2K<sup>d</sup> molecule.

nously derived antigenic peptides to CD8-positive cytotoxic T lymphocytes (Townsend and Bodmer, 1989; Rothbard and Geftter, 1991). The general features of class I molecule biosynthesis have been known for some time both *in vitro* (Dobberstein *et al.*, 1979) and *in vivo* (Kranzel *et al.*, 1979). *N*-Linked core glycosylation occurs during biosynthesis of MHC class I heavy chains in the endoplasmic reticulum (see Kornfeld and Kornfeld (1985) for review), and after  $\beta_2$ -m association (Sege *et al.*, 1981), the heterodimer is transported along the secretory pathway to the cell surface (Owen *et al.*, 1980). The mechanism by which endogenous antigenic peptides associate with class I molecules is still incompletely understood, but current evidence suggests that it takes place in the endoplasmic reticulum (Nutchern *et al.*, 1989; Yewdell and Bennink, 1989; Kvist and Hammann, 1990).

The three-dimensional structure of HLA-A2 has revealed that the  $\alpha 1$  and  $\alpha 2$  domains of the heavy chain fold in a manner constituting an extended, groove-like peptide binding site (Bjorkman *et al.*, 1987a, 1987b). Class I molecules on cell surfaces contain short peptides (8-10 amino acids) with distinct allele-specific binding motifs (Falk *et al.*, 1991; Jardetzky *et al.*, 1991). The binding of antigenic peptides to MHC class I molecules is closely interrelated to the binding of  $\beta_2$ -m to the heavy chain. This is explained, on the one hand, by the intimate interactions of  $\beta_2$ -m not only with the  $\alpha 3$  domain but also with the  $\alpha 1$  and  $\alpha 2$  domains, which is likely to be important for the conformation of the peptide binding site (Saper *et al.*, 1991). On the other hand, stable assembly of the class I heterodimer depends on occupancy of the heavy chain peptide binding site (Townsend *et al.*, 1989). Indeed, this hypothesis is supported by recent work with class I assembly-defective mutant cell lines (Townsend *et al.*, 1989; Cerundolo *et al.*, 1990; Townsend *et al.*, 1990) and with purified human class I molecules (Silver *et al.*, 1991), which has shown that suitable antigenic peptides promote class I molecule assembly. Furthermore, there is evidence that peptide epitopes induce a conformational change of the heavy chain, resulting in increased affinity for  $\beta_2$ -m (Elliot *et al.*, 1991), and that free heavy chains present on the cell surface are functionally inactive (Rock *et al.*, 1991a, 1991b).

Clearly, further understanding of these interactions will depend on the availability of reconstituted systems using purified molecules. In this respect, the insect-baculovirus expression system has proved particularly useful in recent years for producing, in relatively large quantities, recombinant proteins that are authentically folded, proteolytically processed, post-translationally modified, and biologically active.

Class I major histocompatibility complex (MHC)<sup>1</sup> molecules are highly polymorphic 45-kDa integral membrane glycoproteins associated with the 12-kDa soluble  $\beta_2$ -microglobulin ( $\beta_2$ -m), and are involved in the presentation of endoge-

\* The costs of publication of this article were defrayed in part by the payment of page charges. This article must therefore be hereby marked "advertisement" in accordance with 18 U.S.C. Section 1734 solely to indicate this fact.

‡ To whom correspondence should be addressed.

<sup>1</sup> The abbreviations used are: MHC, major histocompatibility complex; AcNPV, *A. californica* nuclear polyhedrosis virus;  $\beta_2$ -m,  $\beta_2$ -microglobulin; mAb, monoclonal antibody; PAGE, polyacrylamide gel; SC-H-2K<sup>d</sup>, single-chain H-2K<sup>d</sup>; IASA, iodo-4-azido salicylic acid; HPLC, high performance liquid chromatography; PVDF, polyvinylidene difluoride; *P.b.* CS, *P. berghei* circumsporozoite protein.

In this system, the foreign gene is cloned downstream of a strong very late promoter and introduced via homologous recombination back into the genome of *Autographa californica* nuclear polyhedrosis virus (AcNPV) (Miller, 1988; Luckow and Summers, 1989; Maeda, 1989). We have previously used this approach to produce biologically active mouse  $\beta_2$ -m<sup>a</sup> (Dargemont *et al.*, 1989; Godeau *et al.*, 1991) and a H-2K<sup>d</sup> heavy chain which is able to associate with  $\beta_2$ -m in an antigenic peptide-dependent manner and form a functional heterodimer able to bind peptides (Godeau *et al.*, 1992). However, in doubly infected cells, the extent of association between the heavy and light chain is low and hence precludes isolation of larger amounts of assembled molecules. To circumvent this difficulty, we chose to express a fusion protein comprising the first three domains of H-2K<sup>d</sup> heavy chain fused to mouse  $\beta_2$ -microglobulin. We describe here some characteristics of this purified soluble protein and demonstrate that its interaction with antigenic peptides is identical to that observed with natural H-2K<sup>d</sup> molecules.

#### MATERIALS AND METHODS

**Cell Culture and Transfection**—Suspension or monolayer cultures of the Sf9 cell line from *Spodoptera frugiperda* were maintained at 27 °C in TC 100 medium supplemented with 0.33% Yeastolate (Difco) and containing 4% heat-inactivated fetal bovine serum, 50  $\mu$ g/ml penicillin, and 50  $\mu$ g/ml streptomycin. Cell densities were routinely kept between  $2.5 \times 10^5$  and  $1.5 \times 10^6$ /ml by passaging the cells in fresh medium. DNAs from recombinant plasmids (20  $\mu$ g) and viral DNA (10  $\mu$ g) were co-transfected by electroporation using a standard cuvette with a 0.4-cm gap containing 1 ml of Sf9 cell suspension ( $0.3$ – $1.0 \times 10^7$  cells/ml) in BNP (25 mM 2-[bis(2-hydroxyethyl)amino] ethanesulfonic acid, pH 6.95, 140 mM NaCl, 1.5 mM NaH<sub>2</sub>PO<sub>4</sub>, and 1 mM glucose) in the presence of 500  $\mu$ g/ml herring sperm DNA and exposed to the exponential discharge of a 1030  $\mu$ F capacitance charged under 220 V (Godeau, 1990; Godeau *et al.*, 1992). For large scale recombinant protein preparations, viral stock was prepared and used to infect at a multiplicity of infection >10. Sf9 cells were grown in aerated spinner flasks and fed, after infection, with serum-free TC 100 medium. Seventy-two hours postinfection, the suspension was collected and infected cells were removed by centrifugation.

**Isolation of AcNPV SC-H-2K<sup>d</sup> Recombinant Baculovirus**—All plasmids were constructed and purified according to standard recombinant DNA techniques (Sambrook *et al.*, 1989) except that transformation of *Escherichia coli* hosts was performed by electroporation (Dover *et al.*, 1988). Conditions for restriction endonuclease digestions were those suggested by the manufacturer. DNA fragments were isolated from agarose gels by electroelution. The transfer vector used in this study was the nonfusion pAcYM1 (Matsuura *et al.*, 1987), kindly provided by Dr. D. Bishop, which was cleaved by digestion with BamHI restriction endonuclease and filled in with *E. coli* DNA polymerase large fragment. The structure of SC-K<sup>d</sup> chimeric cDNA has already been described (Mottez *et al.*, 1991). Briefly, the entire coding sequence comprises the four H-2K<sup>d</sup> exons encoding H-2K<sup>d</sup> signal sequence,  $\alpha_1$ ,  $\alpha_2$ , and  $\alpha_3$  domains fused to the mouse  $\beta_2$ -m<sup>a</sup> coding sequence lacking its signal sequence via a 45-base pair linker with the sequence: 5'GGG GGG ATC GGA TCC GGA GGC GGT GGA TCC GGT GGC GGC GGT TCG3'. This DNA sequence, which encodes a 15-amino acid protein sequence predominantly composed of glycine and serine residues, was chosen for its expected flexibility and is represented in Fig. 1. To generate a recombinant baculovirus, SC-K<sup>d</sup> chimeric cDNA was excised from pSC-K<sup>d</sup>-15 (Mottez *et al.*, 1991) by digestion with HindIII restriction endonuclease, filled in with *E. coli* DNA polymerase large fragment, and subsequently blunt-end ligated into the filled in BamHI site of pAcYM1 transfer vector. Transformants were selected for proper orientation with respect to the polyhedrin gene transcriptional start site. Plasmid DNA was isolated and transfected together with viral DNA by electroporation, as already described (Chu *et al.*, 1987; Godeau, 1990). Five to seven days after transfection, the viral progeny containing a mixture of wild type and recombinant viruses was submitted to a purification procedure based on limiting dilution in 96-well microtiter plates followed by hybridization to a H-2K<sup>d</sup> probe. Five to seven days after infection, the virus-containing, adhering cell monolayer was directly dissolved in 200  $\mu$ l of 0.4 M NaOH and transferred to a nylon filter (Gene-

Screen Plus, Du Pont) via a dot-blot manifold (Reed and Mann, 1985). The filter was hybridized (Church and Gilbert, 1984) to a <sup>32</sup>P-labeled (Feinberg and Vogelstein, 1983) H-2K<sup>d</sup> probe, and the recombinant virus-containing medium from positive wells was further purified by a subsequent repeat of this dilution-hybridization procedure leading to the isolation of AcNPV-SC-K<sup>d</sup>. The viruses encoding murine  $\beta_2$ -m<sup>a</sup>, AcNPV- $\beta_2$ -m (Godeau *et al.*, 1991), and H-2K<sup>d</sup> heavy chain, AcNPV-K<sup>d</sup> (Godeau *et al.*, 1992), have already been described.

**Purification of SC-K<sup>d</sup>**—Immunoaffinity matrices were prepared by using anti-H-2K<sup>d</sup> monoclonal antibodies SF1.1.1.1 from ATCC and 34-1-2 (Ozato *et al.*, 1980). Ten mg of pure IgG<sub>2a</sub> mAb were covalently coupled to protein A-Sepharose (Pharmacia) via dimethylpimelidate following the procedure of Schneider *et al.* (1982). After saturating unreacted amino groups with ethanolamine and washing the column extensively, 1 liter of medium conditioned by AcNPV-SC-K<sup>d</sup>-infected Sf9 cells was passed over the column during a 6-h period, after which the column was washed with 20 column volumes of phosphate-buffered saline. Bound material was eluted with 50 mM diethylamine, pH 11.5, and the material was neutralized with 200 mM triethanolamine/HCl, pH 7.5, and concentrated. For affinity chromatography with concanavalin A, the cell-free conditioned medium was first ultracentrifuged ( $100,000 \times g$  for 1 h), concentrated to one-tenth of the original volume, and dialyzed against 10 mM Tris, pH 7.5, 100 mM NaCl. The dialysate was passed through an immobilized concanavalin A column (IBF, France), eluted with  $\alpha$ -methylmannoside, and analyzed by immunoblot using an anti- $\beta_2$ -m antiserum.

**Biochemical Characterization of Purified SC-K<sup>d</sup>**—N-terminal sequence analysis of purified soluble SC-K<sup>d</sup> from insect cells was performed by automated Edman degradation after electrophoresis on SDS-PAGE and transfer to PVDF, as described (Matsudaira 1987), on an Applied Biosystems 470 gas-phase peptide sequencer. Phenylthiohydantoin amino acids were detected with an on-line Applied Biosystems 120 A analyzer. For internal peptide sequence determination, the purified protein was reduced and alkylated, transferred on PVDF membranes as described above and digested in 100 mM Tris-HCl, pH 8.5, with 1  $\mu$ g of porcine trypsin (Sigma) in a 1:50 enzyme to substrate ratio for 4 h at 37 °C. The digest was separated by HPLC on a C18 Vydac column (250  $\times$  2.1 mm) using a 0–60% acetonitrile gradient in 0.1% trifluoroacetic acid. A well resolved peak was chosen for sequence determination.

**Antibodies and Immunoblots**—The class I H-2<sup>d</sup>-specific monoclonal antibodies used were 34-1-2 (IgG 2a) (anti H-2K<sup>d</sup> and H-2D<sup>d</sup>) (Ozato *et al.*, 1980) and SF1.1.1.1 (IgG 2a) from ATCC. All antibodies were purified from ascites fluid according to established procedures (Ey *et al.*, 1978; Harlow and Lane, 1988). The rabbit serum raised against a fusion protein comprising the second half of the  $\alpha_2$  and all of the  $\alpha_3$  domain of H-2K<sup>d</sup> will be described,<sup>2</sup> and the rabbit antiserum anti-mouse  $\beta_2$ -m was from Dr. N. Tanigaki (Natori *et al.*, 1976).

Immunoblots were performed by dissolving and boiling protein samples in SDS-PAGE sample buffer followed by electrophoresis on 12.5% polyacrylamide gels (Laemmli, 1970). Electrotransfer was performed using the semidry method (Kyhse-Andersen, 1984) with PVDF membranes (Immobilon Millipore) in 50 mM Tris-borate buffer, pH 8.3, after the gel had been equilibrated for 5 min in the same buffer containing 0.1% SDS. Membranes were blocked in TBS (50 mM Tris, pH 7.5, 200 mM NaCl, 0.05% Tween 20) containing 3% gelatin and incubated with a 1:500 dilution of the antiserum in TBS 1% gelatin, washed, and developed using alkaline phosphatase-labeled secondary antibody (Blake *et al.*, 1984).

**Peptide Synthesis**—Peptides were synthesized using an Applied Biosystems model 430A peptide synthesizer and the standard *t*-butoxycarbonyl strategy (Merrifield, 1986). The deprotected peptides were purified on a C-18 reverse phase HPLC column, dissolved in phosphate-buffered saline, and stored frozen.

**Photoaffinity Labeling with the [<sup>125</sup>I]IASA-YIPSEAK(Biotin)I Peptide Probe**—The photoprobe was prepared by reacting freshly iodinated [<sup>125</sup>I]IASA-ONSu with the orthogonal biotinylated octapeptide from mouse malaria *Plasmodium berghei* circumsporozoite protein YIPSAEKI(biotin)I and purified by C-18 reversed phase HPLC as previously described (Luescher *et al.*, 1991, 1992). Handling of photoreactive materials was performed under dimmed light. For labeling whole cells, infected Sf9 cells were harvested after 48 h, washed in phosphate-buffered saline, resuspended ( $2 \times 10^6$  cells/ml) in serum-free TC 100 medium in the presence of [<sup>125</sup>I]IASA-YIPSEAK(biotin)I ( $1 \times 10^7$  cpm) for 6 h at 27 °C, and UV-irradiated at 4 °C for 10 min (15 watt lamp with an emission maximum at 312 nm). After labeling,

<sup>2</sup> F. Godeau and H. Ploegh, manuscript in preparation.

the cells were washed twice in cold medium and once in phosphate-buffered saline, detergent solubilized in 0.7% Nonidet P-40, and immunoprecipitated using SF1.1.1.1. mAb. After 1 h the lysate was centrifuged ( $15,000 \times g$  for 3 min), and the supernatant was filtered through disposable membrane filters (Millipore Nihon Kogyo, Yonezawa, Japan). Immunoprecipitation was performed on nitrocellulose membrane filters in a dot-blot manifold as described (Luescher, 1987). For each immunoprecipitation, 30  $\mu\text{g}$  of pure SF1.1.1.1 mAb was used. The immunoprecipitates were subjected to SDS-PAGE (10% acrylamide) under reducing conditions and the dried gels were exposed to XAR 5 (Kodak) films.

Photoaffinity labeling of purified SC-K<sup>d</sup> protein was performed using a similar procedure. One  $\mu\text{g}$  of purified protein was incubated with [<sup>125</sup>I]IASA-YIPSEAK(biotin)I ( $1 \times 10^7$  cpm) in 10  $\mu\text{l}$  of phosphate-buffered saline. Aliquots were incubated in polypropylene tubes (500 ml Eppendorf, Hamburg, Germany) at 24 °C for 3 h. The tubes were UV-irradiated in the reflector of the described UV lamp for 3 min. The samples were diluted with 450  $\mu\text{l}$  of phosphate-buffered saline containing 0.5% Nonidet P-40 and the labeled protein was immunoprecipitated as described above. For competition experiments, 1  $\mu\text{g}$  of purified protein was incubated with the photoprobe in the absence or presence of graded amounts of competitor peptides in 3-fold dilution steps up to 1000-fold molar excess with respect to the photoprobe. The competitor was added 15 min before addition of the photoprobe.

The K<sup>d</sup>Q<sub>10</sub> plasmid construct leading to the synthesis of a soluble chimeric heavy chain between the first two domains of H-2K<sup>d</sup> and the third domain and the 3' sequences of the Q<sub>10</sub><sup>b</sup> gene and its introduction into mouse L cells has been described (Luescher *et al.*, 1992). Culture medium conditioned by clone NR37.15.2. was used to purify the K<sup>d</sup>Q<sub>10</sub> protein by immunoaffinity on an SF 1.1.1.1 column as described above.

## RESULTS

**Biochemical Characterization of SC-K<sup>d</sup> Expressed in Baculovirus-infected Insect Cells**—The SC-K<sup>d</sup> construct, which comprises the signal sequence and the  $\alpha 1$ ,  $\alpha 2$ , and  $\alpha 3$  domains of the H-2K<sup>d</sup> heavy chain cDNA fused to the coding sequence of murine  $\beta_2\text{-m}^d$  via a 15-amino acid flexible linker, is represented in Fig. 1. Assuming proper cleavage of its signal sequence, the mature chimeric polypeptide should be 391 amino acids long. Thus the molecular mass of the core polypeptide (without taking into account possible glycosylation) should be approximately 43 kDa. This chimeric construct has already been shown to lead to the synthesis of a soluble, glycosylated

fusion protein after transfection in COS-1 cells (Mottez *et al.*, 1991). To express this molecule in the higher amounts required for biochemical studies, we chose the recombinant baculovirus system. Thus, the use of the selection procedure described under "Materials and Methods" led to the isolation of a recombinant baculovirus containing the SC-K<sup>d</sup> coding sequence under the transcriptional control of the polyhedrin promoter (AcNPV-SC-K<sup>d</sup>). Preliminary experiments showed that a 48-kDa polypeptide (the expected apparent molecular mass for SC-K<sup>d</sup> if one assumes that the two N-glycosylation sites are used) was present in the supernatant of metabolically labeled insect cells infected with this virus. This band could be immunoprecipitated by an anti-mouse  $\beta_2\text{-m}$  antiserum as well as by the 34-1-2 mAb recognizing the native conformation of the H-2K<sup>d</sup> heavy chain (Godeau *et al.*, 1992) (results not shown). Taken together, these results indicate that the SC-K<sup>d</sup> polypeptide is exported as a soluble protein in insect cells. In this fusion protein, the first three domains of the H-2K<sup>d</sup> heavy chain associate with mouse  $\beta_2\text{-m}$  in a manner that mimics the native conformation of the heterodimer.

To purify this soluble class I fusion protein, immunoaffinity chromatography with an immobilized SF1.1.1.1. mAb column was carried out using crude cell-free conditioned medium from infected cells as starting material. Whereas no prominent Coomassie Blue stainable band could be detected in an SDS-PAGE analysis of the crude supernatant, the eluate from the affinity column showed a single major band of approximately 48 kDa (Fig. 2). This procedure routinely yielded approximately 500  $\mu\text{g}$  of SC-K<sup>d</sup> per liter of conditioned medium. Immunoblot analysis was carried out to further characterize the purified protein. In addition to reacting with the H-2K<sup>d</sup>-specific rabbit antiserum raised against a fusion protein containing half of the  $\alpha 2$  and the entire  $\alpha 3$  domain of H-2K<sup>d</sup> (Fig. 3, panel A, lane a), this polypeptide also reacted with the anti-mouse  $\beta_2\text{-m}$  antibody (Fig. 3, panel A, lane b), indicating that the 48-kDa polypeptide contained both MHC Class I heavy and light chain sequences. We then analyzed the glycosylation of this molecule. Conditioned medium from serum-free cultures was thus passed over a concanavalin A column, and the  $\alpha$ -methylmannoside eluate was analyzed by immunoblot using

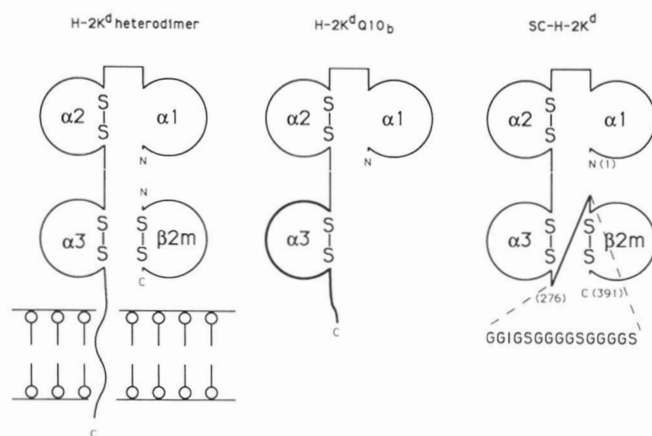

FIG. 1. Structure of the class I molecules used in this study.

Left, the membrane-associated class I H-2K<sup>d</sup> heterodimer with non-covalently attached  $\beta_2$ -microglobulin. Middle, recombinant chimeric soluble molecule H-2K<sup>d</sup>Q<sub>10</sub><sup>b</sup>. The portion in boldface indicates the sequence originating from the Q<sub>10</sub><sup>b</sup> class I gene. Although this molecule can associate with  $\beta_2\text{-m}$ , it has been represented without associated light chain. Right, recombinant chimeric soluble protein SC-H-2K<sup>d</sup>. The sequence of the 15-amino acid flexible linker, inserted between amino acid 276 of the mature H-2K<sup>d</sup> polypeptide and residue 1 of mature  $\beta_2\text{-m}$ , has been represented in the single letter code.

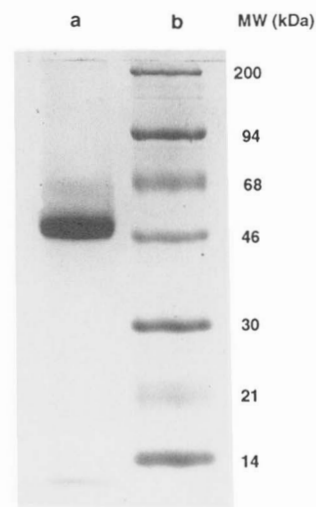

FIG. 2. One-step purification of SC-K<sup>d</sup> from the supernatant of Sf9 cells using an immunoaffinity column. One liter of serum-free culture medium conditioned for 72 h after infection by Sf9 cells infected with AcNPV-SC-K<sup>d</sup> was passed through an Sf1.1.1.1. mAb immunoaffinity column, eluted at pH 11.5, and freeze-dried. Five  $\mu\text{g}$  of protein were loaded on an SDS-PAGE which was stained with Coomassie Blue. Lane a, eluate from the immunoaffinity column; lane b, molecular weight standards.

the anti- $\beta_2$ -m antiserum. As shown in Fig. 3, *panel B*, a prominent 48-kDa and  $\beta_2$ -m immunoreactive band could be visualized in medium conditioned by AcNPV-SC-K<sup>d</sup>-infected cells which was absent from that of the wild type control, demonstrating that SC-K<sup>d</sup> contains mannose-rich carbohydrates.

To further confirm the identity of the purified protein, the 48-kDa polypeptide was sequenced following transfer onto PVDF membrane (thus further purifying the input protein). As shown in Table I, N-terminal sequencing yielded the sequence Gly-Pro-His, the expected N-terminal sequence of the mature H-2K<sup>d</sup> protein. This proves that the signal sequence of this polypeptide was cleaved in this expression system, as expected for a soluble protein recovered from a cell-free supernatant. Internal sequences were also obtained after tryptic digestion and separation of the digest by HPLC. One well separated peak was sequenced and shown to contain two distinct sequences in molar ratios differing by no more than a factor of 2. The first sequence, Tyr-Tyr-(Asp)-Gln, belongs to the H-2K<sup>d</sup> heavy chain and encompasses an N-glycosylation site. As expected for a glycosylated protein, the Asn residue is lacking in this sequence and replaced by a minute quantity of Asp. The second sequence, Ile-Pro-Lys, belongs to the mouse  $\beta_2$ -m coding sequence, further indicating that the  $\beta_2$ -m polypeptide was present in the SC-K<sup>d</sup> 48-kDa polypeptide. In view of the purity of the 48-kDa protein, no other peak was sequenced. Thus, among the three sequences obtained, all of them were derived from the expected sequences. Taken together, these results demonstrate that a soluble, 48-kDa, glycosylated SC-K<sup>d</sup> fusion protein with a correct N terminus is expressed efficiently in the baculovirus-insect cell system and can be isolated by a simple one-step procedure. In this polypeptide, the first three domains of H-

2K<sup>d</sup> are physically linked to mouse  $\beta_2$ -m and both sequences seem to fold to achieve a native conformation.

*The Binding of IASA-YIPSAEK(biotin)I to SC-K<sup>d</sup> Is Not Affected by Soluble  $\beta_2$ -m*—We then determined whether the single-chain class I molecule retained the ability of the parental molecule to bind antigenic peptide ligands. We thus used the recently described H-2K<sup>d</sup>-specific photoprobe derived from the octapeptide 253–260 of the mouse malaria *P. berghei* circumsporozoite protein IASA-YIPSAEK(biotin)I. In as much as photo-cross-linking is several orders of magnitude faster than the interaction of peptides with class I molecules (De Graff *et al.*, 1974; Luescher *et al.*, 1992), it directly reflects the binding of the peptide to class I molecules or any other cell component at the time of UV irradiation. We had previously shown that the binding of this photoprobe to the H-2K<sup>d</sup> produced in the baculovirus-insect cell system is dependent on the presence of  $\beta_2$ -m (Godeau *et al.*, 1992). We first examined the ability of the probe to label living insect cells infected with AcNPV-SC-K<sup>d</sup>. Thus, insect cells infected with various recombinant viruses were incubated with a 3 nM concentration of [<sup>125</sup>I]IASA-YIPSAEK(biotin)I and UV-irradiated, and following detergent solubilization, the various K<sup>d</sup> constructs were immunoprecipitated and analyzed by SDS-PAGE and autoradiography. As shown in Fig. 4 (*panel A*), a strong labeling of the 48 kDa band was observed in extracts of cells synthesizing the SC-K<sup>d</sup> polypeptide (*lane b*). Similarly, the H-2K<sup>d</sup> heavy chain synthesized in the presence of  $\beta_2$ -m, in Sf9 cells co-infected with AcNPV-K<sup>d</sup> and AcNPV- $\beta_2$ -m, strongly labeled as a 45 kDa band (*lane a*), but no labeling of the heavy chain could be detected in AcNPV-K<sup>d</sup> singly infected cells (*lane c*), nor was any band detectable in AcNPV- $\beta_2$ -m-infected cells (*lane d*) or wild type AcNPV-infected control cells (*lane e*). These results demonstrate that the SC-K<sup>d</sup> produced in insect cells is functional in terms of binding the H-2K<sup>d</sup>-restricted photoprobe and that the  $\beta_2$ -m molecule coupled to the heavy chain via the flexible 15-amino acid linker can replace free mouse  $\beta_2$ -m, which is required for significant binding of the photoprobe (Godeau *et al.*, 1992).

We then wished to examine the binding properties of the SC-K<sup>d</sup> protein by incubation of the purified protein with the photoprobe. As a control, we used the soluble class I molecule H-2K<sup>d</sup>Q<sub>10</sub>, purified in the same manner, in which the heavy and light chains are produced as individual polypeptides and are therefore noncovalently associated. As shown in Fig. 4, *panel B*, this molecule was able to bind the photoprobe (*lane c*), but maximal labeling intensity required the addition of an excess of exogenous human  $\beta_2$ -m (*lane d*). In contrast, purified SC-K<sup>d</sup> bound the photoprobe equally well in the absence or presence of an excess of human  $\beta_2$ -m. Taken together, these results indicate that the SC-K<sup>d</sup> fusion protein can bind peptides in a manner similar to that of the parental class I heterodimer.

*Inhibition of Photoreactive Peptide Binding to SC-K<sup>d</sup> by Unlabeled H-2K<sup>d</sup>-restricted Peptides*—We next examined the specificity of the observed labeling of the SC-K<sup>d</sup> molecule, by competition in the presence of various concentrations of unlabeled peptides, some of which were *bona fide* K<sup>d</sup>-restricted peptides while others were peptide epitopes restricted by

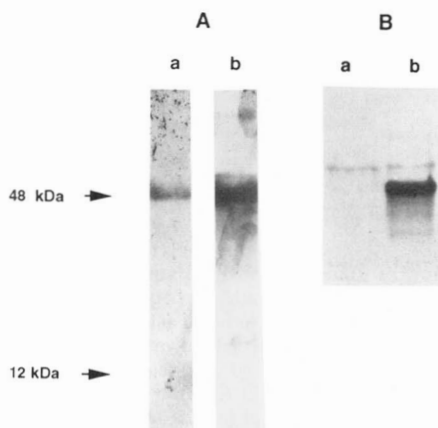

FIG. 3. Immunoblot analysis of the purified SC-K<sup>d</sup>. A, immunopurified SC-K<sup>d</sup> was loaded on SDS-PAGE and analyzed by immunoblot using either the anti-H-2K<sup>d</sup>  $\alpha_2$  and  $\alpha_3$  domain antiserum (*lane a*) or the anti-mouse  $\beta_2$ -m antiserum (*lane b*). B, serum-free conditioned medium from SC-K<sup>d</sup>-infected Sf9 cells was semipurified by concanavalin A affinity chromatography and analyzed by immunoblot using the anti-mouse  $\beta_2$ -m antiserum. Conditioned medium from Sf9 cells infected with wild type AcNPV (*lane a*); or with AcNPV-SC-K<sup>d</sup> (*lane b*). All blots were developed with an alkaline phosphatase second antibody.

TABLE I

Purified SC-K<sup>d</sup> N terminus and internal tryptic peptides

	H-2K <sup>d</sup> N terminus	H-2K <sup>d</sup> internal peptide	$\beta_2$ -m internal peptide
Observed sequence	NH <sub>2</sub> -Gly-Pro-His	NH <sub>2</sub> -Tyr-Tyr-(Asp)-Gln-	NH <sub>2</sub> -Ile-Pro-Lys-COOH
Expected sequence	NH <sub>2</sub> -Gly-Pro-His	NH <sub>2</sub> -Tyr-Tyr-Asn-Gln-Ser	NH <sub>2</sub> -Ile-Pro-Lys-COOH



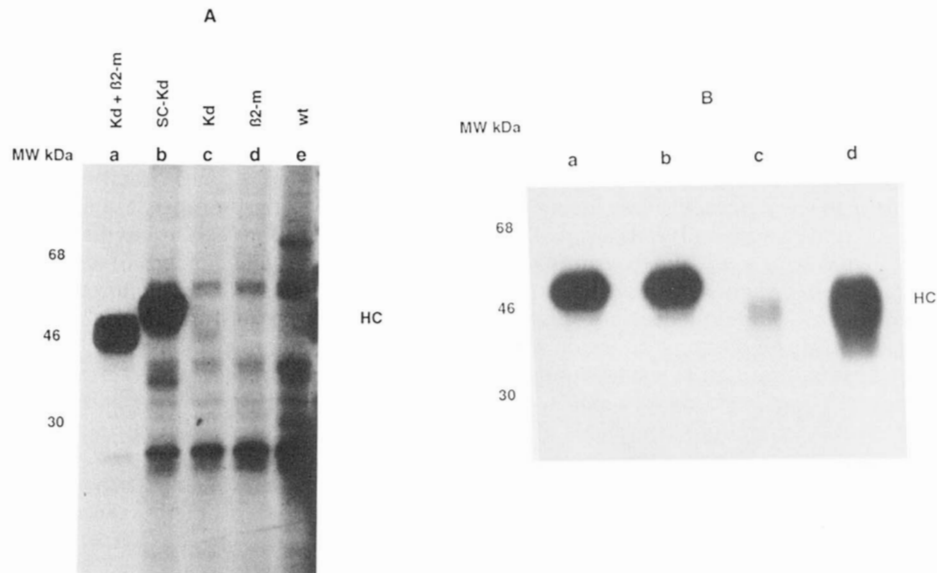
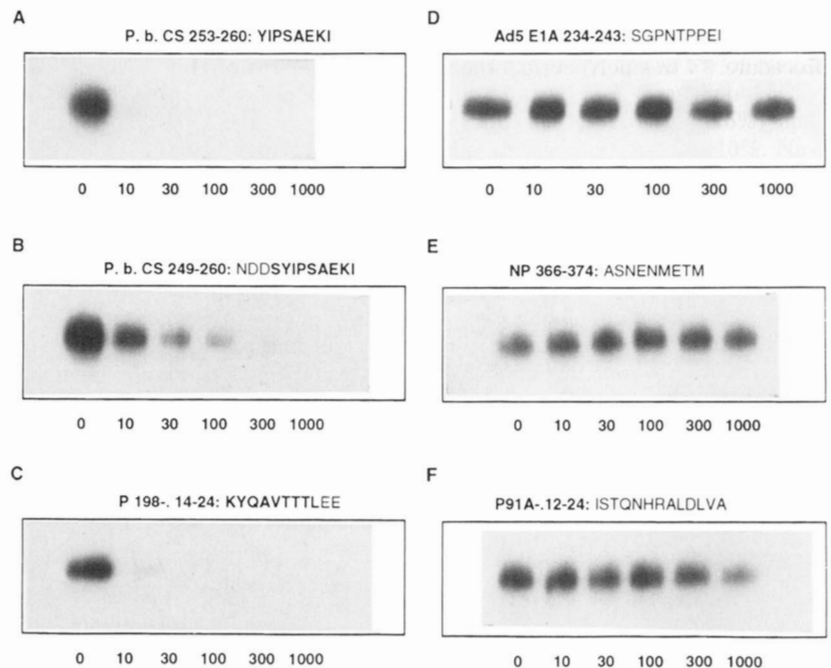

FIG. 4.  $\beta_2$ -m is not required for binding of the photoreactive peptide to SC-K<sup>d</sup>. A, Sf9 cells were infected with wild type AcNPV (*wt*) (lane *e*), AcNPV- $\beta_2$ -m (lane *d*), AcNPV-K<sup>d</sup> alone (lane *c*), AcNPV-SC-K<sup>d</sup> (lane *b*), or simultaneously with AcNPV-K<sup>d</sup> and AcNPV- $\beta_2$ -m (lane *a*). Two days after infection, cells were harvested, washed, and incubated in the presence of a 3 nM concentration of [<sup>125</sup>I]IASA-YIPSEAK(biotin)I. After UV irradiation, the cells were washed twice in cold medium and once in phosphate-buffered saline and directly dissolved in SDS-PAGE sample buffer prior to electrophoresis and autoradiography. B, 1  $\mu$ g of purified soluble H-2K<sup>d</sup> molecule was incubated with a 3 nM concentration of [<sup>125</sup>I]IASA-YIPSEAK(biotin)I, immunoprecipitated, and analyzed by SDS-PAGE and autoradiography. Immunopurified SC-K<sup>d</sup> (lanes *a* and *b*) or K<sub>d</sub>Q<sub>10</sub> (lanes *c* and *d*) were incubated either in the absence (lanes *a* and *c*) or presence (lane *b* and *d*) of a 3  $\mu$ g/ml concentration of human  $\beta_2$ -m. HC (heavy chain) indicates the relative mobility of the baculovirus-encoded unmodified H-2K<sup>d</sup> polypeptide.

**FIG. 5. Inhibition of photoreactive peptide binding to SC-K<sup>d</sup> by unlabeled H-2K<sup>d</sup>-restricted peptides.**

One  $\mu$ g of purified SC-K<sup>d</sup> was incubated with a 3 nM concentration of [<sup>125</sup>I]IASA-YIPSEAK(biotin)I in the presence of unlabeled peptides in the indicated molar excess, UV-irradiated, immunoprecipitated, and dissolved in SDS-PAGE sample buffer prior to electrophoresis and autoradiography. The following unlabeled peptide competitors were used: A, *P. berghei* circumsporozoite protein 253–260; B, *P. berghei* circumsporozoite protein 249–260 (Romero *et al.*, 1989); C, P198-14–24 (Sibille *et al.*, 1990); D, adenovirus 5 E1A gene product 234–243 (Kast *et al.*, 1989); E, influenza virus nucleoprotein 366–374 (Townsend *et al.*, 1986); and F, P91A-12–24 (Lurquin *et al.*, 1989). H-2K<sup>d</sup>-restricted peptides were used in panels A, B, and C, while H-2D<sup>b</sup>-restricted peptides were used in panels D and E and an H-2L<sup>d</sup>-restricted peptide in panel F. Sequence alignments with the minimal H-2K<sup>d</sup> consensus motif described by Falk *et al.* (1991) are shown in *boldface*.



either D<sup>b</sup> or L<sup>d</sup>. Photoaffinity labeling of the SC-K<sup>d</sup> molecule by radiolabeled IASA-YIPSAEK(biotin)I was completely inhibited using a 10-fold molar excess of the parental octamer *P. b.* CS (YIPSAEKI) (Fig. 5, panel A). Similarly, a dose-dependent inhibition was observed when the 12-mer *P. b.* CS 249–260 was used as a competitor, but the molar excess needed for complete inhibition was higher, as expected for a peptide that is suboptimal with respect to the minimal consensus motif for K<sup>d</sup>-restricted epitopes (Falk *et al.*, 1991; Romero *et al.*, 1991) (Fig. 5, panel B). The K<sup>d</sup>-restricted P 198- peptide

(Sibille *et al.*, 1990) was also a good competitor, although not as potent as *P. b.* CS (YIPSAEKI) (Fig. 5, panel C). In contrast, the H-2D<sup>b</sup>-restricted peptides Ad5 E1A 234–243 (Kast *et al.*, 1989; Luescher *et al.*, 1992) and NP 366–374 (Townsend *et al.*, 1986) had no inhibitory activity (Fig. 5, panels D and E). Finally, P91A-12–24, a L<sup>d</sup>-restricted peptide (Lurquin *et al.*, 1989), did not show any inhibitory activity. Thus, the specificity of *P. b.* CS (YIPSAEKI) photoprobe binding to the single-chain K<sup>d</sup> molecule correlated with the expected restriction pattern of the K<sup>d</sup> molecule, indicating

that the observed labeling represents authentic binding to a functional peptide binding site.

#### DISCUSSION

In the insect cell-baculovirus system, recombinant proteins often retain their biological activity (Miller, 1988; Luckow and Summers, 1989; Maeda 1989) and are produced in considerable amounts, thus permitting their purification and detailed analysis. Indeed, our previous work using this system has provided evidence for a significant production of biologically active mouse  $\beta_2$ -m<sup>a</sup> (Godeau *et al.*, 1991) and of a functional H-2K<sup>d</sup> heavy chain which was able to associate with  $\beta_2$ -m<sup>a</sup> in a peptide-dependent manner, so as to give rise to a functional heterodimer (Godeau *et al.*, 1992). Since our ultimate goal is to study a reconstituted system with purified molecules, the lack of complete heterodimerization observed in doubly infected cells prompted us to seek a more efficient system to produce a soluble molecule. The only studies reporting the successful production of soluble class I molecules have used a truncated heavy chain associated with the substitution of the transmembrane domain of the Q<sub>10</sub><sup>b</sup> molecule, leading to the production of a soluble class I molecule upon association with  $\beta_2$ -m (Margulies *et al.*, 1986; Schneck *et al.*, 1989). We have used another approach consisting of the creation of a fusion molecule of a truncated heavy chain linked to the light chain via a flexible 15-amino acid linker (Mottez *et al.*, 1991). Although the transiently transfected COS-1 cells do not constitute an expression system suitable for preparative purposes, we have previously shown that the single-chain H-2K<sup>d</sup> molecule produced in COS-1 cells bears some resemblance to the natural class I molecule (Mottez *et al.*, 1991), based on the presence of a conformational epitope recognized by the 34-1-2 mAb, which we have shown to be conformation-specific (Godeau *et al.*, 1992). However, the peptide binding assay (Bouillot *et al.*, 1989) used to initially assess the functionality of the fusion protein was subsequently reported to be of degenerate allele specificity (Chen *et al.*, 1990; Frelinger *et al.*, 1990).

We have expressed the truncated mouse class I major histocompatibility glycoprotein H-2K<sup>d</sup> in baculovirus-infected insect cells as a soluble, secreted fusion protein with mouse  $\beta_2$ -m<sup>a</sup>. Here we provide direct evidence that SC-K<sup>d</sup>, produced in the baculovirus expression system, is able to bind H-2K<sup>d</sup>-restricted peptide epitopes, since photoaffinity labeling of the purified soluble SC-K<sup>d</sup> by a H-2K<sup>d</sup>-restricted peptide derivative was specifically inhibited in the presence of antigenic peptides known to be presented by the H-2K<sup>d</sup> molecule. The competitor activity exhibited by a given peptide in the direct binding assay correlated with the activity determined in functional competition experiments (Luescher *et al.*, 1992) and with the relatedness of its respective sequence to the allele-specific consensus motifs described by Falk *et al.* (1991). Other peptides presented in the context of other class I molecules competed weakly if at all with the photoprobe. Thus, the binding properties of this fusion protein seem qualitatively indistinguishable from those of the cell-associated H-2K<sup>d</sup> molecule. Because we have shown that  $\beta_2$ -m is absolutely required for the binding of this ligand to the H-2K<sup>d</sup> heavy chain under the present experimental conditions (Godeau *et al.*, 1992), we can infer that the  $\beta_2$ -m linked covalently to the heavy chain plays a role identical to that of native  $\beta_2$ -m in stabilizing the native conformation of the heavy chain. Furthermore, in contrast to the soluble version of H-2K<sup>d</sup> (K<sup>d</sup>Q<sub>10</sub>), in which  $\beta_2$ -m is not covalently linked to the heavy chain, maximal peptide binding to the single-chain molecule can be achieved without addition of  $\beta_2$ -m, suggesting that the covalently linked murine

$\beta_2$ -m is effective at providing the heavy chain conformation necessary for peptide binding (Elliot *et al.*, 1991).

Other heterodimeric molecules of immunological interest have been produced as fusion proteins between the two chains of the original heterodimer and expressed in *E. coli* mostly as insoluble molecules. After denaturation and renaturation, however, it has been possible to recover a single-chain antibody Fv fragment retaining some of the affinity of the original immunoglobulin for its antigen (Huston *et al.*, 1988). Similarly, a variable fragment of a T-cell receptor, rendered soluble by site-directed mutagenesis, showed some antigen-combining properties after renaturation (Novotny *et al.*, 1991). Thus, this molecular design can lead to the synthesis of functional heterodimers and could possibly be used for other heterodimeric molecules.

As demonstrated in the present study, the baculovirus-insect cell system yields directly soluble molecules which are functional. Interestingly, the human class II MHC protein HLA-DR1 has recently been expressed in the baculovirus-insect cell system as a soluble heterodimer produced in an "empty" conformation able to bind peptide antigens (Stern and Wiley, 1992). It would be of interest to determine whether the soluble class I molecule herein described is also empty. Peptide binding and kinetic studies are presently in progress to settle this issue.

In conclusion, expression of the mouse class I histocompatibility antigen H-2K<sup>d</sup> as a fusion protein in insect cells is a convenient source of soluble mouse MHC class I heterodimer, which behaves as the native protein and should be particularly useful for peptide binding studies aimed at a biochemical and biophysical characterization of peptide-class I molecule complex formation.

*Acknowledgments*—We thank Dr. Tanigaki for the generous gift of antibodies, Dr. Bishop for the generous supply of vector, and Dr. G. Devauchelle for viruses and cell lines. We thank J. d'Alayer for protein sequence determinations. We are also greatly indebted to Drs. G.P. Corradin, P. Romero, and J. Maryanski for the generous supply of peptides.

#### REFERENCES

- Bjorkman, P. J., Saper, M. A., Samraoui, B., Bennett, W. S., Strominger, J. L., and Wiley, D. C. (1987a) *Nature* **329**, 506–512  
 Bjorkman, P. J., Saper, M. A., Samraoui, B., Bennett, W. S., Strominger, J. L., and Wiley, D. C. (1987b) *Nature* **329**, 512–518  
 Blake, M. S., Johnston, K. H., Russel-Jones, G. J., and Gotschlich, E. C. (1984) *Anal. Biochem.* **36**, 175–179  
 Bouillot, M., Choppin, J., Cornille, F., Martinon, F., Papo, T., Gomard, E., Fournie-Zalaski, M.-C., and Lévy, J.-P. (1989) *Nature* **339**, 473–475  
 Cerundolo, V., Alexander, J., Anderson, K., Lamb, C., Cresswell, P., McMichael, A., Gotch, F., and Townsend, A. (1990) *Nature* **345**, 449–452  
 Chen, B. P., Rothbard, J., and Parham, P. (1990) *J. Exp. Med.* **172**, 931–937  
 Chu, G., Hayakawa, H., and Berg, P. (1987) *Nucleic Acids Res.* **15**, 1311–1327  
 Church, G. M., and Gilbert, W. (1984) *Proc. Natl. Acad. Sci. U. S. A.* **81**, 1991–1995  
 Dargemont, C., Dunon, D., Deugnier, M. A., Denoyelle, M., Girault, J. M., Lederer, F., Le, K. H. D., Godeau, F., Thierry, J. P., and Imhof, B. A. (1989) *Science* **246**, 803–805  
 De Graff, B. A., Gillepsie, D. V., and Sundberg, R. J. (1974) *J. Am. Chem. Soc.* **96**, 7491–7498  
 Dobberstein, B. H. G., Warren, G., and Robinson, P. J. (1979) *Cell* **17**, 759–769  
 Dover, W. J., Miller, J. F., and Ragsdale, C. W. (1988) *Nucleic Acids Res.* **16**, 6127–6145  
 Elliot, T., Cerundolo, V., Elvin, J., and Townsend, A. (1991) *Nature* **351**, 402–406  
 Ey, P. L., Prowse, S. J., and Jenkin, C. R. (1978) *Immunochemistry* **15**, 429–436  
 Falk, K., Röttschke, O., Stevanovic, S., Jung, G., and Rammensee, H.-G. (1991) *Nature* **351**, 290–296  
 Feinberg, A. P., and Vogelstein, B. (1983) *Anal. Biochem.* **132**, 6–13  
 Frelinger, J. A., Gotch, F. M., Zweerink, H., Wain, E., and McMichael, A. J. (1990) *J. Exp. Med.* **172**, 827–835  
 Godeau, J.-F. (1990) in *Transfert et expression de gènes dans les cellules de mammifères* (Malissen, B., ed) pp. 33–48, Paris, Les Editions INSERM  
 Godeau, J.-F., Casanova, J.-L., Fairchild, K. D., Saucier, C., Delarbre, C., Gachelin, G., and Kourilsky, P. (1991) *Res. Immunol.* **142**, 409–416  
 Godeau, J.-F., Casanova, J.-L., Luescher, I. F., Fairchild, K. D., Delarbre, C., Saucier, C., Gachelin, G., and Kourilsky, P. (1992) *Int. Immunol.* **4**, 265–275  
 Harlow, E., and Lane, D. (1988) *Antibodies: A Laboratory Manual*, Cold Spring Harbor Laboratory, Cold Spring Harbor, NY



- Huston, J. S., Levinson, D., Mudgett-Hunter, M., Tai, M.-S., Novotny, J., Margolies, M. N., Ridge, R. J., Bruccoleri, R. E., Haber, E., Crea, R., and Oppermann, H. (1988) *Proc. Natl. Acad. Sci. U. S. A.* **85**, 5879-5883
- Jardetzky, T. S., Lane, W. S., Robinson, R. A., Madden, D. R., and Wiley, D. C. (1991) *Nature* **353**, 326-329
- Kast, W. M., Offringa, R., Peters, P. J., Voordouw, A. C., Meloen, R. H., A. J., v.d. E., and Melief, C. J. M. (1989) *Cell* **59**, 603-614
- Kornfeld, R., and Kornfeld, S. (1985) *Annu. Rev. Biochem.* **54**, 631-664
- Krangel, M. S., Orr, H. T., and Strominger, J. L. (1979) *Cell* **18**, 979-991
- Kvist, S., and Hammann, U. (1990) *Nature* **348**, 446-448
- Kyhse-Andersen, J. (1984) *J. Biochem. Biophys. Methods* **10**, 203-209
- Laemmli, U. K. (1970) *Nature* **227**, 680-685
- Luckow, V. A., and Summers, M. D. (1989) *Virology* **170**, 31-39
- Luescher, I. F. (1987) *Electrophoresis* **8**, 508-513
- Luescher, I. F., Loez, J. A., Malissen, B., and Cerottini, J.-C. (1992) *J. Immunol.* **148**, 1003-1011
- Luescher, I. F., Romero, P., Cerrotini, J.-C., and Maryanski, J. L. (1991) *Nature* **351**, 72-74
- Lurquin, C., Van Pel, A., Mariame, B., De Plaen, E., Szikora, J. P., Janssens, C., Reddehase, M. J., Lejeune, J., and Boon, T. (1989) *Cell* **58**, 293-303
- Maeda, S. (1989) *Annu. Rev. Entomol.* **34**, 351-372
- Margulies, D. H., Ramsey, A. L., Boyd, L. F., and McCluskey, J. (1986) *Proc. Natl. Acad. Sci. U. S. A.* **83**, 5252-5256
- Matsudaira, P. (1987) *J. Biol. Chem.* **262**, 10035-10038
- Matsura, Y., Posee, R. D., Overton, H. A., and Bishop, D. H. L. (1987) *J. Gen. Virol.* **68**, 1233-1250
- Merrifield, R. B. (1986) *Science* **232**, 341-347
- Miller, L. K. (1988) *Annu. Rev. Microbiol.* **42**, 177-199
- Mottez, E., Jaulin, C., Godeau, J.-F., Choppin, J., Lévy, J.-P., and Kourilsky, P. (1991) *Eur. J. Immunol.* **21**, 467-471
- Natori, T., Tanigaki, N., and Pressman, D. (1976) *J. Immunogenet.* **3**, 123-134
- Novotny, J., Ganju, R. K., Smiley, S. T., Hussey, R. E., Luther, M. A., Recny, M. A., Siliciano, R. F., and Reinhertz, E. L. (1991) *Proc. Natl. Acad. Sci. U. S. A.* **88**, 8646-8650
- Nutchern, J. G., Bonifacio, J. S., Biddison, W. E., and Klausner, R. D. (1989) *Nature* **339**, 223-226
- Owen, M. J., Kissonerghis, A.-M., and Lodish, H. F. (1980) *J. Biol. Chem.* **255**, 9678-9684
- Ozato, K., Hansen, T. H., and Sachs, D. H. (1980) *J. Immunol.* **125**, 2473-2477
- Reed, C. R., and Mann, D. A. (1985) *Nucleic Acids Res.* **13**, 7207-7220
- Rock, K. L., Gamble, S., Rothstein, L., Gramm, C., and Benacerraf, B. (1991a) *Cell* **65**, 611-620
- Rock, K. L., Gamble, S., Rothstein, L. E., and Benacerraf, B. (1991b) *Proc. Natl. Acad. Sci. U. S. A.* **88**, 301-305
- Romero, P., Corradin, G., Luescher, I. F., and Maryanski, J. L. (1991) *J. Exp. Med.* **174**, 603-612
- Romero, P., Maryanski, J. L., Corradin, G., Nussenzweig, R., Nussenzweig, V., and Zavala, F. (1989) *Nature* **341**, 323-326
- Rothbard, J. B., and Geffer, M. L. (1991) *Annu. Rev. Immunol.* **9**, 527-563
- Sambrook, J., Fritsch, E. F., and Maniatis, T. (1989) *Molecular Cloning: A Laboratory Manual*, 2nd Ed., Cold Spring Harbor Laboratory, Cold Spring Harbor, NY
- Saper, M. R., Bjorkman, P. J., and Wiley, D. C. (1991) *J. Mol. Biol.* **219**, 277-319
- Schneck, J., Maloy, W. L., Coligan, J. E., and Margulies, D. H. (1989) *Cell* **56**, 47-55
- Schneider, C., Newman, R. A., Sutherland, R., Asser, U., and Greaves, M. F. (1982) *J. Biol. Chem.* **257**, 10766-10769
- Sege, K., Rask, L., and Peterson, P. A. (1981) *Biochemistry* **20**, 4523-4530
- Sibille, C., Chomez, P., Wildmann, C., Van Pel, A., De Plaen, E., Maryanski, J. L., de Bergeyck, V., and Boon, T. (1990) *J. Exp. Med.* **172**, 35-45
- Silver, M. L., Parker, K. C., and Wiley, D. C. (1991) *Nature* **350**, 619-622
- Stern, L. J., and Wiley, D. C. (1992) *Cell* **68**, 465-477
- Townsend, A., and Bodmer, H. A. (1989) *Annu. Rev. Immunol.* **7**, 601-624
- Townsend, A., Elliott, T., Cerundolo, V., Foster, L., Barber, B., and Tse, A. (1990) *Cell* **62**, 285-295
- Townsend, A., Öhlén, C., Bastin, J., Ljunggren, H. G., Foster, L., and Kärre, K. (1989) *Nature* **340**, 443-448
- Townsend, A. R. M., Rothbard, J., Gotch, F. M., Bahadur, G., Wraith, D., and McMichael, A. J. (1986) *Cell* **44**, 959-965
- Yewdell, J. W., and Bennink, J. R. (1989) *Science* **244**, 1072-1075