



Science Arts & Métiers (SAM)

is an open access repository that collects the work of Arts et Métiers ParisTech researchers and makes it freely available over the web where possible.

This is an author-deposited version published in: <https://sam.ensam.eu>
Handle ID: <http://hdl.handle.net/10985/9778>

To cite this version :

Mohamed Aymen SAHNOUN, Hector ROMERO UGALDE, Jean-Claude CARMONA, Julien GOMAND - Maximum power point tracking using P&O control optimized by a neural network approach: a good compromise between accuracy and complexity - Energy Procedia - Vol. 42, n°1, p.650-659 - 2013

Any correspondence concerning this service should be sent to the repository

Administrator : archiveouverte@ensam.eu



The Mediterranean Green Energy Forum 2013, MGEF-13

Maximum power point tracking using P&O control optimized by a neural network approach: a good compromise between accuracy and complexity

Mohamed Aymen Sahnoun^a, Hector M. Romero Ugalde^{a*}, Jean-Claude Carmona^a, Julien Gomand^a

^aLaboratoire LSIS, Equipe INSM, 2, cours des Arts et Métiers, Aix-en-Provence 13617, France

Abstract

In the field of power optimization of photovoltaic panels (PV), there exist many maximum power point tracking (MPPT) control algorithms, such as: the perturb and observe (P&O) one, the algorithms based on fuzzy logic and the ones using a neural network approaches. Among these MPPT control algorithms, P&O is one of the most widely used due to its simplicity of implementation. However, the major drawback of this kind of algorithm is the lack of accuracy due to oscillations around the PPM. Conversely, MPPT control using neural networks have shown to be a very efficient solution in term of accuracy. However, this approach remains complex.

In this paper we propose an original optimization of the P&O MPPT control with a neural network algorithm leading to a significant reduction of the computational cost required to train it, ensuring a good compromise between accuracy and complexity. The algorithm has been applied to the models of two different types of solar panels, which have been experimentally validated.

© 2013 The Authors. Published by Elsevier Ltd.

Selection and peer-review under responsibility of KES International

Keywords: Photovoltaic module; P&O control; MPPT control; neural network

1. Introduction

In recent years, there has been an increasing interest in the use of renewable energies. In particular, the solar one is becoming increasingly adopted due to the decrease of the fossil energies, and to their environmental impact. In effect renewable energies are known as "clean" and favorable to the environment. One of the existing solutions to improve the solar energy use consists in exploiting the photovoltaic panels at an optimal rate. Hence, an adapted DC/DC converter and appropriate control laws of MPPT should be added.

There is a large volume of published studies describing the MPPT control algorithms. As illustrating examples, the perturb and observe (P&O) one described by [1, 2, 3], and the MPPT control one based on an incremental conductance method [2, 3]. These control laws are easy to implement and provide a

* Corresponding author. Tel.: +33 6 14 82 52 10.

E-mail address: hector@cenidet.edu.mx

significant yield when the evolution of PPM is slow. However, they are the least accurate and furthermore, they lead to a lot of oscillations and a low yield when evolution is rapid.

There is also another type of MPPT control based on a simple current control or voltage control [2, 3]. There are simple method, easy to implement and requiring only one sensor. But they are less accurate and it is necessary to disconnect the load for each measurement.

Other control increasingly used such as the MPPT control based on fuzzy logic [6, 7] and the MPPT control based on a neural network approach [3, 8]. These methods are more accurate and they can work with imprecise inputs, can handle nonlinearity and are very efficient in changing climatic conditions. However, they are more complex and have relatively large energy consumption.

It is well known in neural networks that numerous neurons favor a better accuracy but lead to more complexity too [9, 10]. Therefore, different works are issued to find the best trade-off between the model complexity and approximation accuracy by finding the “optimal” number of neurons. “Trial and error” is one of these techniques [11, 12]. Pruning based techniques have been successfully used for structural optimization [11, 13]. In this approach, besides optimizing the number of neurons, the connections between the neurons are also optimized. More recently, other evolutionary techniques have been employed in order to derive “optimal” structures: For example, genetic algorithms (GAs) [14], dissimilation particle swarm optimization (PSO) [15] and genetic programming (GP) [16].

As the pruning approach, the previously outlined techniques based on the evolution of the neural network, have been successfully applied for structural optimization, but their main disadvantage is the excessive requirement of time to find the most convenient number of neurons, since the neural network is trained each time the model is modified or restructured [17]. Moreover, to solve the problem of finding the best trade-off between model complexity and model accuracy, rather subjective criterion is always used to decide whether the evolution of the neural network is appropriate and sufficient.

Other techniques trying to solve the same problem are based on the design of the neural network. In [18], a novel time-delay recurrent neural network (TDRNN) is proposed to generate a simple structure. In [10] a neural network using a competitive scheme is proposed in order to provide an effective method with less network complexity. In [19] a pipeline bilinear recurrent neural network (PBLRNN) is proposed in order to reduce both the model and computational complexity of a bilinear recurrent neural network (BLRNN). In [20] a model complexity reduction approach based on two design assumptions is proposed. The reduction approach transforms a complex neural network into a simplest one preserving the same accuracy.

In the same vein, to avoid the disadvantages of the “architecture evolution techniques” and with the conviction that the improvement of the quality of a neural network is linked to a suitable design, we decided to tackle the problem by applying the model reduction approach firstly presented in [20]. The purpose of this study is to improve the accuracy of the P&O MPPT control with an optimized neural network algorithm and to lead to a good compromise between complexity and accuracy.

The paper is organized follows. The first section presents a model of photovoltaic module. This model is validated by experiment, on two solar panels. The second section describes the P&O MPPT control and its optimization algorithm. In this section we propose a new optimization algorithm based on a neural network in addition to a model reduction procedure. The last section discusses the performance of the proposed algorithm and presents a comparison with the P&O MPPT algorithm.

Nomenclature

ΔV	Value of voltage variation
a	The diode constant
G	The irradiation on the device surface
G_n	The nominal irradiation
I_0	The diode saturation current
I_{pv}	Photovoltaic (PV) current
I_{pv0}	Photo-current
I_{pvn}	Light-generated current at the nominal condition (usually 25 °C and 1000 W/m ²)
K	Boltzmann constant
K_i	Current coefficient
N_s	Number of cells connected in series
P_{pv}	Photovoltaic (PV) power
q	The electron charge
R_s	The equivalent series resistance of the array
R_p	The equivalent parallel resistance of the array
T	The temperature of the PV cell
T_n	The nominal temperature
V_{pv}	Photovoltaic (PV) voltage

2. PV modeling

The two most encountered models of photovoltaic modules are the single diode [4] model and the double diode model [5]. In this study, a single diode model is used because it ensures a good compromise between simplicity and accuracy.

2.1. Single diode model of a PV

The equivalent circuit of a solar cell (see Fig. 1) is composed of a current source representing the photo current, a simple diode representing the dark current and series and parallel resistors representing losses occurring in the cell.

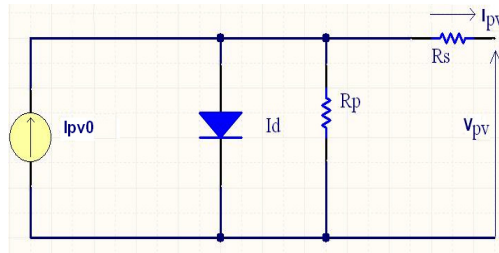

Fig. 1. Single-diode equivalent circuit of a solar cell

Equation (1) is derived from this equivalent circuit. The relation between the current and the voltage is given by the following equation:

$$I_{pv} = I_{pv0} - I_0 \left[\exp\left(\frac{V_{pv} + R_s I_{pv}}{V_t a}\right) - 1 \right] - \frac{V_{pv} + R_s I_{pv}}{R_s} \tag{1}$$

The photocurrent depends on the solar radiation and the temperature as shown in equation (2):

$$I_{pv0} = (I_{pvn} + K_i \cdot (T - T_n)) \frac{G}{G_n} \tag{2}$$

With:

$$V_t = \frac{N_s \cdot K \cdot T}{q} \tag{3}$$

2.2. Experimental validation of the PV model

The photovoltaic module model is simulated in Matlab Simulink. This simulation model presents two inputs solar irradiation and temperature to generate the voltage and current of the module.

Then, the model is validated by experimental measurements made on a solar panel Sharp series NU48. The experimental characteristic $I_{pv}(V_{pv})$ versus $P_{pv}(V_{pv})$ and the simulated one in Matlab are shown in Fig. 2. The measurements of current and voltage are taken with a temperature 21°C and irradiance of 301W/m². These curves are almost identical with minimal errors. In addition, we calculated the average error MBE [2] which is equal to 0.23 for the photovoltaic panel.

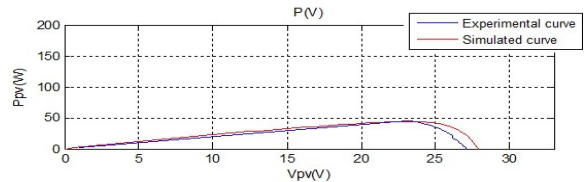
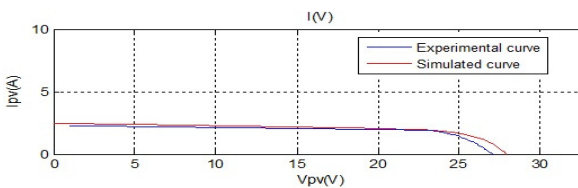

Fig. 2. I_{pv} (V_{pv}) versus P_{pv} (V_{pv}) experimental curves of simulation and experimented model

$$MBE = \frac{\sum_{i=1}^N (y_i - x_i)}{N} \tag{4}$$

Where x_i (resp y_i) are simulated photovoltaic current (resp experimental photovoltaic current) and i is the measurement point.

3. Optimization control algorithm using neural network

3.1. Basic P&O MPPT

The MPPT control is based on an adaptive control algorithm trying to maintain the photovoltaic module in its maximum power point (MPP) [1].

To reach this objective, the first step consists in taking measurements of the voltage (V_{pv}) and the current (I_{pv}) of the photovoltaic module with fixed temperature and irradiance. These measurements are taken at a time t_k and compared with the receding measured quantities at t_{k-1} . Then the power (P_{pv}) can be calculated at t_k and compared to the one calculated at t_{k-1} . The result of this comparison gives the direction of the control and the duty cycle (α) applied to the DC/DC converter as shown in Fig. 3.

The principle of P&O algorithm [1, 2, 3], presented by the flow chart Fig. 4 consists in creating a perturbation, varying the voltage and observing the resulting variation of the power. Then, from the increment and decrement of the voltage and according to the increase or decrease of the power, we can find the operation point corresponding to the maximum power.

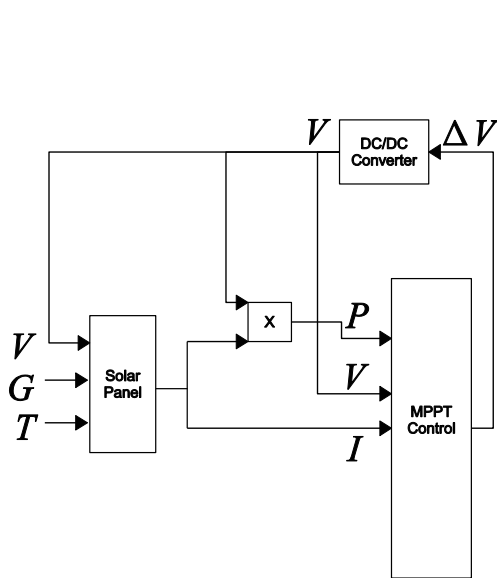

Fig. 3. The principle of MPPT control

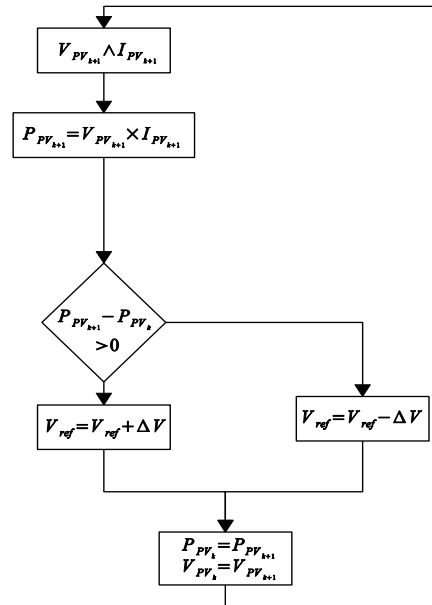

Fig. 4. The principle of P&O MPPT control

The P&O MPPT control is one of the most used algorithm due to its simplicity of implementation and its low-cost. However, it is not quite efficient in terms of accuracy since it does not reach the maximum power point as it oscillates around this point. This problem is due to the strategy chosen for the voltage determination, namely a constant gain approach ΔV as shown in Fig. 3. There are various methods and algorithms to solve this problem as the variable gain approaches. In the next section, two of these algorithms are presented.

3.2. Optimization of P&O MPPT: search then convergence algorithm

There are different algorithms in the literature used to optimize the P&O MPPT control and to improve its accuracy. Let us introduce the “Search then convergence”. For more details, see [21].

$$\Delta V_{k+1} = \frac{(\Delta V_k)}{1 + \left(\frac{K}{K_0}\right)} \quad (5)$$

With $K_0 = \frac{100}{3}$.

From equation (5) we can deduce that when K increases the value of ΔV decreases. In effect we retrieve here the interest of such a “decreasing gain” type algorithm. At the beginning, the value ΔV is supposed far of its optimal value and it should be adapted as fast as possible $\Delta V(k+1) = \Delta V(k)$. As $K \rightarrow \infty$, the parameter is supposed to be near its optimal value. Then, the parameter should be modified slowly ($\Delta V \rightarrow 0$) in order to improve the convergence.

In the same vein, we propose the following linear algorithm which is more simple, but with a restrictive accuracy as we will see in Section 4.

$$\Delta V_{k+1} = \Delta V_k - [(\Delta V_k)X] \quad (6)$$

$X = 0.10$;

3.3. Optimization of P&O MPPT with neural network algorithm

Now let us introduce the proposed neural network algorithm used in our improved approach. The neural network used to estimate and to vary the variable ΔV of the P & O MPPT control. This variation allows reducing the oscillation around the maximum power. As shown in the flowchart of Fig. 5 the algorithm takes into account the variation of the power, the current and the voltage of the photovoltaic module. The variable ΔV that gives the maximum power is calculated due to the learning algorithm and the changing weight of neurons.

The mathematical representation of this neural network is:

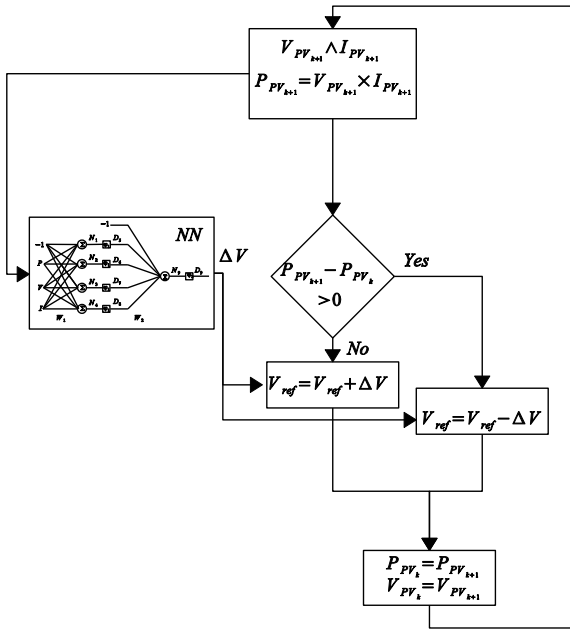

Fig. 5. The principle of P&O MPPT algorithm optimized by a neural network

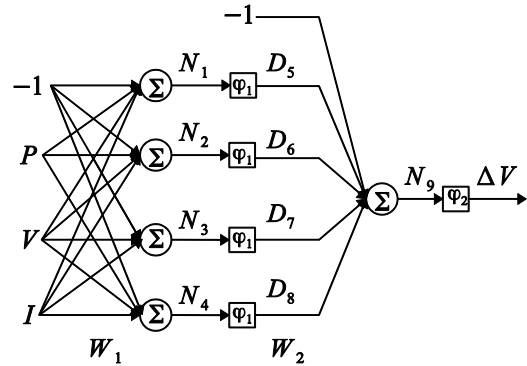

Fig. 6. Diagram of neural network hierarchy

$$\Delta V = \rho_2(Nq)$$

$$N_q = \sum_{i=1}^m V_i \rho_1(N_i) + V_n \tag{7}$$

$$N_i = X \cdot W_i + \theta_i$$

According to the Assumption proposed in [20], i.e.:

Assumption 1: At least one layer should have all its activation functions chosen as linear.

We choose $\rho_1(T)=T$ (linear) and $\rho_2(T)=\text{sigmoid}(T)$ in Fig. 6.

Moreover, we suppose:

Assumption 2: The designer should select the initial condition of the synaptic weights equals group by group, i. e., $W_1(0) = W_j(0)$, $V_1(0) = V_j(0)$ with $j=1, \dots, n$, where nn is the number of neuron.

Even if this is not a classical way to choose the initial conditions of the synaptic weights, full experiments, detailed in [20], demonstrated their validity, without a significant loss of generality in practical applications.

According to the following result presented in details in [20]:

Theorem: Consider the neural network whose architecture 2nn-1 is expressed in equation (8) and depicted in Fig. 6, if Assumptions 1 and 2 are fulfilled, then such neural network can be reduced into a 1-1 equivalent architecture.

Let us present the reduction procedure: The first step of the procedure is to train the neural network under the two preceding design assumptions. In this paper, the neural network is trained with the classical steepest descent algorithm. Once the neural network is trained, we obtain:

$$\Delta V = \text{sigmoid}(Nq)$$

$$N_q = \sum_{i=1}^m V_i(N_i) + V_n \tag{8}$$

$$N_i = X.W_i + \theta_i$$

Notice that, in equation (8), the final values of the synaptic weights are $W_i(0) = W_j(0)$ and $V_i(0) = V_j(0)$ with $j=1, \dots, n$. Then, we can transform (8) in (9).

$$\Delta V = \text{sigmoid}(nn \times V_1(XW_1 + \theta_1) + V_h) \tag{9}$$

The reader shall remark that in equation (9) we do not need to train the nn W_i and V_i synaptic weights, since the final values are equal group by group. In this sense, we reduce the computational cost required to train the complex neural network, as we keep the same accuracy.

4. Results : Comparison between the different control algorithms

In these experiments, the temperature T and the irradiance G are held constant. We choose the values of standard conditions: $T_n = 25^\circ \text{C}$ and $G_n = 1000 \text{W/m}^2$. The purpose of these simulations tests is to show the evolution of power and the pursuit of maximum operating power of the photovoltaic module in order to better compare the performance, of 4 different P&O MPPT algorithms.

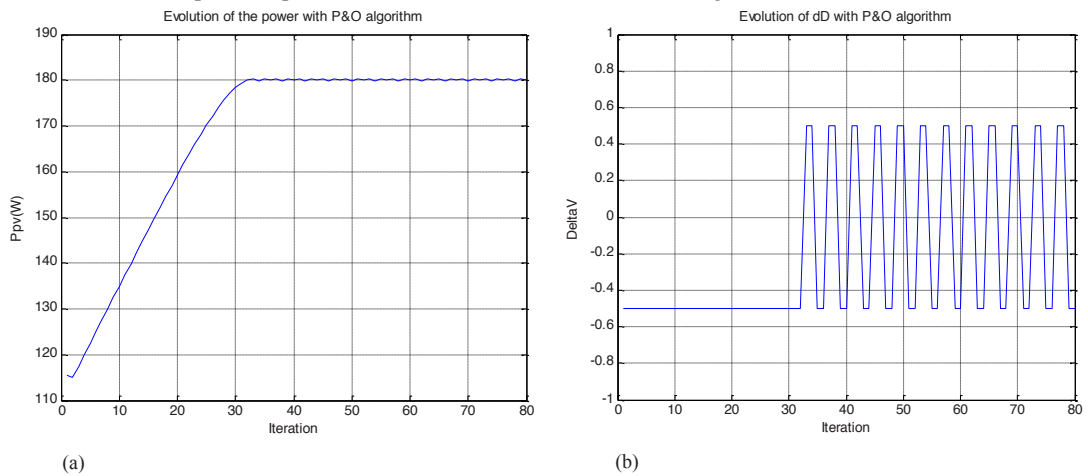

Fig. 7. P&O MPPT control (a) Evolution of P_{pv} . (b) Evolution of ΔV

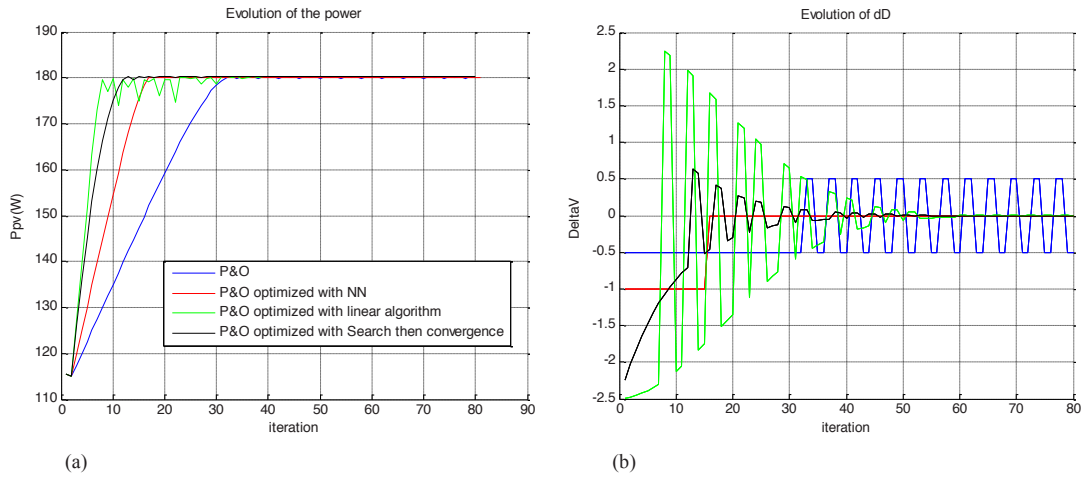

Fig. 8. Four MPPT control algorithms (a) Evolution of P_{pv} . (b) Evolution of ΔV

Fig. 7a shows the evolution of the power P_{pv} using a simple P&O algorithm. Classically, we can see the presence of oscillations around the maximum power and this is due to the change in voltage by the use of a fixed gain as shown in Fig 7b.

Fig. 8a shows the evolution of the power P_{pv} for the following commands: The classic P&O MPPT control, the P&O control with an optimized algorithm “search then convergence”, the P&O control with a linear algorithm and the P&O MPPT control with an algorithm of optimization based on neural network.

The results show that the three optimization algorithms of the P&O MPPT control give faster responses and less oscillation around the maximum power than the basic P&O control. The P&O control optimized by a neural network is not the fastest one (Fig. 8a). However, it has the highest accuracy since it leads to the best minimization of the oscillations, as shown in Fig.8b. Another advantage of the neural algorithm is that we do not need to choose a good initial value for ΔV leading to a compromise between convergence speed and accuracy unlike the other control algorithms.

The P&O control optimized by a neural network is tested and validated also by varying the irradiance. Fig. 9 proves that this optimized control allows finding the new maximum power point for each variation of the irradiance ensuring greater accuracy compared to the P&O control.

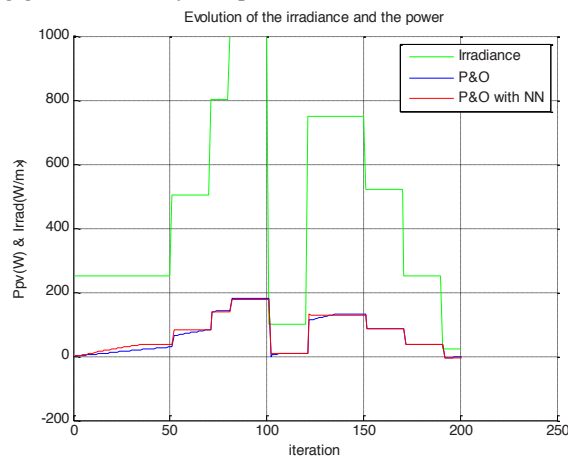

Fig. 9. Evolution of the irradiance and P_{pv} with the P&O control and the P&O optimized by a neural network control

5. Conclusion

In this paper we proposed a new optimization algorithm for the classic P&O MPPT control of the PV, based on a neural network approach in order to improve its accuracy. The results achieved by this algorithm are more efficient than those obtained with the classical P&O algorithm and more accurate than the two other classical algorithms of optimization (Linear and Search then convergence). Even if, it is not the fastest MPPT control approach, this is not really a prohibitive drawback due to the slow dynamics of the photovoltaic system. The proposed algorithm has demonstrated its robustness for variation of the irradiance even with a sudden drop of the irradiance. Taking into account the reduction of the complexity, the proposed neural network leads to a good compromise between accuracy and complexity. Even more, in a future work, the same neural network architecture is used in a MPPT control scheme (without using the P&O approach), in order to further improve the accuracy and to reduce the complexity of the MPPT control of the PV.

References

- [1] Kassmi K, Hamdaoui M, Olivieri F, Conception et modélisation d'un système photovoltaïque adapté par une commande MPPT analogique. *Revue des Energies Renouvelables* 2007 ; 10 :451 – 462 ;
- [2] Boitier V, Maussion P, Cabal C, Recherche du maximum de puissance sur les générateurs photovoltaïques. *Revue 3E.I* 2008 ; 54 :90-96 ;
- [3] Cabal C, *Optimisation énergétique de l'étage d'adaptation électronique dédié à la conversion photovoltaïque*, thèse de l'Université Toulouse III – Paul Sabatier 2008
- [4] Gradella M, Villalva, Jonas R G, and Ernesto R F, Comprehensive Approach to Modeling and Simulation of Photovoltaic Arrays, in :*IEEE Intern. Conf. On transaction on power electronics*; 2009, 24
- [5] : Notton G, Caluianu I, Colda I, Caluianu S, Influence d'un ombrage partiel sur la production électrique d'un module photovoltaïque en silicium monocristallin, *Revue des Energies Renouvelables* 2010 ; 13 :49 – 62 ;
- [6]: Aït Cheikh MS, Larbes C, Tchoketch GF Kebir and Zerguerras A, Maximum power point tracking using a fuzzy logic control scheme, *Revue des Energies renouvelables* 2007 ; 10 :387 – 395;
- [7]: Hatti M, Contrôleur flou pour la poursuite du point de puissance maximum d'un système photovoltaïque In : JCG'08 conf ; 2008, p. 16 -17
- [8] Mehran H and Alireza Y, New MPPT Controller Design for PV Arrays Using Neural Networks. In ISNN 2009 intern. conf on Neural Networks: Advances in Neural Networks ; 2009, p.1050 - 1058
- [9] Khalaj G, Yoozbashizadeh H, Khodabandeh A, Nazari A. Artificial neural network to predict the effect of heat treatments on Vickers microhardness of low-carbon Nb microalloyed steels. *Neural Computing and Applications* 2013; 22: 879-888.
- [10] R. Chen. Reducing network and computation complexities in neural based real-time scheduling scheme. *Applied Mathematics and Computation* 2011; 217, 13:6379 - 6389.
- [11] Bebis G, Georgiopoulos M. Feed-forward neural networks: why network size is so important. *IEEE Potentials* 1994; 13: 27-31.
- [12] Zhang H, Wu W, Yao M. Boundedness and convergence of batch back-propagation algorithm with penalty for feedforward neural networks. *Neurocomputing* 2012; 89: 141-146.
- [13] Noorgard M, Ravn O, Poulsen N K, Hansen L K. *Neural Networks for Modelling and Control of Dynamic Systems*. 1st ed. Springer-Verlag London Berlin Heidelberg; 2000.
- [14] Loghmanian S, Jamaluddin H, Ahmad R, Yusof R, Khalid M. Structure optimization of neural network for dynamic system modeling using multi-objective genetic algorithm. *Neural Computing and Applications* 2011; 1-15.
- [15] Ge H, Qian K, Liang Y, Du W, Wang L. Identification and control of nonlinear systems by a dissimilation particle swarm optimization-based Elman neural network. *Nonlinear Analysis: Real World Applications* 2008; 9, 4: 1345-1360.
- [16] Coelho L, Wicthoff M. Nonlinear identification using a B-spline neural network and chaotic immune approaches. *Mechanical Systems and signal Processing* 2009; 23, 8: 2418-2434.
- [17] Subudhi B, Jenab D. A differential evolution based neural network approach to nonlinear system identification, *Applied Soft Computing* 2011; 11, 1: 861 - 871.
- [18] Ge H, Du W, Qian F, Liang Y. Identification and control of nonlinear systems by a time-delay recurrent neural network. *Neurocomputing* 2009; 72, 13-15: 2857-2864.
- [19] Haiquan Zhao, Xiangping Zeng, Zhengyou He. Low-Complexity Nonlinear Adaptive Filter Based on a Pipelined Bilinear Recurrent Neural Network. *IEEE Transactions on Neural Networks* 2011; 22, 9: 1494-1507.
- [20] Romero-Ugalde H M, Carmona J-C, Alvarado V M, Reyes-Reyes J. Neural network design and model reduction approach for black box nonlinear system identification with reduced number of parameters. *Neurocomputing* 2013; 101:170-180.
- [21] A. Cichocki, R. Unbehauen. *Neural Networks for Optimization and Signal Processing*. 1st ed. John Wiley and Sons Ltd; 1993.