



Science Arts & Métiers (SAM)

is an open access repository that collects the work of Arts et Métiers ParisTech researchers and makes it freely available over the web where possible.

This is an author-deposited version published in: <https://sam.ensam.eu>
Handle ID: <http://hdl.handle.net/10985/9939>

To cite this version :

Anne BOMONT-ARZUR, Mario CONFENTE, Olivier BOMONT, Emmanuel SCHNEIDER, Christophe LESCALIER, Anne BOMONT-ARZUR - Influence of material structure on deep hole machinability of Super High Strength Steels - International Journal of Machining and Machinability of Materials - Vol. 2, n°2, p.282-298 - 2007

Any correspondence concerning this service should be sent to the repository

Administrator : archiveouverte@ensam.eu



INFLUENCE OF MATERIAL STRUCTURE ON DEEP HOLE MACHINABILITY OF SUPER HIGH STRENGTH STEELS- APPLICATION TO CRANKSHAFT MANUFACTURING METHODOLOGY, RESULTS AND ANALYSIS

Anne BOMONT-ARZUR¹, Mario CONFENTE¹,
Olivier BOMONT², Emmanuel SCHNEIDER², Christophe LESCALIER²

¹Mittal Steel Europe R & D, 57 360 Amnéville, France

² LGIPM, Dept. of Manufacturing Engineering, ENSAM, 57000 Metz, France

anne.bomont-arzur@mittalsteel.com

Abstract: The gain of productivity in machining is generally sought through tools and/or cutting conditions optimization however an increase in productivity is achievable too through the work-material optimization. The metallurgical structure as well as the chemical composition of steels widely influence their ability to be machined. Mittal Steel Europe R & D develops new steel grades such as the Super High Strength Steels whose tensile stresses may reach 1000 or 1200 MPa. A cooperative research program between Mittal Steel Europe R&D and ENSAM tends to propose a methodology able to sort the steel grades in terms of ability to be manufactured (in forging and machining). This study focuses on such an industrial application : the heavy vehicles crankshaft manufacturing. The operation investigated consists in deep hole drilling and is concerned with the lubrication holes. This paper proposes some relevant criteria to compare the different steel grades and/or structures. Some experimental results are proposed.

Keywords: Deep hole drilling, machinability, gundrill toolwear, Super High Strength Steel (SHSS); bainite.

UNITS

Designation	Unit	Name
C, N, X		Taylor's Coefficients
d	mm	Drill diameter
f	mm/rev	Feed
F _c	N	(tangential) Cutting force
F _x , F _y , F _z	N	Forces measured by the Kistler table
HV1		Hardness
k _C	N/mm ²	Specific cutting pressure
KT	μm	Tool wear on the rake face (crater depth)
L _g	mm	Length drilled until tool wear criterion is reached
l _p	mm	Hole depth
M _z	N.m	Drilling torque
P _c	W	Cutting power
T	min	Tool life
VB	μm	Tool wear on the flank face (flank wear)
V _c	m/min	Cutting speed

1 INTRODUCTION

Manufacturing processes tend to become more and more complex. Their understanding includes the knowledge of both the action of one process on the product and the influence of one process on the others. The present study focuses on the deep hole drilling operations encountered in heavy vehicles crankshafts manufacturing (Figure 1). These parts are forged first and then drilled. The holes help to supply lubricant to the rotating part of the shafts.

The goals of these investigations are first to check the feasibility of the deep hole drilling operation and then to optimize the cutting conditions in terms of productivity and costs. The method used follows the recommendations of an European standard, the "Couple Outil - Matière" (NF E 66-520) [AFNOR, 2000] [Vigneau, 1999]. COM experiments enable to define the operating range, the whole cutting conditions fulfilling constraints for an association tool / workpiece / operation.

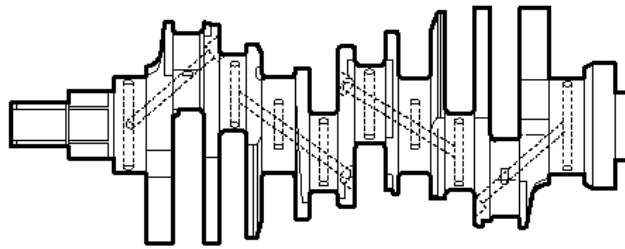

Figure 1 : Scheme of a crankshaft and its deep holes devoted to the lubrication

During experiments both the drilling forces, the drilling torque and the electrical power consumed by the spindle motor are measured. Those two sensors (i.e. dynamometric table, power analyzer) are listed as necessary equipment in the COM standard. The comparison of the two recordings enables to confirm the overall trends. Furthermore the power measurements are useful to provide some relevant information about the tool wear process. The dispersions of the holes have also been measured - by mean of a coordinate measuring machine.

The study focuses on the comparison of Super High Strength Steel grades (SHSS) in deep hole drilling. A reference steel grade (34CrNiMo6) is compared with a new micro alloyed steel (Micro Alloyed SHSS). The reference grade is quench-tempered and reaches a hardness of Hv1 = 310 – 340. The new steel grade is studied under 3 metallurgical structures: bainitic (Hv1 = 340 - 360), combined (Hv1 = 320 - 390) and perlitic (Hv1 = 240 -260). It presents the advantage of not requiring specific thermal treatment (Figure 2). Combined structure is made up of about 40% perlite and 60% bainite.

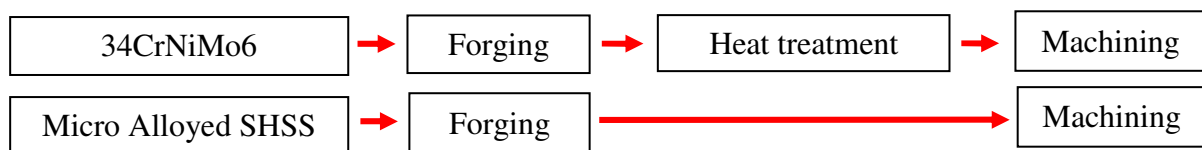

Figure 2 : Micro Alloyed SHSS manufacturing process towards reference grade one

The present paper describes the global analytical methodology employed ([Bomont et Al., 2004] [Bomont et Al., 2004(2)] [Resiak et Al., 2005]), after an introduction to deep hole problematic and details on the means employed. Then, it deals with the results obtained thanks to the methodology.

2 DEEP HOLE DRILLING

Deep holes are defined by a high ratio between hole depth and hole diameter. Deep-hole drilling is the preferred method for drilling hole depths of more than 10 times the diameter up to 150 times diameter. Two tool solutions are proposed: inserts drills and gundrills (under 40 mm diameter). One of

the major problems encountered in deep hole drilling consists in evacuating chips from the cutting zone. Internal high pressure lubricant supply is then widely used to overcome this problem therefore drilling conditions are still optimized to produce highly fragmented chips.

Many researchers have contributed to deep hole drilling optimization through tool geometry [Astakhov, 1995] [Richardson et Al., 2000] tool wear process [Gao et Al., 2000] [Zhang et Al., 2003] and vibration analysis [Astakhov, 1995] [Weinert et Al., 2005].

The experiments consist in drilling 7 mm diameter, up to 100 mm depth holes. The tools used are Ø7 mm ×230 mm BOTEK gundrills. The tip sharpening geometry is called "flat standard". The tool material is an uncoated K15 micro-grain tungsten carbide.

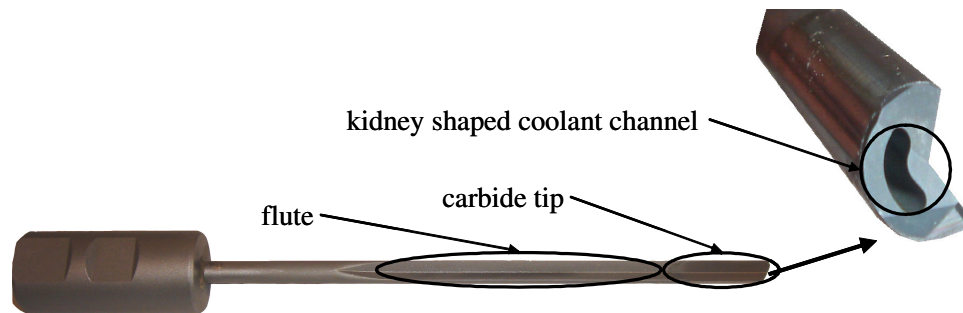

Figure 3: Scheme of a gundrill

The deep hole drilling experiments are carried out on the 4-axis numerically controlled machining centre ERNAULT FH 45. The lubricant employed is composed for 12% of SITALA D3601 (SHELL) injected at 80 bars. Cutting forces and drilling torque are measured using a Kistler 9272 4-components dynamometer. Mechanical power developed by the machine-tool spindle motor is measured using a Zimmer LMG450 power analyser.

Drilling forces may be resolved into components analysed towards gundrill geometry and drilling conditions. COM method proposes a global analysis based on the variations of the specific energy (called specific pressure) covering chip formation, chip ejection and burnishing due to pads. The specific pressure – often regarded as the mean stress on the chip/tool contact area – is usually defined using equation (1). The experimental values are also derived from the power consumed through equation (2).

$$F_c = k_c \cdot f \cdot d / 2 \quad (1) \quad P_c = \frac{k_c \times f \times d \times V_c}{240} \quad (2)$$

3 THE "COUPLE OUTIL-MATIERE" METHOD

The "Couple Outil Matière" is a standardized experimental protocol devoted to characterize the machinability [AFNOR, 2000] [Vigneau, 1999]. The experiments are to be done for each association workpiece / cutting tool / machining operation. The result is an operating range, the whole acceptable machining conditions for the association workpiece / tool / operation. A machining condition (i.e. V_c , f for a drilling operation) is regarded as acceptable when:

- k_c values are acceptable,
- chips are fragmented,
- tool wear is regular and controllable,
- holes roughness is compatible with deep hole applications,

3.1 Operating range determination

The drilling experiment protocol consists in:

- drilling a 15 mm deep and 7H7 mm diameter pilot hole,

- engaging the gundrill into the pilot hole at a low rotating frequency,
- increasing gundrill rotating frequency to reach the cutting speed,
- turning on the high pressure lubrication,
- performing the deep hole drilling operation
 - a 25 mm deep hole for the V_{cmin} or f_{min} tests,
 - a 100 mm deep hole for the wear tests,

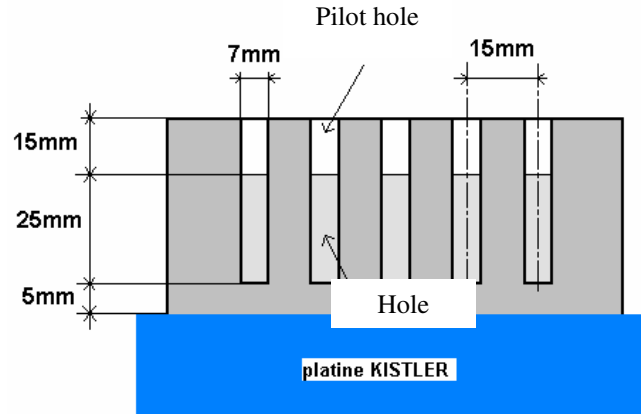

Figure 4 : Scheme of the V_{cmin} and f_{min} tests

For V_{cmin} determination, an usual feed value is used. The cutting speed varies within a large range (about from 10 to 100 m/min). k_C is computed using both equations 1 (from Kistler table measurements) and 2 (from Zimmer power analyzer measurements). V_{cmin} is defined from experimental results.

For f_{min} determination, a cutting speed is chosen that is greater than V_{cmin} about 10 m/min. The feed varies between 0,005 and 0,1 mm.

Chips are systematically collected during V_{cmin} and f_{min} experiments. Some drilling conditions generate irregular chips (non-stationary chip formation process) or long chips (potentially hard to eject from the drill tip). If so, drilling conditions are declared non-compliant for this deep-hole drilling application.

About thirty holes provide the data required to determine V_{cmin} and f_{min} on a given material. The tool wear is checked during these preliminary tests. The wear evolution is negligible.

3.2 Tool wear [Gao et Al., 2000]

Physical phenomena in tool wear (adhesion, abrasion, oxidation, diffusion) lead to an alteration of the tool geometry, and then the machined parts geometry is perturbed. The NF E 66-505 standard details how to characterize this geometry damages by mean of VB – the tool wear on the relief face – and KT – the tool wear on the rake face. These damages are shown on Figure 5 to Figure 7. The steels machinability can be compared by many ways, for our study, the chosen criteria is the tool life (hole length machined, L_g) until reaching $VB = 0.2$ mm. A modified Taylor wear model is used :

$$V_C \cdot L_g^N \cdot f^X = C \quad (3)$$

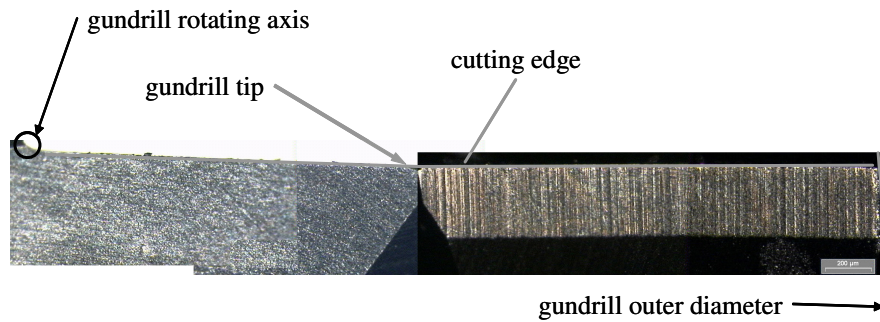

Figure 5 : Front view of a new gundrill

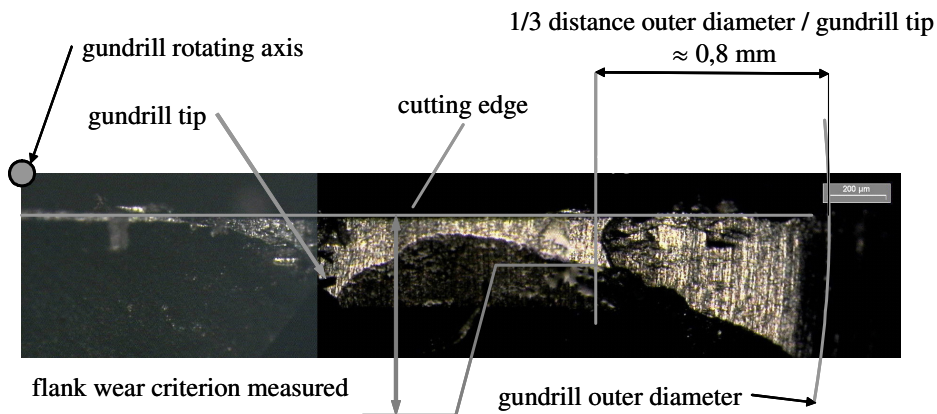

Figure 6 : The same view after 0.5 m drilled

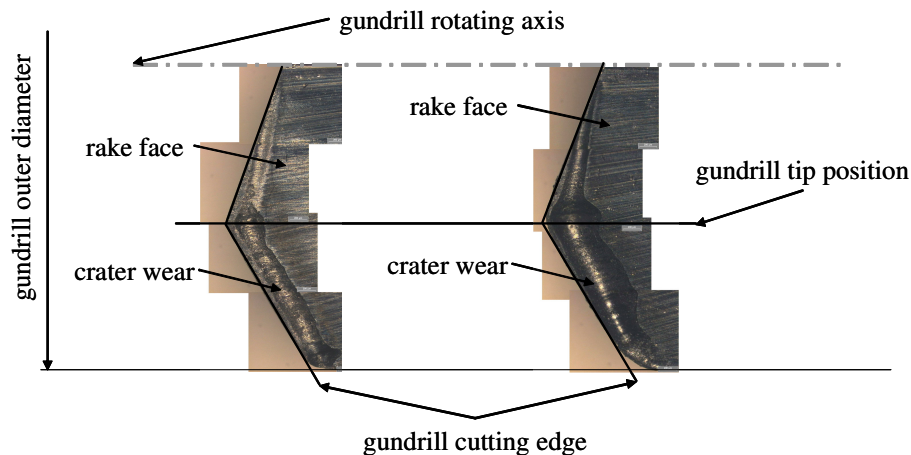

Figure 7 : KT criterion on a worn drill (1m and 3.6 m drilled)

The aim of these tests is to determine the tool wear in deep hole drilling; a depth about 100 mm (14 times the diameter) is arbitrarily chosen. A 15 mm deep pilot hole is done as before (see Figure 4). The drilling axes are perpendicular to the direction of casting. The casts are squares of 135 mm side.

Four pairs (V_c , f) from the operating range are chosen. A wear test is performed until the drills reach a flank wear VB about 0.2 mm (a linear regression is used if the value is exceeded). The total drilled length is stored. The fourth lengths are computed to provide Taylor coefficients (equation (3)). In our case, the well known Taylor equation is simplified – l_p/d being constant and the tool life T replaceable by the length machined –. This equation can be solved within Excel, considering the matrix equation of the linearized equivalent equations for the cutting conditions recorded data.

After the determination of these coefficients for each studied steel, the comparison between these steels can be done by evaluating the tool life resulting of their machining at given cutting conditions. This approach also integrates the notion of prediction of tool life. Electrical power is measured during the tool wear tests in order to know how the power varies during tool life. This is generally done in machining monitoring [Lin et Al., 1995].

4 EXPERIMENTS AND RESULTS

4.1 Minimal cutting conditions

Experiments results are drawn on Figure 8 and Figure 9. Results are synthesized on Table 1.

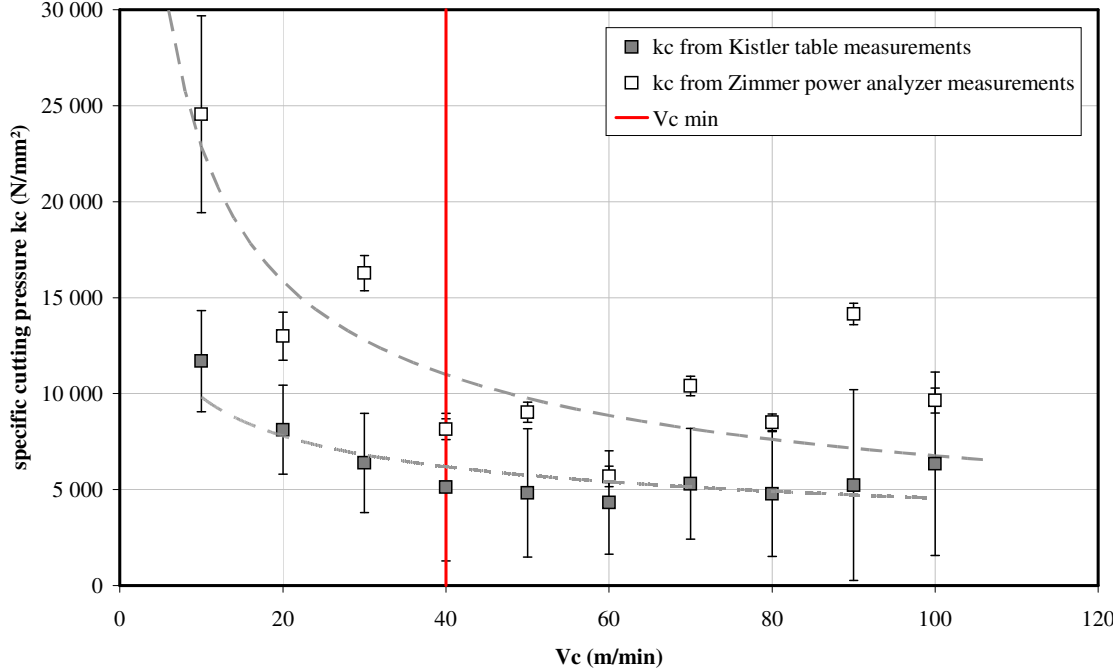

Figure 8 : Determination of $V_{c_{min}}$ for the Micro Alloyed SHSS Perlitic grade ($f = 0,03$ mm/rev)

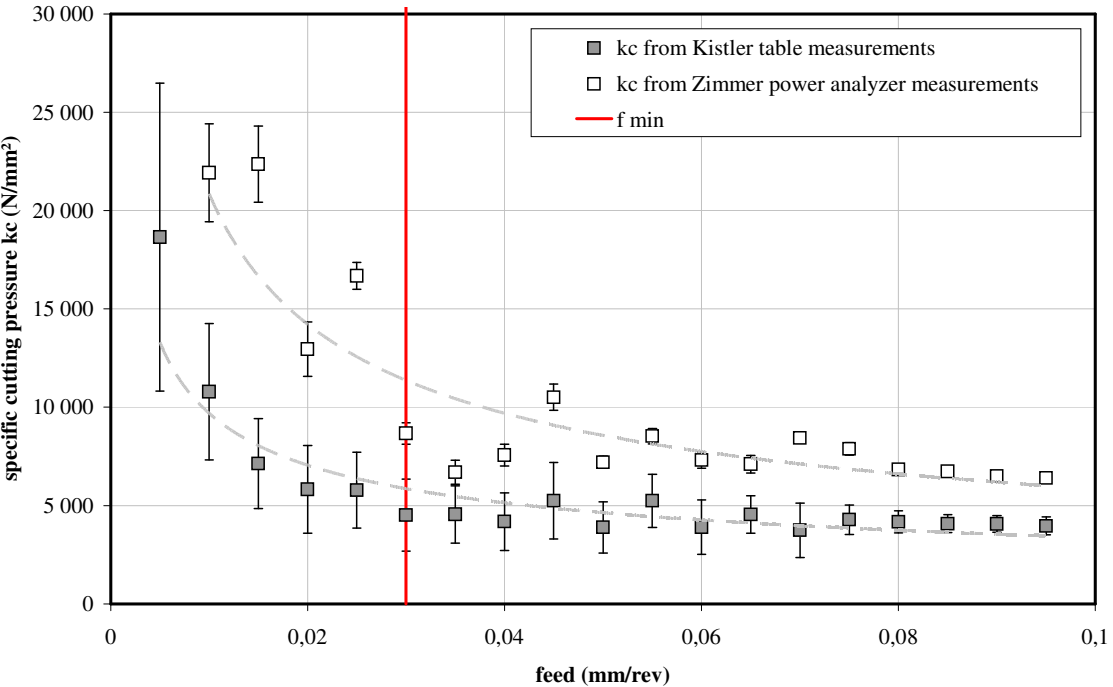

Figure 9 : Determination of f_{min} for the Micro Alloyed SHSS Perlitic grade ($V_c = 45$ m/min)

Steel grade	$V_{c_{min}}$ (m/min)	k_C (N/mm ²) at $V_{c_{min}}$	f_{min} (mm/rev)	k_C (N/mm ²) at f_{min}
Reference : A	45	4000-13000	0,03	5000-10000
Micro Aligned SHSS	Perlitic grade	40	5000-8000	0,03
	Combined grade	35	5000-13000	0,025
	Bainitic grade	30	4000	0,02

Table 1 : Synthetic table of the values $V_{c_{min}}$ and f_{min}

$V_{c_{min}}$ and f_{min} experimental values decrease with the increase in steel hardness. The reference steel grade shows the highest values and the bainitic grade the lowest. The values of k_C are sensitively equivalent at $V_{c_{min}}$ and f_{min} for the different grades. The difference between the electrical and the forces recordings is included in the standard deviations of the measurements (see vertical bars on the graphs). This difference is mainly due to the mechanical efficiency of both the machine spindle motor and gearbox unit.

As a conclusion, at given cutting conditions – in other words at given productivity – machining the bainitic grade generates less efforts than the reference steel in the XY plan. Moreover the usable cutting conditions are more accessible for the bainitic steel grade. From the industrial point of view it leads to more flexibility in the choice of the cutting conditions and therefore less restrictive requirements in the power of the machines employed.

These results have to be compared and validated with the tool wear tests and the chips observations in order to establish a truthful machinability classification.

4.2 Evolution of the forces function of the cutting conditions

The values of k_C are computed from the measurement of M_z recorded during the drilling tests. A specific cutting pressure related with the thrust force F_z can also be computed by the same way. For this purpose, the evolution of the effort F_z is studied (Figure 10).

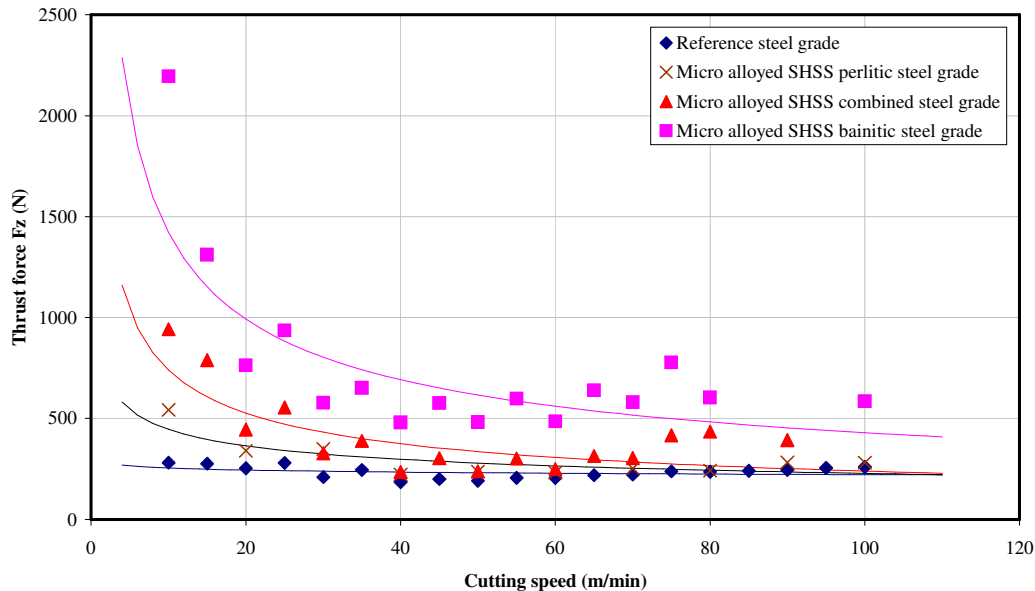

Figure 10 : Evolution of the thrust force F_z

The standard deviations – not represented for the legibility of the graphs – are about ± 15 N. The thrust force values are very closed one to the others excepted for the bainitic grade. The differences are minimal at about 40 m/min, which is around the $V_{c_{min}}$ values. The variations of thrust between the grades are coherent with their hardness. The thrust force tends to decrease when cutting speed belongs to the range $[0; V_{c_{min}}]$ and then is quite constant on $[V_{c_{min}}; 100 \text{ m/min}]$.

Concerning with the evolution of F_z with the feed (Figure 11), the differences between the steels are important at low feed (under f_{min}). These differences disappear at 0.07 mm/rev. According to the Couple Outil-Matière approach, the cutting speed chosen should be a little greater than $V_{c_{min}}$ for each grade. This is done to insure that the holes are drilled within conditions corresponding to the same thermo-mechanical mechanisms during the operation.

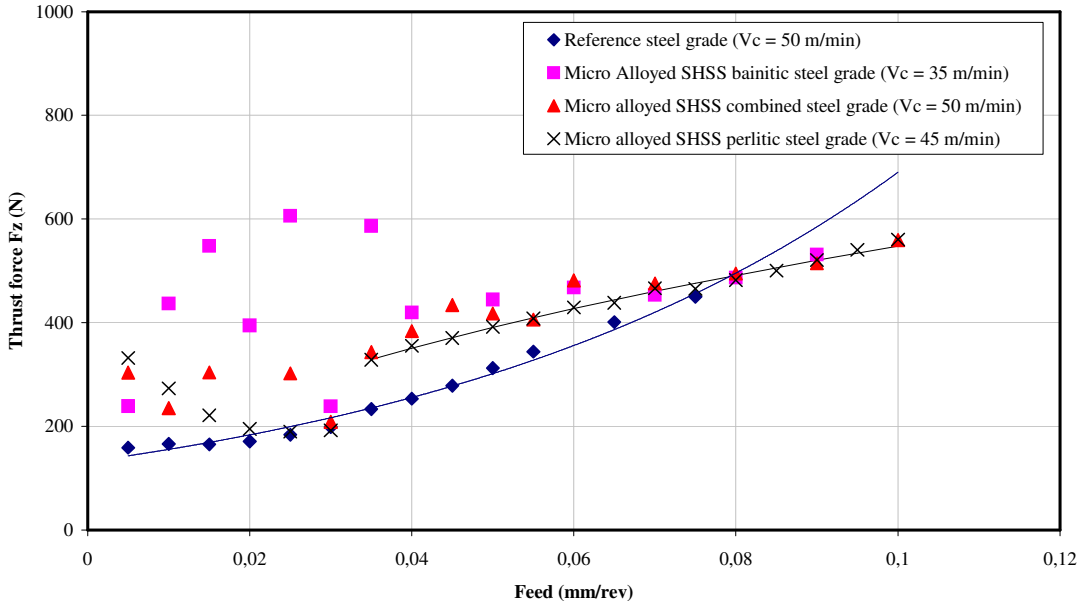

Figure 11 : Evolution of the thrust force F_z

The lower thrust forces are measured around 0.03 mm/rev which is the f_{min} value for these grades. As in the evolution of F_z within the cutting speed, F_z tends to decrease until f_{min} is reached. Then it linearly increases until 0.1 mm/rev.

4.3 Results of the tool wear tests

The analysis in tool wear is based on the Taylor equation (equation (3)). The value L_g is the length drilled when the tool wear reaches a stop criterion. Photos have been taken along the tool life and VB has been measured at each time. The tool wear criterion is $VB = 0.2$ mm. A new drill is employed for each step of the tests (4 drills were used for each steel). The following tables synthesize the photos obtained when the tool life criterion is reached (example on comparable cutting conditions).

Grades	Vc m/min	f mm/rev	Lg m	Relief face at length Lg
New drill				
Reference steel grade	50	0,06	3,6	
Micro Perlitic	50	0,06	1,5	



	Combined	50	0,06	0,7	
	Bainitic	55	0,05	0,7	

Table 2: Micrographics of the tool wear

From that analysis, the Taylor coefficients are computed:

	Reference grade	Micro Alloyed SHSS		
		Perlitic	Combined	Bainitic
N	0.444	0.246	0.190	0.448
X	0.347	0.081	0.450	0.312
C	32.874	38.654	12.272	17.941

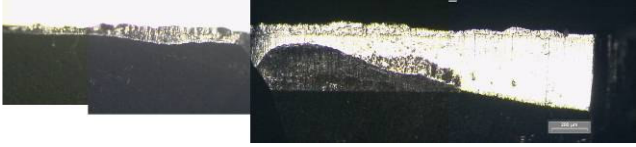
Table 3 : Taylor coefficients

Using these coefficients, the drillable length may be predicted. For instance, a feed of 0.04 mm/rev and a cutting speed of 40 m/min may cause a tool life about 8 meters on the reference steel, 2.5 m on the perlitic, 4.1 on the combined and 1.6 on the bainitic steel grade.

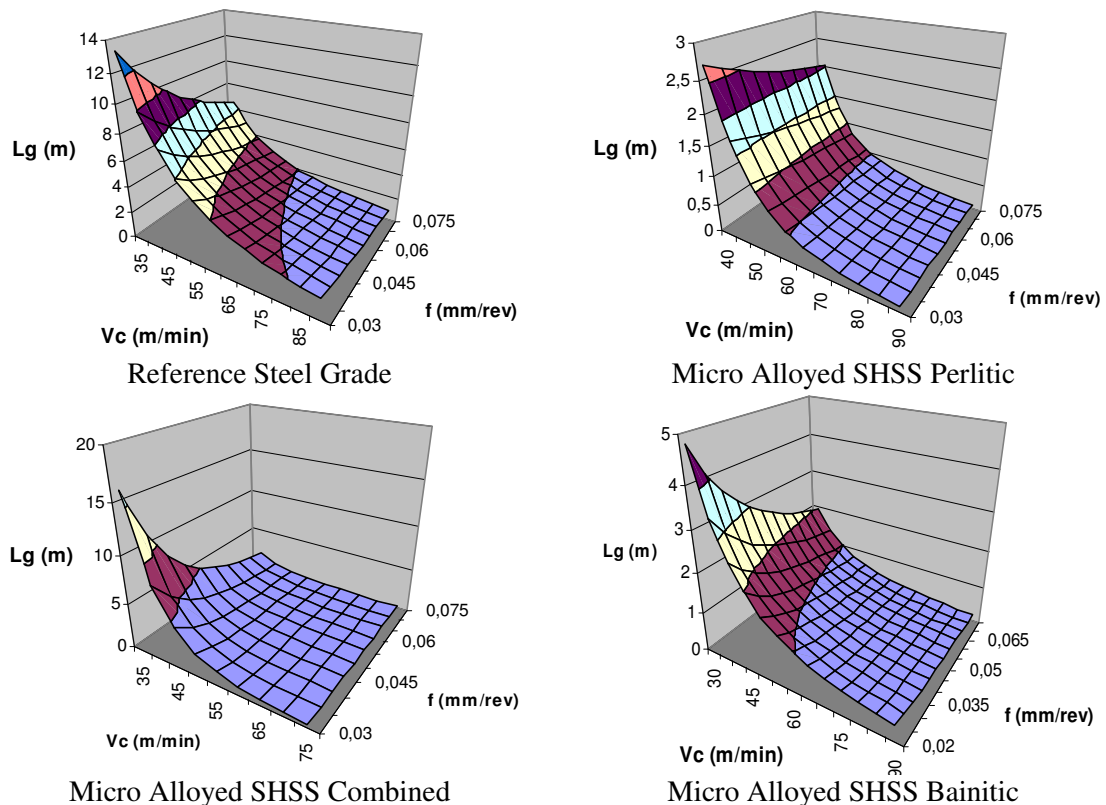

Figure 12 : Depth drillable with the different studied grades

The graphs (Figure 12) show that the drillable length depends on the cutting conditions. These graphs enable to choose quickly the cutting conditions leading to a particular tool life. Consequently, these graphs help also to know the frequency of tool change imposed by the cutting conditions chosen.

The tool wear tests have also enlightened the evolution of the power consumed during the tool life. Globally, the power increases slowly during the progressive wear stage and then increases brutally when approaching tool death (Figure 13).

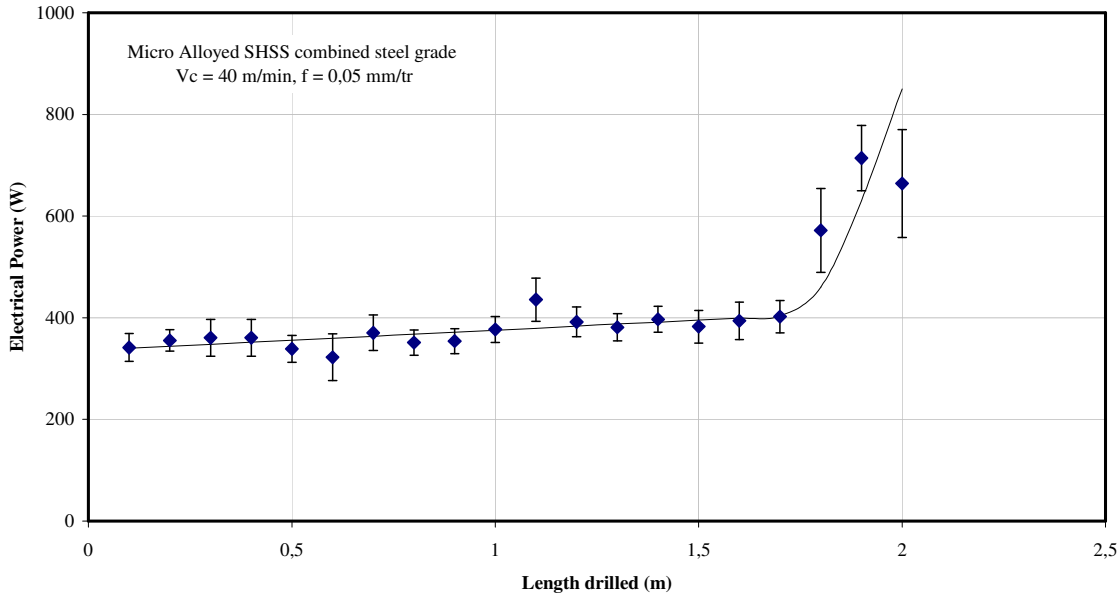

Figure 13 : Power required for the drilling operation in the combined grade along the tool life

4.4 Chip morphology analysis

To complete the information collected during the drilling, chips are collected and observed for each pair (V_c , f) investigated. The chips morphology - this term includes their length, shape, colour, roughness...- is standardized (NF E-66-505). Chips are required to be short (fragmented) to be properly ejected during the drilling operation. The shots are taken with the same skill: the width of each is 7 mm.

4.4.1 Reference steel

Photos of the chip			Photos of the chip			Photos of the chip		
V_c (m/min)	f (mm/rev)	Standard	V_c (m/min)	f (mm/rev)	Standard	V_c (m/min)	f (mm/rev)	Standard
10 to 15	0.03	6.2	20 to 55	0.03	6.1	60 to 100	0.03	6.1
50	0.005 to 0.01	4.3	50	0.05 to 0.075	5.2	50	0.045	1.3
						50	0.05 to 0.075	5.2

Table 4 : Chips morphologies of the reference steel

This analysis confirms the choice of $V_{c_{min}} = 45 \text{ m/min}$. Under 15m/min, the chips are conical and fragmented. This very low cutting speed value is not relevant because of the high cutting force levels

and, above all, the poor productivity. At high cutting speed (greater than 80 m/min), chips are getting too long. At low feed, the chips tend to be long and curled. At high feed, the chips are getting long and flat, a feed about 0.045 mm/rev seems to be the highest value allowing correct chips to be formed.

4.4.2 The Micro Alloyed SHSS Perlitic steel grade

Photos of the chip			Photos of the chip			Photos of the chip					
Vc (m/min)	f (mm/rev)	Standard	Vc (m/min)	f (mm/rev)	Standard	Vc (m/min)	f (mm/rev)	Standard			
10 to 15	0.03	6.2	20 to 50	0.03	6.2	55 to 100	0.03	6.1			
35	0.005 to 0.01	4.3	35	0.05 to 0.075	5.2	35	0.045	1.3	35	0.05 to 0.075	5.2

Table 5 : Chips morphologies of the Micro Alloyed SHSS Perlitic grade

In this case, the chips are short. Even if they seem long at high cutting speed (over 55 m/min), they are thin enough. The evolution with the feed is similar as before: huddled up at low feed, long and conical at high feed.

4.4.3 The Micro Alloyed SHSS Combined steel grade

Photos of the chip			Photos of the chip			Photos of the chip					
Vc (m/min)	f (mm/rev)	Standard	Vc (m/min)	f (mm/rev)	Standard	Vc (m/min)	f (mm/rev)	Standard			
10 to 15	0.03	6.2	20 to 50	0.03	2.2	55 to 100	0.03	6.2			
50	0.005 to 0.01	4.3	50	> 0.055	5.2	50	0.035 to 0.045	7	50	> 0.055	5.2

Table 6 : Chips morphologies of the Micro Alloyed SHSS Combined grade

About the combined steel, the chips are thick at high cutting speeds. On the range [20; 50 m/min] the chips are gathering dangerously and become unacceptable upon 50 m/min.

Concerned with the feed, the chips are crumpled but small under 0.03 mm/rev. Over 0.04 mm/rev the chips are thick and they are conical over 0.055 mm/rev.

4.4.4 The Micro Alloyed SHSS Bainitic steel grade





Photos of the chip			Photos of the chip			Photos of the chip		
Vc (m/min)	f (mm/rev)	Standard	Vc (m/min)	f (mm/rev)	Standard	Vc (m/min)	f (mm/rev)	Standard
								
10 to 15	0.03	8	60	0.03	8	> 60	0.03	6.2
								
35	0.005 to 0.01	4.3	35	0.015 to 0.08	8	35	0.09	7

Table 7 : Chips morphologies of the Micro Alloyed SHSS Bainitic steel grade

For this steel, the chips look like needles. Their size is growing a little with the cutting conditions. The needle shape is the extreme morphology of a conical shape.

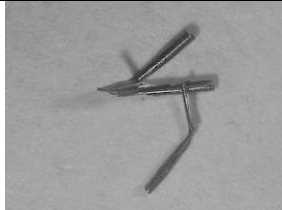
These photos confirm the homogeneity of the morphology of the bainitic steel chips. A similar shape of the chips on the whole operation range is to be related with the idea of flexibility in the cutting conditions since the supposition can be made that the thermo-mechanical mechanisms encountered are homogeneous.

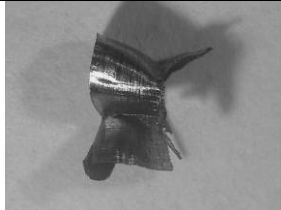
As a conclusion on these chips morphology analysis, the chosen values of $V_{c_{min}}$ and f_{min} are confirmed and we can observe on some grades the maximal cutting conditions. However, these chips are grey and therefore they don't show a warming of the tool. The more the steel is hard the more the chips are small. This leads to a compromise: the difficulties encountered when machining the hard steels are limited by the easiness of the chip to evacuate.

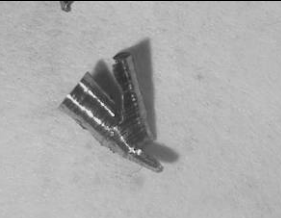
5 CONCLUSIONS

This paper has shown how to apply the entire COM approach to deep hole drilling operations by mean of the measurement of the forces, the tool wear and the chip morphology. The steels traceability has permit to characterize the different steels at each step of the process from the cast to the chip. The new steel elaborated by MITTAL Steel Europe R & D doesn't need a specific thermal treatment operation.

Experimental results show that bainite has a good behaviour in machining since its machining conditions can be chosen in a wide range. The reference steel presents the smaller range in machining.

Concerning the tool wear tests, the combined grade is the one which wears the tool the less. Bainitic and Perlitic steels are the most wearers grades. The generated chip forms confirm the choices of $V_{c_{min}}$ and f_{min} in deep hole drilling. The morphologies engendered by the 3 softer are quite similar, presenting long conical chips at high cutting conditions. The harder (Bainite) generates needle chips.

The chips analysis made it possible to determine maximal cutting conditions for some of the steel grades.

The observation of KT has been done but the first criterion reached in our test was $VB = 0.2$ mm. Deviation measurements have been carried out in the holes. The measures are included in the expected tolerances. The optimal steel to be forged in the crankshaft has to be chosen according to the compromise between tool wear, holes quality, productivity and drilling forces has to be taken into account for this choice. The forging ability has also to be considered.

Over the different tests, it is therefore undeniable that the behaviour of the new steel corresponds more to deep hole drilling than the reference steel. Since the crankshaft structure is heterogenic (the 3 structures are present) the tests performed here do have to be validated on the crankshaft.

6 ACKNOWLEDGMENT

The work described in the present paper was performed in the Laboratoire de Génie Industriel et de Production Mécanique (LGIPM) at CER ENSAM Metz, in partnership with MITTAL Steel Europe R & D also supported by Thyssen Krupp Mavilor, Botek and Shell Metalworking. The authors wish to thank all those who have contributed to the success of the project.

7 REFERENCES

- [AFNOR, 2000] AFNOR, "Domaine de fonctionnement des outils coupants - Couple outil-matière - Part 7 : Application à la technologie de perçage dans le plein - Part 8 : Mode d'obtention du couple outil-matière en perçage dans le plein", NF E 66-520-7, NF E 66-520-8, November 2000.
- [Astakhov, 1995] V.P. ASTAKHOV, V.V. GALITSKY, M.O.M. OSMAN, A novel approach to the design of self-piloting drills - Part 1 : geometry of the cutting tip and grinding process, ASME Journal of Engineering for Industry, Vol. 117, 1995, pp. 453-463.
- [Astakhov, 2002] V.P. ASTAKHOV – The mechanisms of bell mouth formation in gun drilling when the drill rotates and the workpiece is stationary, International Journal of Machine Tools and Manufacture, Vol. 42, 2002, pp.1135-1152.
- [Bagur, 1999] F. BAGUR – Matériaux pour Outils de coupe, Tech. de l'Ing., BM 7080, 1999.
- [Bomont et Al., 2004] O. BOMONT, A. D'ACUNTO, K. INAL, A. BOMONT, M. CONFENTE. "Comparison of steel grades for forged and machined parts: Determination of residual stresses", 7th CIRP International Workshop on Modelling of Machining Operations, May 2004, pp. 343-350.
- [Bomont et Al., 2004(2)] O. BOMONT, M. CONFENTE, L. MAROT, A. BOMONT, A. D'ACUNTO. "Comparison of steel grades for forged and machined parts: Methodology and testing", 5th Int. Conf. on Integrated Design and Manufacturing in Mechanical Engineering, 2004, pp. 34-41.
- [Gao et Al., 2000] C. H. GAO, K. CHENG, D. KIRKWOOD, "The investigation on the machining process of BTA deep hole drilling", Journal of Materials Processing Technology, Vol. 107, 2000, pp. 222-227.
- [Le Maître et Al., 1999] F. LE MAITRE, J.-C. HAMANN, C. TROMBERT. "Usinabilité et mécanismes endommageant des outils de coupe, Approches industrielle et fondamentale", Matériaux et Techniques N°5-6, 1999 pp. 5-14.
- [Lin et Al., 1995] S.C. LIN, C.J. TING, "Tool wear monitoring in drilling using force signals", Wear, Volume 180, 1995, pp. 53-60.
- [Poulachon, 2004] G. POULACHON. "Usinabilité des matériaux difficiles", Techniques de l'Ingénieur, BM 7048, 2004.
- [Resiak et Al., 2005] B. RESIAK, M.T. PERROT-SIMONETTA, M. CONFENTE, O. BOMONT, E. SCHNEIDER. "Aciers bas carbone bainitiques microalliés au niobium pour pièces à hautes caractéristiques mécaniques", 33ème Congrès de Traitement Thermique et de l'Ingénierie des Surfaces, Reims, 15-17 juin 2005, pp. 37-48.
- [Richardson et Al., 2000] R. RICHARDSON, R. BHATTI, "Review of research into the role of guide pads in BTA deep hole machining", Journal of Processing Technology, Vol. 110, 2001, pp. 61-69.
- [Sandvik, 2001] Société SANDVIK-COROMANT – Perçage, Tech. de l'Ing., BM 7088, 2001.

[Tönshoff et Al., 1994] H.K. TÖNSHOFF, W. SPINTIG, W. KÖNIG, A. NEISES, Machining of holes – Developments in drilling technology, CIRP Annals, 43/2, p. 551, 1994.

[Vigneau, 1999] J. VIGNEAU, Usinage des Matériaux Aéronautiques à faible Usinabilité, Techniques de l'Ingénieur, BM 7285, 1999.

[Weinert et Al., 2005] K. WEINERT, O. WEBBER, C. PETERS, "On the Influence of Drilling Depth Dependent Modal Damping on Chatter Vibration in BTA Deep Hole Drilling", CIRP Annals, Vol. 54/1/2005, 2005, p. 363-367.

[Zhang et Al., 2003] W. ZHANG, F. HE, D. XIONG, "Gundrill life improvement for deep-hole drilling on manganese steel", International Journal of Machine Tools and Manufacture, Vol. 44, 2004, pp. 327-331.