

Contents lists available at [ScienceDirect](http://ScienceDirect.com)

## International Journal of Infectious Diseases

journal homepage: [www.elsevier.com/locate/ijid](http://www.elsevier.com/locate/ijid)

## Review

The risk of global epidemic replacement with drug-resistant *Mycobacterium tuberculosis* strainsEmma S. McBryde<sup>a,\*</sup>, Michael T. Meehan<sup>a</sup>, Tan N. Doan<sup>a,b</sup>, Romain Ragonnet<sup>b,c</sup>, Ben J. Marais<sup>d</sup>, Vanina Guernier<sup>a</sup>, James M. Trauer<sup>e,f</sup><sup>a</sup> Australian Institute of Tropical Health and Medicine, James Cook University, 1 James Cook Drive, Townsville, QLD 4811, Australia<sup>b</sup> Department of Medicine, Royal Melbourne Hospital, University of Melbourne, Melbourne, Victoria, Australia<sup>c</sup> Centre for Population Health, the Burnet Institute, Melbourne, Victoria, Australia<sup>d</sup> The Children's Hospital at Westmead and the Marie Bashir Institute for Infectious Diseases and Biosecurity (MBI), University of Sydney, Sydney, New South Wales, Australia<sup>e</sup> School of Public Health and Preventive Medicine, Monash University, Melbourne, Victoria, Australia<sup>f</sup> Victorian Tuberculosis Program at the Peter Doherty Institute for Infection and Immunity, Melbourne, Victoria, Australia

## ARTICLE INFO

## Article history:

Received 5 October 2016

Accepted 24 January 2017

Corresponding Editor: Eskild Petersen, Aarhus, Denmark

## Keywords:

Antibiotic resistance

Mathematical modelling

Communicable disease control

Tuberculosis

## SUMMARY

**Objectives:** Multidrug-resistant tuberculosis (MDR-TB) is a threat to tuberculosis (TB) control. To guide TB control, it is essential to understand the extent to which and the circumstances in which MDR-TB will replace drug-susceptible TB (DS-TB) as the dominant phenotype. The issue was examined by assessing evidence from genomics, pharmacokinetics, and epidemiology studies. This evidence was then synthesized into a mathematical model.

**Methods:** This model considers two TB strains, one with and one without an MDR phenotype. It was considered that intrinsic transmissibility may be different between the two strains, as may the control response including the detection, treatment failure, and default rates. The outcomes were explored in terms of the incidence of MDR-TB and time until MDR-TB surpasses DS-TB as the dominant strain.

**Results and conclusions:** The ability of MDR-TB to dominate DS-TB was highly sensitive to the relative transmissibility of the resistant strain; however, MDR-TB could dominate even when its transmissibility was modestly reduced (to between 50% and 100% as transmissible as the DS-TB strain). This model suggests that it may take decades or more for strain replacement to occur. It was also found that while the amplification of resistance is the early cause of MDR-TB, this will rapidly give way to person-to-person transmission.

© 2017 The Author(s). Published by Elsevier Ltd on behalf of International Society for Infectious Diseases. This is an open access article under the CC BY-NC-ND license (<http://creativecommons.org/licenses/by-nc-nd/4.0/>).

## Contents

Introduction	15
Genomics	15
Pharmacokinetic variability	15
Epidemiology	15
Modelling drivers of MDR-TB burden	16
Conclusions	18
Funding	18
Conflict of interest	18
References	20

\* Corresponding author. Tel.: +61 7 478 16547.

E-mail address: [emma.mcbryde@jcu.edu.au](mailto:emma.mcbryde@jcu.edu.au) (E.S. McBryde).

## Introduction

*Mycobacterium tuberculosis* is now the most lethal infectious pathogen. In 2014, it caused 9.6 million cases of tuberculosis (TB) and killed 1.5 million people worldwide.<sup>1</sup> An alarming proportion of these cases can be attributed to drug-resistant strains of *M. tuberculosis*, which present an ever-growing threat to global TB control.

The serial introduction of single anti-mycobacterial agents in the 1940s (streptomycin),<sup>2</sup> 1950s (isoniazid),<sup>3</sup> and 1960s (rifampicin)<sup>4</sup> saw the emergence of drug-resistant isolates, particularly when these agents were used alone or intermittently.<sup>5,6</sup> Between 1970 and 1990, there were numerous outbreaks of drug-resistant TB involving strains resistant to two or more drugs.<sup>7</sup> This phenomenon necessitated the use of multidrug combination therapies, with strong health programmes – the directly observed treatment short-course (DOTS) strategy. DOTS, as it was originally implemented, focused on drug-susceptible (DS) TB. Its aim was to increase successful treatment outcomes and reduce drug resistance by ensuring all TB patients were treated with multiple agents for at least 6 months.

Despite these measures, since 1985, the world has seen a constant rise in the levels of multidrug-resistant (MDR) TB, defined as *M. tuberculosis* with in vitro resistance to at least isoniazid and rifampicin, the two most potent first-line anti-TB drugs. The most recent report suggests that these isolates accounted for at least 480 000 incident cases and 210 000 deaths worldwide in 2014.<sup>1</sup> Extensively drug-resistant (XDR) strains, which are MDR-TB strains with additional resistance to fluoroquinolones and a second-line injectable agent (kanamycin, amikacin, or capreomycin), have now been found in every region of the world.<sup>1</sup>

Initially, public health agencies looked at the soundness of the DS-TB control programmes as a means to fix the problem: “While it is important, on a clinical basis and epidemiologically in some contexts, to care optimally for patients with MDR-TB, it is more important to address the cause of MDR-TB and to fix the programme generating MDR-TB”.<sup>8</sup> However, a new paradigm has gradually emerged in MDR-TB control, with greater acknowledgement that MDR-TB must be addressed directly. This paper examines why this shift in thinking is necessary to control MDR-TB, as well as the consequences of neglecting to address the problem of MDR-TB directly. Evidence from genomics, pharmacokinetics (PK), and epidemiology was reviewed. Mathematical modelling was then used to synthesize the evidence into scenarios in which MDR-TB and DS-TB vie for dominance.

## Genomics

In the last decades, major advances in molecular biology have increased our knowledge of the mechanisms of resistance to the main anti-TB drugs, with the identification of specific gene mutations that are associated with drug resistance.<sup>9</sup> This has also allowed the detailed mapping of *M. tuberculosis* transmission pathways, which has indicated typical epidemic spread of drug-resistant strains of *M. tuberculosis* in most settings where this has been evaluated.<sup>10</sup>

Unlike other bacteria, in which acquired drug resistance is generally mediated through horizontal transfer of mobile genetic elements, *M. tuberculosis* acquires drug resistance through spontaneous chromosomal mutation, typically resulting in a fitness cost seen as a reduced growth rate in vitro.<sup>11</sup> However, this fitness cost varies depending on the specific drug resistance-conferring mutations, and mutations associated with no fitness cost have also been described.<sup>12–14</sup> Indeed, other processes, such as compensatory evolution and genetic co-selection, complicate the picture. As an example, the genetic background of each strain in

which a specific resistance-conferring mutation occurs can modulate the fitness impact of this mutation, such interaction between genes being called epistasis.<sup>12</sup>

Resistance to rifampicin is the most pressing concern in TB management, because it necessitates very long, expensive and relatively toxic drug schedules and leads to poorer outcomes. The identification of specific compensatory mutations among clinical strains of *M. tuberculosis* has improved our understanding of drug resistance and fitness.<sup>15–17</sup> Rifampicin resistance is nearly always caused by one of several possible point mutations to the *rpoB* gene, which encodes a small part of the  $\beta$ -subunit of RNA polymerase close to the catalytic centre of the enzyme.<sup>9,18,19</sup> The so-called rifampicin resistance-determining region (RRDR) covers 81 base pairs encoding amino acids 507–533 in the  $\beta$ -subunit. Compensatory mutations that ameliorate the fitness costs of the common rifampicin-resistance mutation *rpoB* R529C have been described in the *rpoA*, *rpoB*, and *rpoC* genes, coding for different subunits of RNA polymerase ( $\alpha$ ,  $\beta$ - and  $\beta'$  subunits, respectively). Some clinical rifampicin-resistant *M. tuberculosis* isolates have mutations outside the detection regions (leading to false-negative *rpoB* tests), while other isolates reveal no *rpoB* mutation at all. Two efflux pumps (Rv2936 and Rv0783) over-expressed in the resistant isolates are postulated to cause the rifampicin resistance phenotype in these *M. tuberculosis* strains.<sup>20</sup>

## Pharmacokinetic variability

Drug resistance in *M. tuberculosis* is now recognized to result from complex drivers, rather than simply from weak programmes and inadequate adherence to therapy. Recent evidence suggests that the emergence of drug resistance can occur despite better than 98% treatment completion.<sup>21</sup> There is increasing evidence that variability in PK profiles between individuals (i.e., inter-individual variability) is a more likely cause of the emergence of drug resistance than non-completion of treatment.<sup>22,23</sup> Previous studies have shown that the PK of first-line anti-TB drugs including isoniazid,<sup>24</sup> pyrazinamide,<sup>25</sup> rifampicin,<sup>26</sup> and ethambutol<sup>27</sup> exhibit marked inter-individual variability. Such variability in PK occurs as a result of demographic characteristics such as sex, age, ethnicity, and body weight, comorbidities, drug interactions, and genetic polymorphisms affecting drug absorption, metabolism, and elimination. PK variability in turn may lead to inadequate drug exposure at the site of infection, facilitating the emergence of drug resistance.<sup>21,22</sup> For example, Calver et al. found in their clinical study that low drug exposure (as measured by area under the concentration–time curve (AUC) and peak concentrations ( $C_{max}$ )) was the main driver of drug resistance despite meticulous DOTS.<sup>21</sup> Similarly, Srivastava et al. predicted that 1% of patients with perfect adherence would develop MDR-TB due to suboptimal drug exposure as a manifestation of PK variability alone.<sup>22</sup>

## Epidemiology

MDR-TB has emerged independently in many parts of the globe, with early discovery in South Africa and a rapid rise in Eastern Europe with the collapse of Soviet public health systems.<sup>28</sup> MDR-TB is now found in most countries around the world and the proportion of new TB cases showing multidrug resistance is increasing. Currently, the highest absolute numbers of MDR-TB cases occur in the most populous countries: India and China.<sup>1</sup> In contrast, the highest proportions of isolates showing drug resistance are found in Eastern Europe, with 32% and 76% of new and previously treated cases, respectively, found to be MDR-TB in Belarus.<sup>29</sup> However, the true global incidence of MDR-TB is unknown, the proportion of new cases tested for drug susceptibility is only 12% globally,<sup>1</sup> and MDR-TB is spreading in countries with

the poorest surveillance systems; for example, the incidence of MDR-TB may be as high as 1000 per 100 000 population in Daru, Papua New Guinea.<sup>30</sup>

On the basis of early evidence of the variable and slow emergence of multidrug resistance decades after the introduction of therapy, many argued that MDR-TB would not replace DS-TB.<sup>31</sup> However, epidemiology studies now provide evidence to the contrary. For example, studies have shown that the transmission of drug-resistant strains (i.e., primary resistance) rather than amplification from susceptible strains (acquisition of resistance-conferring mutations, i.e., acquired resistance) is the dominant source of MDR-TB.<sup>32</sup> Children are an indicator of strains being transmitted within communities; a recent study in China showed that children presenting with their first episode of TB frequently had MDR *M. tuberculosis*.<sup>33</sup>

Drug-resistant *M. tuberculosis* strains have several survival advantages owing to the way in which TB is managed globally. Firstly, because only a fraction of new cases in the world are tested for resistance,<sup>1</sup> MDR-TB has the opportunity to spread in the community before detection. Universal use of GeneXpert for new cases is being advocated to improve the detection of resistant cases and hence inhibit their spread. Additionally in many countries MDR-TB treatment has a large backlog of patients, delaying specific therapy.<sup>34</sup> Finally after treatment has begun, the treatment regimen is toxic, slower to reduce the bacterial burden,<sup>35</sup> and less successful, leading to treatment failures and withdrawals, giving further opportunity for MDR-TB to spread.<sup>36</sup> For this reason, it is possible to speculate (and this will be shown with mathematical modelling) that all else being equal, MDR-TB is likely to take over from DS-TB.

It is now possible to estimate the likely contribution of the various pathways to MDR-TB, i.e. (1) primary transmission of MDR-TB resulting in new or retreatment cases, or (2) the development of drug resistance in patients infected with DS-TB following inadequate drug exposure. Global MDR-TB rates and available modelling data suggest that the primary transmission of MDR-TB strains from person to person has become more frequent than acquisition following treatment.<sup>32</sup>

If MDR-TB were not transmissible, its emergence would pose at worst a small increased cost for health systems. MDR-TB transmissibility, the relative likelihood of person-to-person

transmission, is an important determinant of whether it will come to dominate over DS-TB. The early hypothesis that resistance is always associated with a loss of bacterial fitness, and hence leads to lower case fatality rates and decreased transmission of such strains, has been disproved.<sup>6</sup> Indeed, some isolates of MDR *M. tuberculosis* appear to have no reduction in fitness.

Observations and simple calculations show that most MDR-TB is transmitted rather than mutated from pre-existing DS strains. Figure 1 gives a simplified summary of the sources of MDR-TB found in new and pre-treated cases. Much is often made of the high ratio of MDR-TB isolates in retreated cases (global estimate >20%) compared with new cases (global estimate 3.3%) of TB.<sup>1</sup> However the ratio does not necessarily indicate high rates of amplification, as illustrated in Figure 1.

These arguments combined provide a framework to consider MDR-TB as an infection that can arise whenever first-line agents are used against DS-TB. Although the amplification of resistance is made worse by poor programmes, even well-functioning programmes should expect some MDR-TB as a result of natural variability in population PK. Once MDR-TB has emerged, its potential to displace DS-TB as the dominant phenotype depends on features other than those that drive the original amplification. These may depend on the transmission rates in the community and the detection and cure rates of the TB programme. The following section uses mathematical models to explore these ideas and elicit the key drivers of MDR-TB dominance.

### Modelling drivers of MDR-TB burden

Despite the evidence presented above, there remains considerable debate as to the key drivers of the emerging drug-resistant TB epidemic. Mathematical modelling can illuminate this discussion by simulating the transmission dynamics in high-risk communities and identifying the primary factors that most strongly contribute to the incidence and prevalence of drug-resistant strains. In this section, the conditions under which one would expect MDR-TB to become dominant and the time taken to transition to the dominant type are examined.

For this purpose, the two-strain TB transmission model introduced by Trauer et al. was used.<sup>37</sup> The two-strain model allows for a modified transmissibility, and detection rate, of the MDR-TB strain

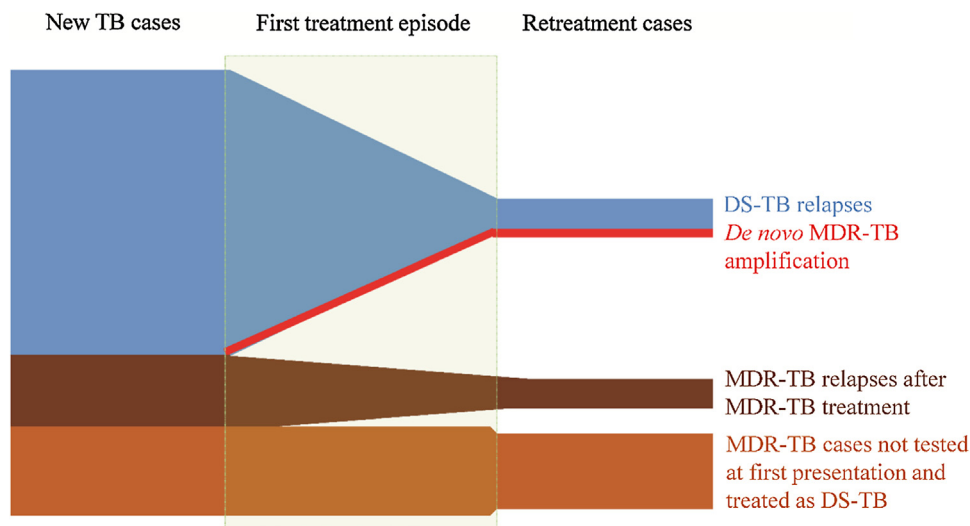

**Figure 1.** Diagram illustrating several mechanisms for a greater proportion of multidrug-resistant tuberculosis (MDR-TB) in retreatment cases (right) by comparison to new cases (left), highlighting that resistance amplification through treatment non-completion is not the only cause of the discrepancy (red pathway). Other explanations include: (1) lower rates of treatment success for appropriately treated MDR-TB patients by comparison to drug-susceptible tuberculosis (DS-TB), such that more retreatment episodes will be MDR-TB (brown pathway); (2) lower rates of testing for drug resistance at first presentation, such that many patients with transmitted MDR-TB will not be recognized as such until re-presentation (orange pathway); and (3) a lower denominator, due to high treatment success rates at the first treatment episode.

relative to the transmissibility and detection rate of the DS-TB strain. Additionally, the model allows for different treatment failure rates according to the resistance profile. A diagram of the model, along with the ordinary differential equations and all parameter values used, is provided in the Appendix.

Baseline parameters for the model were chosen to simulate high prevalence conditions, in which TB is always endemic regardless of the values of the modifiable parameters. In doing this it was aimed to capture transmission dynamics seen in global hotspots;<sup>37</sup> however, the model was not specifically calibrated to a particular country. Hence the aim was to make general qualitative and semi-quantitative conclusions about model outcomes, rather than specific quantitative predictions.

An amplification pathway is included in the model structure, representing acquired resistance, so that as long as DS-TB exists and is treated, it will continue to supply MDR-TB patients. The resultant equilibrium scenarios are one of two possibilities: either both DS-TB and MDR-TB remain in circulation (this represents DS being the dominant driver of TB transmission), or MDR-TB outcompetes DS-TB, driving the latter to extinction.

The results, displayed in Figure 2, show the incidence of MDR-TB and time to replacement of DS-TB with MDR-TB as a function of the relative transmissibility and relative detection rate of MDR-TB compared with DS-TB (time of replacement is defined as the point at which the incidence of MDR-TB exceeds the incidence of DS-TB). Predictably, the higher the transmissibility of the isolate (moving along the x-axis from zero to twice as fit as DS-TB), the higher the incidence of MDR-TB at equilibrium and the faster its progress to replace DS-TB strains as the dominant strain population. In this model, the MDR-TB burden depends more sensitively on the relative strain transmissibility than it does on the relative detection rate. Figure 2 indicates a clear delineation, such that if the relative transmissibility of MDR-TB is more than approximately 80% of DS-TB, MDR-TB always comes to dominate, regardless of the relative detection rate. Conversely, if the relative transmissibility of MDR-TB is less than approximately 50%, DS-TB remains dominant regardless of the relative detection rate.

The relative detection rate does influence the incidence and dominance of MDR-TB in the interval in which MDR-TB transmits 50% to 80% as efficiently as DS-TB. A detection rate of MDR-TB equal to that of DS-TB (as may be expected when GeneXpert is the first-line

diagnostic), would lead to very low levels of MDR-TB, whereas no MDR-TB detection would lead to high incidence levels (Figure 2).

The equilibrium MDR-TB incidence and replacement time, respectively, as functions of the unsuccessful live outcome rate (i.e., default or failure) and the relative detection rates are shown in Figure 3. In these graphs the impact of changes in transmissibility (relative transmissibility is set at a fixed value of 70%) is not considered. The upper left-hand corner of each panel in Figure 3 – corresponding to the best case control scenario – finds DS-TB dominates; however, as we move towards the lower right-hand corner, MDR-TB begins to dominate. Surprisingly, in this case, the MDR-TB burden is more sensitive to the relative detection rate than it is to the treatment outcome. However, as the relative detection rate increases, the treatment outcome becomes more important. This calculation was repeated for a relative transmission fitness of 100% and it was found that MDR-TB dominates under all conditions, except zero treatment.

Laboratory findings suggest that compensatory mutations occur in some isolates of MDR *M. tuberculosis* that potentially allow the growth and transmissibility fitness cost to be minimized or completely overcome.<sup>38</sup> Furthermore, modelling suggests that strain replacement can occur even if the basic reproduction number of the MDR-TB strain is less than that of the DS strain; that is, even when there is a fitness cost to drug resistance.<sup>37</sup> Therefore, the growing risk of the MDR-TB epidemic cannot be dismissed by assuming that the relative fitness of the mutant strains is diminished, which in itself may not be a valid assumption.

The shortest time period for MDR-TB to overcome the less resistant co-circulating strain is of the order of decades. Given this, it would be possible to mistake the slow emergence of the resistant strain for an absence of significant burden at equilibrium. This may help to explain the historical assumption that MDR-TB was a temporary phenomenon resulting directly from non-completion of therapy in individual patients, rather than a persistent challenge to global control. Moreover, as the replacement time is of the order of centuries under most proposed conditions (Figures 2 and 3), this could also explain the observation that some countries have very low rates of MDR-TB while others have extremely high rates, at 50 years following introduction of the antibiotics.

In Figure 4, the model output of the proportion of MDR-TB that arises through transmission from person to person as a fraction of

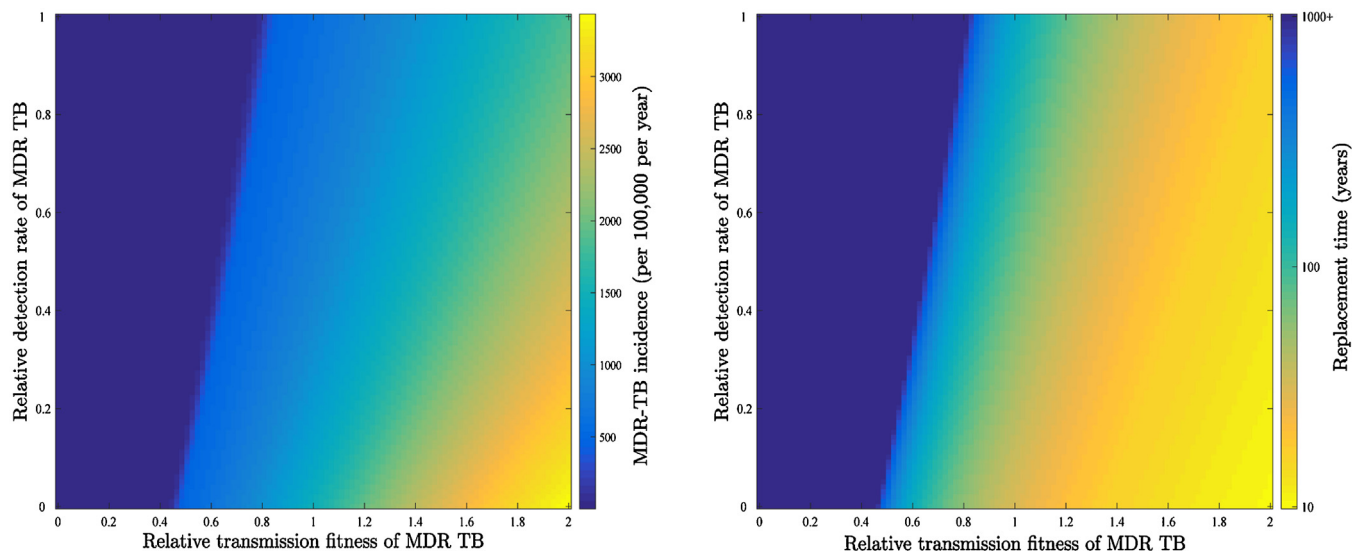

**Figure 2.** Left: Equilibrium multidrug-resistant tuberculosis (MDR-TB) incidence as a function of relative transmissibility and relative treatment detection rate. Right: Time taken for MDR-TB incidence to overtake drug-susceptible tuberculosis (DS-TB) incidence, as a function of the relative transmissibility and relative treatment detection rate. The simulations were terminated at 1000 years; hence the dark blue colour represents no replacement of DS-TB with MDR-TB.

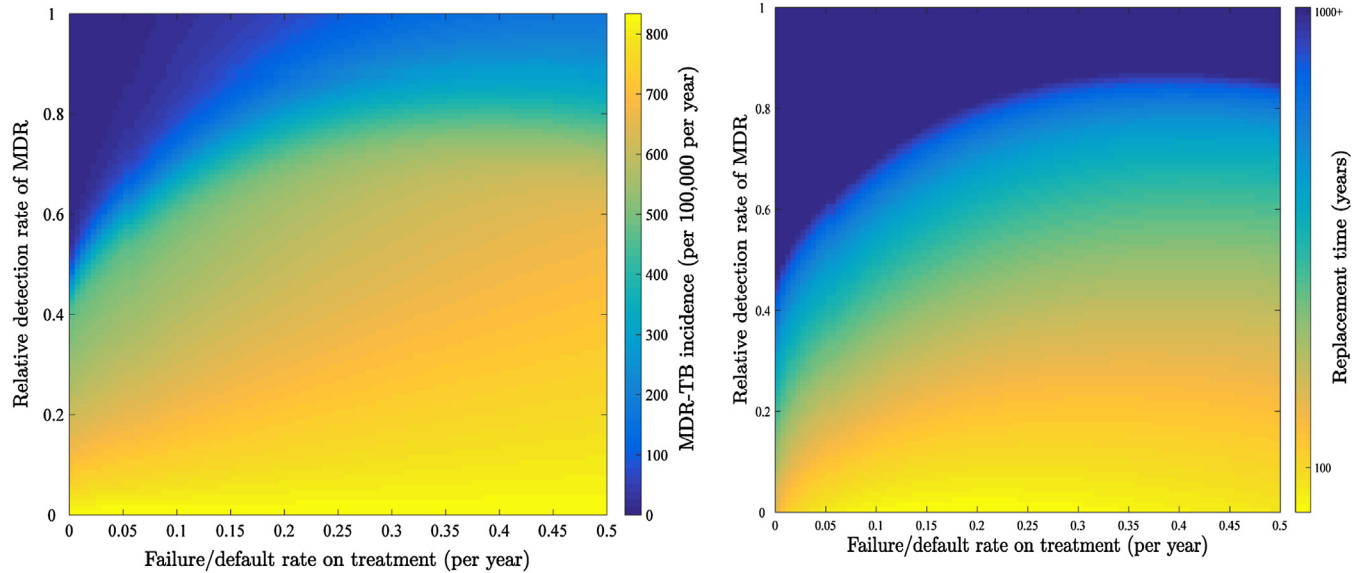

**Figure 3.** Left: Incidence of multidrug-resistant tuberculosis (MDR-TB) as a function of proportion default/failure rate as a fraction of all cases of active TB treated ( $x$ -axis) and relative detection rate of MDR-TB compared to drug-susceptible tuberculosis (DS-TB) ( $y$ -axis). Right: Time to replacement of DS-TB with MDR-TB as a function of the same variables. Replacement time is shown on a logarithmic scale. The simulations were terminated at 1000 years; hence the dark blue colour represents no replacement of DS-TB with MDR-TB.

all incident MDR-TB is measured. It can be seen that, initially, all MDR-TB arises through amplification, as would be expected, given that starting conditions are that there is no MDR-TB. After 10 years, the proportion of MDR-TB is nearing its equilibrium state and depends on the relative transmissibility of the MDR-TB.

In this model, the amplification of MDR-TB from DS-TB serves as a trigger, bringing MDR into existence, while fitness cost and the favourable conditions for replacement inadvertently brought about by control programmes determine whether MDR will dominate. Factors that drive MDR-TB replacement include low levels of detection of MDR compared with DS-TB and higher default/failure rates of MDR-TB than DS-TB. However, relative detection rates are much more influential than relative default/failure rates.

Earlier models, such as those of Dye and Espinal, had a similar structure but did not explore as broad a parameter space.<sup>39</sup> In fact, they did not allow that MDR-TB may be harder to detect than DS-

TB, or be more likely to fail therapy, effectively exploring only the top left corner of the heat maps in Figures 2 and 3. As can be seen, this is not a very interesting part of the parameter space and one in which the MDR-TB transmission environment is unfavourable.

Further modelling work defining the conditions under which strain replacement may occur will be very useful in determining the risk of additional or accumulated resistance, for example the emergence of XDR-TB and resistance to newer agents such as bedaquiline and delamanid.

## Conclusions

Modelling demonstrates that TB with a resistant phenotype may thrive even in the presence of some transmissibility fitness cost – a concerning possibility that needs to be appreciated by public health policymakers. Current surveillance and reporting systems are inadequate to estimate the extent of MDR-TB,<sup>40</sup> and the reporting requirements tend to obscure the magnitude of primary transmission of drug-resistant TB,<sup>41</sup> which is a critical methodological flaw that needs to be addressed urgently. Without a renewed focus on the prevention, early diagnosis, and effective treatment of MDR-TB cases, we are likely to witness MDR-TB epidemic replacement in the coming decades, which could derail progress towards global TB control and ultimate elimination.

## Funding

This research did not receive any specific grant from funding agencies in the public, commercial, or not-for-profit sectors.

## Conflict of interest

None.

## Appendix A.

### Figure A1.

Model used for the modelling section of this paper; derived from Trauer et al.<sup>37</sup>

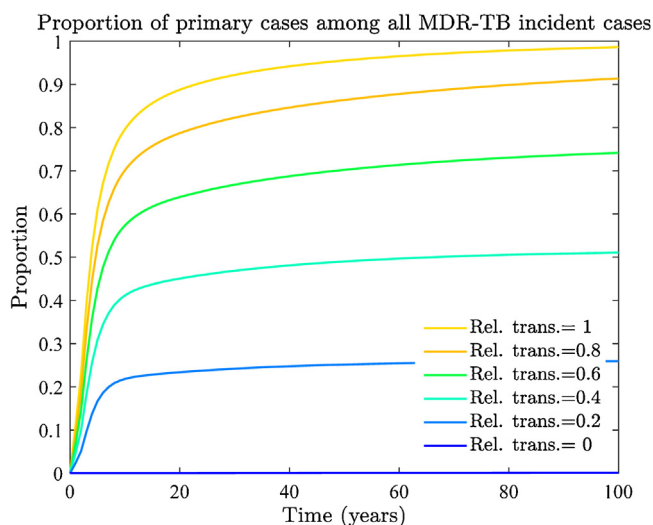

**Figure 4.** Ratio of multidrug-resistant (MDR) cases of tuberculosis (TB) that are transmitted versus acquired as a function of time ( $x$ -axis) and relative transmission (Rel. Trans.).

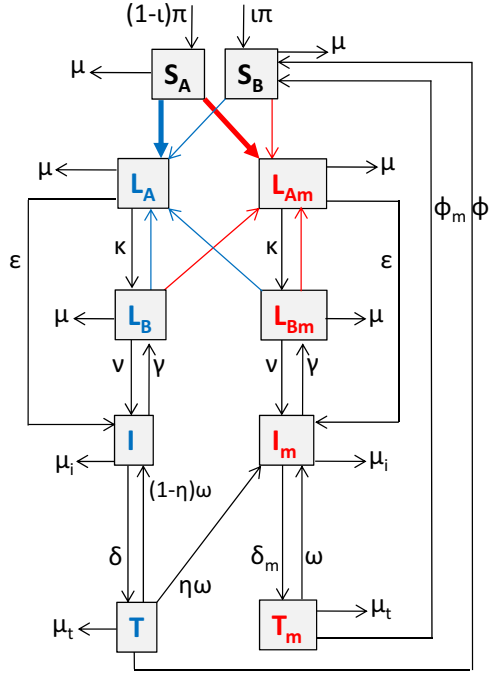

**Figure A1.** Model structure: red compartments with m subscripts=population infected with multidrug-resistant tuberculosis (MDR-TB); thick blue arrow= infection with drug-susceptible TB (DS-TB) in fully susceptible persons ( $\lambda$ ); thin blue arrows=infection with DS-TB in partially immune persons ( $\lambda_d$ ); thick red arrow=infection with MDR-TB in fully susceptible persons ( $\lambda_m$ ); thin red arrow=infection with MDR-TB in partially immune persons ( $\lambda_{dm}$ ). Susceptible compartments (S) are divided into fully susceptible (subscript A) and partially immune (subscript B), while latent compartments (L) are divided into early (subscript A) and late (subscript B) latency.

The system of ordinary differential equations governing the model is given by:

$$\frac{dS_A}{dt} = (1 - \iota)\pi N - (\lambda + \lambda_m + \mu)S_A$$

$$\frac{dS_B}{dt} = \iota\pi N + \varphi T + \varphi_m T_m - (\lambda_d + \lambda_{dm} + \mu)S_B$$

$$\frac{dL_A}{dt} = \lambda S_A + \lambda_d(S_B + L_B + L_{Bm}) - (\epsilon + \kappa + \mu)L_A$$

$$\frac{dL_{Am}}{dt} = \lambda_m S_A + \lambda_{dm}(S_B + L_B + L_{Bm}) - (\epsilon + \kappa + \mu)L_{Am}$$

$$\frac{dL_B}{dt} = \kappa L_A + \gamma I - (\lambda_d + \lambda_{dm} + \nu + \mu)L_B$$

$$\frac{dL_{Bm}}{dt} = \kappa L_{Am} + \gamma I_m - (\lambda_d + \lambda_{dm} + \nu + \mu)L_{Bm}$$

$$\frac{dI}{dt} = \epsilon L_A + \nu L_B + (1 - \eta)\omega T - (\gamma + \delta + \mu_i)I$$

$$\frac{dI_m}{dt} = \epsilon L_{Am} + \nu L_{Bm} + \eta\omega T + \omega T_m - (\gamma + \delta_m + \mu_i)I_m$$

$$\frac{dT}{dt} = \delta I - (\varphi + \omega + \mu_t)T$$

$$\frac{dT_m}{dt} = \delta_m I_m - (\varphi_m + \omega + \mu_t)T_m$$

Where:

$$\lambda = \beta\rho(I + oT)/N \quad \rightarrow$$

$$\lambda_d = \chi\beta\rho(I + oT)/N \quad \rightarrow$$

$$\lambda_m = \beta_m\rho(I_m + oT_m)/N \quad \rightarrow$$

$$\lambda_{dm} = \chi\beta_m\rho(I_m + oT_m)/N \quad \rightarrow$$

$$N = S_A + S_B + L_A + L_B + L_{Am} + L_{Bm} + I + I_m + T + T_m$$

The parameter values used in the model and Figures 2–4 are shown in Table A1 below.

**Table A1**  
Parameter values and their definitions.

Parameter	Meaning	Value
<b>Fixed disease parameters</b>		
$\epsilon$	Early progression	0.072
$\kappa$	Transition to late latency	0.9
$\nu$	Reactivation	0.004
$\gamma$	Spontaneous recovery	0.33
$\mu_i$	TB-specific death rate	0.15
$\mu_t$	Treated TB-specific death rate	$0.5 \times \mu_i$
$\eta$	Amplification	0.035
$o$	Treatment modification of infectiousness	0.21
$\chi$	Partial immunity	0.49
$\phi$	Drug-susceptible treatment rate	2
$\phi_m$	MDR-TB treatment rate	0.5
<b>Fixed epidemiological parameters</b>		
$\pi$	Birth rate	Varied to population-wide death rate
$\mu$	TB-free mortality	0.016
$\rho$	Infectious proportion	0.35
<b>Modifiable parameters (baseline values)</b>		
$\iota$	BCG vaccination rate	0.65
$\delta$	Detection rate	0.72
$\delta_m$	MDR-TB detection rate	0
$\omega$	Default rate	0.25
$\beta$	Effective contact rate	38 <sup>a</sup>
$\beta_m$	MDR-TB effective contact rate	0.7 $\beta$
<b>Parameters modified for Figure 2</b>		Range
$\delta_m$	MDR-TB detection rate	0 – $\delta$ (i.e. 0 – 0.72)
$\beta_m$	MDR-TB effective contact rate	0 – $2\beta$ (i.e. 0 – 76)
<b>Parameters modified for Figure 3</b>		Range
$\delta_m$	MDR-TB detection rate	0 – $\delta$ (i.e. 0 – 0.72)
$\omega$	Default rate	0 – $\phi$ (i.e. 0 – 0.5)
<b>Parameters modified for Figure 4</b>		Range
$\beta_m$	MDR-TB effective contact rate	0 – $\beta$ (i.e. 0 – 38)

TB, tuberculosis; MDR, multidrug-resistant; BCG, bacille Calmette–Guérin.

<sup>a</sup> Iteratively adjusted to match an incidence rate of 400 to 450 per 100 000 per year.

## References

- World Health Organization. *Global tuberculosis report 2015*. Geneva: WHO; 2015.
- Tempel CW, Dye WE. Selecting the streptomycin regimen for patients with pulmonary tuberculosis with special reference to the intermittent dosage schedule. *Dis Chest* 1949;**16**:704–13.
- Tuberculosis Chemotherapy Clinical Trials Committee. The treatment of pulmonary tuberculosis with isoniazid. *BMJ* 1952;**2**:735–46.
- Verbist L, Gyselen A. Antituberculous activity of rifampin in vitro and in vivo and the concentrations attained in human blood. *Am Rev Respir Dis* 1968;**98**:923–32.
- Dye WE, Lynch HP, Brees AG. Incidence of bacterial resistance encountered with tuberculosis chemotherapy regimens employing isoniazid alone and in combination with intermittent streptomycin. *Am Rev Tuberc* 1953;**67**:106–7.
- Fox W, Ellard GA, Mitchison DA. Studies on the treatment of tuberculosis undertaken by the British Medical Research Council tuberculosis units, 1946–1986, with relevant subsequent publications. *Int J Tuberc Lung Dis* 1999;**3**:S231–79.
- Villarino ME, Geiter LJ, Simone PM. The multidrug-resistant tuberculosis challenge to public health efforts to control tuberculosis. *Public Health Rep* 1992;**107**:616–25.
- Frieden TR, Driver CR. Tuberculosis control: past 10 years and future progress. *Tuberculosis (Edinb)* 2003;**83**:82–5.
- Ramaswamy S, Musser JM. Molecular genetic basis of antimicrobial agent resistance in *Mycobacterium tuberculosis*: 1998 update. *Tuber Lung Dis* 1998;**79**:3–29.
- Moss AR, Alland D, Telzak E, Hewlett Jr. D Jr., Sharp V, Chiliade P, et al. A city-wide outbreak of a multiple-drug-resistant strain of *Mycobacterium tuberculosis* in New York. *Int J Tuberc Lung Dis* 1997;**1**:115–21.
- Andersson DI, Hughes D. Antibiotic resistance and its cost: is it possible to reverse resistance? *Nat Rev Microbiol* 2010;**8**:260–71.
- Gagneux S, Long CD, Small PM, Van T, Schoolnik GK, Bohannon BJ. The competitive cost of antibiotic resistance in *Mycobacterium tuberculosis*. *Science* 2006;**312**:1944–6.
- Botzger EC, Springer B, Pletschette M, Sander P. Fitness of antibiotic-resistant microorganisms and compensatory mutations. *Nat Med* 1998;**4**:1343–4.
- Sander P, Springer B, Prammananan T, Sturmfels A, Kappler M, Pletschette M, et al. Fitness cost of chromosomal drug resistance-conferring mutations. *Antimicrob Agents Chemother* 2002;**46**:1204–11.
- Sherman DR, Mdluli K, Hickey MJ, Araín TM, Morris SL, Barry CE, et al. Compensatory *ahpC* gene expression in isoniazid-resistant *Mycobacterium tuberculosis*. *Science* 1996;**272**:1641–3.
- Comas I, Borrell S, Roetzer A, Rose G, Malla B, Kato-Maeda M, et al. Whole-genome sequencing of rifampicin-resistant *Mycobacterium tuberculosis* strains identifies compensatory mutations in RNA polymerase genes. *Nat Genet* 2012;**44**:106–10.
- Casali N, Nikolayevskyy V, Balabanova Y, Harris SR, Ignatyeva O, Kontsevaya I, et al. Evolution and transmission of drug-resistant tuberculosis in a Russian population. *Nat Genet* 2014;**46**:279–86.
- Campbell EA, Korzheva N, Mustaev A, Murakami K, Nair S, Goldfarb A, et al. Structural mechanism for rifampicin inhibition of bacterial RNA polymerase. *Cell* 2001;**104**:901–12.
- Heep M, Brandstatter B, Rieger U, Lehn N, Richter E, Rusch-Gerdes S, et al. Frequency of *rpoB* mutations inside and outside the cluster I region in rifampin-resistant clinical *Mycobacterium tuberculosis* isolates. *J Clin Microbiol* 2001;**39**:107–10.
- Pang Y, Lu J, Wang Y, Song Y, Wang S, Zhao Y. Study of the rifampin monoresistance mechanism in *Mycobacterium tuberculosis*. *Antimicrob Agents Chemother* 2013;**57**:893–900.
- Calver AD, Falmer AA, Murray M, Strauss OJ, Streicher EM, Hanekom M, et al. Emergence of increased resistance and extensively drug-resistant tuberculosis despite treatment adherence, South Africa. *Emerg Infect Dis* 2010;**16**:264–71.
- Srivastava S, Pasipanodya JG, Meek C, Leff R, Gumbo T. Multidrug-resistant tuberculosis not due to noncompliance but to between-patient pharmacokinetic variability. *J Infect Dis* 2011;**204**:1951–9.
- Pasipanodya JG, Srivastava S, Gumbo T. Meta-analysis of clinical studies supports the pharmacokinetic variability hypothesis for acquired drug resistance and failure of antituberculosis therapy. *Clin Infect Dis* 2012;**55**:169–77.
- Wilkins JJ, Langdon G, McIlleron H, Pillai G, Smith PJ, Simonsson US. Variability in the population pharmacokinetics of isoniazid in South African tuberculosis patients. *Br J Clin Pharmacol* 2011;**72**:51–62.
- Wilkins JJ, Langdon G, McIlleron H, Pillai GC, Smith PJ, Simonsson US. Variability in the population pharmacokinetics of pyrazinamide in South African tuberculosis patients. *Eur J Clin Pharmacol* 2006;**62**:727–35.
- Sturkenboom MG, Mulder LW, de Jager A, van Altena R, Aarnoutse RE, de Lange WC, et al. Pharmacokinetic modeling and optimal sampling strategies for therapeutic drug monitoring of rifampin in patients with tuberculosis. *Antimicrob Agents Chemother* 2015;**59**:4907–13.
- Denti P, Jeremiah K, Chigutsa E, Faurholt-Jepsen D, PrayGod G, Range N, et al. Pharmacokinetics of isoniazid, pyrazinamide, and ethambutol in newly diagnosed pulmonary TB patients in Tanzania. *PLoS One* 2015;**10**:e0141002.
- Marais BJ. The global tuberculosis situation and the inexorable rise of drug-resistant disease. *Adv Drug Deliv Rev* 2016;**102**:3–9.
- Skrahina A, Hurevich H, Zalutskaya A, Sahalchuk E, Astrauko A, Hoffner S, et al. Multidrug-resistant tuberculosis in Belarus: the size of the problem and associated risk factors. *Bull World Health Organ* 2013;**91**:36–45.
- Furin J, Cox H. Outbreak of multidrug-resistant tuberculosis on Daru Island. *Lancet Respir Med* 2016;**4**:e40.
- Espinal MA. The global situation of MDR-TB. *Tuberculosis (Edinb)* 2003;**83**:44–51.
- Kendall EA, Fofana MO, Dowdy DW. Burden of transmitted multidrug resistance in epidemics of tuberculosis: a transmission modelling analysis. *Lancet Respir Med* 2015;**3**:963–72.
- Jiao WW, Liu ZG, Han R, Zhao XQ, Dong F, Dong HY, et al. Prevalence of drug resistant *Mycobacterium tuberculosis* among children in China. *Tuberculosis (Edinb)* 2015;**95**:315–20.
- Falzon D, Mirzayev F, Wares F, Baena IG, Zignol M, Linh N, et al. Multidrug-resistant tuberculosis around the world: what progress has been made? *Eur Respir J* 2015;**45**:150–60.
- Kim J, Kwak N, Lee HY, Kim TS, Kim CK, Han SK, et al. Effect of drug resistance on negative conversion of sputum culture in patients with pulmonary tuberculosis. *Int J Infect Dis* 2016;**42**:64–8.
- Moodley R, Godec TR. Short-course treatment for multidrug-resistant tuberculosis: the STREAM trials. *Eur Respir Rev* 2016;**25**:29–35.
- Trauer JM, Denholm JT, McBryde ES. Construction of a mathematical model for tuberculosis transmission in highly endemic regions of the Asia-Pacific. *J Theor Biol* 2014;**358**:74–84.
- MacLean RC, Vogwill T. Limits to compensatory adaptation and the persistence of antibiotic resistance in pathogenic bacteria. *Evol Med Public Health* 2014;**2015**:4–12.
- Dye C, Espinal MA. Will tuberculosis become resistant to all antibiotics? *Proc Biol Sci* 2001;**268**:45–52.
- Cohen T, Jenkins HE, Lu C, McLaughlin M, Floyd K, Zignol M. On the spread and control of MDR-TB epidemics: an examination of trends in anti-tuberculosis drug resistance surveillance data. *Drug Resist Updat* 2014;**17**:105–23.
- Ragonnet R, Trauer JM, Denholm JT, Marais BJ, McBryde ES. High rates of multidrug-resistant and rifampicin-resistant tuberculosis among re-treatment cases: where do they come from? *BMC Infect Dis* 2017;**17**:36.