

# PETER MILLMAN AND THE STUDY OF METEOR SPECTRA AT HARVARD UNIVERSITY

**Steven Tors**

*Agincourt Collegiate Institute, 2621 Midland Avenue, Toronto,  
Ontario, Canada.*

E-mail: steven.tors@tel.tdsb.on.ca

and

**Wayne Orchiston**

*Centre for Astronomy, James Cook University, Townsville,  
Queensland 4811, Australia.*

E-mail: Wayne.Orchiston@jcu.edu.au

**Abstract:** During the 1930s meteor astronomy entered a new era when the Canadian astronomer, Peter Millman, began investigating the spectra of meteors for his post-graduate studies at Harvard University. Whilst experimenting with different lenses, prisms, shutters, photographic plates, and observational techniques, Millman constructed a number of different meteor spectrographs, and by conducting systematic photographic surveys between November 1931 and February 1933 almost tripled the number of meteor spectra known to exist. Through these efforts, in less than two years he was responsible for single-handedly launching a whole new field of meteor investigation.

**Keywords:** Peter M. Millman, Harvard University, meteor astronomy, meteor spectra

*"Goe, and catche a falling starre."* John Donne  
(quoted in Levy, 2001: 46).

## 1 INTRODUCTION

Throughout the millennia human beings have seen and wondered at bright streaks of light blazing across the sky, stars seemingly tumbling from their celestial realms. For centuries these shooting stars, or meteors, were thought to be a component of the Earth's atmosphere, and their extraterrestrial origin was only established at the end of the eighteenth century (see Beech, 1995). Excellent summary histories of meteor astronomy have been published by Hughes (1982; 1990). Meanwhile, Olivier (1925) provides a detailed yet very readable account of the state of meteor astronomy in 1925 and Lovell's (1954) masterful *Meteor Astronomy* documents the main advances made during the nineteenth century and first half of the twentieth century. Beech (1992: 218) reminds us that

Our present understanding of the meteoric phenomena has not been won easily. Just as the other branches of science have had to claw their way from the pit of ignorance, so meteor astronomers have had to founder and flail in their quest to understand the humble shooting star. It is along the tortuous path that joins the most ancient of times with the present that the makings of meteor astronomy are found.

The aforementioned books by Lovell and Olivier reveal that through into the 1920s astronomers were concerned with establishing the magnitudes, paths, heights and velocities of sporadic meteors. Reported velocities posed a special problem and debate raged around whether these meteors originated in the Solar System or hailed from interstellar regions. "Criticism and counter-criticism effectively led to an impasse ..." (Lovell, 1954: 247) which was only resolved with the advent of radar meteor astronomy.

Meteor streams were the other special area of interest for astronomers, as they sought to identify different showers, determine hourly rates and meteor velocities, calculate orbital elements of the streams, and investigate radiant positions—especially those that moved

with the passage of time. Some streams, certainly not all, were known to be associated with comets.

These early investigations of sporadic and shower meteors relied almost entirely upon naked eye observations, for although photography had been introduced to astronomy as early as 1840 (Lankford, 1984; Norman, 1938) and spectroscopy in the early nineteenth century (Hearnshaw, 1986), initially neither of these tools was applied systematically to the study of meteors (at least in combination). Consequently, as late as 1930 only eight photographs of meteor spectra were known to exist anywhere in the world (Millman, 1932), and these had not been carefully studied so they had not contributed in a meaningful way to meteor science.

One of the men responsible for changing this situation was a young Canadian astronomer, Peter Millman. In 1929 he headed to Harvard College Observatory where he subsequently established a systematic program to collect all known photographs of meteor spectra, add to their number, and glean from them all he could learn about these extraterrestrial visitors. In just two years he was responsible for capturing 15 new meteor spectra, almost tripling the number in existence. By the end of this pioneering period, he had developed innovative techniques for the study of meteors and had begun to lay the foundation for a specialized branch of science that would expand greatly following World War II.

## 2 THE EARLY LIFE OF PETER MILLMAN

Peter Mackenzie Millman was born on 10 August 1906 in Toronto, Canada, the eldest son of Robert and Edith (Middleton) Millman. When Peter was 2 years old his parents moved the family to Japan to engage in missionary work with the Anglican Church of Canada. It was in that Far Eastern country over the following sixteen years that Peter discovered a love for the heavens and an interest in astronomical observing:

There, though at a latitude but little less than New York, the sky seems sometimes to be filled with stars seldom observed here, and the brilliant Canopus rises for an hour or more above the southern horizon to add his luster to the brilliancy of the winter heavens. (Millman, 1926: 198).

Observations of Mars made from the slopes of Mount Fuji in the summer of 1924 led to his first professional publication at the age of 20, in the *Journal of the Royal Astronomical Society of Canada* (Millman, 1926).

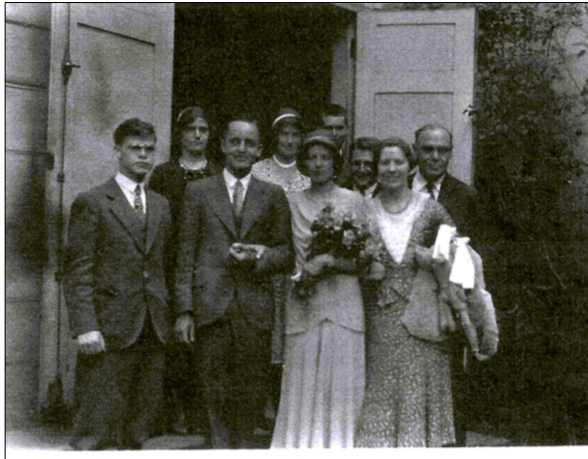

Figure 1: Peter Millman and Margaret Gray, on their wedding day; Shapley is on the far right (Millman Family records).

Returning to Canada, Millman attended the University of Toronto, completing his B.A. in 1929. During the summers in these years he worked as an assistant at the Dominion Astrophysical Observatory in Victoria, British Columbia. This work led to Peter's first original, though modest, scientific publication, a reduction of binary star data (Millman, 1928a). During his undergraduate years, Millman also published a paper on "The quality of the light of the eclipsed Moon" (Millman, 1929) and a brief note on an interesting mirage seen on 31 July 1927 in the Strait of Juan de Fuca near Victoria (Millman, 1928b). These were the modest beginnings of a career that would soon see the pioneering of a virtually new branch of astronomy—meteor spectroscopy (Halliday, 1991). The beginning of that path lay to the south, in Cambridge, Massachusetts.

### 3 THE BIRTH OF METEOR SPECTROSCOPY AT HARVARD

When Millman completed his undergraduate degree at the University of Toronto, no Canadian universities offered graduate programs in astronomy (Jarrell, 1988), so he headed to the United States in order to further his studies. He enrolled at Harvard University (Hoffleit, 1999; Hogg, 1990) at a time when a number of men and women, now well-known in astronomical circles, were on the staff or were fellow graduate students. These included Cecilia Payne, Helen Sawyer (later Hogg), Ernst Öpik and Fred Whipple.

The Harvard program was headed by Harlow Shapley, the famous astronomer who had used globular clusters to identify the center of the Milky Way and determine the Earth's location within the Galaxy. Shapley became a mentor to the young student.

While in Cambridge, Millman had to check into the University's Stillman Infirmary for a tonsillectomy, and this is where he met a Canadian nurse, Margaret (Peggy) Gray (Crook, 1989). On 10 July 1931 the young couple married (Figure 1). Peggy's parents were forced to remain in Nova Scotia, so it was Harlow Shapley who stepped in and gave away the bride (Barry Millman, personal communication, 2006).

#### 3.1 Harlow Shapley and the Importance of Meteor Research

Shapley at this time had an interest in meteors, primarily as they related to the overall nature and structure of the Universe. Speaking before the National Academy of Sciences of the United States, he remarked that

The nature of the interstellar and intergalactic media through which radiation, stars, clusters, and galaxies move is found to be of so much significance in our understanding of galactic distances and structure that fundamental research on the contents of space has become necessary. For several years at the Harvard Observatory we have studied one aspect of the problem—the meteors. Investigation of these multitudinous small bodies directly bears not only on knowledge of their own physical nature and their place in the cosmic structure, but as well on the question of the content of interstellar space; and indirectly such investigations may contribute to the solution of the general problem of "planetesimals" in the origin of the solar system, and of the structure of the upper terrestrial atmosphere. (Shapley et al, 1932: 16).

He recognized that "An indication of the significant role that meteoric matter may play in the universe only begins to appear when we correlate terrestrial fireball phenomena, spectrophotometry by the newer methods, and the study of nebulae." (Shapley, 1928: 101). Shapley must also have been aware that some meteor showers were associated with comets and that the spectral characteristics of comets had been known for decades (e.g. see Chambers, 1910; Olivier, 1930; Young, 1888). Meteor spectra, therefore, would allow comparisons to be made, and the chemical composition of those meteors that did not result from cometary disintegration could be established. By combining photography and spectroscopy, technological advances now allowed the emergence of a whole new field of meteoric investigation.

In spite of the stated importance of meteor spectra, at a 1932 conference on astrophotographic problems Shapley (1932: 611) reported that "In the Harvard collection only about one spectrum plate in 20,000 shows spectra of meteors, but with special cameras it is hoped to get one spectrum out of every fifty to a hundred attempts."

Shapley was keen to pursue this line of enquiry, and he directed Millman's doctoral research in this direction. In the autumn of 1931 he assigned the young Canadian the task of collecting and analyzing meteor spectra. At this time, little had been published on meteor spectra. During the second half of the nineteenth century a number of well-known astronomers, including A.S. Herschel, Konkoly and Secchi had reported making fortuitous visual observations of meteor spectra in the course of other observing projects, and their combined conclusions were summarized by Millman in 1932:

1. The observed types of spectra seemed to show no particular correlation with the radiant to which the meteor belonged.
2. As we would expect, the greatest detail was observed in the spectra of the brightest meteors.
3. As far as can be judged the trains had the same types of spectra as the nucleus but of much lesser intensity. For this reason lines could often be picked out in the train that could not be seen in the nucleus owing to the great strength of the continuous spectrum in the latter. In the fading train only the strongest parts of the spectrum remained.
4. The nucleus of a meteor almost always had an apparent continuous spectrum, usually with one or more colours abnormally strong. The train spectrum showed the continuous characteristic in a much weakened condition and had bright lines corresponding to the strong parts of the nuclear spectrum. The continuous appearance, however, was often lacking altogether in the train.
5. With the exception of the continuous spectrum, the most general feature of meteor spectra was a strong orange-yellow line which appeared in at least three quarters of the observations and was commonly attributed to sodium.
6. After the yellow line, the next most common feature was a strong green line similar to the magnesium green line. This would appear with or without the yellow line and, when definitely predominant, gave the meteor an emerald green colour.
7. Other bright lines frequently appeared. Two lines in the red near the positions of the lithium lines occasionally occurred, also two more lines in the green which appeared with or without the red lines. In a few meteors a large number of bright lines were observed in the green and blue. (Millman, 1932: 113-114).

The successful visual characterization of the spectrum of an unexpected transient phenomenon like a meteor was an observational challenge—to say the least—and what was clearly required was a permanent record. Yet despite the fact that only eight photographs of meteor spectra were known in 1930—obtained mostly by chance—Millman immersed himself in the task of carefully investigating these. His primary aim was to establish the wavelengths and intensities of the visible emission lines, and identify these with known elements. This would provide valuable pointers to the chemical composition of these eight meteors.

### 3.2 Millman's Analysis of Existing Meteor Spectra

Millman (1932) listed these known meteor spectra chronologically from I to VIII, and some information about them is presented here in Table 1.<sup>1</sup>

In his long and masterful 1932 paper, published by Harvard College Observatory, Millman (1932: 114) summarized the already-published accounts relating to the first eight spectra in Table 1. Emission lines of hydrogen were identified in Spectrum I. The strongest emission lines in Spectrum II were the H and K lines of calcium, but weaker lines were associated with magnesium and potassium. Five of the lines in Spectrum III were thought to be due to helium, and a sixth line to thalium. Eighteen lines were identified in Spectrum IV, the two brightest being the H and K lines of calcium. Nothing had been published about Spectra V, VI and VII, while the two brightest lines in Spectrum VIII were (once again) the H and K lines of calcium, with all remaining lines associated with iron.

Millman (1932: 118-119) then proceeded to carry out his own analysis of these eight spectra, but this

proved a non-trivial exercise. He only had access to two of the photographs (for Spectra I and V), and in the remaining cases he had to rely on direct copies, some of which were not distinct enough for easy analysis.

The work of measuring the spectral lines for these recordings had only been done for three of the eight spectra and Millman had to make the actual measurements for the others. This was no easy task, primarily due to the low resolution and the limited dispersion in the photographs, "... ranging from 150 to 450 angstrom units per mm. between H $\gamma$  and H $\zeta$ ." (Millman, 1933d: 152).

Measuring the intensities of the spectral lines also proved to be problematic. For four of the spectra, Millman was able to make use of a Moll microphotometer. Calibration curves were obtained from stellar spectra where they were present on the photographic plates. In general, A0 stars were employed for this, a small correction factor having to be employed where different classes of stars had to be used. In one case no stellar spectra at all were available and an estimate was made by comparing the meteor spectrum directly with stellar images. Millman (1932: 117) was forced to concede that all of these methods left something to be desired:

It must be admitted that none of the above calibrations were of the most satisfactory type but they were the best available under the circumstances, and while not yielding intensities of a high degree of accuracy, the intensities should be more trustworthy than eye estimates.

Table 1: Known photographs of meteor spectra, as at early 1932 (after Millman, 1934c: 279).

No	Date	Place	Shower
I	18 June 1897	Arequipa, Peru	
II	11 May 1904	Moscow, Russia	
III	12 August 1904	Moscow, Russia	Perseid
IV	12 August 1907	Moscow, Russia	Perseid
V	18 May 1909	Arequipa, Peru	
VI	10 August 1920	Mt Wilson, USA	Perseid
VII	7 March 1924	Mt Wilson, USA	
VIII	29 Sept 1924	Bergedorf, Germany	
XI	9 January 1913	Harvard College Observatory, USA	

The other spectra were not clear enough to be examined by the microphotometer. In these cases Millman was required to rely on eye estimates. However, in spite of all these problems, "A set of relative positions and intensities for the lines in each of the nine spectra was thus obtained." (ibid.).

More problems remained to be solved, however, for in order to compare the eight different spectra, Millman had to account for the different dispersion scales used in each case. Three of them had previously been provided, by Schwassmann for Spectrum VIII and Blajko for Spectra II and III. Millman determined the dispersions for the remaining photographs by using the positions of three hydrogen lines (usually H $\beta$ , H $\gamma$  and H $\delta$ ) for anywhere from four to thirteen early type stars that were present on the images near the meteor trails. From the values for these lines, he determined a Hartmann dispersion formula that allowed for the calculation of the distance between any two wavelengths in the meteor spectra. Once the Hartmann formula had

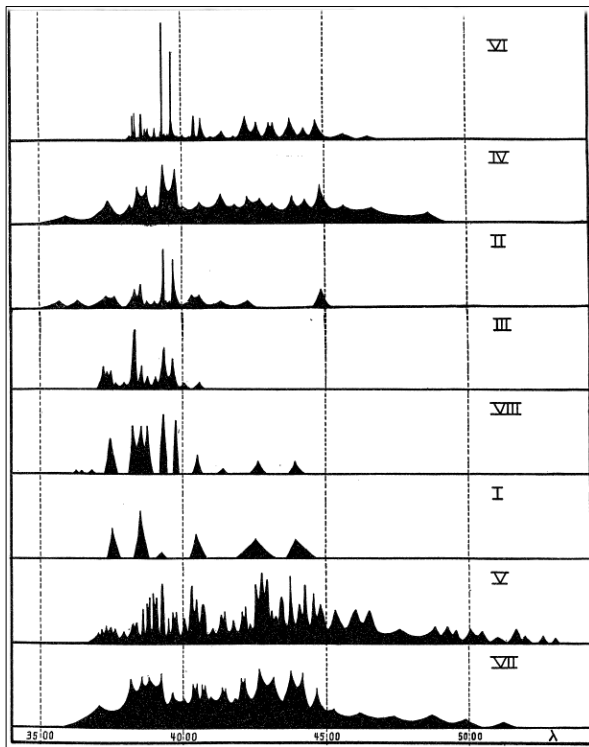

Figure 2: Distribution of spectral lines in the eight historical photographs of meteor spectra (adapted from Millman, 1932: 133).

been determined, it could be used to identify all wave-lengths in the meteor spectra based on a single wave-length determined by comparison with laboratory data (Millman, 1932).

Millman's efforts in analyzing prior meteor spectra were so meticulous that he was able to correct an earlier error. Spectrum III, obtained by Blajko in Moscow on 12 August 1904, appeared to show a significantly different pattern of lines than the other existing spectra. Millman (1932: 119-120) demonstrated that in the initial analysis, the spectrum had been placed on the dispersion scale too far to the red, and that correcting for this error brought the spectrum into correspondence with the others:

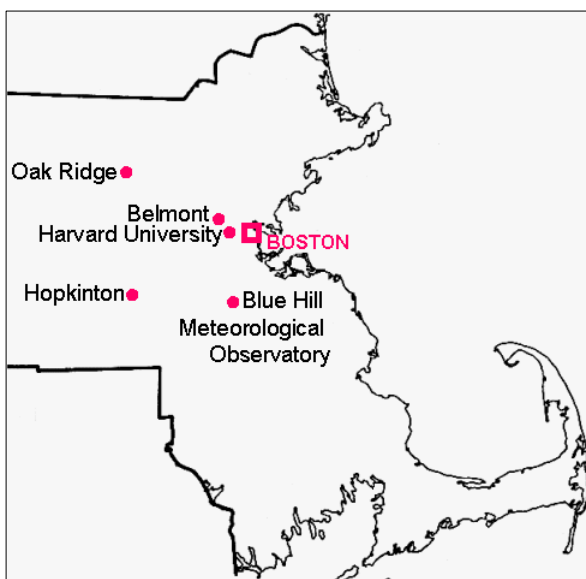

Figure 3: Massachusetts localities mentioned in the text.

Spectrum III was now the only one for which no satisfactory final wave-lengths had been determined. Blajko determined preliminary wave-lengths from measurements of the chart plate and then, by shifting these preliminary wave-lengths by 10 to 14 Angstroms he found coincidences with five helium lines. This explained five of the meteor spectrum lines and gave final wave-lengths for the others but resulted in no further satisfactory identification. All possible combinations of elements were tested by the writer in an attempt to explain the other lines in this spectrum, without success. The identification with helium seemed rather uncertain from a theoretical standpoint, as helium is only present in meteorites in very minute quantities, and the excitation potential of the helium lines is high, so that they are not produced easily. The lines might arise from atmospheric helium but no evidence of atmospheric lines appears in the other spectra.

It was noted that, if the whole spectrum could be shifted on the dispersion scale about fifty Angstroms to the violet, there would be no difficulty in identifying all the lines. To test the possibility that the spectrum was originally placed too far to the red on the dispersion scale, measurements on the chart plate were made by the writer to determine an approximate wave-length of the line  $\lambda 4017$  in Blajko's preliminary table. Using two stars on either side of the meteor trail, four values were obtained, giving a mean wave-length  $\lambda 3980 \pm 2$ . Now, by shifting this preliminary determination by eleven Angstroms, coincidences of all the meteor lines with known lines appearing in other meteor spectra were obtained. The original error in the preliminary wave-lengths may have arisen from a slight difference in scale between the chart and spectrum plate, from poor images on the chart plate, and from the fact that one of the bright stars near the meteor trail is a double and hence the overlapping of the spectra must be allowed of in using it as reference point.

Millman (1932: 118-119) also disputed some of the other conclusions reached by the earlier researchers. He found that

Spectra II, IV, and VIII each contained two lines brighter than all the others and, when the preliminary wave-lengths were computed, it was found that they closely agreed with those of the H and K lines of ionized calcium ... [Spectrum VI] exhibited two bright lines of similar appearance ... [and] It was assumed ... that these were [also] the H and K lines ...

Spectra I, III, V, and VII were more difficult cases as none of them showed any outstanding feature which could be at once recognized ... [However] On comparison with the spectra of various elements common in meteorites the lines in Spectrum V were seen to be grouped similarly to the strongest parts of the iron spectrum ... [and] The resemblance between the two spectra ... seemed to justify proceeding on the assumption that the majority of lines in Spectrum V were produced by iron. This view was greatly strengthened by a consideration of Spectrum VII. The latter was at once seen to be very similar to Spectrum V ...

The collective evidence of the presence of iron in all nine spectra has seemed so strong, however, that the writer has advanced it as the best and most probable identification of the majority of lines ...

The six lines of Spectrum I seemed to agree well with the iron spectrum ...

From his investigation of the wavelengths of the various spectral lines in Spectra I-VIII, Millman (1932: 132) was able to demonstrate that they were predominantly produced by iron and calcium, with magnesium, manganese, chromium, aluminium and possibly silicon

responsible for some lines in a few of the spectra. Interestingly, the three spectra associated with Perseid shower meteors were "... not noticeably more alike than are the other six. III and VI both show magnesium definitely and all three show strong calcium." (Millman, 1932: 136). Figure 2 shows the wavelength distribution of the identified lines in the eight spectra.

Despite this promising start, Millman (1935a: 149) saw the importance of increasing his observational data set, and in 1931 he began a quest to obtain more photographs of meteor spectra.

### 3.3 Initial Observations at the Blue Hill Meteorological Observatory

In order to achieve this, Millman set up four cameras equipped with prisms at the nearby Blue Hill Meteorological Observatory, whose situation "...is far superior to Cambridge since it has an altitude of 635 feet and is fairly well removed from city lights and haze." (Millman, 1932: 115). For Massachusetts localities mentioned in the text see Figure 3.

Millman intended to begin his observing program with that year's Leonid meteor showers. However, not for the last time in his career, the weather proved uncooperative with a week of heavy cloud cover. Observing sessions were postponed until later in the year. A total of 120 plates was eventually exposed for a cumulative time of 85 hours over five nights (11 and 13 November, and 7, 12 and 14 December 1931). During the November observations the cameras were directed towards the radiant of the Leonid showers while during December they were pointed in the region of the Geminid radiant. In each case visual observations were made concurrently with the photographic work. This effort resulted in the recording of the ninth spectrum then known to exist (see Figure 4):

A bright meteor spectrum was photographed with Camera A on the night of December 14.<sup>2</sup> This meteor was slow and fully as bright as Jupiter. No other meteors of similar magnitude were observed to cross the fields covered by the cameras and no other meteor was photographed. (Millman, 1932: 115).

In fact, another meteor *had* been photographed, and was discovered later when Millman carried out a second inspection of plates exposed on 12 December 1931 during the Geminid shower. More meteor spectra would follow as Millman completed his doctorate under a fellowship from the Royal Society of Canada, and he then remained at Harvard for one more year as Agassiz Scholar (Millman, n.d.).

### 3.4 Observing at Flagstaff

Between 25 February 1932 and 26 February 1933, Millman helped arrange for the operation of three spectrographs at Flagstaff, Arizona, as part of the Harvard-Cornell Meteor Expedition of 1931-1933.

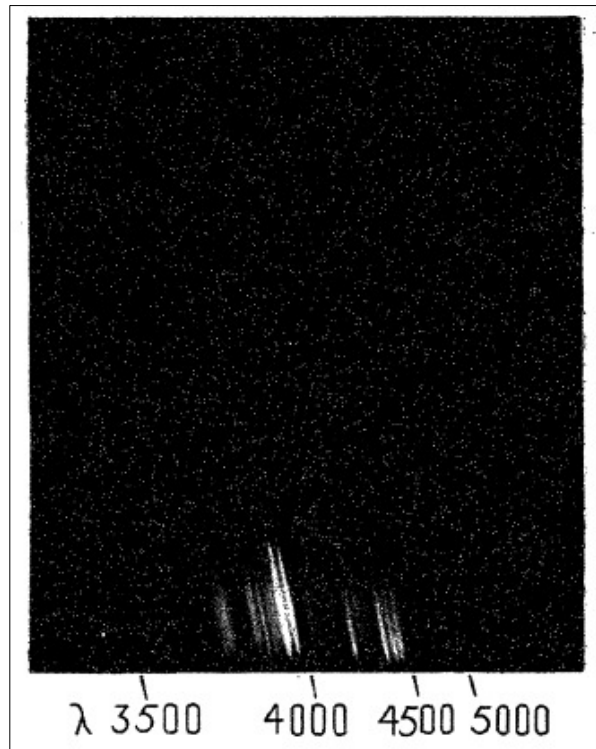

Figure 4: The first meteor spectrum photographed by Peter Millman, on 14 December 1931 from the Blue Hill Meteorological Observatory (after Millman, 1932).

Each of these cameras covered approximately 1400 square degrees of the sky and was directed at altitudes of thirty degrees. Two cameras faced south and one towards the north, with each aligned so that the prisms dispersed light horizontally. Exposure times generally ranged between one and two hours. In all, 788 plates were exposed over a total of almost 1351 hours, resulting in the capture of five meteor spectra (Millman, 1935a).

During the 1932 Leonid showers, additional cameras were set up at various locations. Millman observed with seven from Oak Ridge, Massachusetts, one of which had a rotating shutter. The nearby stations at Hopkinton and Belmont (see Figure 3) formed a triangle with ~35km sides for height determination by triangulation of any meteors observed simultaneously from more than one station. Observations were also made in Flagstaff and at Fort Worth in Texas. Non-spectrographic observations were also conducted from Brooklyn, New York, the meteorological station on Mt. Washington, and by Peter Millman's brother, John, in Saskatoon, Canada (Millman, 1933b). This effort resulted in another 96.8 hours of exposure time distributed across 398 plates, and produced eight more meteor spectra. In less than two years, Millman succeeded in increasing the total number of known meteor spectra from 8 to 23 (see Table 2).

Table 2: The fifteen new meteor spectra photographed by Millman during 1931-1933 (after Millman, 1932; 1935a).

U.S. Locations	Dates	Number of Spectrographs	Plates Exposed	Hours Exposed	Meteor Spectra Recorded
Blue Hill, MA	11-13 November; 7-14 December 1932	4	120	85	2
Flagstaff, AZ	25 February 1932 - February 1933	3	788	1351	7
Oak Ridge, MA	15-18 November 1932	7	224	61	5
Hopkinton, MA	15-16 November 1932	3	90	14.4	0
Belmont, MA	15 November 1932	1	11	4	0
Ft. Worth, TX	15-16 November 1932	2	11	6	1

#### 4 DEVELOPING EQUIPMENT AND METHODS FOR METEOR SPECTROSCOPY

In beginning his meteor spectrophotography program at Harvard, Peter Millman was virtually developing a new branch of astronomy. Accordingly, he could not simply rely on methods developed by others in overcoming the many practical difficulties he faced. In attempting to systematically photograph such transient phenomena as meteor spectra, he needed to determine for himself what equipment and techniques would successfully accomplish his goals. He did this through an extensive program of trial and error that eventually allowed him to select suitable lenses, prisms, shutters, and photographic plates, as well as methods for focusing and directing his cameras. Shapley made sure that the Harvard College Observatory supplied the necessary equipment, either by approving the purchase of new items or by drawing on its existing collection of surplus optical components.

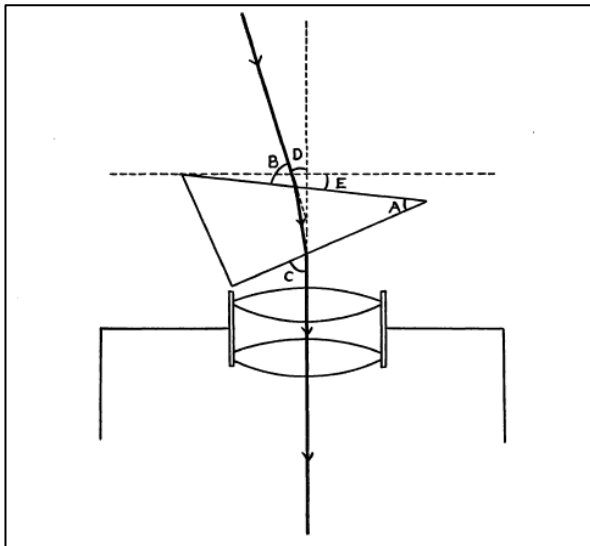

Figure 5: Diagrammatic representation of the optical system of Millman's meteor spectrograph, showing the prism completely covering the camera lens (after Millman, 1933a: 300).

##### 4.1 Lenses and Prisms

The spectrographs Millman developed during the pioneering years employed prisms that combined with the lenses of his cameras to provide his optical systems. His primary concern in their function was to maximize the dispersion of the meteor light in order to provide the greatest opportunity for identifying and analyzing the spectral lines. As he stated, "To photograph one meteor spectrum in good definition is far more important than to secure ten that are of only average quality." (Millman, 1933a: 301). He therefore chose the components of his optical systems carefully in order to maximize the information that would be revealed.

When selecting a lens, Millman needed to find a balance between dispersion and speed. A slow lens would produce maximum dispersion, yet would produce significant absorption of the meteor's light. A fast lens would minimize absorption but would produce little dispersion:

The difficulty encountered here was the small dispersion and low resolution that it was necessary to work

with, the dispersions ranging from 150 to 450 angstrom units per mm. between  $H\gamma$  and  $H\zeta$ . (Millman, 1935a: 152)

Through his observing experience at Harvard, Millman concluded that the practical range of dispersion for his meteor spectra was 0.5 to 1.5 mm from  $H\beta$  to  $H\gamma$ . The upper limit for achieving such dispersion he found to be a focal ratio of  $f/4.5$ . Early in this period Millman (1933a) achieved his best results with two  $f/4.5$  lenses, the Zeiss Tessar and the Voigtlander Skopar, but he would later also successfully employ Xenar Schneider, Moia Helimar Series I, Zeiss Tessar IC and Boyer Saphir lenses (Millman, 1932).

The same balance between dispersion and speed needed to be achieved with the prism to be used. Millman's prisms were of glass or high-quality quartz with a refracting angle of  $\sim 30^\circ$ . If it was much smaller than this, the prism would not produce sufficient dispersion of the spectral lines to allow for identification; if it was much larger, the absorption of the glass or quartz would severely reduce the speed of the system (Millman, 1933a).

Once a proper lens and prism had been selected, they needed to be mounted correctly to create an efficient spectrograph. The prism was held in front of the lens in such a way as to cover it entirely (Figure 5). For an  $f/4.5$  lens of 25 cm focal length, the most efficient prism over the whole photographic spectrum would be one of ultraviolet crown glass set at an angle of  $30\text{--}40^\circ$ . Alternatively, a light flint prism set between  $20^\circ$  and  $30^\circ$  degrees could be used, although this was not as efficient at short wavelengths. A suitable angle could be determined empirically by testing the refraction of the light by the prism while still outside of the spectrograph:

... the angle of minimum deviation, may be found to the required degree of accuracy by setting the prism on edge on a large piece of white paper on which has been drawn a single straight line and then studying the way the light is bent by observing this line through the prism. (Millman, 1933a: 302).

However, although the angle of mounting was important, of even greater concern was the stability of the prism:

The exact angle at which the prism is set, however, is not nearly so important as making sure that the prism is firmly mounted so that its position with respect to the lens will not vary in the slightest throughout the course of the observation. This last point cannot be too strongly stressed. (Millman, 1933a: 302).

##### 4.2 Rotating Shutters

Millman also made use of a rotating shutter, a piece of equipment introduced at Harvard Observatory by W.J. Fisher for the photographic recording of meteors (see Lovell, 1954: 198) and passed on to Millman in the autumn of 1932 (Millman and Hoffleit, 1937). The shutter was driven by a synchronous motor, covering the lens a set number of times (typically 20 to 30 times) per second. This effect broke the image of the meteor train on the photograph into segments, allowing computation of the apparent angular velocity of the meteor based on the rotation rate of the shutter. If the meteor was simultaneously observed from a second station, an actual velocity could be determined (Mill-

man, 1936a). Important information could also be revealed about the persistent train of the meteor. So successful did Millman (1936a: 103) find this method that he expressed the hope that, "... all meteor photographers will, where possible, equip their cameras with rotating shutters."

#### 4.3 Plates

Shortly after embarking upon his work in meteor spectroscopy, Millman (1935b: 116) wrote:

Important advances in astronomical photography are very closely dependent upon improvements in the speed and grain of photographic emulsions. Nowhere is this truer than in meteor photography where increased efficiency cannot be attained by the use of larger instruments or longer exposures. The meteor photographer should always be on the lookout for plates which combine great speed with fairly small grain.

From the earliest days of his work, Millman was true to his own advice. His difficulty arose from the fact that because spectrophotography involved recording images of individual wavelengths, the photographic plate used needed to be sensitive across a broad band of the spectrum. No single film was entirely satisfactory and Millman constantly experimented with new plates.

To record around the blue end of the spectrum, Millman began by employing the Cramer Hi-Speed plate which was fastest in the blue region but was well-suited for photography only between  $\lambda 3800$ - $\lambda 4800$ . Another film, the Cramer Iso-Presto had a similar blue sensitivity and also added a band in the yellow-green range, but Millman found it considerably more prone to sky fog. Barnet produced the Super Press Plate which was slightly faster in the blue region than the earlier Cramer Hi-Speed and also showed some sensitivity to yellow wavelengths (Millman, 1933a).

Although all Millman's spectra were captured using Cramer plates—5 on Hi-Speed and 10 on Iso-Presto (Millman, 1932)—the best plate technically was probably Ilford's Hypersensitive Panchromatic plate, which had been specially sensitized for meteor work. Millman (1933a: 303) tested it and found these plates to be highly satisfactory:

They are practically as fast in the blue as the Hi-Speed and have a comparatively even gradation through the green and yellow with a slight maximum near  $\lambda 6000$ . They seem particularly suitable plates for covering the whole spectrum except for the deep red, and should be well adapted to photographing the sodium yellow and magnesium green lines which, although the most prominent parts of the visual spectrum of meteors, have not yet been photographed.

Films suitable for recording the visual spectrum at long wavelengths proved more difficult to find and in fact Millman would not obtain satisfactory films until shortly after his departure from Harvard, when he returned to his native Toronto. The red region was of particular interest to Millman because visual observers in the nineteenth century had reported strong lines in this part of the spectrum but those lines had not been identified photographically and their source remained uncertain. To identify them, "... a good photographic meteor spectrum extending to  $\lambda 6500$  or beyond is the only solution." (Millman, 1934a: 35). It was not until 1935 that Millman found such a film, when the Ilford H $\alpha$  II plate came on the market. It was sensitive in the

red region as far as  $\lambda 6800$ , with peak sensitivity close to the H $\alpha$  line. Millman (1934a: 36) remarked that this film "... is very fast for a plate sensitive so far into the red."

#### 4.4 Focusing and Directing the Camera

Focusing the spectrograph was a problem. Star trails could not be used since in spectroscopy the trails were dispersed and not sharp enough to determine if the focus of the camera was properly adjusted. Millman overcame this challenge and focused his spectrograph by directly judging the sharpness of stellar spectra themselves. He generally considered the prominent hydrogen Balmer lines, commonly assessing them in the bright spectra of Sirius in the winter and Vega in the summer (Millman, 1937).



Figure 6: A Gaertner measuring engine, like the one used by Millman (courtesy: McCormick Museum).

In addition to proper focusing, Millman (1933a) also pointed out the importance of the selection of the direction in which to aim the camera. He suggested that on an average night any region of the sky  $>30^\circ$  above the horizon was acceptable, with some slight advantage for spectrophotography of altitudes around  $40$ - $45^\circ$ .

While photographing during a meteor shower, it was best to aim the camera near the radiant, "... in spite of the fact that casual observations would lead one to think that the brightest meteors appear at some distance from the radiant." (Millman, 1933a: 303-304). This is because the slow angular velocity close to the radiant produced better photographic results, in spite of the more spectacular visual appearances at a greater distance. Millman (1933a) also suggested that, if the radiant of the shower was near to one horizon, extra cameras could be usefully directed at the opposite horizon.

In all cases, since the most likely direction of motion of meteors is downward, the spectrograph's prism was positioned with the thin edge vertical (*ibid.*).

#### 5 ANALYSIS OF THE NEW SPECTRA

To Millman, success in obtaining meteor spectra was not an end in itself, as these were research tools that would yield information on the chemical composition of meteors and hint at their origin within the Solar System, and they could also be used to investigate the

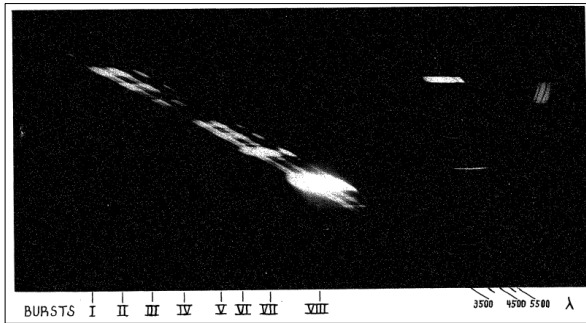

Figure 7: Photograph of Spectrum XXIV, captured by Millman on 26 February 1933 (after Millman, 1935a: 165).

properties of the ionosphere (Millman, 1933d). To do this Millman carried out a detailed analysis of each of the newly-obtained spectra, recording the positions and intensities of the different spectral lines, and identifying the associated elements.

He started by using a measuring machine, either a Hilger or more commonly a Gaertner single-screw measuring engine (Figure 6), a device designed by Frank Schlesinger in the early part of the twentieth century and built by the Gaertner Scientific Corporation of Chicago. The Gaertner engine was designed to allow for rapid measurements by relying on a single bisection by the microscope reticle lines which would then permit the measurement to be read from a dial. A rotating stage was provided to allow for measurements in different coordinates. Finally, to deal with the problem of measuring images with breadth, a reversing eyepiece was provided that would reverse the image  $180^\circ$ , so that measurements could be made from both sides of an object and then averaged. Millman took full advantage of these features in carrying out his analysis of the nine meteor spectra available to him:

The spectra were so placed on the machine that the dispersion was parallel to the motion of the screw, since in most cases the meteor trail changed greatly in intensity and quality throughout its length. By this arrangement the lines of the meteor spectra were not necessarily perpendicular to the direction of the screw motion, but it had the advantage that a single set of measures represented lines impressed by the meteor simultaneously. The cross wire was turned parallel to the meteor spectrum lines and these were made to appear perpendicular in the field of view by use of a reversing eyepiece. Three settings were made on each line in a spectrum. It was then reversed by means of the eyepiece and the measurement repeated. The mean of

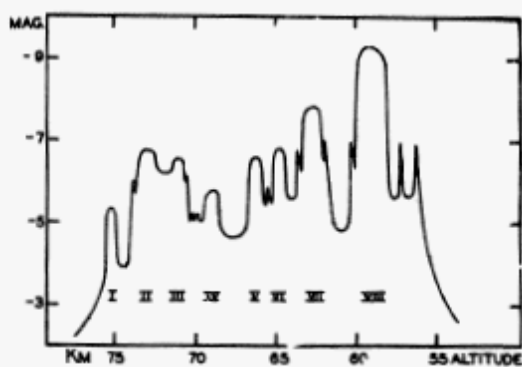

Figure 8: Plot of changes in total intensity along the flight path exhibited by the meteoroid that produced Spectrum XXIV (after Millman, 1935a: 155).

the six settings was taken as the final setting for a line. (Millman, 1932: 117).

Millman thus measured each spectrum at least six times, three times from each end. When possible, dispersions were calculated from stellar spectra visible on the plates. A difficulty arose, however, from differences in the scale of dispersion in different parts of the plates. This was particularly troublesome since many of the cameras used covered a large area of the sky and a significant portion of the spectra were located at the outer edges of the plates. Millman's growing experience with meteor spectrum photography, however, helped him overcome this problem:

Fortunately ... known lines could almost always be recognized by an examination of the spectrum, and slight adjustments to the scale of the dispersion could then be made. This is not the most satisfactory procedure and it was followed only when all the available information concerning the dispersion had been obtained from measures of stellar spectra and where the writer was certain of his line identifications. (Millman, 1935a: 152).

A further difficulty in determining dispersion came from the fact that meteor spectra were generally at some angle to the direction of dispersion. To deal with this, Millman attached a photographic glass reticle to the plate with its lines parallel to the emission lines of a stellar spectrum. Meteor lines were then measured parallel to the reticle lines which served as a zero point.

Another problem related to measuring the intensity of the emission lines. Where possible, the Moll microphotometer was employed for making these readings. Characteristic curves were determined if stellar spectra were suitable, less accurate standard curves if they were not. However, in many cases, sky fog on the plate proved too great for microphotometer measurements to be made, in which case eye estimates had to be relied on (Millman, 1935a).

## 5.1 Spectrum XXIV

As an example of Millman's detailed work, his analysis of the twenty-fourth spectrum, the final one recorded during the Harvard program, may be considered (Figure 7). This spectrum was obtained on 26 February 1933 on the second-to-last plate of the Flagstaff observation program. It was taken on a Cramer Iso Presto plate using a camera equipped with a Boyer Saphir 150 mm f/4.5 lens and a 30-degree Hilger flint prism (Millman, 1935a). Millman (1933c) reports that

The exposure was on the north pole, being one hour in length. The camera was on a stationary mount so that the stars made circular trails about the pole. Polaris is the very bright star in the upper right, about one and a half inches from the edge ... The dispersion is horizontal with the violet end of the spectrum to the left, the red end to the right. The hydrogen lines are clearly visible in the star at the extreme right.

The recorded meteor was estimated to have a visual magnitude that began at +2 and peaked at -9, its duration was 4.5 seconds, and it left a persistent train for 2 seconds. The meteor streak covered just over  $24^\circ$  on the sky. By comparing the photograph taken at Flagstaff and a visual sighting at nearby Padre, it was estimated that the meteor became visible while at a height of about 90 km above the Earth and disappeared



at 52 km altitude. During this fall it showed eight large bursts and numerous smaller ones (Figure 8). Analysis of the spectrum revealed 63 measurable lines. Millman's careful reduction was typical of his work:

Microphotometer tracings of the spectrum were made at twelve points on the trail. They were located with reference to the bursts as follows: before I, I, after I, 2, after 2, 4, after 4, 6, 7, 8, after 8. Twenty two tracings in all were made, two or three slit widths being used at most of these positions. The characteristic curve for the plate was determined from the tracings of eight spectra of stars with known magnitudes. Most of these stars were of Class A, and in the reduction allowance was made for the declination of the star, its class, its distance from the plate center, and the angle which its motion made with the direction of the dispersion. Separate characteristic curves were drawn for each wave-length measured in the stellar spectra, and as all of these were seen to be of the same shape they were combined. The resulting mean characteristic curve has been derived from seventy five points in good agreement. For this reason the writer feels great confidence in the intensity measures of this spectrum and considers them superior to those of any other spectrum studied. (Millman, 1935a: 162-163).

The meteor trail was recorded at an angle of only  $28^\circ$  to the direction of dispersion, requiring the use of a reticle as described above. Millman (*ibid.*) improvised an ingenious method to accomplish this before using the results to determine the intensities at various points along the trail:

The twenty two tracings were measured by means of a reticle formed of accurate graph paper (20 squares to the inch) treated with Vaseline. The reticle was clamped securely over the tracing in a frame and readings in both coordinates made to the tenth of a division. This method is much more rapid and probably more accurate than the usual way of measuring traces. Reduction to magnitudes was made by means of the characteristic curve, converted to tabular form for this purpose. The intensity curve of the meteor spectrum at each of the twelve points was then plotted on a large scale, in terms of magnitudes. The curves obtained from tracings made at the same point but with differing slit widths agreed excellently, the chief difference being the greater resolution given by the narrower slits. The agreement further indicates the reliability of these intensities.

## 6 RESULTS OF THE HARVARD PROGRAM OF METEOR SPECTROPHOTOGRAPHY

Millman's observing program in connection with Harvard College Observatory produced outstanding results (Table 2). In total 1,244 plates was exposed for a cumulative time of 1,521 hours. This work more than doubled the total number of meteor spectrum photographs, adding 15 to the previous total of 9. Such a result translated into one spectrum for every 82.9 plates exposed (requiring an average of 101.4 hours exposure time), comfortably within Harlow Shapley's stated aim of "... one spectrum out of every fifty to a hundred attempts." Of the 24 meteor spectra known by the end of 1933, Millman had been directly involved in capturing at least 7 of them (29%) and had organized the programs that had obtained 8 others (33%), thus accounting for 62% of the meteor spectra then in existence. He also carried out the initial reductions for all these new spectra and re-evaluated the previous spectra, including correcting the incorrect

identification of the emission lines of one of them. Millman clearly had, almost single-handedly, transformed the capture and study of meteor spectra from a haphazard and largely-neglected field into a sound science based on effective methodology.

Millman (1932: 139) noted that his analysis of all these spectra revealed a composition of meteors in keeping with what had been deduced from the analysis of meteorites. All the lines identified could be matched to elements known to be present in meteorites. Iron, nickel, calcium, magnesium, manganese, and chromium were definitely identified and probable identifications were made of sodium, silicon, and aluminium (Millman, 1935a). In summing up his study of the spectra, Millman (1932: 140) concluded that, "... we find in them when viewed as a whole just about what we would expect from a consideration of ... the average constitution of meteorites." This reference to meteorites is interesting given that some meteor showers were known to be associated with specific comets. Yet comets never entered Millman's discussions (or, presumably, his thoughts). This is rather hard to explain.

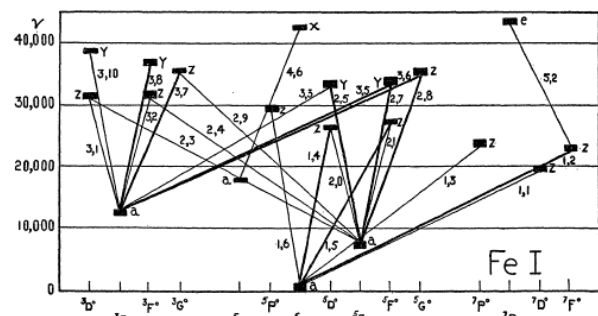

Figure 9: Grotian diagram showing the energy levels of iron that give rise to multiplets identified in meteor spectra (after Millman, 1932: 137).

## 7 THEORETICAL WORK ON METEORS AT HARVARD

In addition to his observational work, Peter Millman also attempted to determine the significance of his data by linking them to findings in other fields of astronomy and physics.

### 7.1 Atomic Physics, The Thermodynamic Environment, and Light Production of Meteors

Millman analyzed the multiplets (transitions between atomic energy levels) suggested by the iron lines (Figure 9) in order to gain information about the thermal environment of meteors. He found that almost all corresponded to shifts from one of the three lowest levels of the iron atoms. He then used five ratios of these multiplets between  $\lambda 4000$  and  $\lambda 4500$  (outside this range changes in plate sensitivity, small resolution, and poor definition made the spectral lines unsuitable for the task) to obtain the effective temperatures of the meteors. The resulting curve is shown in Figure 10, and from it Millman (1932: 146) concluded that, although "... the spectra showed very little detail and hence the determination of the excitation was very uncertain ...", it could still be stated that

In the four cases where microphotometer intensity measurements were made, the iron vapor was at states of

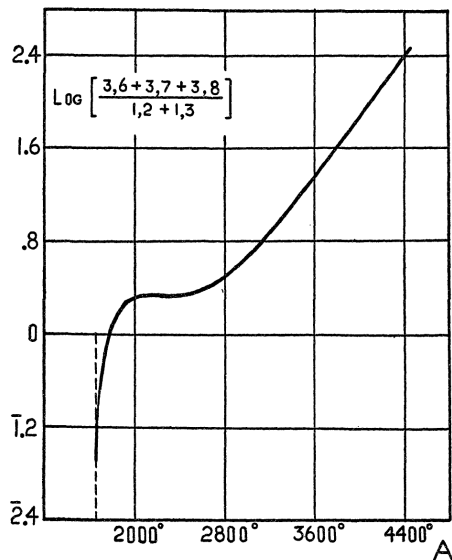

Figure 10: Graph comparing the excitation indicated in meteor spectra with the effective temperature of the surrounding meteor vapour (after Millman, 1932: 143).

excitation corresponding to furnace temperatures ranging from 1680 degrees to 2800 degrees absolute. In the spectra where eye estimates of intensity were made, the iron vapor in two cases had the excitation corresponding to a minimum temperature of 3400 degrees absolute. (ibid.).

Although these estimates are considerably below today's calculated values (Lewis, 1997), they mark the first serious attempt to use spectroscopy as a tool to analyze the thermal environment of a meteor.

Millman also used the spectra he had obtained to consider the source of meteor luminosity, something which was an open question at the time. He found that his work generally supported the theory of Ernst Öpik, who claimed that a meteor's light arose from a coma that formed from vapor released by the meteor as it descended through the atmosphere, either by impacts between air molecules and particles in the coma or from thermal radiation produced by particle impacts within the coma itself (Millman, 1935a). Millman pointed out that under these conditions the vapor would be in a low state of excitation and produce a

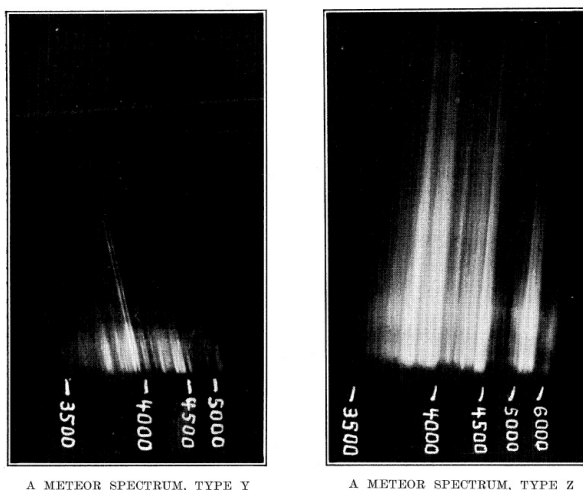

Figure 11: Millman's classification of meteor spectra. On the left is Type Y, with strong calcium H and K lines, and on the right Type Z, which is dominated by iron (after Millman, 1936b: 385).

spectrum dominated by emission lines coming from the lowest atomic levels. Lines from various ionized states, especially those arising from the first ionized state of easily ionized elements would also be expected. Millman found that these predictions were in broad agreement with his observations.

## 7.2 Meteoric Bursts, Spectral Classification and the Nature of the Atmosphere

Millman had not forgotten that one of the initial justifications Shapley had offered for the study of meteors was that it would reveal information about the upper atmosphere. In line with this, he considered the question of the cause of meteor bursts such as those described above in connection with Spectrum XXIV. After considering several earlier suggestions for the production of meteor bursts, including the gradual heating of the core and its splitting, he concluded that, "It is probably incorrect ... to take any one cause as the origin of all bursts in meteor trails." (Millman, 1935a: 176). He then offered his own suggestion:

We already know, from a study of the motion of meteor trains, that considerable turbulence exists in the atmosphere at great heights, and it is quite possible that the physical properties of the air in these regions may be less uniform than has hitherto been supposed. (ibid.).

Millman also designed a classification scheme for spectra which he hypothesized had a connection with atmospheric conditions. He was able to divide his spectra (with the exception of Spectrum III) into two types, Type Y, in which the most prominent spectral feature was the H and K lines of ionized calcium, and Type Z, in which ionized calcium lines were absent and the spectrum was dominated by iron lines (Figure 11). He then noted a correlation between the spectral type and altitude for the eight meteors whose heights had been determined. He found that the five meteors which appeared above 80 km were all Type Y, while the three below that altitude were each Type Z (Figure 12), and he remarked: "Though the observational evidence for this correlation is not large, it seems unlikely that it appears purely by chance." (Millman, 1935a: 171).

Millman rejected the obvious hypothesis that the Type Z spectra, with their predominance of iron spectral lines, represented iron meteorites (which lacked significant amounts of calcium), while the Type Y spectra corresponded to stony meteorites, which had a significantly greater calcium content. He pointed out that while Type Z spectra represented 64% of the first fourteen sporadic meteors photographed, iron meteorites made up only 5.4% of the total meteorites then known. "Type Z would seem to be of too frequent occurrence to be produced by iron meteorites." (Millman, 1935a: 171). Secondly, he noted that elements not commonly found in iron meteorites had been identified in Type Z meteor spectra.

Instead, Millman (1935a: 171-172) considered the possibility that the difference in the two types of spectra related to the atmospheric conditions under which the luminosity was being produced, rather than the compositions of the meteoroids themselves:

We find that the average height of the lower ionized layer, the maximum intensity of the aurora, noctilucent clouds, persistent meteor trains, and the greatest number of meteors all occur in the same region of the earth's

upper atmosphere, that between altitudes of 80 and 120 kilometers. This concurrence of phenomena should be regarded as significant. It is highly probable that the ionized condition at this height has a definite bearing on meteoric problems, a supposition which is certainly not weakened by the fact that spectra of Type Y seem to occur in and above the ionized layer whereas those of Type Z are below it.

**8 CONCLUDING REMARKS**

When Peter Millman began his Ph.D. studies at Harvard in 1931 he had no prior interest in meteors, let alone meteor spectra (Millman, 1963: 119). Rather meteor spectroscopy was assigned to him by Shapley. Yet it is obvious that Millman made an excellent fist of the task at hand: when he began his research, meteor science was a relatively insignificant branch of astronomy that relied almost entirely upon visual observations, and meteor spectroscopy was virtually non-existent. By the time he completed his Ph.D.—just two years later—Millman had begun to transform meteor spectroscopy from an astronomical afterthought into a systematic scientific field with an established methodology. Through his personal efforts in this period, 15 meteor spectra were recorded (Table 3), adding to only 9 previously in existence and thereby increasing the available data-bank by 167%. In the words of Ian Halliday (1994: 214):

Although some sporadic attention had been paid to the spectra of meteors early in this century, it was Millman’s research that established the fundamentals.

Moreover, in a relatively short period of time, Millman acquired what can only be described as a passion for meteor spectra if we are to believe the following admission that he included in a paper published in 1936:

There is no branch of astronomical photography that has a greater appeal to the sporting instinct than the photography of meteor spectra. This is because no one can predict when, or in what part of the sky, a bright meteor will appear, and when it does appear the whole phenomenon rarely lasts longer than two or three seconds. A program of meteor photography thus resolves itself into something very much like a fishing expedition, where the observer sets up a camera instead

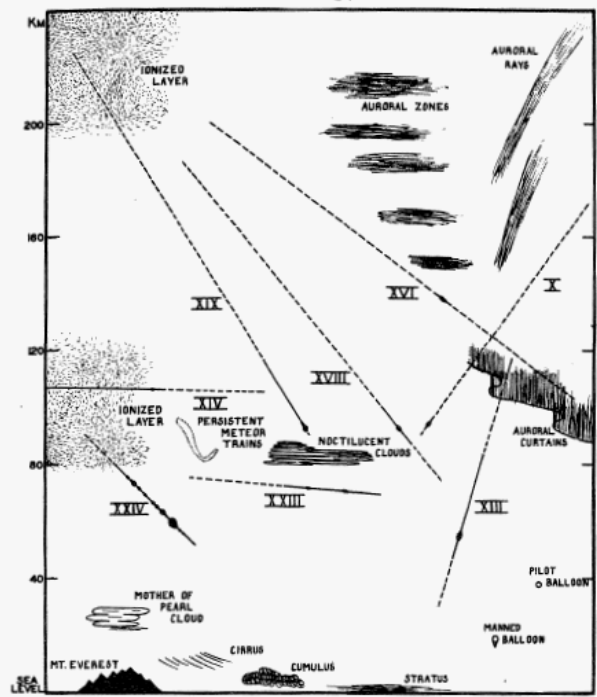

Figure 12: Diagram showing the heights of the meteors that produced the spectra examined by Millman (Roman numerals). There is a correlation between spectral category and the height at which the meteor appeared in the atmosphere (after Millman, 1935a: 155).

of throwing out a line and then leaves the shutter open, hoping that a bright meteor will cross that part of the sky towards which the camera is directed. The thrill of securing a particularly fine meteor spectrum is also closely akin to the elation experienced in landing a fish of record weight. (Millman, 1936b: 384).

After completing his work at Harvard in 1933, Millman returned to Canada to accept an appointment as a lecturer at the University of Toronto and astronomer at the affiliated David Dunlap Observatory. Although he continued to study meteor spectra throughout his career in Canada (e.g. see Millman, 1968; Millman et al., 1973), Millman expanded his portfolio considerably, including regular photographic observations, vis-

Table 3: Details of the fifteen meteor spectra recorded during the Harvard observing program, 1931-1933 (adapted from Millman, 1935a).

Spectrum	Date	Equipment	Associated shower	Plates Used	Lines in Spectrum
Camera A Blue Hill MA					
IX	15 Dec. 1931	Lens: Voigtlander Skopar, 30 mm aperture, 135 mm focal length, 4.5 aperture ratio Prism: 30° Average dispersion: H <sub>β</sub> -H <sub>γ</sub> 450 au/mm	Geminid	Cramer Hi-Speed	42
Camera B Ft. Worth TX					
XX	16 Nov. 1932	Lens: Xenar Schneider, 50 mm aperture, 175 mm focal length, 3.5 aperture ratio Prism: 20° Average dispersion: H <sub>β</sub> -H <sub>γ</sub> 900 au/mm	Leonid	?	9
Camera C Blue Hill MA					
X	12 Dec. 1931	Lens: Zeiss Tessar, 61 mm aperture, 165 mm focal length, 2.7 aperture ratio Prism: 15° Average dispersion: H <sub>β</sub> -H <sub>γ</sub> 1050 au/mm	Geminid	Cramer Hi-Speed	7
Camera K Oak Ridge MA					
XV	16 Nov. 1932	Lens: Moia Helimar Series I, 37 mm aperture, 165 mm focal length, 4.5 aperture ratio Prism: 35°, crown Average dispersion: H <sub>β</sub> -H <sub>γ</sub> 470 au/mm	Leonid	Cramer Iso Presto	12
XVI	16 Nov. 1932		Leonid	Cramer Hi-Speed	9
XIX	16 Nov. 1932		Leonid	Cramer Hi-Speed	12

Camera LT			Oak Ridge MA		
XVII	16 Nov. 1932	Lens: Zeiss Tessar IC, 56 mm aperture, 250 mm focal length, 4.5 aperture ratio Prism: 30°, flint Average dispersion: H <sub>β</sub> -H <sub>γ</sub> 260 au/mm	Leonid	Cramer Iso Presto	12
XVIII	16 Nov. 1932		Leonid	Cramer Iso Presto	7
Camera T			Flagstaff AZ		
XIII	26 May 1932	Lens: Zeiss Tessar, 61 mm aperture, 165 mm focal length, 2.7 aperture ratio (often at 3.5) Prism: 22°, crown Average dispersion: H <sub>β</sub> -H <sub>γ</sub> 500 au/mm	--	Cramer Iso Presto	28
XXII	17 Nov. 1932		Leonid	Cramer Iso Presto	12
XXIII	22 Feb. 1933		--	Cramer Iso Presto	8
Camera U			Flagstaff AZ		
XII	29 Apr. 1932	Lens: Boyer Saphir, 33 mm aperture, 150 mm focal length, 4.5 aperture ratio Prism: 35°, Hilger, flint Average dispersion: H <sub>β</sub> -H <sub>γ</sub> 410 au/mm	--	Cramer Iso Presto	24
XIV	27 May 1932		--	Cramer Iso Presto	42
XXI	17 Nov. 1932		Leonid	Cramer Iso Presto	14
XXIV	26 Feb. 1933		--	Cramer Iso Presto	64

ual observations (made mainly by his 'army') and radar observations of meteors; he also carried out considerable research on meteorites (see Jarrell, 2009). Mainly through his efforts and commitment, and by serving as a catalyst for others, Millman turned Canada into one of the world's leading nations involved in meteor astronomy and meteoritics (see Russell, 1991). Yet, until Z. Ceplecka, A.F. Cook, and J.A. Russell began working in the field in the late 1940s and during the 1950s, few astronomers world-wide acquired Millman's passion for meteor spectra, and it largely remained his 'domain' right up until his retirement from active research only weeks before his death in 1990.

When he began studying meteor spectra in 1931 Millman's aim was to learn more about the properties of the associated meteoroids and to use their passage through the Earth's atmosphere to investigate certain properties of the ionosphere. By the time he completed his life's work, he had succeeded admirably on both counts. Meanwhile, the bipartite scheme involving Y and Z spectra that he developed in 1935 largely stood the test of time. Nearly thirty years later he wrote:

A study of all available data has indicated that this original classification scheme is still useful ... [though it needs to be] revised slightly to adjust it to the pan-chromatic emulsions now generally used. (Millman, 1963: 121).

Although the work of this pioneering Canadian astronomer may be little remembered today, it is rarely that a researcher can legitimately be said to have laid the foundations for an original method of studying the heavens. Peter Mackenzie Millman was one such researcher, and we salute his important contribution to meteor astronomy.

## 9 NOTES

1. This table actually contains nine entries, for in early 1932 Miss L.L. Hodgdon found a photograph of a meteor spectrum on a 1913 plate housed in the archives of the Harvard College Observatory. Millman (1934b) named this Spectrum XI, since it was 'discovered' after the two Blue Hill meteor spectra were photographed.
2. This meteor spectrum was actually photographed on the morning of 15 December and is entered under this date rather than 14 December by Millman in his later lists of meteor spectra (e.g. see Millman, 1934b).

## 10 ACKNOWLEDGEMENTS

Grateful acknowledgement is given to the many people who assisted during the researching of this

paper, including: Alex Hons, Dr Andrew Walsh and Associate-Professor Graeme White from James Cook University; Dr Ralph Chou from the Royal Astronomical Society of Canada for direction in finding resources; Professor David Hughes for kindly supplying references and for reading and commenting on the manuscript; Professor Richard Jarrell from York University, Toronto, for sharing his research on Millman's Canadian observing program; Jacqueline Radigan and Brian Zarudny for proof-reading and support; staff from the Gerstein Library of the University of Toronto and those who maintain the NASA ADS website for provision of resources; and finally, Peter Millman, Ian Halliday and B.A. MacIntosh from the McCormick Museum for providing illustrations.

Above all, our deepest appreciation must be extended to the Millman family: Cynthia Floyd Millman, for sharing her memories of her father; Rowland Floyd for his extraordinary efforts in arranging contacts with the children of his father-in-law; and Barry Millman for opening his home and his memories and generously sharing the records of his father. Without their assistance, this paper would have missed a great deal of the spirit of Peter Millman's pioneering years.

## 11 REFERENCES

- Beech, M., 1992. The makings of meteor astronomy: Part I. *WNG, the Journal of the IMO*, 20, 218-219.
- Beech, M., 1995. The makings of meteor astronomy: Part X. *WNG, the Journal of the IMO*, 23, 135-140.
- Chambers, G.F., 1910. *The Story of Comets Simply Told for General Readers*. Oxford, Clarendon Press.
- Crook, B., 1989. Strong medicine – patient's love for young nurse leads to 58 years of marriage. *The Ottawa Citizen*, 7 May.
- Halliday, I., 1991. Peter Mackenzie Millman, 1906-1990. *Journal of the Royal Astronomical Society of Canada*, 85, 67-78.
- Halliday, I., 1994. Peter Mackenzie Millman, 1906-1990. *Transactions of the Royal Society of Canada*, 5, 212-214.
- Hearnshaw, J.B., 1986. *The Analysis of Starlight. One Hundred and Fifty Years of Astronomical Spectroscopy*. Cambridge, Cambridge University Press.
- Hoffleit, D., 1999. Canadian astronomers who earned the Ph.D. at Harvard during the Shapley era. *Journal of the Royal Astronomical Society of Canada*, 93, 262-271.
- Hogg, H.S., 1990. Peter Mackenzie Millman, 1906-1990. *Cassiopeia*, 69, 20-21.
- Hughes, D.W., 1982. The history of meteors and meteor showers. *Vistas in Astronomy*, 26, 325-345.
- Hughes, D.W., 1990. Meteors and meteor showers: an historical perspective 1686-1950. In Roche, J. (ed.). *Physicists Look Back*. Bristol, Adam Hilger. Pp. 261-305.
- Jarrell, R.A., 1988. *The Cold Light of Dawn: A History of Canadian Astronomy*. Toronto, University of Toronto

- Press.
- Jarrell, R.A., 2009. Canadian meteor science: the first phase, 1933-1990. *Journal of Astronomical History and Heritage*, 12, 224-234.
- Lankford, J., 1984. The impact of photography on astronomy. In Gingerich, O. (ed.). *The General History of Astronomy. Volume 4. Astrophysics and Twentieth-Century Astronomy to 1950: Part A*. Cambridge, Cambridge University Press. Pp. 16-39.
- Levy, D.H., 2001. *Starry Night: Astronomers and Poets Read the Sky*. Amherst, Prometheus Books.
- Lewis, J.S., 1997. *Physics and Chemistry of the Solar System*. San Diego, Academic Press.
- Lovell, A.C.B., 1954. *Meteor Astronomy*. Oxford, Clarendon Press.
- McCormick Museum, University of Virginia website: <http://www.astro.virginia.edu/~rjp0i/museum/gaertner1.html>
- Millman, P.M., n.d.. Curriculum Vitae. Millman Family records.
- Millman, P.M., 1926. Observing Mars in Japan. *Journal of the Royal Astronomical Society of Canada*, 20, 198-200.
- Millman, P.M., 1928a. Orbit of the spectroscopic binary H.R. 7200. *Journal of the Royal Astronomical Society of Canada*, 22, 143-144.
- Millman, P.M., 1928b. A mirage seen near Victoria, B.C. *Journal of the Royal Astronomical Society of Canada*, 22, 94.
- Millman, P.M., 1929. The quality of the light of the eclipsed Moon. *Journal of the Royal Astronomical Society of Canada*, 23, 201-207.
- Millman, P.M., 1932. An analysis of meteor spectra. *Annals of the Harvard College Observatory*, 82, 113-147.
- Millman, P.M., 1933a. Amateur meteor photography. *Popular Astronomy*, 41, 298-305.
- Millman, P.M., 1933b. Note on meteor spectrum photography in 1932. *Bulletin of the Harvard College Observatory*, 891, 6-8.
- Millman, P.M., 1933c. Spectrum of a fireball, February 26, 1933. *Journal of the Royal Astronomical Society of Canada*, 27, 353-354.
- Millman, P.M., 1933d. The spectra of meteors. *Journal of the Royal Astronomical Society of Canada*, 27, 150-154.
- Millman, P.M., 1934a. Meteor News. *Journal of the Royal Astronomical Society of Canada*, 28, 35-36.
- Millman, P.M., 1934b. Meteor News. *Journal of the Royal Astronomical Society of Canada*, 28, 175-179.
- Millman, P.M., 1934c. Meteor News. *Journal of the Royal Astronomical Society of Canada*, 28, 279-281.
- Millman, P.M., 1935a. An analysis of meteor spectra: second paper. *Annals of the Harvard College Observatory*, 82, 149-177.
- Millman, P.M., 1935b. Meteor News. *Journal of the Royal Astronomical Society of Canada*, 29, 115-117.
- Millman, P.M., 1936a. Meteor News. *Journal of the Royal Astronomical Society of Canada*, 30: 101-104.
- Millman, P.M., 1936b. Photography of meteor spectra. *The Scientific Monthly*, 42: 384-386.
- Millman, P.M., 1937. Meteor photography. *Journal of the Royal Astronomical Society of Canada*, 31, 295-310.
- Millman, P.M., 1963. A general survey of meteor spectra. *Smithsonian Contributions to Astrophysics*, 7, 119-127.
- Millman, P.M., 1968. A brief survey of upper air spectra. In Kresak, L., and Millman, P.M. (eds.). *Physics and Dynamics of Meteors*. Dordrecht, Reidel. Pp. 84-90.
- Millman, P.M., and Hoffleit D., 1937. A study of meteor photographs taken through a rotating shutter. *Annals of the Harvard College Observatory*, 105: 601-621.
- Millman, P.M., Cook, A.F., and Hemenway, C.F., 1973. Image orthicon spectra of Geminids in 1969. In Millman, P.M., Cook, A.F., and Hemenway, C.F., (eds.). *Evolutionary and Physical Properties of Meteoroids*. Washington, NASA (SP-319), 147-151.
- Norman, D., 1938. The development of astronomical photography. *Osiris*, 5, 560-594.
- Olivier, C.P., 1925. *Meteors*. Baltimore, Williams and Wilkins.
- Olivier, C.P., 1930. *Comets*. Baltimore, Williams and Wilkins.
- Russell, J.A., 1991. Memorial for Peter Mackenzie Millman. *Meteoritics*, 26, 173.
- Shapley H., 1928. Research notes from the Harvard Observatory. *Science*, 68, 100-102.
- Shapley, H., 1932. The current photographic programs of the Harvard Observatory. Abstract of a presentation reported in Conference on Astrophotographic Problems. *Science*, 75, 609-611.
- Shapley, H., Öpik, E.J., and Boothroyd, S.J., 1932. The Arizona expedition for the study of meteors. *Proceedings of the National Academy of Sciences*, 18, 16-23.
- Young, C.A., 1888. *Text-book of General Astronomy for Colleges and Scientific Schools*. Boston, Ginn.

Steven Tors teaches Earth & Space Science at Agincourt Collegiate Institute in Toronto, Canada. He studied science, history and education at the University of Toronto, and has a particular interest in the history of astronomy. In 2006 he completed a part-time, internet-based Master of Astronomy through the Centre for Astronomy at James Cook University in Townsville, Australia. As part of this degree he carried out historical research on Peter Millman's investigation of meteor spectra.

Wayne Orchiston is an Associate-Professor in the Centre for Astronomy at James Cook University, and has wide-ranging research interests, including the history of cometary and meteor astronomy. He has published extensively, including a series of papers on Australian and New Zealand cometary astronomy. A former Secretary of IAU Commission 41 (History of Astronomy), Wayne serves on the committees of the IAU Working Groups on Transits of Venus and Historic Radio Astronomy.