



# VU Research Portal

## Modelling network synergy: static and dynamic aspect

Nijkamp, Peter; Reggiani, Aura

1995

### **document version**

Publisher's PDF, also known as Version of record

[Link to publication in VU Research Portal](#)

### **citation for published version (APA)**

Nijkamp, P., & Reggiani, A. (1995). *Modelling network synergy: static and dynamic aspect*. (Research Memorandum; No. 1995-49). Faculty of Economics and Business Administration, Vrije Universiteit Amsterdam.

### **General rights**

Copyright and moral rights for the publications made accessible in the public portal are retained by the authors and/or other copyright owners and it is a condition of accessing publications that users recognise and abide by the legal requirements associated with these rights.

- Users may download and print one copy of any publication from the public portal for the purpose of private study or research.
- You may not further distribute the material or use it for any profit-making activity or commercial gain
- You may freely distribute the URL identifying the publication in the public portal ?

### **Take down policy**

If you believe that this document breaches copyright please contact us providing details, and we will remove access to the work immediately and investigate your claim.

### **E-mail address:**

[vuresearchportal.ub@vu.nl](mailto:vuresearchportal.ub@vu.nl)

05348

1995 Serie Research Memoranda

049

MODELLING NETWORK SYNERGY: STATIC AND DYNAMIC ASPECT

Peter Nijkamp  
Aura Reggiani

Research Memorandum 1995-49



**MODELLING NETWORK SYNERGY: STATIC AND DYNAMIC ASPECT**

**Peter Nijkamp  
Aura Reggiani**

**Research Memorandum 1995 - 49**

## **MODELLING NETWORK SYNERGY: STATIC AND DYNAMIC ASPECTS**

**Peter Nijkamp**  
Department of Economics  
Free University  
De Boelelaan 1105  
1081 HV Amsterdam  
The Netherlands

**Aura Reggiani**  
Department of Economics  
University of Bologna  
Piazza Scaravilli, 2  
40126 Bologna  
Italy

## Abstract

The present paper aims at developing a new research approach based on the synergy concept as a driving force in network analysis and modelling. Starting from some introductory reflections identifying the role of network synergy in regional development and transportation science, the paper aims at giving a new interpretation of synergy effects in a network by focussing the attention on three dimensions of economic network analysis, based on the related (network) production functions. These dimensions or levels are: network links, uni-modal networks and multi-modal networks. In the paper, first a static economic analysis is carried out with particular attention to the role played by connectivity and 'diversity' among actors/segments/layers in a network. Next, the restructuring effects of either complementarity or competition between different links and modalities will be investigated by looking at the dynamic aspects of network performance by revisiting and investigating concepts from evolutionary ecology in connection with resilience and sustainability issues.



## 1. **The Relevance of Network Synergy**

It is increasingly recognized that many economic and spatial transactions tend to reflect nowadays an organized form based on network configurations and network processes. Networks seem to become simultaneous vehicles for transportation and communication behaviour (Capineri, 1993). Networks exhibit a structure of **organized point-to-point connections** via segments or links between nodal cores of a spatial interaction system. They are instrumental to various logistic tasks to be fulfilled by actors or users. Thus, networks do not only derive their importance from the physical structure itself, or its ramifications, but also from the **functions** they provide by connecting nodal points in the underlying structure with a view on efficient operations via organized linkage patterns (see also Dupuy, 1993). On the other hand, the 'shape' of the structure - or its morphology (visible or invisible) - is relevant for the network function<sup>1</sup>. Consequently, the notion of a network has to be interpreted from the relevance of discontinuity of points - in contrast to the spatial contiguity of closed forms - and heterogeneity of points (see again Dupuy, 1993); in other words, the **morphology** - in relation to function - is an essential property of the network. It is thus clear that the basic principle of a network is connectivity. "Connectivity - which may be quantified by various indices - indicates the existence of multiple relationships, of alternative paths which **reinforce** the 'interconnection' of a network" (Dupuy, 1993, p. 43). Connectivity - given the complex, dynamic, often non-linear character of the relationships - determines the nature of networks as "space-time complex systems" (see Reggiani and Nijkamp, 1995a), with a view on creating **synergy**<sup>2</sup>, leading to higher economic benefits for all actors involved. Clearly, in dynamic spatial interactions the **evolution of the value added** among

---

<sup>1</sup> 'The set of locations forms a heterogeneous whole and from its heterogeneity arises the need for the links and the relationships provided by the network' (Dupuy, 1993, p.42).

<sup>2</sup> Synergy is also a particular case of the more general phenomenon of synergetics, which is referring to morphological changes in complex dynamic systems (Haken, 1992).

the network elements has to be taken into account as well. In this context, **actor dependency** through physical and non-physical interaction/connectivity (see Kamann and Nijkamp, 1991) definitely plays a significant role.

Formally, one may define **synergy** in a network as a situation of (positive) user externalities through (spatial) interactions - in the form of transportation or communication - between various operators (actors, users) of a network ('interoperability'), as a result of an efficient interconnectivity of the network concerned (in terms of connectivity between nodes, accessibility of centres, or intermodality) which generates value added from scale advantages - and hence increasing marginal benefits (or decreasing marginal costs) - for all users involved. This means that synergy is a user externality caused by a favourable supply - based architecture or design of a network (cf. Frankhauser, 1994).

Starting from the above reflections, the present paper aims at developing a novel research approach based on the **synergy concept as a driving force for network performance**. For this purpose some simple and illustrative (multi-layer) economic models will be developed which display two levels of analysis ranging from micro to macro. Also different degrees of complexity of networks will be discussed by emphasizing the " 'inherent bipolarity' expressed by the internal logic of each network, which distinguishes the single network from the others, and by the external logic which links the network to the reference systems" (Capineri, 1993, p. 13). We will first present some background observations in the next section.

## 2. **User Benefits from Network Synergy**

As mentioned in Section 1, networks offer efficient operations for their users through synergy. In this section we will develop a new theoretical framework for network synergy analysis. Synergy in networks will be investigated in our paper from three complementary perspectives, viz. a **network link** perspective, a **uni-modal** network perspective and a **multi-modal** network perspective. The methodology adopted is essentially based on the standard micro-economic theory of production which we will use as a general analysis framework in

relation to the network concepts referred to in the previous section.

The user benefits  $Y$  of a network are based on the fact that the productive capacity  $P$  (or potential) of a network is essentially governed by two background factors:

- (i) **network coverage (R)**; this means that the significance of an individual link in a network is higher as the network has a broader action radius (in terms of places to be reached, number of subscribers connected). This concept is essentially an investment-oriented network factor increasing the productivity of a link, which is essentially based on **network externalities**, where increasing marginal benefits may be expected if the network capacity increases with direct benefits to the user but without extra payments by the beneficiary (see Capello, 1994).
- (ii) **network connectivity (C)**; this refers to the quality of connections in a given network as a result of network synergy and is a result of the morphology of a network (including multi-modal connections).

The above observations clarify that, the productive capacity or potential ( $P_i$ ) for each link  $i$  in a network is determined by the above mentioned two background factors, so that:

$$P_i = f_i(R, C), \tag{2.1}$$

where  $P_i$  indicates the maximum production possibility generated as a result of the total network configuration for link  $i$ , as allowed for by the presence of  $R$  and  $C$ . Each network has an actual economic performance (in terms of benefits, utility, productivity or value added) as a result of the operations of all users. The productive potential  $P_i$  forms the production possibility frontier for the output  $Y_i$  (or benefits) of a network. Then we may now plausibly assume that the economic performance  $Y_i$  of an individual network link  $i$  may take (for example, by considering the network coverage constant) the following form (see Figure 1).

Figure 1. About here



By considering the individual performance of a link  $i$  as a function of the total network potential, it is noticeable that we may take for granted the existence of two thresholds  $(Y_i^{\min}, Y_i^{\max})$  which reflect the range of significance of  $Y_i$ . In other words, a network link has a certain potential (in terms of its overall performance), which is determined by both **supply** and **demand** elements: supply creates the conditions (initial conditions, capacity conditions) under which demand will operate. Thus, there is a **maximum limit** to the performance of link  $i$  to which an optimal network potential  $P_i^{\max}$  corresponds. Below  $P_i^{\max}$ , network externalities and synergies lead to an exponential or logistic growth for the performance curve of link  $i$ . Clearly, beyond point  $(Y_i^{\max}, P_i^{\max})$  we have a **decreasing marginal performance** to which a **weaker synergy** corresponds, leading ultimately to negative synergy.

Next, it is also clear that in order to generate a significant network performance leading to a **positive synergy** (as a consequence of scale and overhead advantages), a minimum level of network externalities and quality is also necessary (otherwise transaction costs may have to be shared by too low a number of actors). Clearly, a minimum performance  $Y_i^{\min}$  corresponds to this threshold value. As a consequence, beyond point  $(Y_i^{\min}, P_i^{\min})$  we have an **increasing performance** or a **positive synergy** up to the point  $(Y_i^{\max}, P_i^{\max})$ .

The previous remarks mean that we can formally test for the existence of **synergy** on a link by investigating the **marginal (positive or negative)** performance of a given link (see again Figure 1). Clearly, we should ultimately not only look at the performance of one link, but at that of all links. In such a case, positive externalities may occur (e.g., in a telecommunication network), but also negative externalities may emerge (e.g., in case of congestion).

If we now assume, for the relevant range, a continuity property for the variable  $Y_i$  including a saturation effect, then in a dynamic setting this may lead to an S-shaped (symmetric or non-symmetric), curve for  $Y_i$ , with a turning point  $Y_i^*$  expressing that the growth in the performance of  $Y_i$  is at its peak (obviously,  $Y_i^{\min}$  expresses here the 'take-off' of the network link performance). Thus, the range  $(Y_i^{\min}, Y_i^*)$  denotes increasing synergy, while the range  $(Y_i^*, Y_i^{\max})$

indicates a declining (although positive) synergy. The above relations are in a concise way illustrated in Table 1.

Table 1. About here.

Clearly, the maximum capacity levels are not constant, but may depend on new logistics or technological progress. In many evolutionary economic analyses a critical role for a rise in systemic performance is indeed played by technological change. It is interesting to note that in the modern endogenous growth literature technological progress is always able to find 'new' capacity levels for the performance of a system (see Prigogine, 1976).

We will now analyze in more detail network performance based on the above micro-economic production theory. We will conceive of a network (and its links) as a productive system which serves the interests of individual users. In this context we are interested in the measurement of the **productivity performance** of networks as an indicator for their efficiency (both over time and in comparison to other systems) (see, e.g., Dodgson, 1985 and Lazarus, 1982). We may consider at the network link level the performance  $Y_i$  of link  $i$ . We will assume here that this performance in the network can be described by the following production function:

$$Y_i = f(P_i, F_i) \tag{2.2}$$

where  $P_i$  stands for the aggregate potential of link  $i$  as determined by coverage and connectivity input factors), and where  $F_i$  represents all other relevant factors of production, such as capital or labour. Formulation (2.2) shows the maximum output obtainable for network link  $i$  from any given combination of the inputs, given the state of (also technological) knowledge at time  $t$ .

Usually, inputs are assumed to be substitutable, so that production function (2.2) may yield a smooth isoquant showing alternative combinations of inputs which would produce a given level of network output (see, e.g., Dodgson, 1985 and Varian, 1978). In this context, one of the most popular functional forms

for (2.2), used in many studies on producer's behaviour, is the Cobb-Douglas production function, which is homogeneous and separable; it permits constant, increasing, or decreasing returns to scale depending on whether the sum of the parameters  $\alpha$  and  $\beta$  is equal to, greater than, or less than unity. But of course, alternative specifications are equally well possible.

It is well known from the economics literature (see, e.g., Varian, 1978) that production technology needs to be represented by both a production function and its associated cost function. In the framework of a network analysis, we may assume the following cost function  $K_i$  for link  $i$ :

$$K_i = c_{P_i} P_i + c_{F_i} F_i \quad (2.3)$$

where  $c_{P_i}$  indicates the average cost associated with the potential  $P_i$  of link  $i$  and  $c_{F_i}$  the average cost of all other input factors.

In the presence of network externalities and synergetics, we may assume that the unit network capital costs  $c_{P_i}$  on link  $i$  are not given in advance, but are a function of the performance (e.g., network use) of other actors all over the network. This would mean:

$$c_{P_i} = g_i(P_j) \quad (2.4)$$

In that case we get a non-linear expression for the cost function  $K_i$ , since the cost  $K_i$  may now include direct costs as well as social (external) costs (like congestion cost, environmental costs, etc.). In this context also a multi-cost function might be used, such as the translog or transcendental logarithmic cost function (see e.g., Dodgson, 1985). This cost function may then be interpreted as a general 'damage' function, offering insight into the 'sustainability' of the network. It should also be noted that the network properties described in Section 1 are implicitly embedded in formulations (2.3) and (2.4).

After the analysis of the behaviour of a network link, the next step is the analysis at the network level, i.e. the analysis of the network performance on the basis of multiple links. This means essentially the search for equilibrium in a network from an aggregate system's perspective. It is clear that in this case

connectivity among links plays the major 'synergy role'. Then we have to represent - at a meso level - the 'synergy effects' on the network performance, due to the connectivity between diverse links, or even modes in a multimodal network.

In a multiple link situation, the aggregate potential is equal to:

$$P = \sum_i P_i \quad (2.5)$$

with

$$P_i = f(R, C) \quad (2.6)$$

This means that  $P$  is a non-linear expression in all background factors  $R$  and  $C$ , which may be analytically hard to solve. The same applies now of course to also the user benefits in a multi-link network. If we generalize the previous findings to a multi-modal network, we would *mutatis mutandis* again find similar results (see Nijkamp and Reggiani, 1995). Thus, synergy generates a highly non-linear benefits expression for the network performance. In practice, this means that simulation experiments may have to be carried out in order to approximate the user benefits in a multi-link multi-modal. In our paper we will undertake such simulation experiments by assuming a dynamic evolutionary pattern of network synergy. This will be further discussed in the next section.

### 3. Towards Dynamic Network Synergy Models

In the previous parts of this paper we have addressed the issue of network synergy in a static context, taking a generalized production function approach as a frame of reference. It seems plausible however, that a dynamic framework may bring to light more interesting properties of the performance of a spatial network system.

In particular we can consider the following scheme (see Figure 2) where

the variables at hand are looped in a dynamic way.

Figure 2. About here

Figure 2 shows the dynamic setting of the static equations (2.1), (2.2) and (2.3). By considering feedback effects for equations (2.2) and (2.3), we may also assume that dynamic loops between the network potential  $P_t$  on the one hand and other efficiency factors  $F_t$  on the other hand are taking place via the associated cost function  $K_t$ , thus generating evolutionary (non-linear) pathways. The background of such feedback loops may be caused by cost minimizing strategies, through which endogenous growth is realized by adjusting the cost parameters in equation (2.3). Consequently, the analytical forms of the above dynamic take into account the dynamic feedback loops between  $P_t$  and  $F_t$  by considering various (non)linear impact expressions and may thus provide more insight into the resulting synergy  $S$  (emerging from the dynamics of  $P_t$  and  $Y_t$ ).

The dynamic feedback loops between  $P_t$  and  $F_t$  may however, exhibit a wide variety of dynamic behaviour. Given the non-linearity of these relationships it is very hard to derive analytical equilibrium properties for these equations. And therefore, we have to resort to simulation experiments trying to extrapolate some structural 'behavioural' patterns. The various types of dynamic loops - together with the related simulation experiments - will concisely be discussed here from the viewpoint of evolutionary system's ecology.

#### A. **Prey-predator Relationships between the Input Factors $P_t$ and $F_t$**

Here we may assume that the network potential  $P_t$  is the predator and the remaining efficiency factors  $F_t$  the prey. This would imply that the network potential  $P_t$  (measured in terms of coverage and connectivity input factors) increases with the remaining efficiency factors  $F_t$  while the latter show a negative impact (decrease) when the former increases.

The formal representation of the relevant equations <sup>3</sup> in Figure 2 is given in (3.1) where - for the sake of simplicity - we also assume a linear dynamic relationship in F and P for the network performance Y (leading to a constant synergy effect).

$$\begin{aligned}
 F_{t+1} &= F_t (a - bF_t - cP_t) \\
 P_{t+1} &= P_t (d - eP_t + fF_t) \\
 Y_{t+1} &= \alpha F_t + \beta P_t
 \end{aligned}
 \tag{3.1}$$

This situation could be plausible for example, in the case of efficient networks (with high synergy), like an efficient airline company, or the actual telephone-mobile network.

In the simulation experiment related to typology (3.1) we have considered the following parameter values:

$$\begin{aligned}
 a &= 2.7 & b &= 1 & c &= 0.5 \\
 d &= 2.6 & e &= 1 & f &= 0.5 \\
 \alpha &= 0.3 & \beta &= 0.5
 \end{aligned}$$

The results show - for all the variables F, P, Y - the onset of unstable behaviour in the short run followed by stable patterns in the long run (see Figure 3)

Figure 3. About here

#### B. Symbiosis Relationships Between the Impact Factors $P_t$ and $F_t$

In this case we assume a logistic growth where both input factors reinforce one another. The formal equations for such a symbiosis case are:

---

<sup>3</sup> The following dynamic equations are expressed discretely, given the discrete nature of the variables at hand (see, for further discussions on the topic of continuous/discrete - time models, Nijkamp and Reggiani, 1992, Reggiani and Nijkamp, 1995b, Thill and Wheeler, 1995).

$$\begin{aligned}
F_{t+1} &= F_t (a - bF_t + cP_t) \\
P_{t+1} &= P_t (d - eP_t + fF_t) \\
Y_{t+1} &= \alpha F_t + \beta P_t
\end{aligned}
\tag{3.2}$$

In this simulation experiment we have kept the same parameter values as in 3A. The result indicates a complete stable pattern for all the variables at hand by showing a **stabilizing effect** on the system (see Figure 4).

Figure 4. About here

**C. Prey-Predator/Symbiosis/Competing Relationships Between the Input Factors  $P_t$  and  $F_t$  with  $Y_t$  as Inclusive Factors**

This general case offers a wide spectrum of possibilities as illustrated subsequently.

**C.1 Prey-predator relationships between  $P_t$  and  $F_t$  by including the production function  $Y_t$  with predator/symbiosis effects.**

This first typology implies essentially that the two factor inputs can show a prey-predator relationship in a direct way, but a complementary relationship via again a prey-predator effect of the performance indicator  $Y_t$  in an indirect way. This may, for instance, happen if a high network performance has a positive impact on investments, while keeping a negative impact on the connectivity. This is, for example, the case of a high congested network. The formal specification of such a model is:

$$\begin{aligned}
F_{t+1} &= F_t (a - bF_t - cP_t + gY_t) \\
P_{t+1} &= P_t (d - eP_t + fF_t - hY_t) \\
Y_{t+1} &= \alpha F_t + \beta P_t
\end{aligned}
\tag{3.3}$$

The related simulation has been carried out by considering the following parameter values:

$$\begin{array}{llll}
a = 2.9 & b = 1 & c = 0.5 & g = 0.1 \\
d = 2.7 & e = 1 & f = 0.5 & h = 0.5 \\
\alpha = 0.3 & \beta = 0.5 & & 
\end{array}$$

from which an irregular pattern emerges (see Figure 5).

Figure 5. About here

It is interesting to note that if we consider in equation (3.3) a symbiosis effect given by the performance indicator  $Y_p$ , i.e.:

$$h = -0.5$$

we get again an irregular pattern/behaviour, although more 'compact' than the previous one (see Figure 6). This may, for instance, happen if a high network performance has a positive impact on investments in the two inputs (this is essentially an example of an endogenous growth theory for networks).

Figure 6. About here

## C.2 Competing relationships between $P_t$ and $F_t$ by including the production function $Y_t$ with predator/symbiosis effects

This case means that the rise in one input will lower the availability of the other input, while the impact of the production function is shown by means of predator or symbiosis effect. In the first situation the typology C.2 reads as follows:

$$\begin{array}{l}
F_{t+1} = F_t (a - bF_t - cP_t + gY_t) \\
P_{t+1} = P_t (d - eP_t - fF_t - hY_t) \\
Y_{t+1} = \alpha F_t + \beta P_t
\end{array} \tag{3.4}$$

leading to a cyclical/periodic behaviour as depicted in Figure 7.

Figure 7. About here



If we now consider - in equation (3.4) - the impact of the production function in a symbiotic way, by assuming for example:

$$h = 0.5$$

we can observe again a stabilizing effect (see Figure 8). This result corresponds to the second case of typology C.2.

Figure 8. About here

It is interesting to note that if we increase the carrying capacities of the input factors  $F_t$  and  $P_t$  by considering, for example:

$$a = 3.3 \quad d = 3.1$$

we obtain a complete cyclical behaviour in the case - for the system at hand - of a predator relationship in  $Y_t$  (see Figure 9), while for the case of symbiosis in  $Y_t$  we get again a stable pattern (see Figure 10).

Figure 9. About here

Figure 10. About here

### C.3 Symbiosis relationship between $P_t$ and $F_t$ by including the production function $Y_t$ with predator/symbiosis effects

In this third typology we consider the case in which the rise in one input will increase the availability of the other input, in integration with a predator/symbiosis relationship for the production function.

The typology for the first case reads then as follows:

$$\begin{aligned} F_{t+1} &= F_t (a - bF_t + cP_t + gY_t) \\ P_{t+1} &= P_t (d - eP_t + fF_t - hY_t) \\ Y_{t+1} &= \alpha F_t + \beta P_t \end{aligned} \tag{3.5}$$

leading again to a cyclical behaviour (Figure 11), which persists also in the second case (symbiosis in  $Y_t$ ; see Figure 12).

Figure 11. About here

Figure 12. About here

**D. Competitive Relationships Between the Input Factors  $P_t$  and  $F_t$**

This case means that the rise in one input will lower the availability of the other input. There are several formal specifications possible for such a substitution relationship.

**D1. Dynamic competition with a linear production function**

The formalisation of this model is as follows:

$$\begin{aligned} F_{t+1} &= F_t (a - bF_t - cP_t) \\ P_{t+1} &= P_t (d - eP_t - fF_t) \\ Y_{t+1} &= \alpha F_t + \beta P_t \end{aligned} \tag{3.6}$$

The simulation experiments show, in this case, a pattern behaviour dependent on the value of the carrying capacities.

Starting, for example, from the following parameter values:

$$\begin{array}{lll} a = 2.7 & b = 1.7 & c = 0.5 \\ d = 2.6 & e = 1.3 & f = 0.9 \\ \alpha = 2.3 & \beta = 2.5 & \end{array}$$

we observe a complete stable pattern for all the variables (see Figure 13).

Figure 13. About here

By increasing, then, the carrying capacities of  $F_t$  and  $P_t$  as follows:

$$a = 3.7 \quad d = 3.6$$

we observe a complete unstable behaviour (see Figure 14).

Figure 14. About here

It is then interesting to express the last equation of (3.6) by means of the

synergy specification. This will be developed in the following cases D2, D3, D4.

**D2. Dynamic competition with a logistic growth of relative network performance (via synergy productivity)**

This case leads to the following general specification for a network synergy function:

$$\begin{aligned} F_{t+1} &= F_t (a - bF_t - cP_t) \\ P_{t+1} &= P_t (d - eP_t - fF_t) \\ Y_{t+1} / P_{t+1} &= \lambda P_t (1 - P_t) \end{aligned} \tag{3.7}$$

Also in this case low values of the carrying capacities, like, for example:

$$a = 1.7 \quad d = 1.6$$

lead to a stable pattern, eventhough the growth rate of the logistic synergy function is rather high:

$$\lambda = 4.9$$

This stable behaviour, depicted in Figure 15, changes completely, by showing instability, as soon as we increase the carrying capacities to:

$$a = 3.7 \quad d = 3.6$$

It is interesting to note that the above unstable behaviour, illustrated in Figures 16 and 17, persists even for low values of the growth rate  $\lambda$ , like for example:

$$\lambda = 0.05$$

This last simulation experiment is shown in Figure 18.

Figure 15. About here

Figure 16. About here

Figure 17. About here

Figure 18. About here

The relevance of the carrying capacities in the typology D, expressing competi-

tion between the input factors, is also illustrated in Figure 19, where a negative growth rate in the logistic function has been taken into account; in particular we have assumed here:

$$\lambda = -0.5$$

The emerging result shows the 'robustness' of the competing relationships between  $F_t$  and  $P_t$ , even in their unstable 'corridors'.

Figure 19. About here

**D3. Dynamic competition with a linear growth of relative network performance (via synergy production)**

This is a special case of D2 and can be written as follows:

$$\begin{aligned} F_{t+1} &= F_t (a - bF_t - cP_t) \\ P_{t+1} &= P_t (d - eP_t - fF_t) \\ Y_{t+1} / P_{t+1} &= \lambda P_t \end{aligned} \tag{3.8}$$

Also in this case instability emerges for high values of the carrying capacities and growth rate of the synergy function:

$$a = 3.7 \quad b = 3.6 \quad \lambda = 3.9$$

This means that even the type of synergy function cannot influence (in our case stabilize) the pattern emerging from the competing relationships between the input factors (see Figure 20).

Figure 20. About here

**D4. Dynamic competition with the generalized logistic growth of relative network performance (via synergy productivity)**

This latter case is a fairly general one and can be described by the following equations:

$$\begin{aligned} F_{t+1} &= F_t (a - bF_t - cP_t) \\ P_{t+1} &= P_t (d - eP_t - fF_t) \\ Y_{t+1} / P_{t+1} &= \lambda P_t (1 - P_t) (1 - P_t / P_{t+1}) + Y_t / P_{t+1} \end{aligned} \tag{3.9}$$

This particular case is interesting since it shows a linear dynamic behaviour for the productivity function, while the input factors remain unstable (see Figure 21 for the value of  $\lambda=2.9$ , while keeping the other parameter unchanged). Consequently in this typology - case forecasting analyses - at least for the variable  $Y_t$  - could be undertaken.

Figure 21. About here

#### 4. Conclusion

Regarding the wide array of simulation possibilities and results on dynamic network synergy models, we will present here a few interesting conclusions and reflections.

First, it is noteworthy that in general symbiosis effects tend to stabilize a network system governed by synergy factors.

Next, it is also interesting to observe that, generally speaking, the resilience of network symbiosis tend to be rather low, which means that the system requires fairly low carrying capacities in order not to lose its robust character.

It is also remarkable that both the prey-predator and the competitive network systems are rather robust (i.e., the allowance for large domain of parameter values), although these systems can clearly produce cycles, irregularities or chaos for relatively high values of the systemic carrying capacity and growth rates of the system.

It should be added that thus far we did not pay attention to the morphological structure of the network, in terms of the configuration of links and networks. We may plausibly expect complex dynamic behaviour in case of dynamic interactions among links in networks, but of course these results will depend on the assumptions made on the above typology 3A-3D.

Finally, it is noteworthy that the concept of synergy - cast in the framework of a production function approach to network performance and complemented with dynamic feedbacks between input factors - plays a central role in

the dynamical behaviour of networks. Clearly, more research is needed in this field, in particular, the identification of synergy indicators in networks, the empirical assessment of synergy in a multi-nodal and multi-modal network and the formal analysis of equilibrium behaviour in a multi-actor network.

### **Acknowledgement.**

The present paper has been developed in the framework of the Italian CNR Project PFT2, Contract n° 94.01441.PF74

### **References**

Capello, R., Regional Economic Analysis and Telecommunications Network Externalities, Ph.D. Dissertation, Free University, Amsterdam, 1994.

Capineri, C., Italian Geography and Networks, Flux, 11, 1993, pp. 5-16.

Dodgson, J.S., A Survey of Recent Developments in the Measurements Rail Total Factor Productivity, International Railway Economics (K.J. Button and D.E. Pitfield, eds.), Gower, Aldershot, Hants, 1985, pp. 13-48.

Dupuy, G., Networks, Flux, 11, pp. 42-47.

Frankhauser, P., La Fractalité des Structures Urbaines, Anthropos/Economica, Paris, 1994.

Haken, H., Some Applications of Synergetics to the Study of Socio-Technical Systems, Journal of Scientific & Industrial Research, 51, 1992, pp. 147-150.

Kamann, D.J. and P. Nijkamp, Technogenesis, Technological Forecasting and Social Change, vol. 39, 1991, pp. 35-46.

Lazarus, P.E., Productivity and the Relationship between Railway Administrations and Governments, Rail International, 1982, pp. 51-57.

Nijkamp, P. and A. Reggiani, Interaction, Evolution and Chaos in Space, Springer Verlag, Berlin, 1992.

Nijkamp, P. and A. Reggiani, Multi-layer Synergy and Networks, Giornale degli Economisti, 1995 (forthcoming).

Prigogine, I., Order through Fluctuations: Self-Organization and Social System, Evolution and Consciousness (E. Jantsch and C.H. Waddington, eds.), Addison-Wesley, Reading, Mass., 1976.

Reggiani, A. and P. Nijkamp, Competition and Complexity in Spatially Connected Networks, System Dynamics Reviews, vol. 11, No. 1, 1995a, pp. 51-66.

Reggiani, A. and P. Nijkamp, Multi-layer Networks and Dynamic Transport Systems, Geographical Systems, vol. 2, 1995b, pp. 39-57.

Thill, J.-C. and A.K. Wheeler, On Chaos Continuous-Time and Discrete-Time Models of Spatial System Dynamics, Geographical Systems, vol. 2, 1995, pp. 121-130.

Varian, H.R., Microeconomic Analysis, Norton & Company, London/New York, 1978.

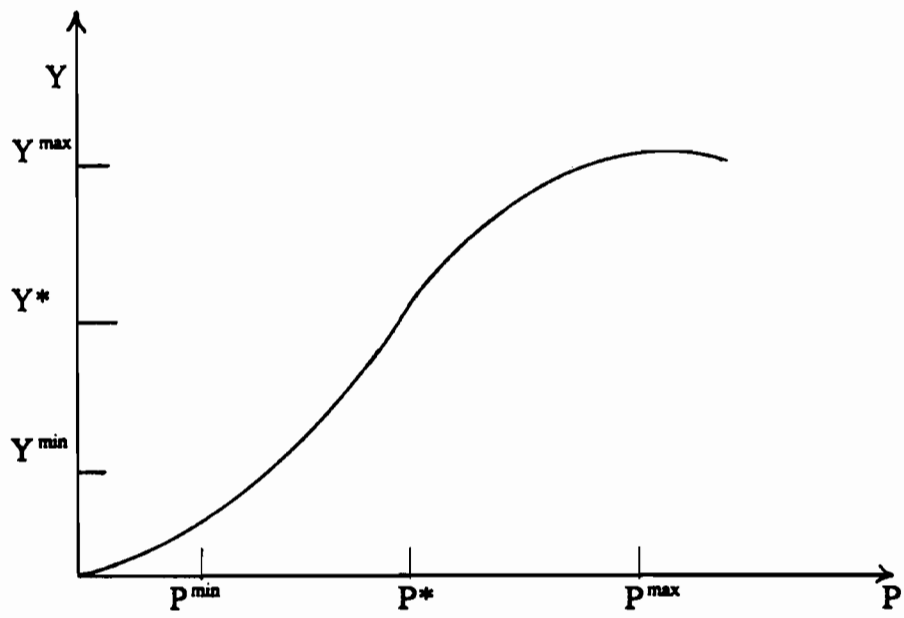

Figure 1. Performance, Actors and Synergy in a Network



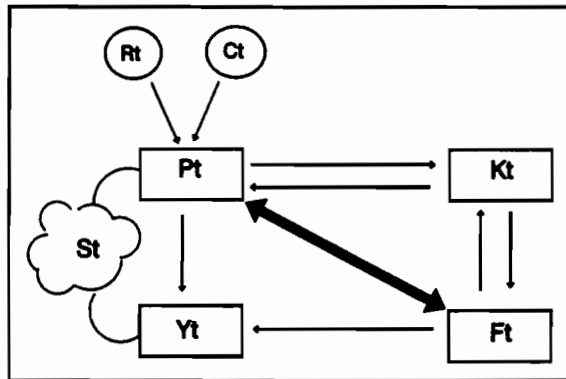

Figure 2. Dynamic Framework of the Network Performance

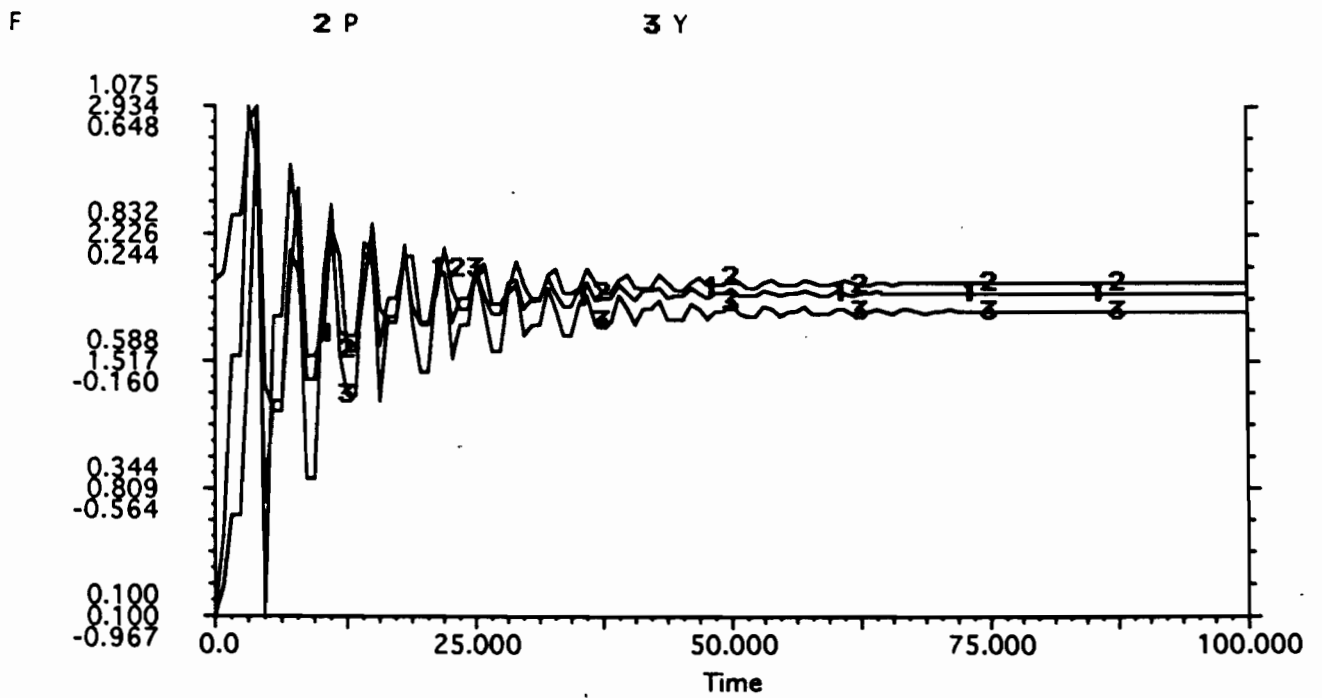

Figure 3. Prey-predator Relationships Between the Input Factors  $P_t$  and  $F_t$

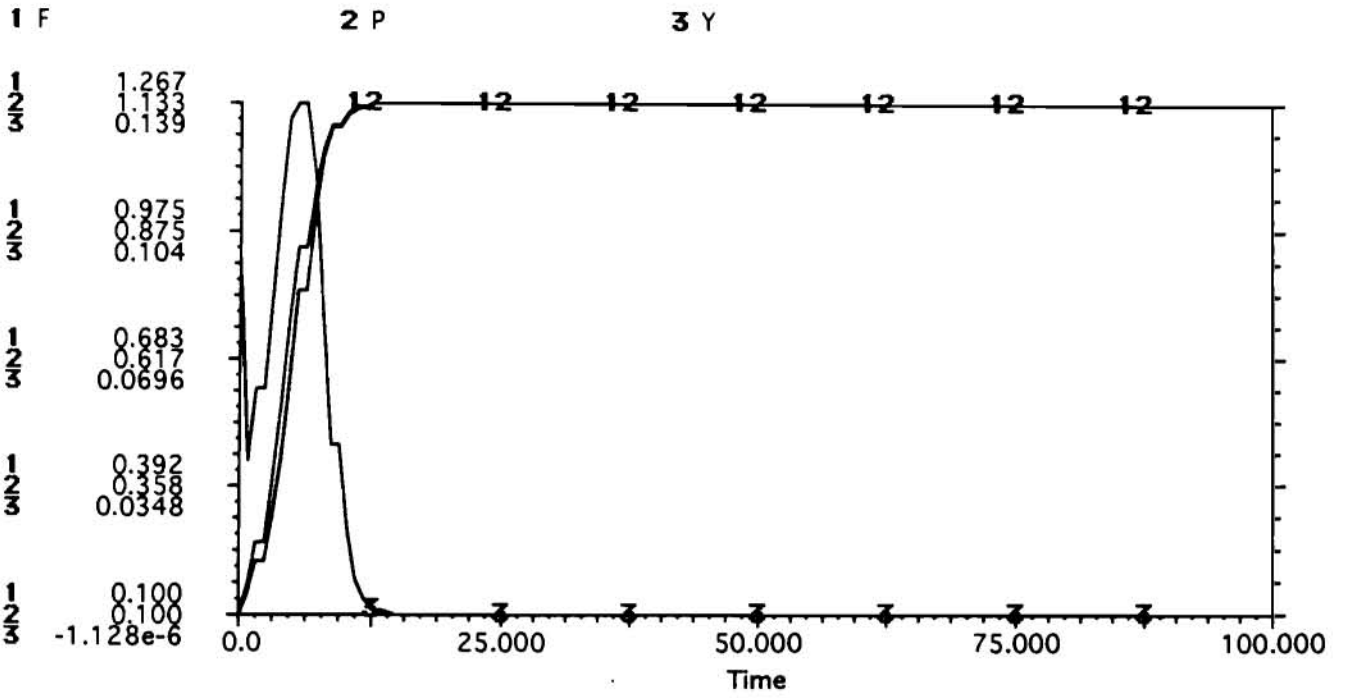

Figure 4. Symbiosis Relationship Between the Input Factors  $P_1$  and  $F_1$

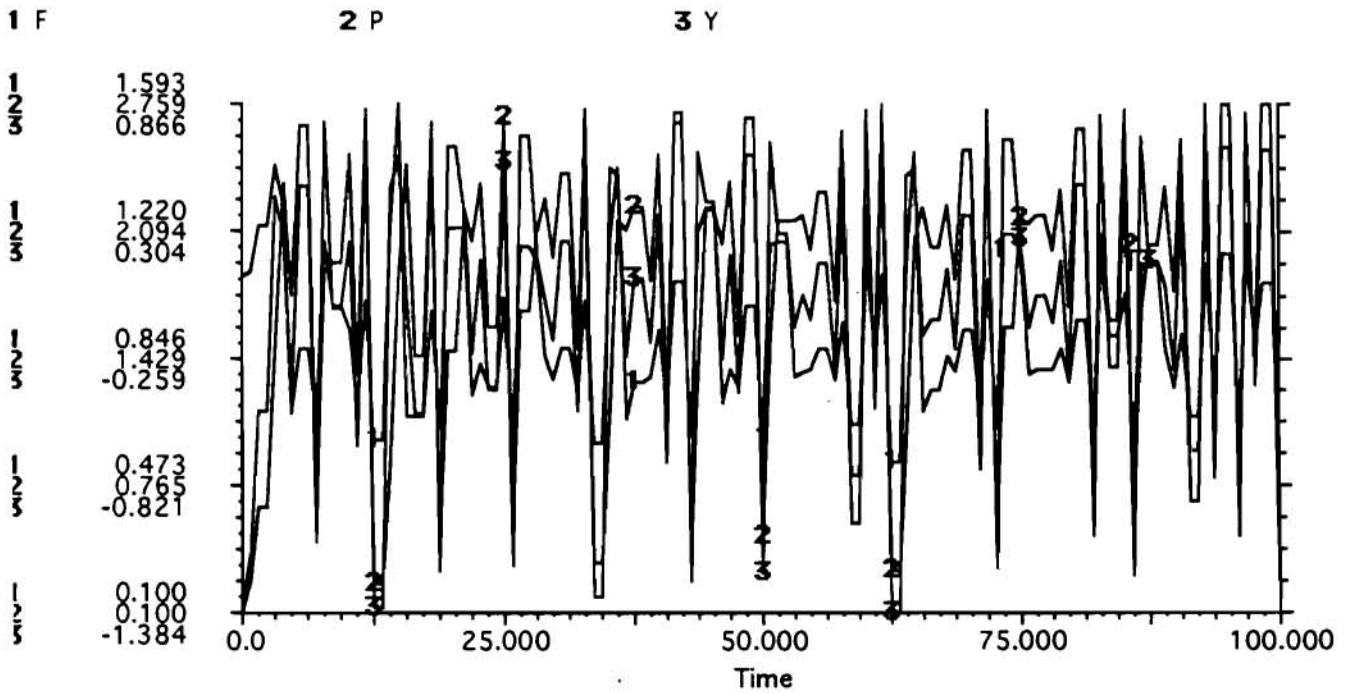

Figure 5. Prey-predators Relationships Between the Input Factors  $P_1$  and  $F_1$  by also Including  $Y_1$  as a Prey/predator Variable

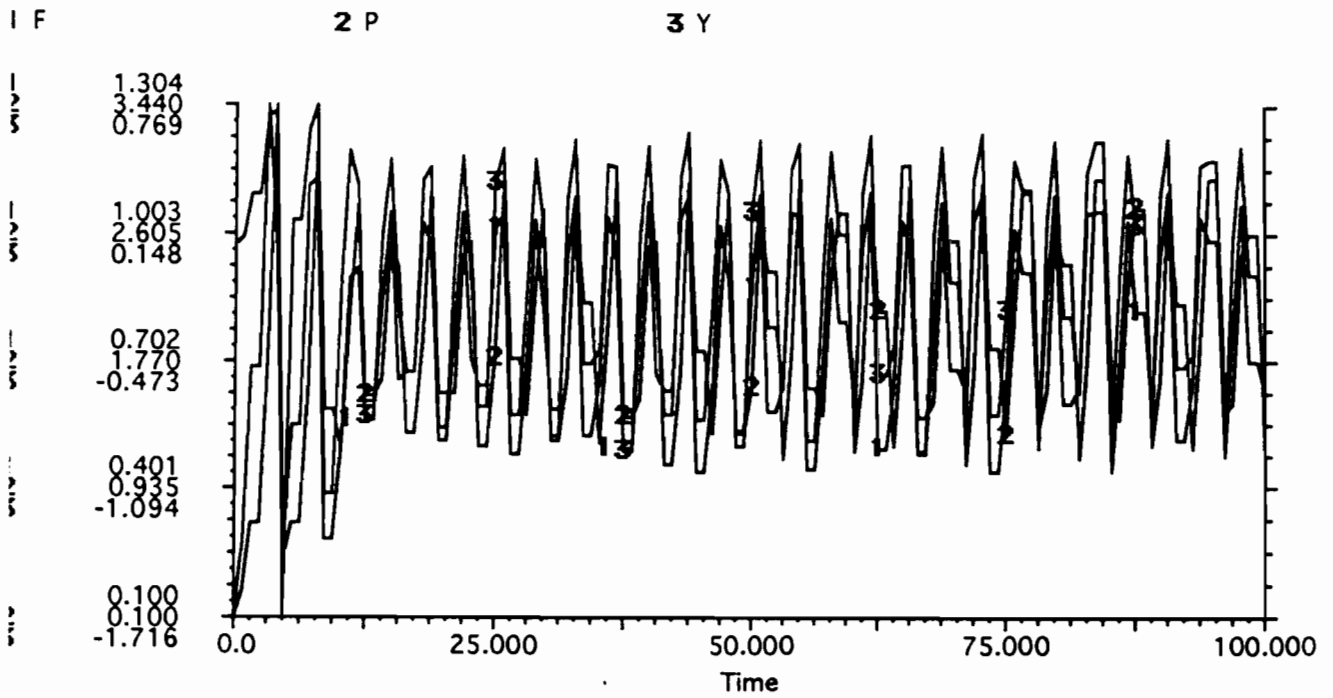

Figure 6. Prey-predator Relationships Between the Input Factor  $P_t$  and  $F_t$  by also Including  $Y_t$  in a Symbiotic Way

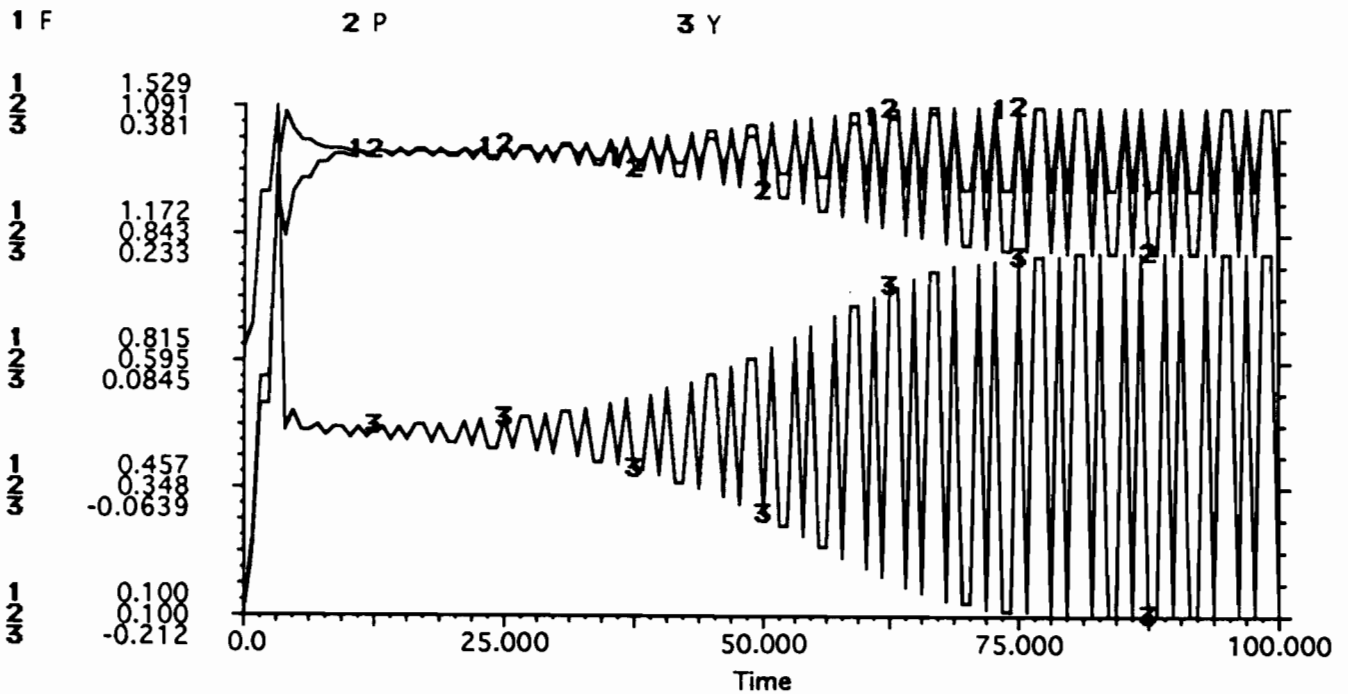

Figure 7. Competing Relationships Between the Input Factors  $P_t$  and  $F_t$  by also Including  $Y_t$  as a Prey-predator Variable

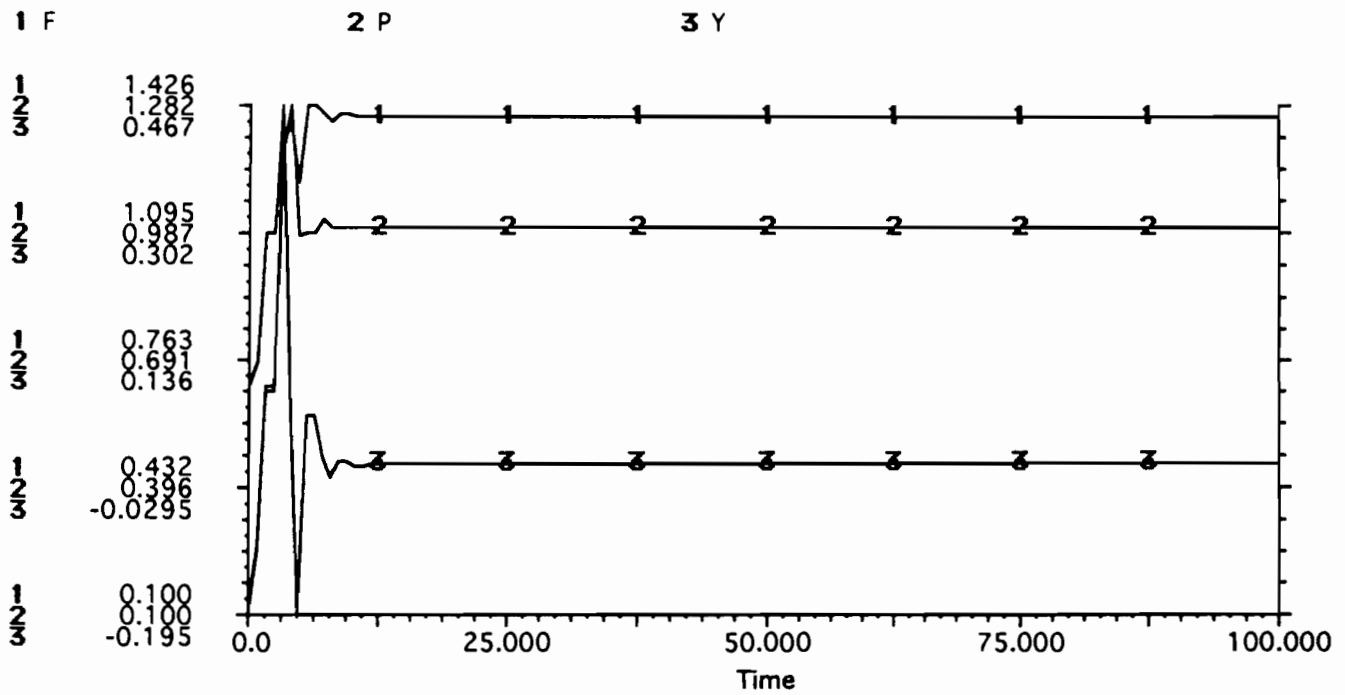

Figure 8. Competing Relationships Between the Input Factors  $P_i$  and  $F_i$  by also Including  $Y_i$  in a Symbiotic Way

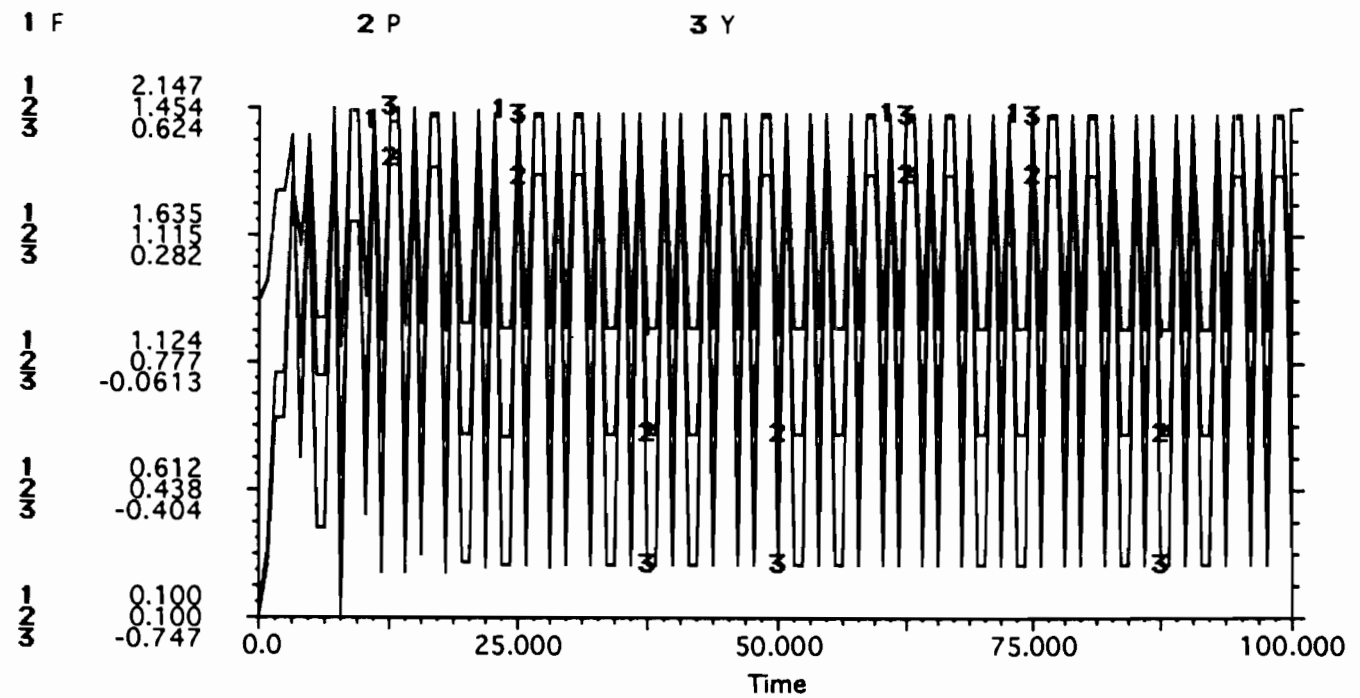

Figure 9. Unstable Behaviour Emerging by Increasing the Carrying Capacities

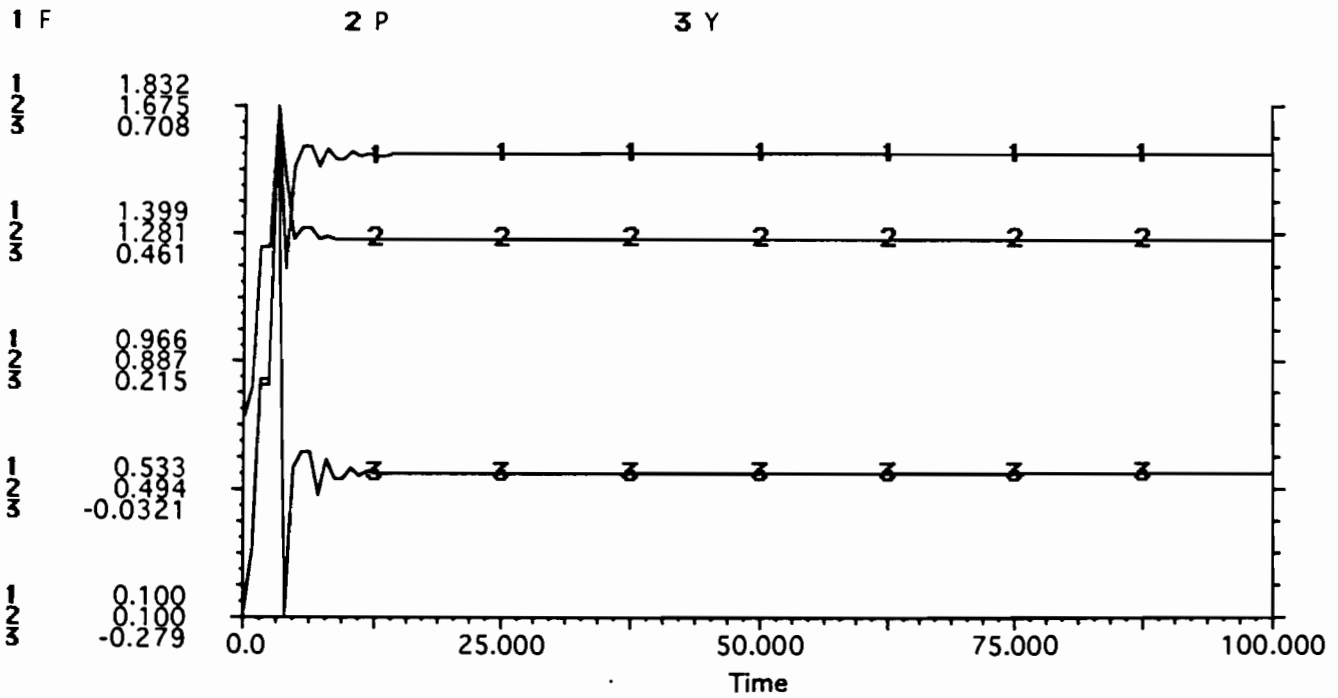

Figure 10. Competing Relationships Between the Input Factors  $P_t$  and  $F_t$  by also Including  $Y_t$  in a Symbiotic Way with an Increase in the Carrying Capacities

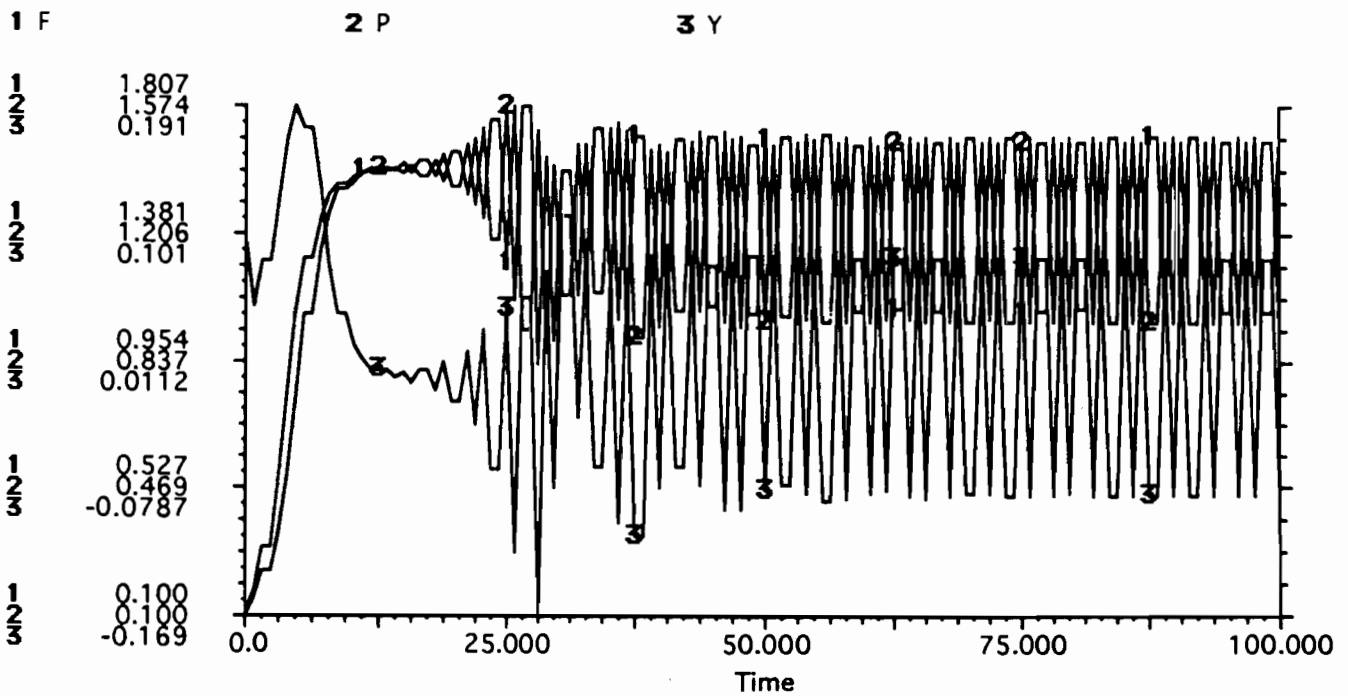

Figure 11. Symbiosis Relationships Between the Input Factors  $P_t$  and  $F_t$  by also Including  $Y_t$  as a Prey-predator Variable

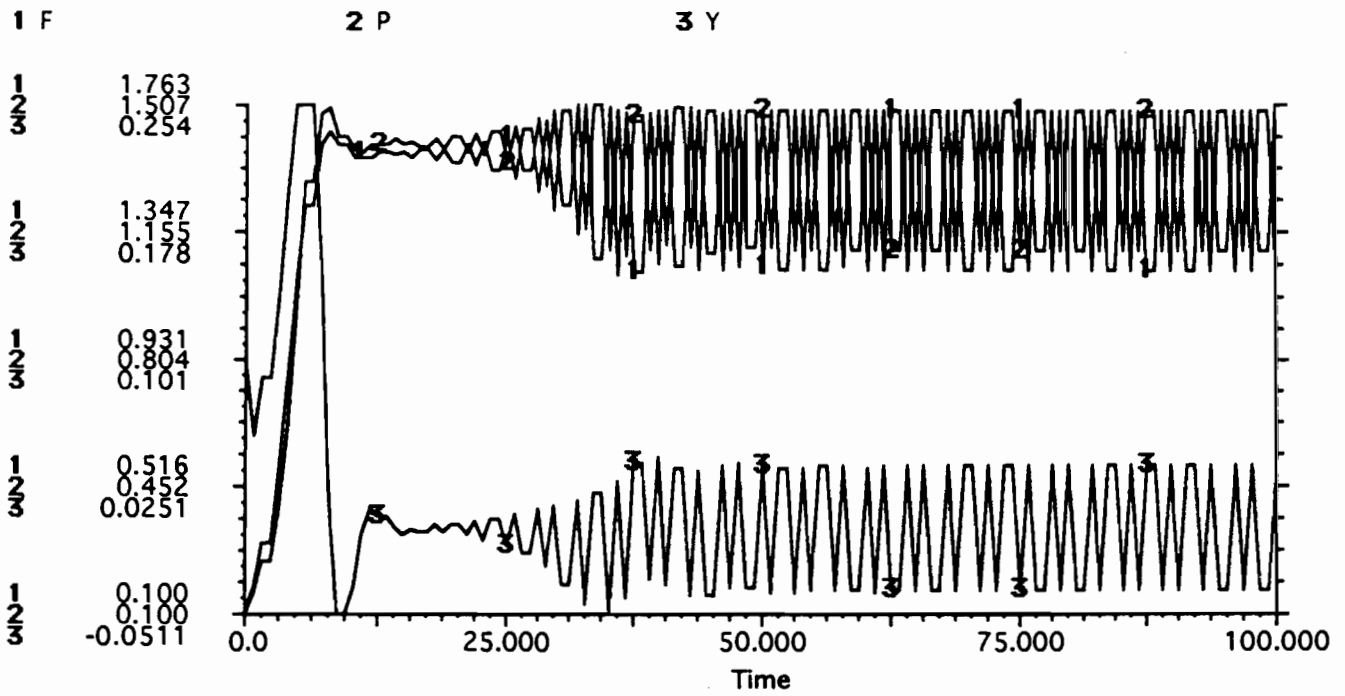

Figure 12. Symbiosis Relationships Between the Input Factors  $P_t$  and  $F_t$  by also Including  $Y_t$  in a Symbiotic Way

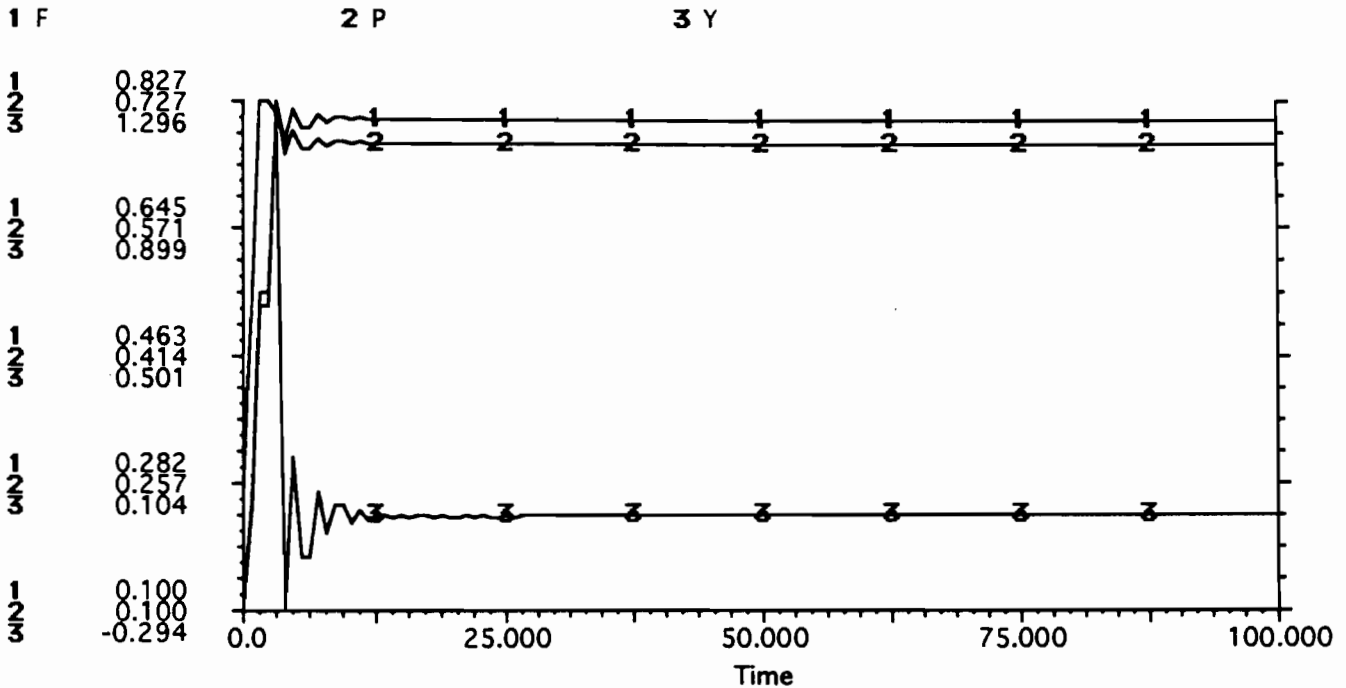

Figure 13. Dynamic Competition between the Input Factors  $P_t$  and  $F_t$  with a Linear Production Function

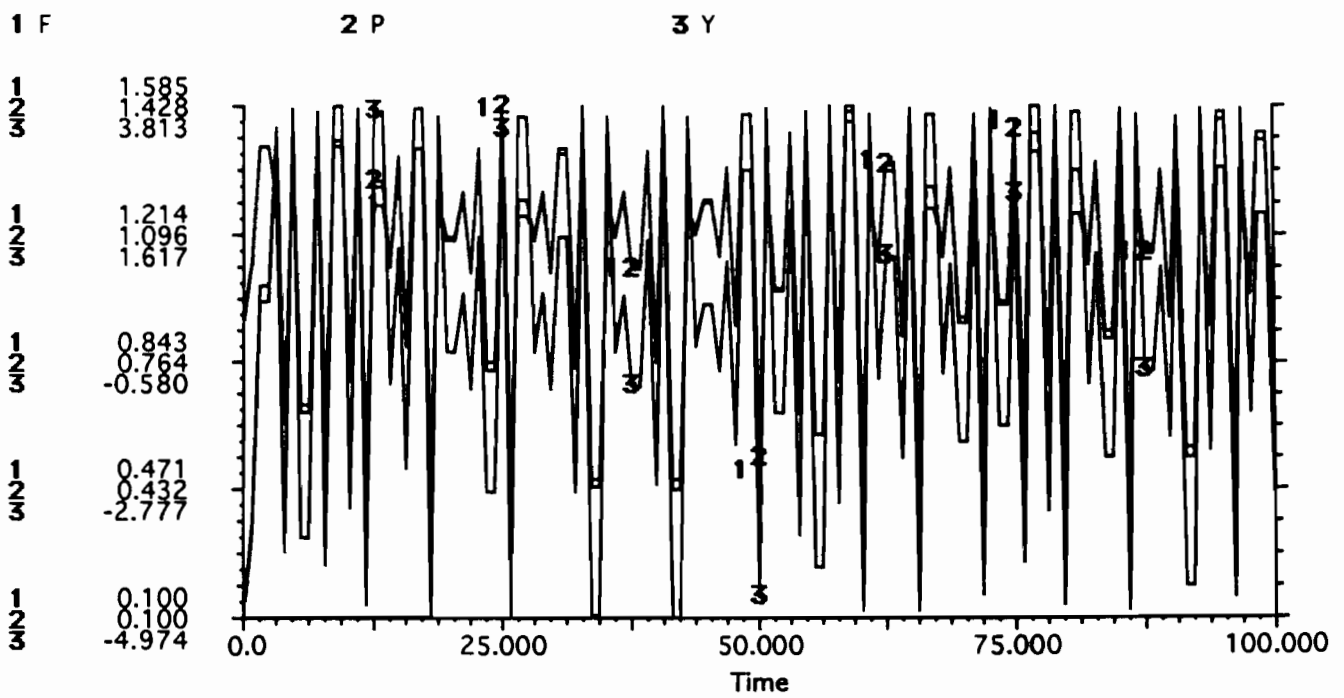

Figure 14. Unstable Pattern between the Input Factors  $P_t$  and  $F_t$  with a Linear Production Function

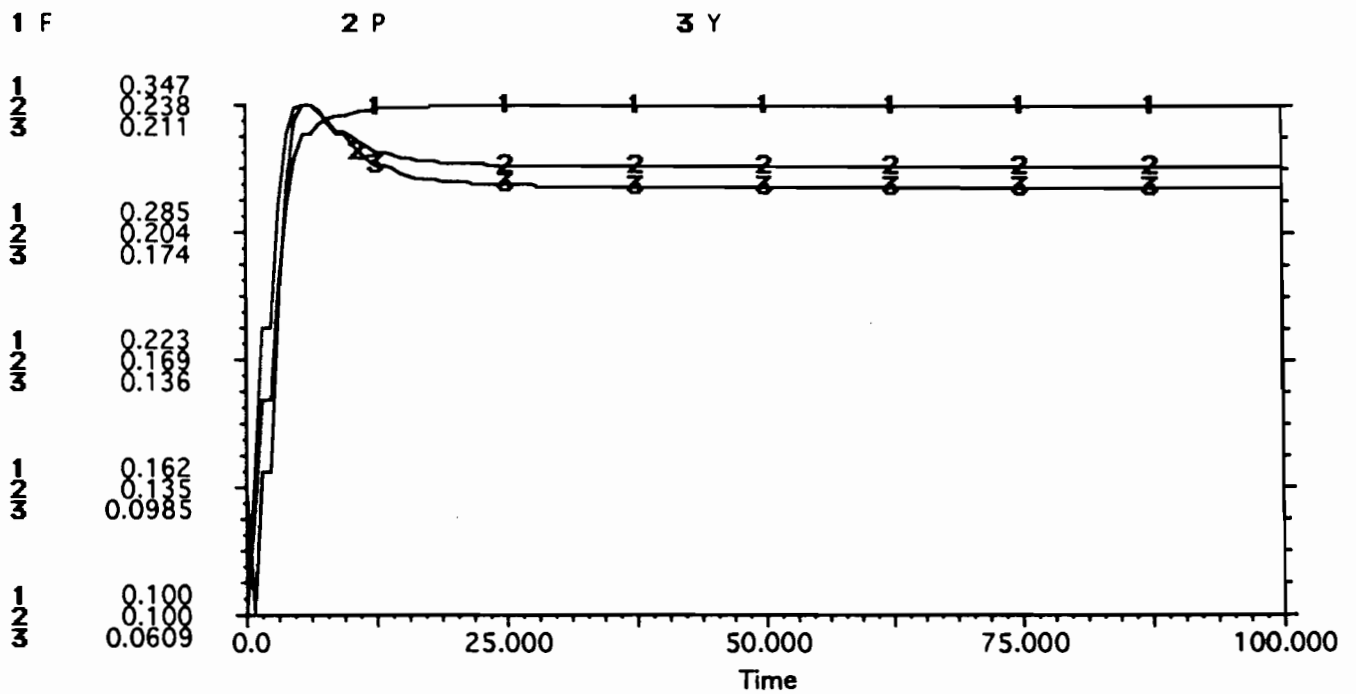

Figure 15. Dynamic Competition with a Logistic Growth of Relative Network Performance

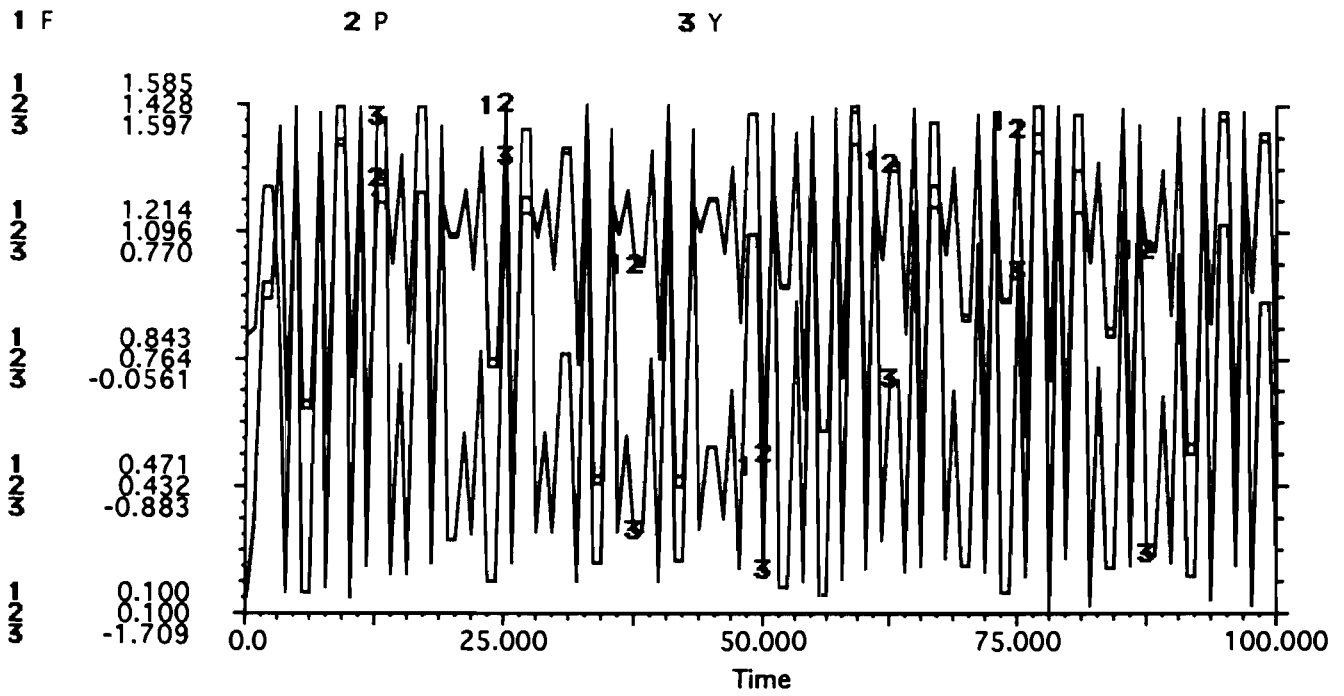

Figure 16. Unstable Pattern by Increasing the Carrying Capacities of Relative Network Performance

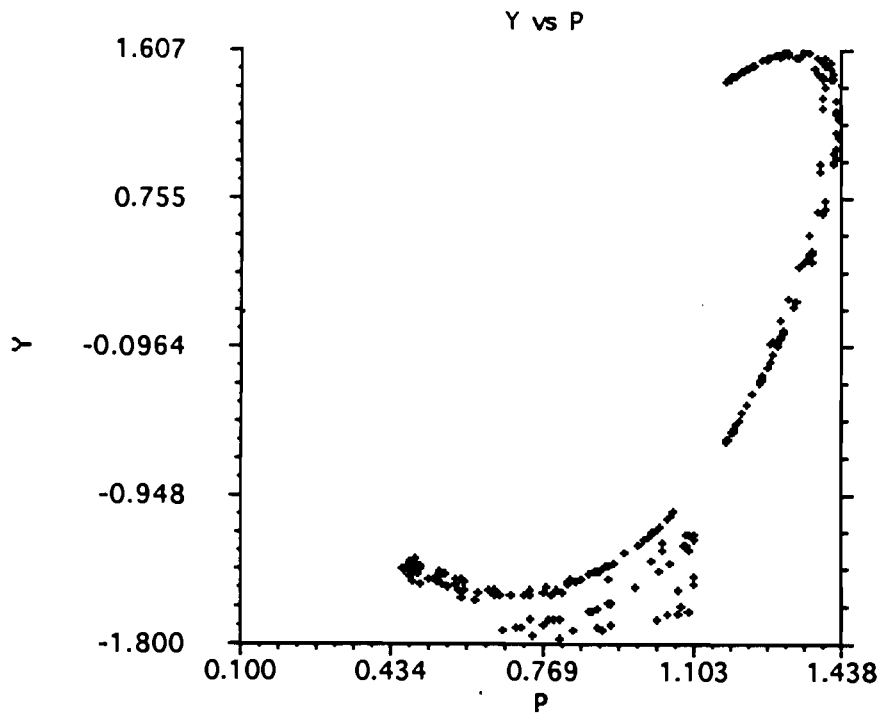

Figure 17. Strange Attractor - in a Loop Form - Emerging from Relative Network Performance



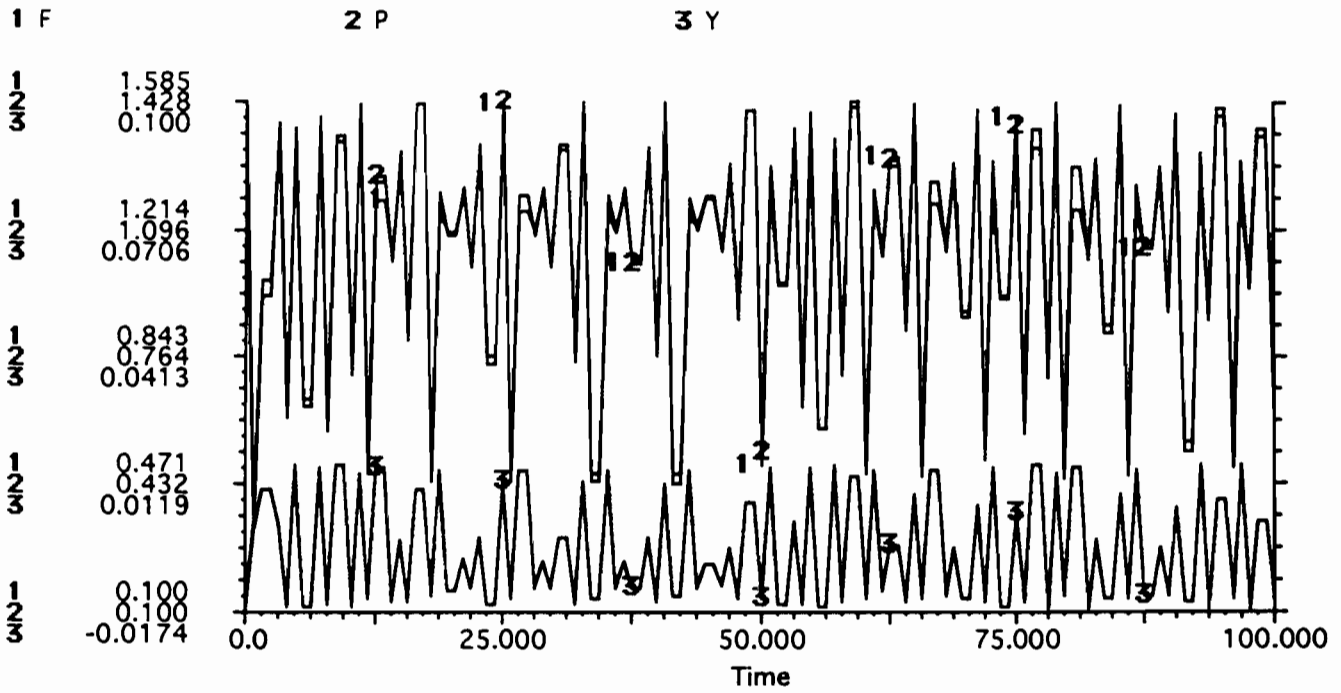

Figure 18. Unstable Pattern by Decreasing the Growth Rate of the Logistic Function of Relative Network Performance

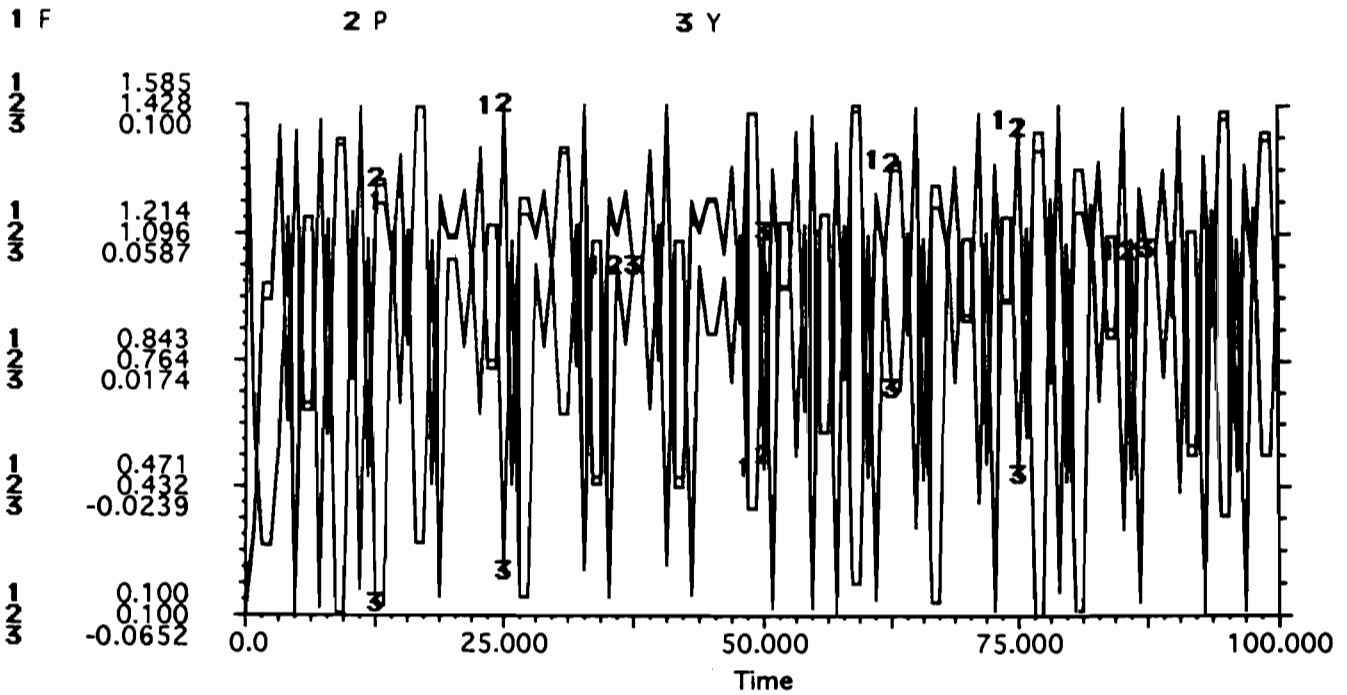

Figure 19. Unstable Pattern by Considering a Negative Growth Rate in the Logistic Function of Relative Network Performance

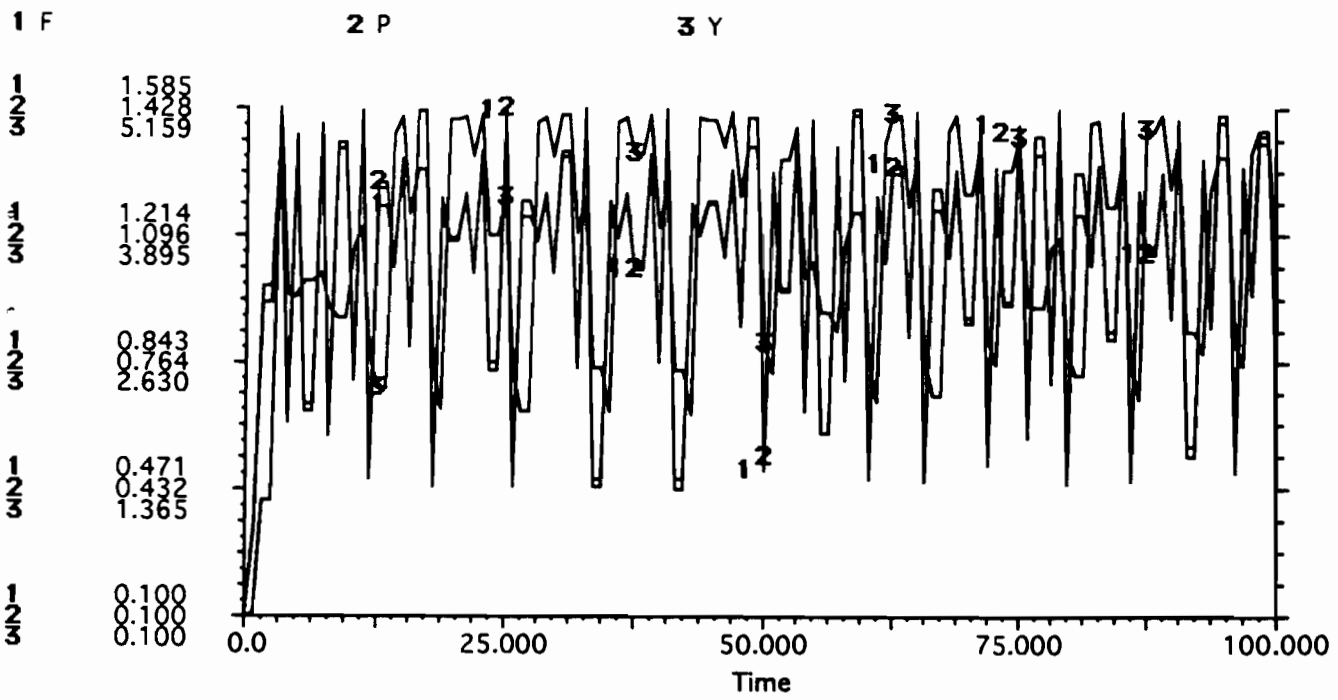

Figure 20. Dynamic Competition with a Linear Growth of Relative Network Performance

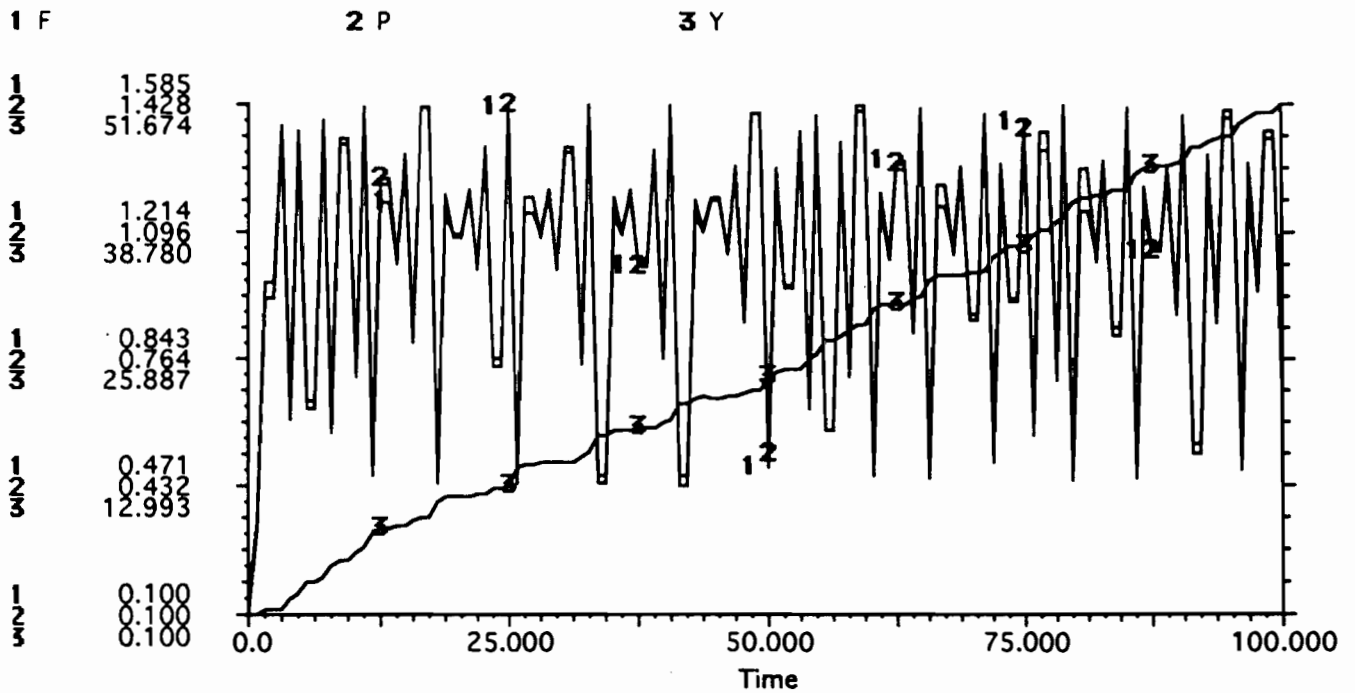

Figure 21 Dynamic Competition with a Generalized Logistic Growth of Relative Network Performance