

VU Research Portal

APPARATUS FOR DETECTING VIABLE MICROORGANISMS OR SPORES IN A SAMPLE AND USE THEREOF

Kort, R.; Duisterwinkel, Anton; Sandtke, Marijn; Lexmond, Axel

2010

[Link to publication in VU Research Portal](#)

citation for published version (APA)

Kort, R., Duisterwinkel, A., Sandtke, M., & Lexmond, A. (2010). APPARATUS FOR DETECTING VIABLE MICROORGANISMS OR SPORES IN A SAMPLE AND USE THEREOF.
https://nl.espacenet.com/publicationDetails/originalDocument?CC=WO&NR=2010151131A2&KC=A2&FT=D&ND=3&date=20101229&DB=EPODOC&locale=nl_NL#

General rights

Copyright and moral rights for the publications made accessible in the public portal are retained by the authors and/or other copyright owners and it is a condition of accessing publications that users recognise and abide by the legal requirements associated with these rights.

- Users may download and print one copy of any publication from the public portal for the purpose of private study or research.
- You may not further distribute the material or use it for any profit-making activity or commercial gain
- You may freely distribute the URL identifying the publication in the public portal ?

Take down policy

If you believe that this document breaches copyright please contact us providing details, and we will remove access to the work immediately and investigate your claim.

E-mail address:

vuresearchportal.ub@vu.nl

(19) World Intellectual Property Organization
International Bureau



(43) International Publication Date
29 December 2010 (29.12.2010)

PCT

(10) International Publication Number
WO 2010/151131 A2

(51) International Patent Classification:
C12M 1/34 (2006.01)

(21) International Application Number:
PCT/NL2010/050398

(22) International Filing Date:
25 June 2010 (25.06.2010)

(25) Filing Language: English

(26) Publication Language: English

(30) Priority Data:
09163937.7 26 June 2009 (26.06.2009) EP

(71) Applicant (for all designated States except US): **NED-ERLANDSE ORGANISATIE VOOR TOEGEPAST-NATUURWETENSCHAPPELIJK ONDERZOEK TNO** [NL/NL]; Schoemakerstraat 97, NL-2628 VK Delft (NL).

(72) Inventors; and

(75) Inventors/Applicants (for US only): **DUISTER-WINKEL, Antonie Ellert** [NL/NL]; Molukkenstraat 10, NL-2612 EC Delft (NL). **SANDTKE, Marijn** [NL/NL]; Spiegelmakerstraat 12, NL-2645 KW Delfgauw (NL). **KORT, Remco** [NL/NL]; Sarphatipark 10, NL-1072 PA Amsterdam (NL). **LEXMOND, Axel Sebastiaan** [NL/NL]; Leidseweg 159, NL-2253 AC Voorschoten (NL).

(74) Agent: **HATZMANN, M.J.**; Vereenigde, Johan de Wittlaan 7, NL-2517 JR Den Haag (NL).

(81) Designated States (unless otherwise indicated, for every kind of national protection available): AE, AG, AL, AM, AO, AT, AU, AZ, BA, BB, BG, BH, BR, BW, BY, BZ, CA, CH, CL, CN, CO, CR, CU, CZ, DE, DK, DM, DO, DZ, EC, EE, EG, ES, FI, GB, GD, GE, GH, GM, GT, HN, HR, HU, ID, IL, IN, IS, JP, KE, KG, KM, KN, KP, KR, KZ, LA, LC, LK, LR, LS, LT, LU, LY, MA, MD, ME, MG, MK, MN, MW, MX, MY, MZ, NA, NG, NI, NO, NZ, OM, PE, PG, PH, PL, PT, RO, RS, RU, SC, SD, SE, SG, SK, SL, SM, ST, SV, SY, TH, TJ, TM, TN, TR, TT, TZ, UA, UG, US, UZ, VC, VN, ZA, ZM, ZW.

(84) Designated States (unless otherwise indicated, for every kind of regional protection available): ARIPO (BW, GH, GM, KE, LR, LS, MW, MZ, NA, SD, SL, SZ, TZ, UG, ZM, ZW), Eurasian (AM, AZ, BY, KG, KZ, MD, RU, TJ, TM), European (AL, AT, BE, BG, CH, CY, CZ, DE, DK, EE, ES, FI, FR, GB, GR, HR, HU, IE, IS, IT, LT, LU, LV, MC, MK, MT, NL, NO, PL, PT, RO, SE, SI, SK, SM, TR), OAPI (BF, BJ, CF, CG, CI, CM, GA, GN, GQ, GW, ML, MR, NE, SN, TD, TG).

Published:

— without international search report and to be republished upon receipt of that report (Rule 48.2(g))



WO 2010/151131 A2

(54) Title: APPARATUS FOR DETECTING VIABLE MICROORGANISMS OR SPORES IN A SAMPLE AND USE THEREOF.

(57) Abstract: The present invention relates to the field of microbiology, more particular to an apparatus for detecting viable microorganisms or spores in a sample. Provided is an apparatus comprising an inlet for said sample, a sample immobilization area, a container comprising a composition comprising a phototautomeric compound, a light source and a detection unit. Also provided are the use of such an apparatus for detecting at least one viable microorganism in a sample, and the use of such an apparatus for detecting at least one viable spore in a sample.

Title: Apparatus for detecting viable microorganisms or spores in a sample and use thereof.

5

INTRODUCTION

The present invention relates to the field of microbiology, more particular to an apparatus for detecting viable microorganisms or spores
10 in a sample. Provided is an apparatus comprising an inlet for said sample, a sample immobilization area, a container comprising a composition comprising a phototautomeric compound, a light source and a detection unit. Also provided are the use of such an apparatus for detecting at least one viable microorganism in a sample, and the use of such an apparatus
15 for detecting at least one viable spore in a sample.

BACKGROUND OF THE INVENTION

Knowledge on the presence of viable microorganisms plays a role in
20 many food, environment and health issues. For food and drinking water safety and conservation treatments it is important to know whether (pathogenic) microorganisms are present in the samples or the areas where food is prepared and whether these are viable or not. As microorganisms are easily transported in air, it is of paramount interest to
25 be able to detect even single organisms in air samples. There is also a great need to adequately determine whether instruments and apparatuses used in hospitals, especially for surgery, contain viable specimens of that microorganism. Further, the presence of microorganisms in clean rooms and surgery theatres needs to be monitored.

30 These needs not only hold true for pathogenic microorganisms. For example, also for the increasingly popular pro-biotic food supplements it is important to know whether the beneficial microorganisms therein are

viable or not. Further, for testing the contamination of surfaces and/or the efficacy of disinfectants, e.g. in or on medical diagnostic devices and/or kitchen machinery, it is important to determine the presence of any viable microorganism. Thus, apparatuses for detecting the presence of viable
5 microorganisms are clearly needed. It may be clear that such an apparatus can also be suitably used for screening new antibiotic compounds.

Apparatuses for detecting viable microorganisms in air are known in the art. For example, US 3,566,114 disclosed an apparatus for detecting
10 viable bio-aerosols within the atmosphere. The apparatus comprises a light source, a light collector and a light detector. US 5,895,922 discloses a more sophisticated apparatus for on-line detecting viable bio-aerosols within an airstream. The apparatus comprises a flow chamber, a vacuum pump, a He-Cad ultraviolet (UV) laser and a photomultiplier tube. In the
15 apparatus, potentially hazardous biological particles are directed through air by air pressure and subjected to UV light from the laser. Whereas non-viable particles reflect the UV light, viable particles such as bio-aerosols emit fluorescence. This fluorescence is detected by the apparatus' photomultiplier tube. US 2008/204746 A1 describes a similar apparatus,
20 comprising a flow chamber, an air pressure regulator, two diode lasers, a photodetector and a photospectrometer. Both documents are thus able to measure fluorescence of living organisms. However, also dead organisms, dead biomaterials like flakes of skin, etc. can fluoresce. Thus, the apparatuses do not discriminate between live (viable) and dead material.
25 WO 03/05709 A2 describes an apparatus for detecting viable microorganisms in a gas, comprising a biocollector, a container comprising a marker such as an antibody or a dye, a container comprising a cleaning agent, a marker detection unit and a computer. However, by the use of such markers, the apparatus becomes specific for one type or class of
30 microorganisms and will not be able to detect microorganisms over the whole range. Further, as these apparatuses can only be used for detecting microorganisms in a gas their use is limited.

DE 101 58 964 describes an apparatus for detecting living cells in a solid, liquid or gas medium and use thereof. The apparatus comprises a light source, a light detector and a sample chamber suitable for containing a cell culture dish. The apparatus can be used for detecting living cells by measuring their growth over time, as they are cultured in the sample chamber. Similarly, US 5,366,873 discloses an apparatus comprising a light source, a light detector and a sample holder with an upper phase that is liquid and a lower phase that is semi-liquid. Viable microorganisms can be detected by monitoring the lower phase of the sample holder over time.

WO 88/07584 describes an apparatus for detection of viable bacteria in a sample. The apparatus comprises a photometer, a disposable test device and a luciferin-based reagent system. Use of the apparatus is rather time-consuming. Thus, not only are these apparatuses limited to detection in fluid samples, they are also restricted to types of on-line detection of viable microorganisms that do not require the apparatus' detection capability to be as fast as possible. For example, these apparatuses are completely useless in case of a suspected contamination with a lethal or otherwise extremely harmful microorganism whereby rapid application of countermeasures is required.

20

Not surprisingly, there is a great need for an alternative apparatus for detecting viable microorganisms or spores that is rapid, can detect all types of microorganisms and that is suitable for any type of medium.

25 SUMMARY OF THE INVENTION

The current invention provides such an apparatus. Provided is an apparatus for detecting at least one viable microorganism or spore in a sample, comprising: a) an inlet for said sample, b) a sample immobilization area, c) a container comprising a composition comprising a phototautomeric compound, d) a light source, and e) a detection unit. Preferably, said sample immobilization area is selected from the group

30

consisting of a plate, a filter, a container and a surface. Also preferably, said phototautomeric compound is selected from the group consisting of salicylic acid, 2-hydroxy-1-naphtoic acid, 1-hydroxy-2-naphtoic acid, 4-amino salicylic acid, 5-amino salicylic acid, gentisic acid, 4-hydroxy
5 salicylic acid, 3-amino-2naphtoic acid, o-hydroxycinnamic acid, 2-hydroxy-dibenzofuran-3-carboxylic acid (S350729), 6-amino-1,3-dimethyl-2-oxo-2,3-dihydro-1H-benzoimidazole-5-carboxylic acid, 5-(2-ethyl-butrylamino)-2-hydroxy-benzoic acid, 2-hydroxy-5-[(tertrahydro-furan-2-carbonyl)-amino]-benzoic acid, 7-amino-2,3-dihydro-benzo[1,4]dioxine-6-carboxylic acid and
10 2-hydroxy-5-tetrazol-1-yl-benzoic acid.

In one embodiment, said apparatus further comprises at least one separator. Preferably, said at least one separator is a porous membrane separator or a gas sampler.

In another embodiment, said sample immobilization area is
15 connected to said container. Preferably, the light source in the apparatus according to the invention is a monochromatic light source. More preferably, said monochromatic light source is a light emitting diode (LED).

In yet another embodiment, the detection unit of the apparatus is
20 an optical detection unit. Preferably, said optical detection unit is a camera. More preferably, said camera is a Charge Coupled Device (CCD) camera. Alternatively, the light source and the detector can be constructed into one unit.

Also provided is an apparatus that further comprises an optical
25 filter. Further provided is an apparatus, wherein said apparatus further comprises a light beam splitter. Even further provided is an apparatus according to the invention, wherein said detection unit is connected to a data processing unit. Preferably, said data processing unit is a computer.

The invention also provides for the use of an apparatus according to
30 the invention for detecting at least one viable microorganism in a sample. Preferably, said microorganism is selected from the group consisting of

bacteria, fungi, yeasts, algae, cell cultures of plant cells and cell cultures of animal cells.

In one embodiment, an apparatus according to the invention is used for detecting at least one viable spore in a sample. Preferably, said spore is
5 selected from the group consisting of a bacterial spore, a fungal spore or an algae spore.

Also provided is the use of an apparatus according to the invention for detecting at least one viable microorganism or spore in a sample, wherein said sample is selected from the group consisting of a gas, a fluid,
10 an aqueous solution, an emulsion, a dispersion, a liquid culture medium, a dissolved culture medium, a dissolved soil, a dairy product, a food product, blood, saliva, sputum, mucus, faeces and urine.

It should be understood that this invention is not limited to the
15 embodiments disclosed in this summary, but it is intended to cover modifications that are within the spirit and scope of the invention, as defined in the claims.

LEGENDS TO THE FIGURES

20

Figure 1: Schematic representation of an apparatus for detecting viable microorganisms in a fluid. The apparatus comprises an inlet for a sample, connected to a series of coarse porous membrane separators with decreasing permeability. The separators are connected to channels on the
25 sample plate. Each channel is connected to the container comprising a phototautomeric compound. The apparatus further comprises a light source, such as a LED, and a camera. The camera is connected to a data processing unit, such as a computer.

30 Figure 2: Schematic representation of an apparatus for detecting viable microorganisms in a fluid. The apparatus comprises a porous membrane separator. The separator is connected to a sample inlet, connected to a

channel on the sample plate. The channel is connected to the container comprising a phototautomeric compound. The apparatus further comprises a light source, such as a LED, and a camera. The camera is connected to a data processing unit, such as a computer. The channel on the sample plate
5 can be extended with channel extensions, providing a prolonged reaction time so that the apparatus can be used for detecting viable spores.

Figure 3: Schematic representation of an apparatus for detecting viable microorganisms in a gas, such as air. The apparatus comprises an inlet for
10 a sample, connected to a gas sampler. The gas sampler comprises a narrowing channel and is located on the sample plate. The gas sampler further comprises an activator compartment with porous walls. The activator compartment is connected to the container comprising a phototautomeric compound. The apparatus further comprises a light
15 source, such as a LED, and a camera. The camera is connected to a data processing unit, such as a computer.

Figure 4: Schematic representation of an apparatus for detecting viable microorganisms in a gas or a fluid. The apparatus comprises an activator
20 dosing system such as a spray nozzle from which a sample can be sprayed onto a sample plate. The sample plate may or may not be part of the apparatus. The plate is connected to a container comprising a phototautomeric compound. The apparatus further comprises a light source, such as a LED, and a camera. The camera is connected to a data
25 processing unit, such as a computer.

Figure 5: Image of fluorescent spores of *Bacillus subtilis* strain 168, activated by a phototautomeric compound. The image was taken by the use of the BX61 TRF fluorescence microscope (Olympus Inc.). The shutter
30 time of the camera was set at 1 second. The image was enlarged 400x.

Figure 6: Silicon CCD sensitivity

Figure 7: Schematic representation of an apparatus for detecting viable microorganisms using a simple fluorescence microscope.

Figure 8: Schematic representation of an apparatus for detecting viable
5 microorganisms using imaging directly on a CCD-chip.

DETAILED DESCRIPTION OF THE INVENTION

10 Definitions

The term “phototautomeric compound” as used herein is defined as any compound that can provide intracellular phototautomerism.

Phototautomerism refers to a phenomenon that occurs in certain
15 molecules containing at least two ionizing functional groups and involves photoexcitation to the lowest excited singlet state, which results in the “simultaneous” loss of a proton from one group and gain of a proton by another. Thus, phototautomerism occurs without any net ionization. Phototautomerism is frequently observed in polyfunctional molecules
20 containing at least one electron acceptor group (which becomes more basic in the excited state) and one electron donor group (which becomes more acidic in the excited state). If the electron acceptor group becomes sufficiently basic and the electron donor group sufficiently acidic upon
25 excitation, the acceptor group may become protonated and the donor group dissociated. This is usually observed as an anomalously large Stokes shift of the fluorescence, in other words the fluorescence band lies at much longer wavelengths than would be anticipated on the basis of the electronic structure of the neutral molecule. In so-called phototautomeric compounds or phototautomers, the electron acceptor and donor groups are
30 usually situated *ortho* or *peri* to one another on an aromatic ring, with an intramolecular hydrogen bond bridging the two functional groups (e.g. salicylic acid and 1-hydroxy-2-naphtoic acid, respectively). In some

instances, however, intramolecular hydrogen bonding occurs between aryl substituent groups and acidic or basic groups on side chains. Upon excitation, the hydrogen atom belonging to the electron donor group is transferred predominantly or entirely to the electron acceptor (ref:

- 5 Stephen G Schulman. Acid-Base Chemistry of Excited Singlet States in *Modern Fluorescence Spectroscopy, Part 2*. Edited by E.L. Wehry, Heyden London, 1976. Page 263-266)

Intramolecular phototautomerism in salicylic acid was first demonstrated by Weller, who noted that the fluorescence of salicylic acid
10 occurred at much longer wavelength (~ 410 nm) than that of *o*-anisic acid (~ 340 nm), the latter containing a methoxy group rather than a hydroxy group, so that phototautomerism is not possible (ref: A.H. Weller, Fast reactions of excited molecules, Prog. React. Kinet. 1 (1961), pp. 187–214). Various fluorescence emitting species of salicylic acid have been identified.
15 In concentrated sulfuric acid, emission from the cation is observed, whereas in concentrated KOH solution, the dianion is the emitting species. In alcohols, e.g. methanol, both the zwitterion and monoanion show emission, whereas in water only the monoanion shows emission (ref Joshi H.C.; Mishra H.; Tripathi H.B (1997) Photophysics and photochemistry of
20 salicylic acid revisited. *Journal of Photochemistry and Photobiology A: Chemistry*, 105:15-20). As the fluorescence emission in water is determined by the presence of the singly charged anion species, the intensity of the emission spectrum dramatically increases upon decreasing the acidity from pH 2 to pH 4 in line with the pKa value of 2.97 for the
25 aromatic carboxyl group in salicylic acid (ref: C.B. Amphlett, G.E. Adams and B.D. Michael, Pulse radiolysis studies of deaerated aqueous salicylate solutions, *Adv. Chem. Ser.* 81 (1968), pp. 231–250), as demonstrated in Fig. 2 and 3 for the phototautomeric compounds: salicylic acid and 1-hydroxy-2-naphtoic acid, respectively. Thus, as the pH interval from 2 to 4
30 is traversed, the fluorescence changes to that of the excited singly charged anion ionized at the phenolic group, the latter being formed only by the

direct excitation and rapid intramolecular phototautomerization of the singly charged ground-state anion (ionized at the carboxyl group).

Compounds that are useful as phototautomeric compounds in the present invention are the above mentioned salicylic acid, 2-hydroxy-1-
5 naphthoic acid, 1-hydroxy-2-naphthoic acid, quinolines, isoflavones, uracil and derivatives thereof in which the phototautomeric characteristics are maintained. A list of specific, preferred compounds is given in Table 1.

Table 1. Overview of fluorescent compounds which can be used for real-time monitoring of
10 cell viability. A solution of 100 μ l containing 50 μ M compound in 100 mM potassium phosphate buffer pH 7 is used for recording the excitation and emission wavelengths in a Tecan microplate fluorometer. The ratio of emission intensity at pH 7.5 and 1 as well as the ratio of emission intensity at pH 7 and 2 (indicated by the asterisk) was recorded with 100 μ l solution containing 50 μ M compound in 100 mM potassium phosphate buffer pH 2 or 7 in a Tecan microplate fluorometer at optimal excitation
15 wavelength. Uptake of compounds by viable and nonviable (heat-inactivated for 5 minutes at 95°C) *Staphylococcus aureus* ATCC 6538 and *Sachromyces serervisiae* ATCC 9763 cells is real-time monitored in a Tecan microplate fluorometer at optimal excitation and emission wavelengths. A solution of 50 μ M compound in 100 mM potassium phosphate buffer pH2 was added to 100 μ l cell suspensions at t=20 seconds, uptake of compound was monitored for 180 seconds.

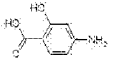
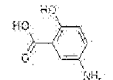
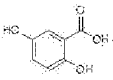
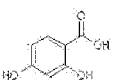
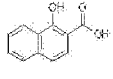
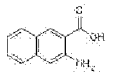
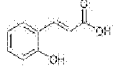
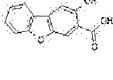
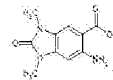
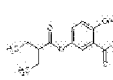
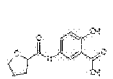
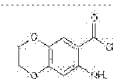
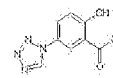
code	name	structure	excitation maximum (nm)	emission maximum (nm)	pKa	ratio pH7.5/1 or pH7/2*	uptake bacteria	uptake yeast
V1	salicylic acid		295	465	2.9	122	+	+
V2	4-amino salicylic acid		295 (265)	400	2.2 (3.5)	22 (74)	+	-
V3	5-amino salicylic acid		335	495	5.8	331	-	-
V4	5-hydroxy salicylic acid (gentisic acid)		322	448	2.9	77	+	-
V5	4-hydroxy salicylic acid		290	395	3.0	52	+	-
V6	1-hydroxy-2-naphthoic acid		340	420	3.0	3	+	+
V7	3-amino-2-naphthoic acid		360 (285)	470	4.5	88 (42)	+	+
V8	o-hydroxycinnamic acid (o-coumarine zuur)		320 (360)	500	5.5 (>9)	30 (400)	+	-
V9	S350729 2-Hydroxy-dibenzofuran-3-carboxylic acid		340 (300)	450	2.3	4.3 (3.7)	+	+
V10	6-Amino-1,3-dimethyl-2-oxo-2,3-dihydro-1H-benzimidazole-5-carboxylic acid		241	396	n.d.	1.4*	-	+
V11	5-(2-Ethylbutylamino)-2-hydroxy-benzoic acid		311	425	n.d.	22.9*	+	-
V12	2-Hydroxy-5-[(tetrahydro-furan-2-carbonyl)-amino]-benzoic acid		307	417	n.d.	17*	+	-
V13	7-Amino-2,3-dihydro-benzo[1,4]dioxine-6-carboxylic acid		323	401	n.d.	359*	+	-
V14	2-Hydroxy-5-tetrazol-1-yl-benzoic acid		296	395	n.d.	5*	+	-

As used herein, “witness plate” means any surface or medium that can be used to immobilize microorganisms, especially for ‘catching’ microorganisms in gas or liquid streams. The plate can for instance be a

filter or a membrane that has pores that allow passage of a gas or liquid but through which microorganisms can not pass. It can also be a flat, non-porous surface along which an air or liquid stream is passed and to which microorganisms will stick, e.g. a surface with a gel coating that is placed
5 in an air stream. It is also possible that the witness plate is coated with molecules that specifically bind to microorganisms to improve the immobilization capacity of the plate. Alternatively, immobilization of the microorganisms on the plate can be achieved with an electrical field or through ionic immobilization.

10

Description

The embodiments of the apparatus according to the invention depend on the medium in which the microorganisms are located, the
15 method of sampling and whether analysis is performed on-line or off-line.

Sampling of the sample in which (potentially) a microorganism or a spore is located should be performed easily. Sampling can be done -on-line, meaning that continuously or intermittently with short intervals samples are taken which are directly processed in the apparatus of the invention,
20 enabling a continuous monitoring. In off-line sampling there is no direct coupling to the assay, which can take place any time after collection of the sample(s). Off-line sampling thus permits that parts of the apparatus are not physically connected to each other, more specifically that the sample taking part of the apparatus can be separate from the rest of the
25 apparatus.

In off-line sampling of air the microorganisms can be 'caught' on a sample collecting means. This can be any form of a collection means where the microorganisms are fixed, such as a filter or any form of a 'witness plate',
30 or a petridisk with fluid (gel or an aqueous solution). The microorganisms (if any) will gather in, adhere to or become fixed to the collection means, which after some time is collected and presented for assaying.

When detection need to be performed of microorganisms in fluids, such as polluted water, bioprocessors, and the like, a similar collection of microorganisms can be performed. Samples can be taken from the fluid, which optionally can be concentrated through microporous membranes. It would also be possible to put such microporous membranes in the fluid stream which then will collect any microorganism that is contained in the fluid that streams through the membrane. In this way it is also possible to make a first distinction as to the size of the microorganism by using membranes with different pore sizes. This would facilitate a classification of the microorganisms that are detected.

The actual detection of the microorganisms takes place by the mechanism of phototautomerism, as is exemplified in international patent application WO 2009/082218.

Key in this method is using fluorescence emission, which makes it possible to discriminate between the phototautomeric compound being in conditions of low pH or being in conditions of high pH. A condition of low pH is herein defined as a pH of the solution, in which the phototautomeric compound is dissolved, in which the protonated or neutral acid form of the compound is responsible for the fluorescence (preferably no or low emission), whereas a condition of high pH is defined as the pH of the solution, in which the phototautomeric compound is dissolved, in which the singly charged anion form of the compound is responsible for the fluorescence (preferably high emission).

Although one is inclined to think that the pivotal point for the shift in fluorescence state (i.e. whether the phototautomeric compound will emit fluorescence or not) is the pKa value of the compound, this is not exactly true. It is therefore better to define a new parameter, the pKf, which is the $-\log [H^+]$ concentration of the medium in which the phototautomeric compound is dissolved below which point the compound is in another fluorescent phase than above. This pKf value can easily be

obtained for each compound by continuously decreasing or increasing the pH of a solution of the compound and to determine at which point the compound starts or stops to emit fluorescence. Generally, the pKf will be in the neighbourhood of the pKa of the compound.

5 The intracellular pH in living microbial cells varies between 4.5 and 8. If pH 4.5-8 is defined as a “high pH” and a phototautomeric compound in a “low pH” solution is added to the microbial cells, then upon excitation the fluorescence emission will differ between the individual phototautomeric molecules that remain outside the cell (absent or low
10 fluoresce) and those that have been transferred into the intracellular medium (present or high fluorescence). If microbial cells start to leak or burst open, the acidic medium solution can enter the cell, which acidifies and wherein thus the phototautomeric compound will eventually be in a “low pH” condition. The process of transfer (either actively or passively) of
15 the compound in the cell and death of the cell through membrane-leakage can advantageously be followed by real-time fluorescence measurements. In this way the fluorescence measurements give an indication on the presence of living (i.e. viable) cells and the deterioration rate of the cells rate in the acidic medium.

20 Accordingly, the present invention makes use of the pH dependent fluorescence characteristics of phototautomeric compounds, such as salicylic acid, 1-hydroxy-2-naphtoic acid and 2-hydroxy-1-naphtoic acid and compounds presented in Table 1, to discriminate between living and dead cells

25 It is known that cell membranes are affected by weak organic acids, such as the phototautomeric compounds described above. For lactic acid an effect has been described on bacterial cells (see Alakomi, H.-L., et al., 2000, Appl. Environment. Microbiol. 66(5):2001-2005), while for salicylic acid and dihydroxy benzoic acid an effect has been described on
30 human and murine leukemia cells (Feix, J.B. *et al.*, 1994, Cancer Res. 54:3474-3478). The exact effect of the compounds is unclear, and it seems that different acids would have different effects. For instance, lactic acid is

said to be a potent membrane disrupting agent (even stronger than hydrochloric acid), while salicylic acid is said to change membrane potentials. Further, both lactic acid and salicylic acid have a biocidal effect.

5 The medicinal properties of salicylate, mainly for fever relief, have been known since ancient times, and it was used as an anti-inflammatory drug.

 Salicylic acid is characterised in that it has a difference in fluorescence emission intensity (at 402 nm) at excitation (290 nm) at
10 different pHs. As indicated above, this difference in signal intensity can be advantageously used in combination with the above mentioned effects of these acids on the membrane of micro-organisms. Cells that take up the salicylic acid will slowly acidify and eventually obtain a pH which is equal to the pH of the medium. Thus, by monitoring the fluorescence emission,
15 living cells can be identified and the process of acidification, resulting in cell death, can be monitored. It appears that this acidification process, at least in *S. aureus*, has a time constant of 0.005 s^{-1} (data not shown). However, this varies from micro-organism to micro-organism, where it is believed that the acidification process is faster in Gram-negative micro-organisms, such as *E. coli*, than in Gram-positive organisms, such as *S.*
20 *aureus*. Strikingly, *S. cerevisiae* shows an increase in fluorescence in the first 500 seconds, which is in line with the higher acid tolerance of this organism. Further, in *S. cerevisiae* there is a relatively slow rise in fluorescence in contrast to the rapid rise in bacteria, showing that the cell
25 membrane of *S. cerevisiae* is less-permeable to salicylic acid.

 In the prior art (Garcia-Sancho, J and Sanchez, A., 1978, Biochim. Biophys. Act., 509:148-158) salicylic acid has been used to estimate the pH inside the (bacterial) cell. This was achieved by assessing the distribution of radioactively labeled salicylic acid between the
30 intracellular and the extracellular phase. However, since no pH conditions under pH 4.3 were tested, the authors did not recognize the phenomenon

that is the subject of the present invention which would enable to test for the viability of the micro-organism.

This principle is now integrated in the present apparatus that can be used to detect the presence of viable micro-organisms. In this
5 respect, the medium to be sampled can be selected from the group of air, an aqueous solution, emulsion or dispersion, a culture medium, soil, a dairy product and a food product. Thus, such an apparatus can be used for the testing of food, air and water contamination, and contamination of surfaces (such as from diagnostic or therapeutic devices, surgical invasive
10 and non-invasive instruments or apparatuses, and surfaces on which food is stored or prepared).

As can be derived from the above explanation of the phototautomeric effect, viable microorganisms can only be activated and detected in a fluid. This means that if a gas or a gas mixture is to be tested
15 with the apparatus, the microorganisms have to be captured in a fluid. Viable microorganisms in a sample are activated by adding a phototautomeric compound to the sample. This can be performed by either adding the phototautomeric compound to the sample, or by adding the sample to the phototautomeric compound. Care should be taken that the
20 pH of the solution in which the microorganism is measured is below the pKf value of the phototautomeric compound. This step of bringing the liquid sample containing the microorganism together with the phototautomeric compound in an environment of low pH is herein defined as "activation step". It can be done by guiding a solution with the
25 phototautomeric compound to the micro-organisms by spraying the surface area with a solution with the phototautomeric compound or to 'catch' the microorganisms on a surface that already contains the phototautomeric compound solution.

30 It has also been found in WO 2009/082218 that the variety in phototautomeric compounds that can achieve this effect, and which thereby are characterized by their fluorescence at different wavelengths,

also can accommodate in making a distinction in the type of micro-organism that is detected. For instance there are phototautomeric compounds which are taken up by both bacteria and yeast (such as salicylic acid, 1-hydroxy-2-napthoic acid, 3-amino-2-napthoic acid and S350729), while other compounds are hardly taken up by yeast (such as 4-hydroxy salicylic acid, 4-amino salicylic acid, 5-amino salicylic acid and o-hydroxycinnamic acid). It is also contemplated that there will be compounds that are especially useful in Gram-negative bacteria or Gram-positive bacteria. Use of a combination of these compounds in one assay, whereby detection takes place at two or more wavelengths, can thus already give an indication of the type of micro-organism that is detected. In this way thus a classification of microorganisms can be achieved.

Further, the apparatus according to the invention is applicable to determine the viability of microorganisms. A great advantage is that the effects of the addition of a phototautomeric compound to a culture of microorganisms can be measured real-time, and that a typical test run only requires little time. Next, since the measuring of fluorescence is a commonly used optical assay method, it is possible to use standard optical equipment in the apparatus of the invention. Further, the standard read-out systems accommodate various types of phototautomeric compounds, media and buffers that can be used in the method of the invention. For testing the viability of a micro-organism an appropriate sample is e.g. placed in a suitable container (e.g. a well), fluorescence is measured at 402 nm (to determine the background level) and, while continuing the fluorescence measurements, a solution of the phototautomeric compound at the discriminatory (high or) low pH condition is added to the well. Appropriate controls would be a container with no added phototautomeric compound, a container comprising viable cells and a container comprising dead cells. The amount of phototautomeric compound needed for a useful assay can be detected through testing various concentrations, but will normally vary from 0.01 mM to 10 mM, and the resulting pH of the solution should not be close to pH 7. The desired pH depends on the

phototautomeric compound used. A pH of about 2 is preferred for salicylic acid and is reached with a solution of 1-2 mM salicylic acid in a 100 mM potassium phosphate buffer.

5 In principle all varieties of micro-organisms can be detected in the assay, such as bacteria, fungi, algae, cell cultures of animal and plant cells, etc. One of the main advantages of the present apparatus is that it can detect single microorganisms. Preferably the apparatus is used to detect bacterial cells. It has also proven possible to determine the viability
10 of bacterial and fungal spores (see the experimental part of WO 2009/082218 and Fig. 5). Although the timeframe of an assay in which the viability of spores is assessed is much larger than the timeframe in which the viability of bacteria or other cellular organisms is tested (minutes versus seconds, respectively), such an assay should be considered as a
15 major improvement over the currently known assays. Similarly, this would also apply for an apparatus to perform the assay. This difference between spores and other microorganisms also enables a classification into these two groups.

 Using the above described assay it is also possible to use the
20 apparatus of the invention to assay the antibiotic effect of chemical or biological compounds by adding them to the micro-organism and testing the viability of the cells which have undergone such a treatment. The microtiter plate design of the test allows for the testing of series of compounds or various concentrations of one compound. In the latter case,
25 it is especially suitable to establish an IC_{50} . Other variations may be the time that the micro-organisms are exposed to the compound to be tested and changes in the conditions of exposure (i.e. temperature, pH, osmolarity of the buffer, etc.). Herewith a cost efficient and versatile apparatus to perform the assay for the detection of antibiotic compounds is
30 provided.

The apparatus of the invention can also be used to measure the fitness of the micro-organisms. As can be seen from the figures in WO 2009/082218

(e.g. Fig. 4, 5) the micro-organisms that are contacted with the phototautomeric compound will slowly die as a result from leakage of the acidic medium into the bacterial cell, causing a gentle slope in the fluorescence over time. The rate with which the cells die is a measure for the viability of the cells, and thus the slope of the fluorescence emission over time, which reflects the rate death of the microorganism, is a good measure for the determination of the fitness of the bacteria. Such a determination is important when microorganisms are cultured, used in probiotics or used as starter cultures for food fermentations, such as cheese production, sausage production, beer and wine production and for bacterial treatments of plant pathogens.

Directly after the viable microorganisms in the sample have been activated by the phototautomeric compound, any viable microorganism will emit fluorescence during a certain period of time. Such a period may last anywhere between one to hundreds of seconds. Because some of the microorganisms will emit a fluorescent signal that will last only a short time and the extinction of that signal provides relevant information about the type or species of that microorganism, the fluorescence signal should be detected immediately after the microorganism has been activated. Also, the moment at which the microorganisms are activated should be known as exact as possible. Therefore, the activation step is preferably performed inside the apparatus.

Detection of the microorganism takes place by measuring the emitted fluorescence at a certain wavelength (see Table 1 for the wavelengths applicable to the phototautomeric compounds that are useful in the apparatus of the invention). Measuring the fluorescence is preferably done by optical means, such as a camera, more preferably a CCD array camera. Alternatively, a semiconductor PIN detector may be used. As a light source preferably a monochromatic light source such as a LED can be used. Also applicable is a normal light source and a filter that

is transparent for the specific wavelength needed for excitation of the phototautomeric compound. If needed, lenses and mirrors can be used to focus or direct the light beams. The light source and the camera for measuring fluorescence are preferably placed under an angle with respect to each other to prevent direct lighting or reflection of the light source into the camera, thereby improving the signal to noise ratio. This also diminishes the need to use high qualitative (i.e. expensive) filters. It is also possible to place the light source on one side of the surface that needs to be imaged and placing the detection camera at the other side of the surface. Of course, in such a case, the surface should be transparent for the light or the fluorescence radiation.

The size of the surface or volume that can be detected will depend on the intensity of the light source and the sensitivity and resolution of the camera, where resolution can be improved by using appropriate optical filters.

With a 16M pixel camera, a standard objective and a standard optical filter it will be possible to image a surface of several cm² and still be able to have a resolution that is sufficient to detect and visualize the microorganisms. Standard as used above means commercially obtainable, not expensive components.

The area to be imaged can be increased by making the optical detection system scan a larger surface, either by moving the camera and light source or by moving the detection surface or volume. Accordingly, there is no actual limit to the maximum detectable area. Means for moving the components of the apparatus can be of any known type and are readily available to the person skilled in the art.

The apparatus can be used to determine viable microorganisms in any type of medium. Suitable media are for example, but not limited to, a gas, a fluid, an aqueous solution, an emulsion, a dispersion, a liquid culture medium, a dissolved culture medium, a dissolved soil, a dairy product, a food product, blood, saliva, sputum, mucus, faeces and urine.

One of the advantages of the apparatus of the invention is that it can perform detection of microorganisms and spores real-time. This means that use of the apparatus minimizes response times and processing costs, which in turn minimizes the costs caused by a microbial contamination.

Further, since there is no actual limitation to the use of the apparatus, said apparatus can also be used in vacuum conditions, like in and on space vessels, to prevent introduction of terrestrial microorganisms to newly discovered planets and worlds.

Also, the invention will be applicable in circumstance wherein there is a major risk for human safety, such as in anthrax letters.

The invention is exemplified by the following examples. These examples are intended to illustrate the invention, without limiting the scope thereof in any way.

EXAMPLE 1

This example describes an apparatus for detecting viable microorganisms in a fluid and use thereof. The apparatus can be used for real-time selection of microorganisms in a fluid or a fluid stream, based on the size of the microorganisms. This selection can then be followed by classification of the number of viable microorganisms per size class. The size and /or degradation curve of the detected fluorescence enables determining the species of the viable microorganisms.

The apparatus, represented by Figure 1, comprises an inlet for a sample that is connected to a series of coarse porous membrane separators with increasing narrowness. This enables size-separation of the microorganisms in the fluid. The outputs of the series of separators are individual streams of concentrated fluid, each stream comprising size-separated microorganisms. The first porous separator membrane

comprises large pores so that only large microorganisms are captured. The fluid that is flushed through the first porous separator membrane still comprises smaller microorganisms. These microorganisms will be captured from the fluid in the remaining membrane separating steps. The separators are connected to channels on the sample plate. Each channel is connected to the container comprising a phototautomeric compound and optionally an acid buffer. The apparatus further comprises a light source, such as a LED, and a camera. The camera is connected to a data processing unit, such as a computer.

10

The different streams of fluid to be tested for viable microorganisms are led into separate channels that are located in the sample immobilization area of in the apparatus. In Figure 1, this area is represented by the sample plate. Each channel is connected to the container comprising a phototautomeric compound. When a fluid stream enters its channel, it is mixed with the phototautomeric compound. Any viable microorganism in the fluid stream will absorb the phototautomeric compound and thus be activated.

15

The channels are then lighted by the apparatus' light source, such as a LED. The activated microorganisms will emit fluorescence, depending on the pH of the assay medium. The emitted light is filtered by an optical filter. The remaining emission spectrum is then detected by the camera, for example a CCD camera. The camera is connected to a computer. This enables the signal from the CCD camera to be read out by the computer. The computer may then predict the species of viable microorganisms that have been detected in the fluid streams, by translating both the changes that occur over time in the fluorescent signal and the size of the microorganism.

20
25
30

EXAMPLE 2

This example describes another apparatus for detecting viable microorganisms or spores in a fluid and use thereof. This apparatus provides real-time detection the number of viable microorganisms in a fluid or fluid stream. The form of the detected fluorescence spectrum enables differentiation between the detected microorganisms.

The apparatus, represented by Figure 2, comprises a porous membrane separator. The separator is connected to a sample inlet, connected to a channel on the sample plate. The channel is connected to the container comprising a phototautomeric compound. The apparatus further comprises a light source, such as a LED, and a camera. The camera is connected to a data processing unit, such as a computer. The channel on the sample plate can be replaced by an extended channel, provided a prolonged reaction time so that the apparatus can be used for detecting viable spores.

A fluid sample to be tested is first flushed through the porous membrane separator, enabling separation of the microorganisms from the fluid and separation of one size of microorganisms. After separation, the resulting fluid is led into a channel located in the apparatus' sample immobilisation area. This area is denoted in Figure 2 as "sample plate". Inside the channel, the fluid sample is mixed with the phototautomeric compound. Any viable microorganism in the fluid will absorb the phototautomeric compound and will thus be activated. To accelerate the mixing process, the apparatus may further comprise a micromixer that is located inside the channel.

The channel is then lighted by the apparatus' light source, such as a LED. The activated microorganisms will start emitting fluorescence. . The fluorescent light is filtered by an optical filter. The remaining emission

spectrum is then detected by the camera, for example a CCD camera. The camera is connected to a computer. This enables the signal from the CCD camera to be read out by the computer. The computer may then predict the number of viable microorganisms that have been detected in the fluid
5 sample, by translating both the changes that occur over time in the fluorescent signal and the size of the microorganisms.

The reacting channel located in the apparatus' sample immobilization area can be extended by adding channel extensions (see
10 Figure 2). The volume of these extensions can be calculated so that the total transit time will reflect or the time that is required to activate viable spores. Any fluid sample that passes through the channel may now also be tested for viable spores.

15 EXAMPLE 3

This example describes an apparatus for detecting viable microorganisms or spores in a gas, such as air, and use thereof. The apparatus provides real-time selection of microorganisms in a gas or gas
20 stream and consequent determination of the number of viable microorganisms. The size and/or degradation curve of the detected fluorescence enable determination of the species of the viable microorganisms.

25 The apparatus, represented by Figure 3, comprises an inlet for a sample, connected to a gas sampler. The gas sampler comprises a narrowing channel and is located on the sample plate. The gas sampler further comprises an activator compartment with porous walls. The activator compartment is connected to the container comprising a
30 phototautomeric compound. The apparatus further comprises a light source, such as a LED, and a camera. The camera is connected to a data processing unit, such as a computer.

The gas or gas stream to be tested for viable microorganisms is led through an inlet into an air sampler that is located in the sample immobilization area. This area is denoted in Figure 3 as "sample plate".

5 The gas sampler comprises at least two activator compartments that are connected to each other by means of a porous membrane. The first compartment is a channel through which the gas sample flows. The diameter of the channel decreases over the length of the channel. This results in an increase of the speed of the gas sample, and a decrease of the
10 average distance of the gas to the wall of the channel. Large microorganisms will be captured on the wall at the beginning of the channel, while smaller microorganisms will be captured at the wall at the end of the channel. The channel is connected to a container comprising an acid and a phototautomeric compound.

15

The wall of the channel comprises a thin layer of a liquid composition or a liquid composition-comprising microstructure, such as a gel. The liquid composition is acidic and comprises the phototautomeric compound. As the wall of the channel is connected to the container
20 comprising the phototautomeric compound by means of a porous membrane, evaporation of the composition due to the passing gas stream is prevented. The composition prevents reflux of the captured microorganisms into the gas sample and activates the viable microorganisms.

25

The channel is then lighted by the apparatus' light source, such as a LED. The activated microorganisms will start emitting fluorescence. The emitted radiation is filtered by an optical filter. The remaining emission spectrum is then detected by the camera, for example a CCD camera. The
30 apparatus preferably further comprises a light beam splitter. The camera is connected to a computer. This enables the signal from the CCD camera to be read out by the computer. The computer may then predict the

number of viable microorganisms that have been detected in the fluid sample, by translating both the changes that occur over time in the fluorescent signal and the size of the microorganisms.

5 Compared to the apparatus according to Example 4 this apparatus provides two advantages. First, it enables classification of the viable microorganisms based on size. Second, it enables sampling of a larger surface of the gel or composition so that a larger gas sample can be analysed. The apparatus is therefore highly suitable for high throughput
10 screening of non-thermic sterilised gasses, such as air from a clean room.

EXAMPLE 4

15 This example describes an apparatus according to the invention for detecting viable microorganisms or spores in a gas, such as air, or a fluid, and use thereof. It is a cost-effective and user-friendly apparatus providing either on-line or off-line detection of viable microorganisms.

20 The apparatus, represented in Figure 4, comprises an activator dosing system such as a spray nozzle. When performing on-line detection, a gas or fluid sample can be sprayed by the nozzle onto a sample immobilization area. In Figure 4, this area is denoted as "sample plate". The sample immobilization area is connected to a container comprising an acid and a phototautomeric compound.

25 When performing off-line detection, the activator dosing system is connected to a container comprising a phototautomeric compound. The acidic solution comprising the phototautomeric compound is then sprayed by the nozzle onto the sample immobilization area that comprises microorganisms captured from the gas, such as air in a room, or from the
30 liquid, such as blood from a human subject thought to be suffering from a microbial contamination. The sample immobilization area therefore may or may not be part of the apparatus.

The apparatus further comprises a light source, such as a LED, and a camera. The camera is connected to a data processing unit, such as a computer.

5 When performing on-line detection, a gas or fluid sample is sprayed by one or more nozzles onto the sample immobilisation area at relatively high speed. The sample immobilization area comprises a hydrophilic gel. Although not required, the area preferably is perpendicular to the flow direction of the nozzle(s). The sample immobilization area is connected to
10 a container comprising a phototautomeric compound in an acidic solution, and this solution is led into the gel that is located on the sample immobilization area. Microorganisms present in the sample are captured in the gel, due to both the positions of the sample immobilization area and the nozzle(s) and the relatively high speed of the sample when it is
15 sprayed from the nozzle(s). Captured viable microorganisms are then activated by the phototautomeric compound.

The gel is then lighted by the apparatus' light source, such as a LED. The activated microorganisms in the gel will start emitting fluorescence. The emitted radiation is filtered by an optical filter. The
20 remaining emission spectrum is then detected by the camera, for example a CCD camera. The apparatus preferably further comprises a light beam splitter. The camera is connected to a computer. This enables the signal from the CCD camera to be read out by the computer. The computer may then predict the number of viable microorganisms that have been detected
25 in the sample, by translating both the changes that occur over time in the fluorescent signal and the size of the microorganisms.

When performing off-line detection of a viable microorganism in a gas or fluid sample, these microorganisms can be captured on a separate
30 sample immobilization area such as a petri dish, a witness plate, an eppendorf cup or a swab. The sample immobilization area can be located

in a separate place, for example in a room to capture microorganisms from the air in that room, and then be placed into the apparatus.

Also the surface to be tested can be used as sample immobilization area. For example, a part of the surface to be tested is taken and placed
5 into the apparatus. Also, a part of the surface to be tested may be scanned by the apparatus. For example, the apparatus is used to scan a part of a table that may be contaminated by microorganisms.

EXAMPLE 5

10

With respect to the light source preferably UV illumination from a cheap light source, such as a LED is used. In this respect it is preferred to choose a phototautomeric compound that is excited with a wavelength well below
15 400 nm and that has an emission wavelength in the visual spectrum above 400 nm. As indicated above, suitable phototautomeric compounds can be chosen from Table 1, but especially preferred is 3-amino-2-naphtoic acid that has an excitation wavelength of 360 nm and an emission wavelength of 470 nm. The intensity of the emission light increases linearly with the intensity of the excitation light, up to an estimated saturation point at
20 about 1-2 kW/cm².

The primary purpose of selecting an excitation wavelength below the 400 nm boundary and an emission wavelength above this boundary is with respect to the signal to background ratio. The sensitivity of a silicon light-sensitive CCD array typically attenuates substantially below 400 nm (see
25 Fig. 6), thereby acting as a natural filter to reduce the background excitation light without losing any signal strength. This property of the CCD in combination with some additional filtering can make it possible to build a system with the excitation light source within the field of view of the detector without the resulting background overwhelming the signal.

30

EXAMPLE 6

A simple fluorescence microscope can be built for detecting micro-organisms according to the present invention with relatively few and inexpensive components: a USB or DSLR camera, a microscope objective and a UV light source (LED + lens). All these components are available from commercial sources. As shown in Fig. 7 further 'obstacles' for the emission light will be formed by the sterile filter on which the micro-organisms are trapped and by the glass holder that holds the sterile filter. The filter, the glass, the microscope objective and the camera itself have limited UV transparency, so they will act as a UV filter. The background UV signal will be further attenuated as a result of the sensor array's relative insensitivity to wavelengths below 400 nm. Any UV emitting LED may be used, the 360 nm UV LED as depicted in Figs. 7 and 8 is just for illustration.

The advantages of a set-up according to Figure 7 are:

- inexpensive and reliable: it is composed of relatively few optical component
- high resolution and light collection efficiency
- adjustable focus and magnification
- requirements for price and time-resolved measurements are easily met

EXAMPLE 7

Another embodiment according to the present invention is shown in Figure 8. In that case the imaging of the sample is performed directly on a CCD or CMOS chip, which requires even less components: the chip of a USB or DSLR camera and a UV light source. Again here, the sterile filter and the camera have limited UV transparency but high visual light transparency thus they will act as a UV filter. The spatial resolution and

sensitivity of the system of Fig. 7 depend on the distance between the sample and the chip. To be feasible, this distance should be about 50-200 μm , preferably about 100 μm , which is achievable with minimum component layers. Hence the inherent UV filtering properties of the silicon
5 detector become more important.

The advantages of this specific embodiment are:

- because of the few and cheap optical components it is inexpensive and reliable
- 10 - very high light collection efficiency
- requirements for price and time-resolved measurements can be met
- large active area (13*18 mm for DSLR camera chip), thus large field of view.

Claims

1. Apparatus for detecting at least one viable microorganism or spore in a sample, comprising:
- 5 a) an inlet for said sample,
b) a sample immobilization area,
c) a container comprising a composition comprising a phototautomeric compound,
d) a light source, and
10 e) a detection unit.
2. The apparatus according to claim 1, wherein said sample immobilization area is selected from the group consisting of a plate, a filter, a container, a surface and one or more lenses.
- 15 3. The apparatus according to any one of claims 1 to 2, wherein said phototautomeric compound is selected from the group consisting of salicylic acid, 2-hydroxy-1-naphtoic acid, 1-hydroxy-2-naphtoic acid, 4-amino salicylic acid, 5-amino salicylic acid, gentisic acid, 4-hydroxy
20 salicylic acid, 3-amino-2naphtoic acid, o-hydroxycinnamic acid, 2-hydroxy-dibenzofuran-3-carboxylic acid (S350729), 6-amino-1,3-dimethyl-2-oxo-2,3-dihydro-1H-benzimidazole-5-carboxylic acid, 5-(2-ethyl-butylamino)-2-hydroxy-benzoic acid, 2-hydroxy-5-[(tetrahydro-furan-2-carbonyl)-amino]-benzoic acid, 7-amino-2,3-dihydro-benzo[1,4]dioxine-6-carboxylic acid and
25 2-hydroxy-5-tetrazol-1-yl-benzoic acid.
4. The apparatus according to any one of the preceding claims, wherein said apparatus further comprises at least one separator, preferably wherein said at least one separator is a porous membrane
30 separator, more preferably wherein said porous membrane separator is a gas sampler.

5. The apparatus according to any one of the preceding claims,
wherein said sample immobilization area is connected to said container.

6. The apparatus according to any one of the preceding claims,
5 wherein said light source is a monochromatic light source, preferably
wherein said monochromatic light source is a light emitting diode (LED).

7. The apparatus according to any one of the preceding claims,
wherein said detection unit is an optical detection unit.

10

8. The apparatus according to claim 7, wherein said optical detection unit
is a camera, preferably wherein said camera is a Charge Coupled Device
(CCD) camera, more preferably a USB or DSLR (Digital Single Lens
Reflex) camera.

15

9. The apparatus according to claim 7, wherein said optical detection
unit is a chip, preferably a CCD or a CMOS chip.

10. The apparatus according to any one of the preceding claims,
20 wherein said apparatus further comprises an optical filter, preferably a
UV filter.

11. The apparatus according to any one of the preceding claims,
wherein said apparatus further comprises a light beam splitter.

25

12. The apparatus according to any one of the preceding claims,
wherein said detection unit is connected to a data processing unit,
preferably wherein said data processing unit is a computer.

30 13. Use of an apparatus according to any one of the preceding claims for
detecting at least one viable microorganism in a sample, preferably
wherein said microorganism is selected from the group consisting of

bacteria, fungi, yeasts, algae, cell cultures of plant cells and cell cultures of animal cells.

14. Use of an apparatus according to any one of claims 1 to 12 for
5 detecting at least one viable spore in a sample, preferably wherein said spore is selected from the group consisting of a bacterial spore, a fungal spore or an algae spore.

15. Use according to claims 13 or 14, wherein said sample is selected
10 from the group consisting of a gas, a fluid, an aqueous solution, an emulsion, a dispersion, a liquid culture medium, a dissolved culture medium, a dissolved soil, a dairy product, a food product, blood, saliva, sputum, mucus, faeces and urine.

P88650PC00 Figures

Figure 1

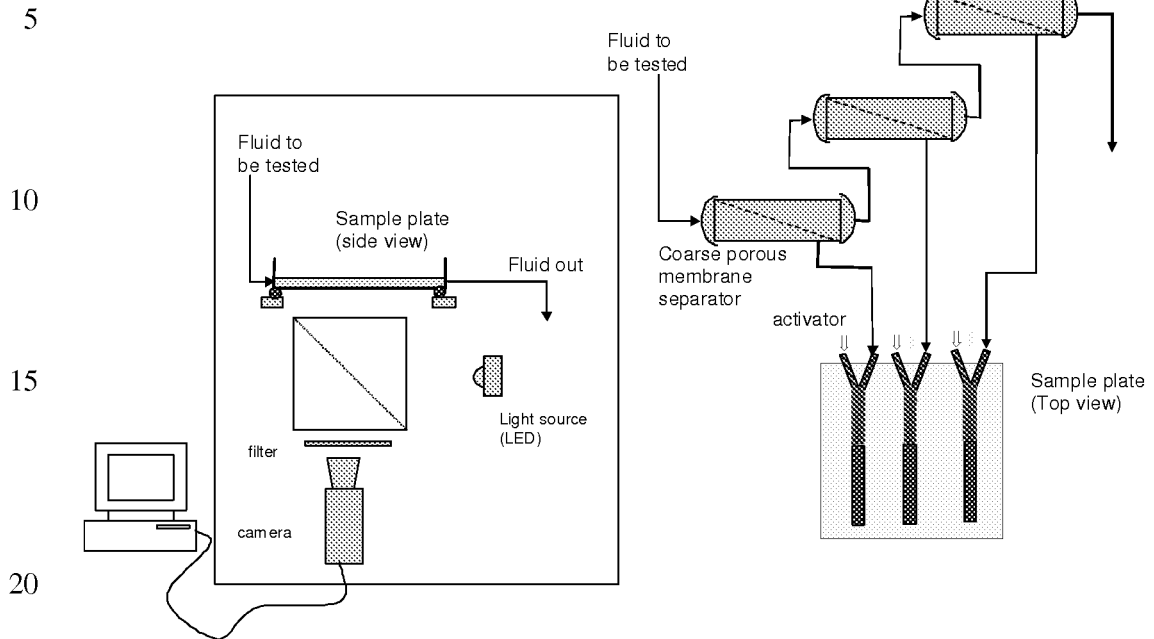

Figure 2

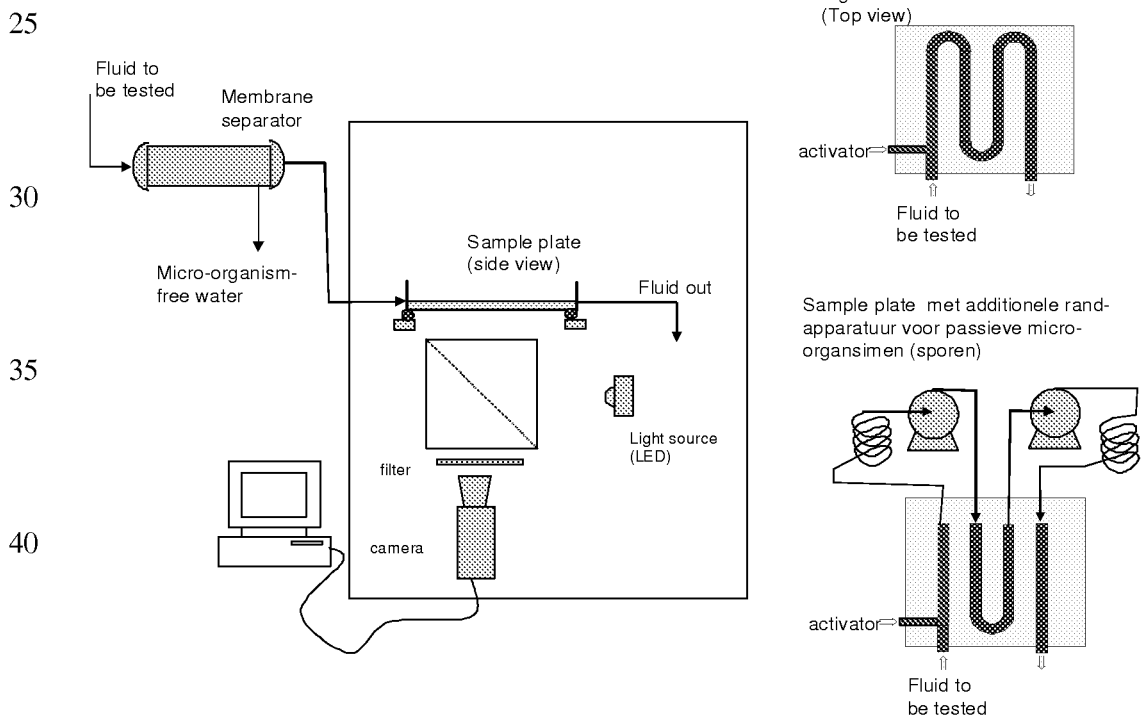
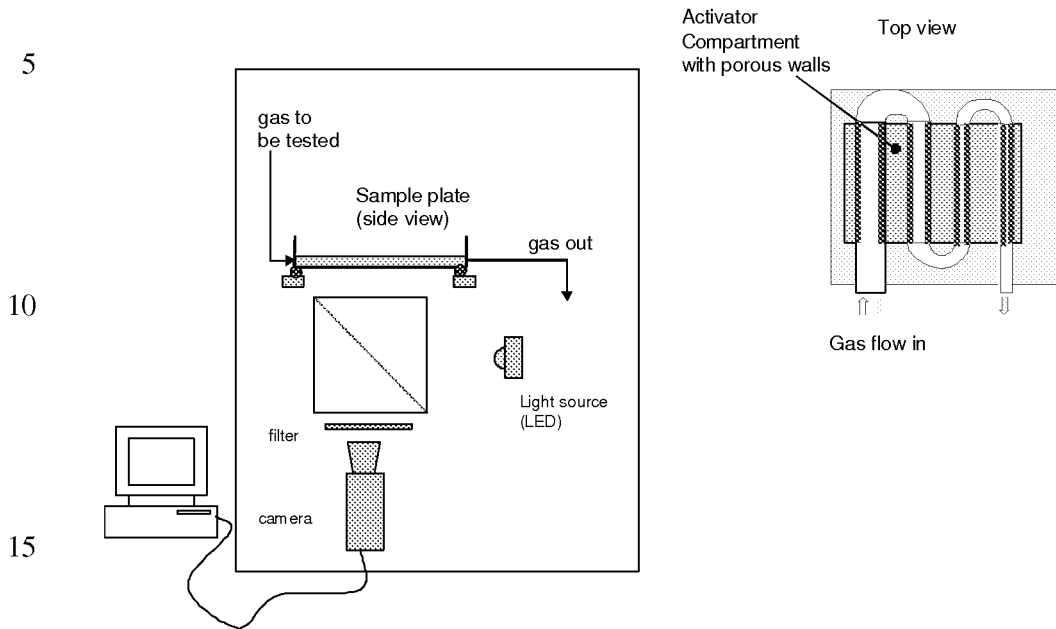

Figure 3



20

Figure 4

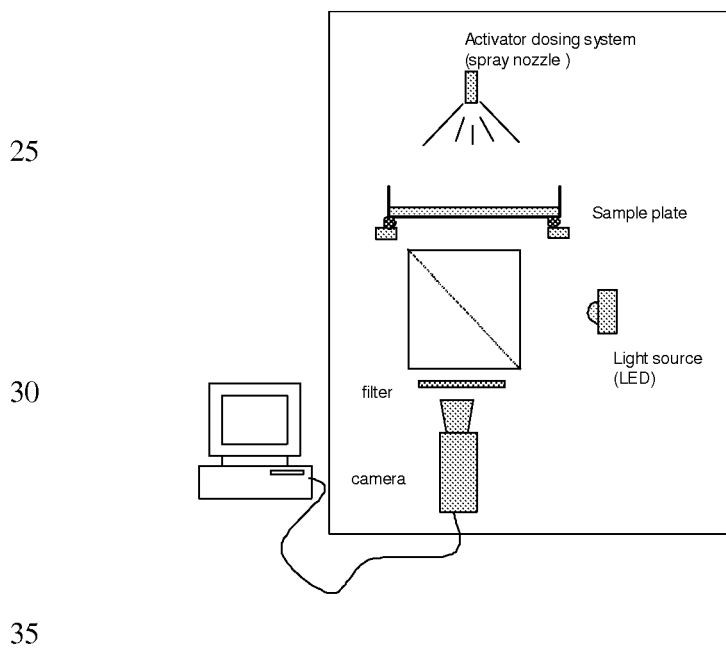

Figure 5

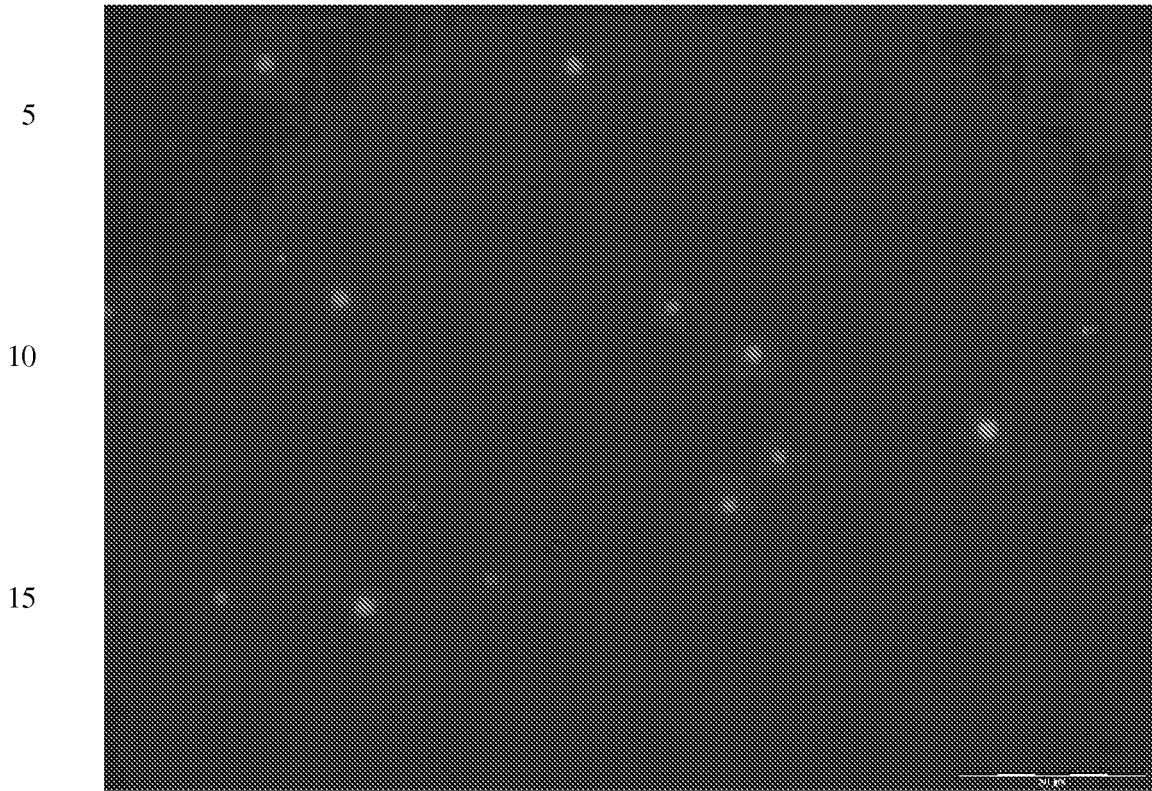

Figure 6

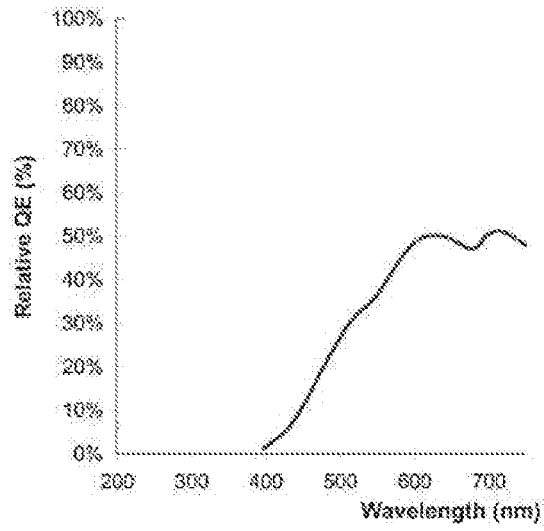

Figure 7

5

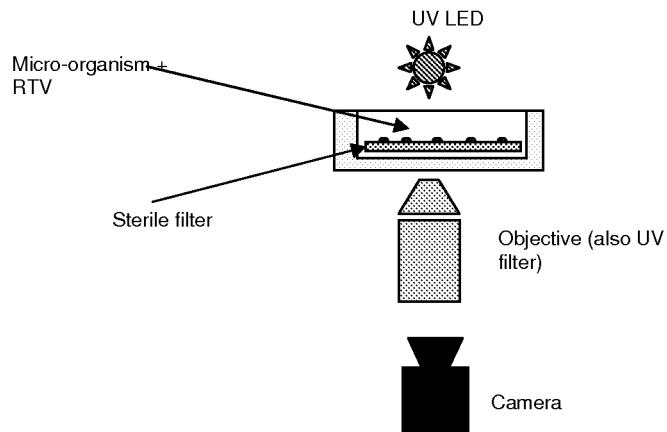

Figure 8

