



VU Research Portal

Production of narrowband tunable extreme-ultraviolet radiation by noncollinear resonance-enhanced four-wave mixing

Hannemann, S.; Hollenstein, U.; van Duijn, E.J.; Ubachs, W.M.G.

published in

Optics Letters
2005

DOI (link to publisher)

[10.1364/OL.30.001494](https://doi.org/10.1364/OL.30.001494)

document version

Publisher's PDF, also known as Version of record

[Link to publication in VU Research Portal](#)

citation for published version (APA)

Hannemann, S., Hollenstein, U., van Duijn, E. J., & Ubachs, W. M. G. (2005). Production of narrowband tunable extreme-ultraviolet radiation by noncollinear resonance-enhanced four-wave mixing. *Optics Letters*, 30(12), 1494-1496. <https://doi.org/10.1364/OL.30.001494>

General rights

Copyright and moral rights for the publications made accessible in the public portal are retained by the authors and/or other copyright owners and it is a condition of accessing publications that users recognise and abide by the legal requirements associated with these rights.

- Users may download and print one copy of any publication from the public portal for the purpose of private study or research.
- You may not further distribute the material or use it for any profit-making activity or commercial gain
- You may freely distribute the URL identifying the publication in the public portal ?

Take down policy

If you believe that this document breaches copyright please contact us providing details, and we will remove access to the work immediately and investigate your claim.

E-mail address:

vuresearchportal.ub@vu.nl

Production of narrowband tunable extreme-ultraviolet radiation by noncollinear resonance-enhanced four-wave mixing

S. Hannemann, U. Hollenstein, E.-J. van Duijn, and W. Ubachs

Laser Centre, Department of Physics and Astronomy, Vrije Universiteit, De Boelelaan 1081,
1081 HV Amsterdam, The Netherlands

Received December 16, 2004

Fourier-transform-limited extreme-ultraviolet (XUV) radiation (bandwidth $\lesssim 300$ MHz) tunable around 91 nm is produced by use of two-photon resonance-enhanced four-wave mixing on the Kr resonance at $94\,093\text{ cm}^{-1}$. Noncollinear phase matching ensures the generation of an XUV sum frequency $2\omega_1 + \omega_2$ that can be filtered from auxiliary laser beams and harmonics by an adjustable slit. Application of the generated XUV light is demonstrated in spectroscopic investigations of highly excited states in H_2 and N_2 . © 2005 Optical Society of America

OCIS codes: 190.4380, 140.7240, 300.6400.

Nonlinear optical schemes for the production of narrowband and tunable extreme-ultraviolet (XUV) radiation, either through third-order harmonic conversion or resonant sum- and difference-frequency mixing, date back to the 1970s and 1980s. A description of phase matching and properties of the $\chi^{(3)}$ nonlinear susceptibility tensor was given by Bjorklund.¹ Although Hilber *et al.*² performed pioneering studies of the resonance enhancement effect by two-photon transitions in noble gases, it was later found that the $4p^6 - 5p[1/2]_0$ transition in Kr gas is most effective in enhancing the XUV yield.^{3,4} The replacement of grating-based pulsed lasers by Fourier-transform-limited lasers, generally in the form of pulsed-dye amplifiers (PDAs) opened the possibility of generating ultranarrowband XUV radiation^{5,6} even at wavelengths as short as 58 nm.⁷ In applications in which the generated XUV beam needs to be separated from the incident laser beams, as well as from the auxiliary harmonic and mixed frequencies, usually a grating is employed, with the drawback of intensity loss of an order of magnitude or more. Here we demonstrate that phase matching in a noncollinear beam configuration can combine the advantage of resonance enhancement with the production of a separated XUV beam, filtered geometrically by the insertion of an adjustable slit. The scheme is somewhat similar to that of BOXCARS, which is applied for geometric filtering of a generated beam in coherent anti-Stokes Raman spectroscopy.⁸

All the measurements are performed in a three-chamber differentially pumped vacuum setup that has been described in connection with third-harmonic generation⁹ (THG) and fifth-harmonic generation.⁷ Here we produce tunable XUV light by mixing the output of two different lasers in a pulsed jet of Kr. One provides the resonant light ω_1 for the Kr $4p^6 - 5p[1/2]_0$ two-photon transition at $94\,093\text{ cm}^{-1}$; the other supplies the tunable component ω_2 in a resonance-enhanced four-wave-mixing scheme. For all the results presented, the sum frequency $2\omega_1 + \omega_2$ is used, and the repetition rate is 10

Hz. To filter out undesired wavelengths, a simple geometric scheme is applied as depicted in Fig. 1. Aligning the resonant light ω_1 at 212 nm and the tunable output ω_2 of the second laser to overlap in the Kr jet under an angle of approximately 80 mrad allows phase-matching conditions for the sum frequency $2\omega_1 + \omega_2$, the difference frequency $2\omega_1 - \omega_2$, and the third harmonic $3\omega_1$ to be fulfilled at angles as displayed in Fig. 1. This geometry allows us to block all unwanted wavelengths with a slit that is adjustable in width and position and located between the frequency-mixing chamber and the downstream application zone.

For the production of the resonant light at 212 nm a novel narrowband laser system, as schematically shown in Fig. 2, is used. A gain-switched injection-seeded Ti:sapphire (Ti:Sa) oscillator, pumped by the second-harmonic output of a Q-switched Nd:YAG laser (Spectra-Physics Quanta Ray GCR-3), produces nearly Fourier-transform-limited pulses at a wavelength of $\lambda = 850.222\text{ nm}$ with a typical duration of 15 ns and a bandwidth of 40 MHz. The output of the pulsed oscillator is subsequently enhanced to 15 mJ

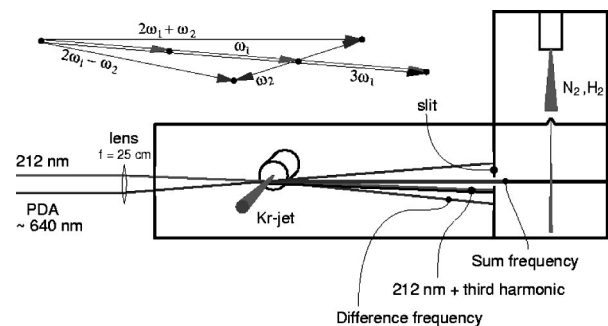

Fig. 1. Schematic view of the beam alignment and the resulting directions for the different vacuum ultraviolet wavelengths. In the Kr gas jet the sum frequency $2\omega_1 + \omega_2$, difference frequency $2\omega_1 - \omega_2$, and third-harmonic $3\omega_1$ are produced. A phase-matching diagram is included in the upper left. The slit, adjustable in position and width, filters the XUV beam at frequency $2\omega_1 + \omega_2$.

Table 1. Observed Transition Frequencies for P and R Branch Lines in the $H_2B^1\Sigma_u^+-X^1\Sigma_g^+$ (19, 0) Lyman Band^{a,b}

J	$P(J)$	Δ_1^c	Δ_2^d	Δ_3^e	Δ_4^f
1	109 653.067(20)	-0.17	0.10	-0.01	-0.05
2	109 436.712(20)	-0.23	-0.34	-0.17	-0.07
3	109 124.687(40)	-0.16	-0.25	0.22	-0.12
J	$R(J)$	Δ_1	Δ_2	Δ_3	Δ_4
0	109 791.089(20)	-0.08	-0.09	-0.14	-0.07
1	109 711.738(20)	-0.14	0.18	-0.10	-0.10
2	109 534.895(20)		0.30	-0.10	0.02
3	109 264.271(20)	-0.13	0.21	0.02	-0.03

^a Δ_i represent deviations from previous investigations (present minus previous).

^bAll values given in cm^{-1} .

^cDifference with the results of Hinnen *et al.*¹⁰

^dDifference with results of Namioka.¹²

^eDifference with results of Abgrall *et al.*¹³

^fDifference with the calculated line positions resulting from the term levels of Abgrall *et al.*¹⁴ and the ground-state level energies from Jennings *et al.*¹⁵

in a bow-tie Ti:Sa amplifier and nonlinearly upconverted by two consecutive type I second-harmonic generation stages made from β -barium borate (BBO) crystals cut at appropriate phase-matching angles. The final output at 212 nm is typically 0.5 mJ with a bandwidth of 80 MHz. The injection-seeding light is provided by an external grating diode laser system (Toptica DL 100). The output frequency of the diode laser is locked with a computer-controlled feedback loop. The computer continuously acquires the wavelength of the seed light from an ATOS wavelength-meter and controls the output wavelength of the diode laser by adjusting the angle of the feedback grating with a piezoactuator. The accuracy of this locking scheme is restricted by the accuracy of the wavelength-meter, which is 0.002 cm^{-1} in the near-infrared. Since the fourth-harmonic ω_1 is used to drive the two-photon transition in Kr, the error multiplies by 8 to 0.016 cm^{-1} in the XUV. It should be noted that under conditions of $f=25 \text{ cm}$ focusing of the ω_1 beam the two-photon resonance in Kr broadens to approximately 1 cm^{-1} . In view of the small bandwidth of the ω_1 laser ($\approx 0.003 \text{ cm}^{-1}$ at 212 nm), the resulting XUV frequency and bandwidth are determined by the frequency and bandwidth of the laser, not by the resonance.

Tunable frequency ω_2 in the wavelength range of 630–650 nm is provided by a PDA consisting of three amplification stages pumped by the second-harmonic output of a Q-switched Nd:YAG laser (Spectra-Physics GCR-4) and delivering $\approx 20 \text{ mJ/pulse}$. The cw seeding light is generated by a ring dye laser (Spectra-Physics 380) running on 4-dicyanomethylene-2-methyl-6-(*p*-dimethylaminostyryl)-4*H*-pyran (DCM) and pumped by the second harmonic of a diode-pumped Nd:YVO₄ laser (Spectra-Physics Millennia X). Absor-

ption frequency calibration of the PDA (bandwidth of $\approx 100 \text{ MHz}$) is realized through iodine saturation spectroscopy and a stabilized etalon yielding an accuracy in ω_2 (including frequency chirp effects in the PDA) better than 0.001 cm^{-1} . The intensity of the XUV output was not measured directly. From measurements of signal strengths in photoionization studies (see below) and comparison with previous detection schemes using THG,^{9–11} photon densities in excess of 10^9 photons per pulse are estimated.

To demonstrate the capabilities of the source, the tunable narrowband XUV radiation is applied in crossed-molecular-laser-beam spectroscopic experiments on highly excited states in H_2 and N_2 . Spectral lines are recorded by tuning the XUV source into resonance with an excited state of the molecule, which is then subsequently ionized (a $1+1'$ photoionization scheme) by an auxiliary laser beam—here the residual second harmonic of the Ti:Sa laser at 425 nm is taken—incident from the rear side of the interaction chamber. The signal is monitored by detection of ions on an electron multiplier after pulsed-field extraction, time-of-flight mass separation, and time gating of the ions produced in photoionization. We reduce Doppler effects (broadening and shifts) by producing a collimated molecular beam by means of a skimmer and aligning it perpendicularly to the resulting ($2\omega_1 + \omega_2$) XUV beam. We accomplish the latter by adjusting the angles between incident laser beams and by addressing shifts between spectral lines in pure H_2 beams and seeded H_2/Ar beams.

For H_2 , measurements are performed on the $B^1\Sigma_u^+-X^1\Sigma_g^+$ (19,0) Lyman band; results for the line positions after averaging over various recordings and assessment of the uncertainty budget (dominated by the uncertainty in ω_1) are listed in Table 1. An error of 0.020 cm^{-1} is estimated, except for the $P(3)$ line for which no saturated I_2 line was available in the calibration procedure for ω_2 ; here the calibration relied on a wavelength meter. For all the H_2 lines observed

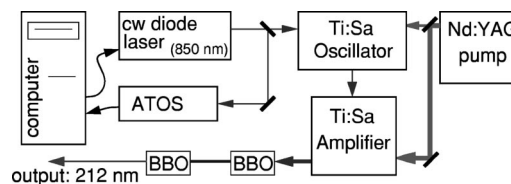

Fig. 2. Laser setup for the resonant light at 212 nm. In a computer-controlled feedback loop the diode injection seed is locked to a preset value of an ATOS wavelength meter.

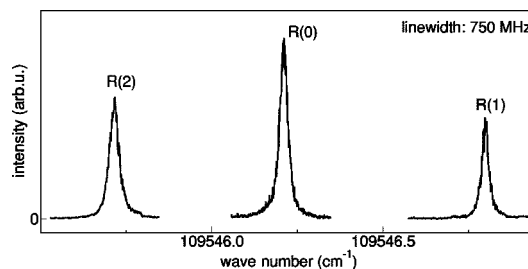

Fig. 3. $1+1'$ photoionization recording of the R (0–2) lines of the $b^1\Sigma_u^+-X^1\Sigma_g^+$ (8, 0) band in N_2 .

Table 2. Observed Transition Frequencies and Linewidths Γ_{obs} for Lines in the $b^1\Pi_u-X^1\Sigma_g^+$ (12, 0) Band and the $b'^1\Sigma_u^+-X^1\Sigma_g^+$ (8, 0) Band in N_2^a

	Line		Position	Δ^b		Γ_{obs}
	$b-X$	(12,0)	$Q(1)$	109 829.483(30)	-0.10 ^c	0.058(5)
	$b'-X$	(8,0)	$R(1)$	109 546.800(20)	-0.23, ^d	0.023(3)
	$b'-X$	(8,0)	$R(0)$	109 546.211(20)	-0.19, ^d	0.026(3)
	$b'-X$	(8,0)	$R(2)$	109 545.712(20)	-0.26, ^d	0.025(3)

^aAll values given in cm^{-1} ^bDeviations from results of previous investigations (present minus previous).^cUbachs *et al.*¹⁶^dCarroll *et al.*¹⁷^eRoncin *et al.*¹⁸

in this work a linewidth of ≈ 600 – 700 MHz was observed. This is the same width as obtained in studies investigating H_2 spectral lines with narrowband XUV produced through direct THG. From a comparison with results from Ref. 11 we estimate that the bandwidth of the $2\omega_2 + \omega_1$ XUV beam is ≈ 300 MHz. The additional broadening is due to residual Doppler broadening in the slightly divergent high-velocity pulsed molecular beam. In Table 1 the observed transition frequencies are compared with previous results from XUV laser spectroscopy, however, at larger bandwidths,¹⁰ from old classical spectroscopic studies¹² and from a recent highly accurate classical study from the Meudon group.^{13,14} Very accurate data result from Meudon excited-state level energies¹⁴ combined with ground-state level energies from far-infrared spectra;¹⁵ these data are off by only -0.06 cm^{-1} from the present data, which represent the highest accuracy frequencies on the (19,0) Lyman band. These lines could be included in analyses of quasar data aiming at uncovering a possible variation of the proton-to-electron mass ratio over cosmological time.¹¹

XUV spectroscopic investigations in N_2 were performed as well. A single rotationally resolved $Q(1)$ line in the $b^1\Pi_u-X^1\Sigma_g^+$ (12, 0) band was recorded, for which a linewidth of $\Gamma_{\text{obs}} = 1.74(15)$ GHz was observed. After deconvolution of contributions from Doppler and laser source broadening a value results for the natural width, associated with the predissociation rate of the excited state; an excited lifetime of 105(25) ps is estimated. In previous laser-based studies with larger bandwidths¹⁶ a natural lifetime broadening effect could not be discerned. In addition, the $b'^1\Sigma_u^+-X^1\Sigma_g^+$ (8, 0) band was recorded, for the first time to our knowledge resolving the band head section, as shown in Fig. 3. The obtained width of 750 MHz is somewhat broader than the expected instrument width and hence indicates predissociation of the $b'^1\Sigma_u^+, v=8$ upperstate, but at a lower rate than for $b^1\Pi_u, v=12$. In Table 2 results on calibrated frequencies and observed widths are listed. For the measured transition frequencies a comparison is made with values obtained from previous studies.^{17,18}

In conclusion, narrowband XUV generation using a noncollinear phase-matching scheme for resonance-

enhanced four-wave mixing is demonstrated and applied in spectroscopic measurements on highly excited states of H_2 and N_2 . The accuracy of the obtained results is dominantly limited by the calibration of the ω_1 frequency laser and could be improved considerably when a better calibration procedure becomes available.

The authors thank J. P. Sprengers and E. Reinhold (Laser Centre Vrije Universiteit), as well as F. Merkt (ETH Zürich), for helpful discussions. We gratefully acknowledge financial support from the Netherlands Foundation for Fundamental Research of Matter. S. Hannemann's e-mail address is sandro@nat.vu.nl.

References

1. G. C. Bjorklund, IEEE J. Quantum Electron. **QE-6**, 287 (1975).
2. G. Hilber, A. Lago, and R. Wallenstein, J. Opt. Soc. Am. B **4**, 1753 (1987).
3. J. P. Marangos, N. Shen, H. Ma, M. H. R. Hutchinson, and J. P. Connerade, J. Opt. Soc. Am. B **7**, 1254 (1990).
4. K. Miyazaki, H. Sakai, and T. Sato, Appl. Opt. **28**, 699 (1989).
5. E. Cromwell, T. Trickl, Y. T. Lee, and A. H. Kung, Rev. Sci. Instrum. **60**, 2888 (1989).
6. U. Hollenstein, H. Palm, and F. Merkt, Rev. Sci. Instrum. **71**, 4023 (2000).
7. K. S. E. Eikema, W. Ubachs, W. Vassen, and W. Hogervorst, Phys. Rev. A **55**, 1866 (1997).
8. A. Eckbreth, Appl. Phys. Lett. **32**, 421 (1978).
9. W. Ubachs, K. S. E. Eikema, W. Hogervorst, and P. C. Cacciani, J. Opt. Soc. Am. B **14**, 2469 (1997).
10. P. C. Hinnen, W. Hogervorst, S. Stolte, and W. Ubachs, Can. J. Phys. **72**, 1032 (1994).
11. W. Ubachs and E. Reinhold, Phys. Rev. Lett. **92**, 101302 (2004).
12. T. Namioka, J. Chem. Phys. **40**, 3154 (1964).
13. H. Abgrall, E. Roueff, J.-Y. Roncin, and J.-L. Subtil, Astron. Astrophys. Suppl. Ser. **101**, 273 (1993).
14. H. Abgrall, E. Roueff, J.-Y. Roncin, and J.-L. Subtil, J. Mol. Spectrosc. **157**, 512 (1993).
15. D. E. Jennings, S. L. Bragg, and J. W. Brault, Astrophys. J. **282**, L85 (1984).
16. W. Ubachs, K. S. E. Eikema, and W. Hogervorst, Appl. Phys. B: Photophys. Laser Chem. **57**, 411 (1993).
17. P. K. Carroll, C. P. Collins, and K. Yoshino, J. Phys. B **3**, L127 (1970).
18. J.-Y. Roncin, J.-L. Subtil, and F. Launay, J. Mol. Spectrosc. **188**, 128 (1998).