

Modelling of DPF Regeneration using Microwave Energy

Nadarajah Manivannan^{*1}, Nehemiah Alozie², David Brennan¹, Maysam Abbod¹, Lionel Gannippa², Wamadeva Balachandran¹

¹ Department of Electronic and Computer Engineering, Brunel University, Uxbridge, UK

² Department of Mechanical, Aerospace and Civil Engineering, Brunel University, Uxbridge, UK

*Corresponding author: Center for Electronic Systems Engineering (CESR),
Institute of Environment, Health and Society, Department of Electronic and Computer Engineering,
Brunel University, Uxbridge, UB8 3PH, UK.
Email: Nadarajah.manivannan@brunel.ac.uk

Abstract:

A set of experimental results of microwave regeneration of DPF using an existing microwave cavity system is presented in this paper along with simulation results from the COMSOL based FEM model. Furthermore, a new microwave cavity for the regeneration of DPF regeneration was proposed and COMSOL FEM model was used to investigate heating properties of the Silicon Carbide (SiC) based DPF. Electric field profile and thermal profile of the microwave cavity and DPF was established for various dimensions of microwave cavity for a given DPF size and the results were investigated. Microwave frequency used in the experiments and COMSOL simulations was 2.45GHz. It was found a cylindrical cavity (diameter of 153mm and length of 533mm) gives a set of optimal dimensions for the regeneration of a commercial DPF (143mm (diameter) x 183mm (length) in terms of near homogenous electric field distribution.

Keywords: Microwave Regeneration, DPF Regeneration, COMSOL FEM Modelling, Soot Removal and Emission Control.

1. Introduction

Diesel Particulate Filter (DPF) is a well-established technique in soot capturing from diesel engines, in particular, in land transport such as cars, vans and trucks [1]. DPF requires regular regeneration to remove the captured soot and it is generally achieved passively by exhaust gas with increased temperature [2]. However, it has been shown that microwave (MW) energy for regeneration is a promising technology [3]

for a number of reasons; rapid heating, instantaneous penetration of microwave into dielectric materials and lower soot combustion temperature.

In this paper a set of experimental results in relation to the DPF regeneration are presented and COMSOL FEM model of the cavity was developed and simulated to understand the electric field (Efield) distribution of the cavity. The thermal hot spots observed in the experiments are compared with simulation results of the COMSOL FEM model. These experiments and simulations are described in section 2.

A new microwave cavity (interchangeably referred to as 'the cavity') is proposed for a given dimension of a DPF in order to minimize the heat loss and better spread of heating within the DPF. A generic COMSOL model was developed to understand the thermal and Efield profile within the DPF. A further set of COMSOL simulations were performed in order to understand the influence of the length of the proposed cavity. These simulations also used to identify the right location for the placement of DPF of given dimensions. The proposed microwave cavity and the development of COMSOL model are presented in section 3. Section 4 presents the results and discussion of the simulation performed using the COMSOL model. Finally conclusions are drawn in section 5.

2. DPF Regeneration using MW

The microwave cavity set-up used in the DPF regeneration is shown in Fig. 1 [2]. As shown, MW energy is launched into the cavity

through two wave guides. The two magnetrons are connected to their respective waveguides through isolators and tuners. Isolator basically separates the forward MW power and reflected MW power to prevent the magnetrons getting damaged due to the reflected MW power. Isolator transfers the reflected power into the water load, where the MW power gets dissipated. Tuner is placed between the isolator and the wave guide and it allows the impedance of the applicator to be matched with the impedance of the source so that maximum MW energy is transferred to the applicator. In our case applicator is the microwave cavity.

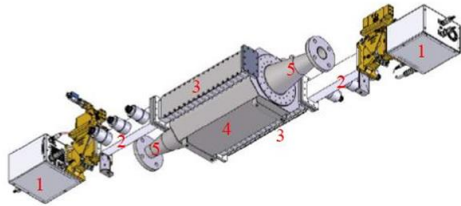

Figure 1: Existing microwave cavity with two magnetrons; (1) magnetron generators (magnetron source, measurements, and cooling), (2) stub tuners, (3) slotted waveguides, (4) microwave cavity and (5) air inlet/outlet

Using the microwave cavity shown in Fig. 1, soot filled DPF was regenerated and the summary of the results are given in Table 1. 2kW of microwave power was launched into the cavity where DPF was oriented such a way the front face of the DPF was facing the slots in the waveguide. This was the location found to be efficient in terms of rapid heating. Other orientations were also attempted and it took relatively longer time to get the required DPF temperature.

Table 1: Summary of a DPF regeneration experiment

Mass of the SiC DPF	1830g
Mass of soot removed	10 g
Total MW energy supplied	3840kj
Temperature rise	550°C
Energy used by DPF	755kj
% efficiency of the MW system	20%

Fig. 2 shows the pictures of DPF at three stages (Original, Soot filled and while in the microwave cavity). As shown in the Fig. 3(C) the when DPF was in the MW field for some

time DPF has generated hot-spot in it's the front face. The reason for the hot spot was due to the high electric field intensity at those regions generating higher temperature. Note that DPF was insulated using Fiberfrax Durablanket, which is made out of SiO₂ (~50%) and Al₂O₃ (~50%) and is transparent to MW and provides an excellent thermal insulation

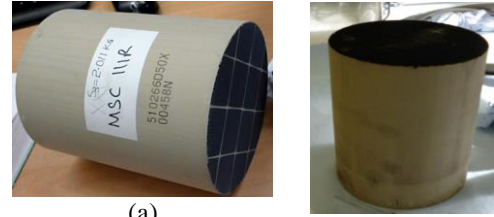

(a)

(b)

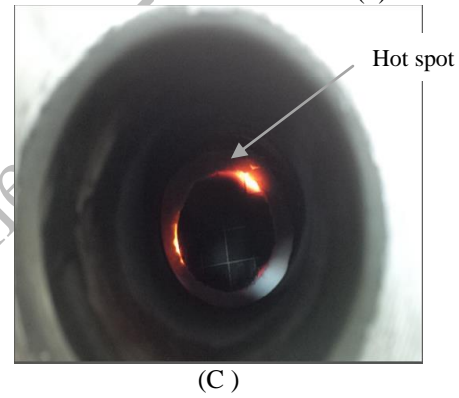

(C)

Figure 2: DPF at various stages (a) Clean DPF (b) Soot filled DPF and (C) DPF in microwave filed with glow.

COMSOL model was used to verify this fact. The simplified COMSOL geometry is of the microwave set-up (Fig.1) is shown in Figure 3. As shown, microwave energy is injected through the waveguides in opposite direction into the cavity. The magnetrons and stub tuners are ignored as they do not influence the electric filed patterns in the waveguide and cavity. Each waveguides have six slots inclined at 190 to the horizontal to have maximum microwave energy injection.

A number of simulations were performed and the following equation was solved in frequency domain by COMSOL to determine the electric field distribution in the waveguide and the cavity:

$$\nabla \times \mu_r^{-1}(\nabla \times \mathbf{E}) - K_0^2 \left(\epsilon_r - \frac{j\sigma}{\omega\epsilon_0} \right) \mathbf{E} = 0 \quad (1)$$

Where μ_r - permeability of the medium, ϵ_0 - permittivity of the medium, \mathbf{E} - electric field vector, σ - density of the medium, K_0 – wave number. Walls of the wave guide and cavity were assumed to be perfect conductors and the following boundary condition was applied:

$$\mathbf{n} \times \mathbf{E} = 0 \quad (2)$$

where \mathbf{n} – normal vector to the walls.

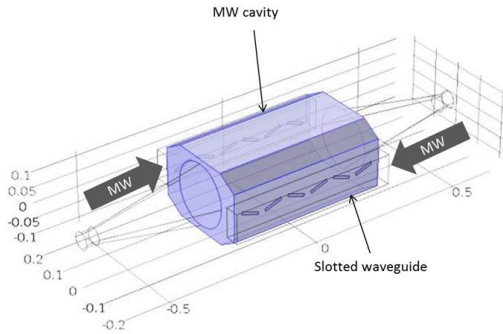

Figure 3: Simplified COMSOL geometry of microwave cavity as shown in Fig. 1 (dimensions shown are in m).

The two sets of results from a simulation are shown in Fig.4, where electric field pattern can be seen in a plane (zx) when $y=0$ {Fig. 4(c)} and a 3D iso-surface plot {Fig. 4(b)}. These simulations were performed when microwave power was set to 500W ($\times 2$) and frequency was 2.45GHz. From these figures and the Fig. 2(c), it can be verified the high intense electric field locations have generated the hot spot in the DPF.

It is clear from the experimental results that efficiency of the microwave system is very low (20%) and it is largely due to the fact electric field distribution within the cavity used is not homogenous and hence thermal profile of the DPF is not also very uneven across the DPF. The Thermal power generated within the DPF is given by the following formula,

$$P = 2\pi f \epsilon_0 \epsilon'' E_{rms}^2 V \quad (3)$$

where, P is power dissipated in the material [W/m³], f is microwave frequency [Hz], ϵ_0 is electric permittivity of vacuum [F/m], E_{rms} is root mean square value of electric field strength with in the material, V is the

volume of the material and ϵ'' is dielectric loss factor and given by $\epsilon'' = \sigma / (2\pi f)$.

E_{rms} depends on the power of magnetrons used, the dielectric constant of the material (ϵ') and geometry of the microwave system.

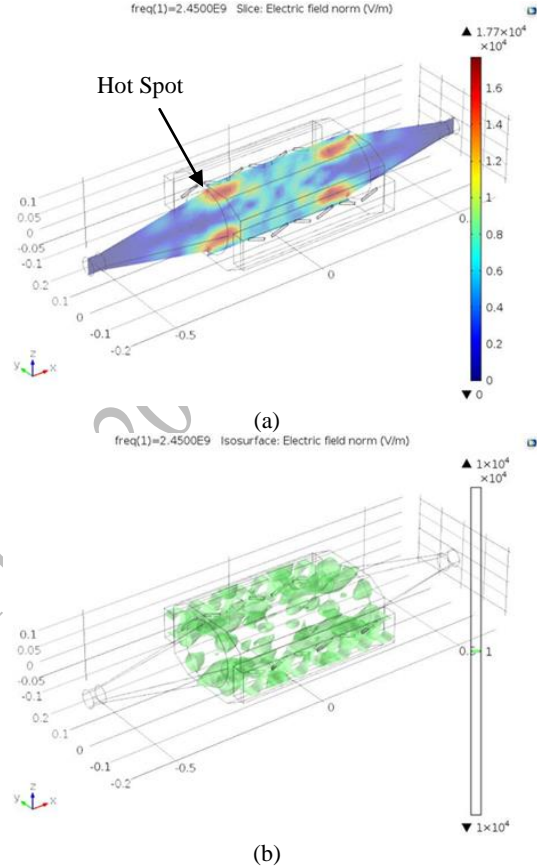

Figure 4: Electric field distribution (V/m) (a) ZX plane (b) 3D Iso-surface plot

3. A New Proposed Microwave Cavity

A new microwave cavity is proposed such a wave DPF nicely fits into the cavity. The COMSOL geometry of the proposed cavity is shown in Fig. 5. Microwave is injected through a rectangular waveguide and cavity is shaped to be cylindrical to allow the DPF fit nicely into the cavity. There is a small gap (5mm) between DPF and cavity where insulation material will be placed to avoid any thermal loss by the DPF into the wall of the cavity.

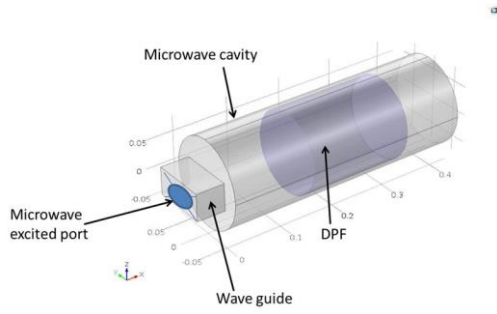

Figure 5: COMSOL geometry of the proposed microwave cavity

The material of the DPF is SiC and selected from the COMSOL library and the waveguide and cavity was chosen as basic steel. The cavity and waveguide is set as filled with air. The chosen material properties of Air and SiC are shown in Fig. 6.

Property	Name	Value	Unit
Relative permeability	mur	1	1
Relative permittivity	epsilononr	1	1
Electrical conductivity	sigma	0[S/m]	S/m
Heat capacity at constant pressure	Cp	Cp([T]/[K])/J/(kg*K)	J/(kg-K)
Density	rho	rho(pA[1/Pa],T[1/K])[kg/m^3]	kg/m^3
Thermal conductivity	k	k(T[1/K])[W/(m*K)]	W/(m-K)

(a)

Property	Name	Value	Unit
Relative permittivity	epsilononr	30-11*j	1
Relative permeability	mur	1	1
Electrical conductivity	sigma	0.001	S/m
Thermal conductivity	k	120	W/(m-K)
Density	rho	3000	kg/m^3
Heat capacity at constant pressure	Cp	750	J/(kg-K)

(b)

Figure 6: Material Properties used in MAGS COMSOL Model (a) Air and (b) SiC

The model was simulated with two physics, 'Electromagnetic Wave' and 'Heat Transfer in Solids', and coupled together. Electric field calculations was simulated same way as defined in the equations (1) and (2). The governing equations of the heat transfer are given below;

$$\rho C_p \cdot \nabla T = \nabla \cdot (k \nabla T) + Q \quad (4)$$

where, ρ is the density of the material, C_p is specific heat capacitance at constant pressure (1 atm) and Q is the heat source. The heat in this is electromagnetic heating and given by,

$$\begin{aligned} Q &= Q_{rh} + Q_{ml} \\ Q_{rh} &= \frac{1}{2} \text{Re}(\mathbf{J} \cdot \mathbf{E}^*) \\ Q_{ml} &= \frac{1}{2} \text{Re}(\mathbf{B} \cdot \mathbf{H}^*) \end{aligned} \quad (5)$$

where, Q_{rh} is heating by electric field and Q_{ml} is due to the magnetic field heating. \mathbf{J} , \mathbf{B} and \mathbf{H} are current density, magnetic field strength and magnetic flux respectively.

4. Simulation Results and Discussion

A series of simulations were performed in order to understand the followings in a systematic manner. All the simulations presented in this section were performed with the microwave frequency of 2.45GHz and power of 1000W.

- (1) Dimensions of the Waveguide: This allows to choose the right waveguide dimensions.
- (2) Dimensions of the cavity: This allows to choose the right location within the microwave cavity for the placement of DPF
- (3) Thermal profile of the DPF: This allows us to understand the temperature profile of the DPF and hence to ensure enough heating is achieved across the DPF.

A selected set of results are presented in Fig. 7, Fig. 8 and Fig. 8. Two waveguide dimensions are used in the simulations to investigate if it makes any significant difference; WG1 - 78mm by 18mm and WG2 - 96mm by 48mm. In the first set of simulations, the DPF was placed 10mm from the front face of the cavity. Fig. 7(a) Fig. 7(b) shows the electric field distribution across the front face of the DPF for both of the waveguides. Though there is any noticeable difference was observed from these two figures, WG2 has shown marginally better results, the increased average electric field within the DPF. Thus, average electric field for WG1 is 825V/m and 777V/m for WG2. Fig. 7(c) shows the electric field within the DPF along the x direction through the middle of the DPF. As can be noticed, the Efield exponentially decay for two reasons; the standing Efield strength would fade out from the peak along the x direction and dielectric property of DPF would make the Efield decrease exponentially.

Fig. 8 shows the temperature profile of the DPF with WG2. The simulation was performed for the time period of 10mins and initial temperature of the whole set-up was set to 20°C. As can be seen in Fig.8(a), the front face of the DPF become close to 500°C within 10 minutes of heating and center of face exhibits the highest temperature. Fig. 8(b) show the temperature

through DPF along X direction when and $Z=0$ and the temperature decreases exponentially in similar fashion as the Efield. However, the temperature difference between maximum and minimum is only 15°C which is only less than 20% of the maximum.

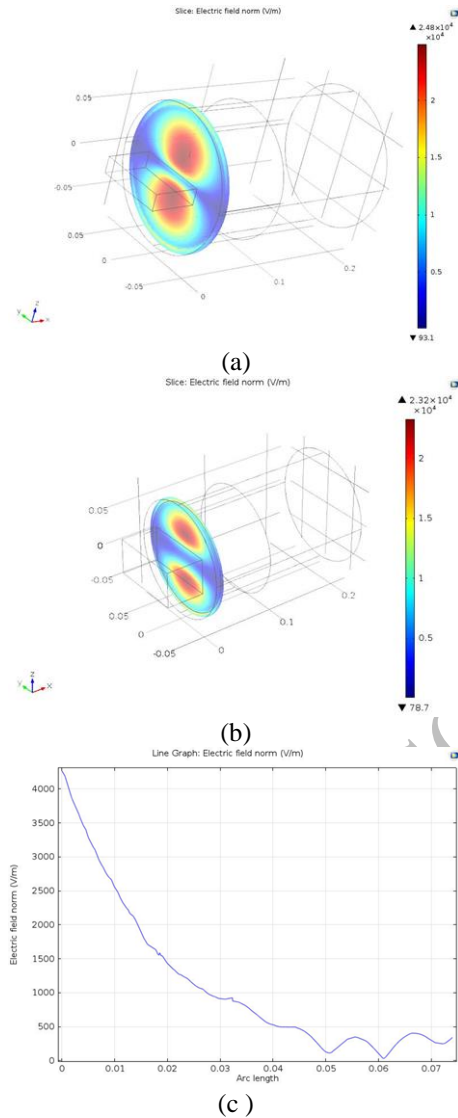

Figure 7: Electric field distribution with DPF
 (a) across the front face of the DPF for WG1
 (b) across the front face of the DPF for WG2
 (c) through the middle of the DPF for WG2

Another set of simulations were performed to find a right of dimensions for Efield strength area is somewhere near the middle of the cavity for a balanced position, in terms of gravity, of DPF. The length of the cavity was varied and the waveguide dimensions were set to 96mm x

48mm, as this was the dimensions of the waveguide available in the lab for further experiments. During these simulations DPF was not included for faster simulations. The simulation results are shown in Fig. 8. As can be seen, the standing wave pattern of Efield varies as the length of the cylindrical cavity varies. When the length of the cavity is 533mm, there is a high Efield strength in the middle of the cavity (i.e.: half way along the x direction) and therefore shows ideal cavity length to place the DPF for regeneration.

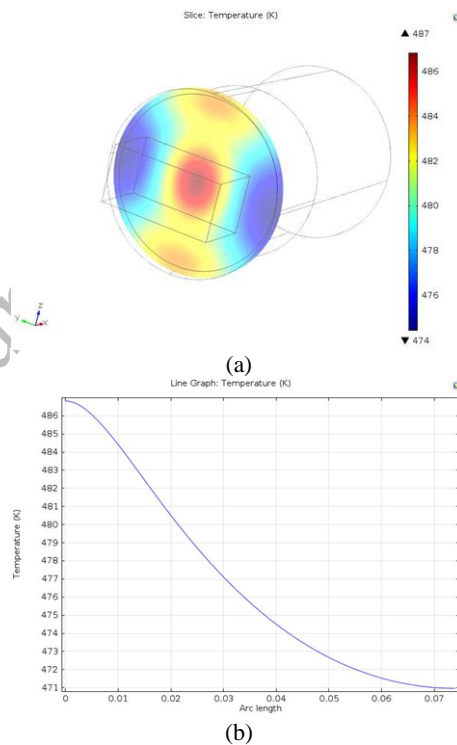

Fig. 8: Temperature profile of the DPF with WG2
 (a) across the front face of the DPF
 (b) through the middle of the DPF

5. Conclusion

COMSOL Multiphysics software was used to model and simulate the heating of DPF by electromagnetic source at the microwave frequency of 2.45GHz. Experimental results of DPF regeneration was presented and compared with the results from simulation of the microwave cavity. A series of COMSOL simulations were performed to find the right dimensions of the microwave cavity for a given

dimensions of the DPF. COMSOL has been very useful software for calculating electric field distribution and thermal distribution within the microwave cavity and DPF.

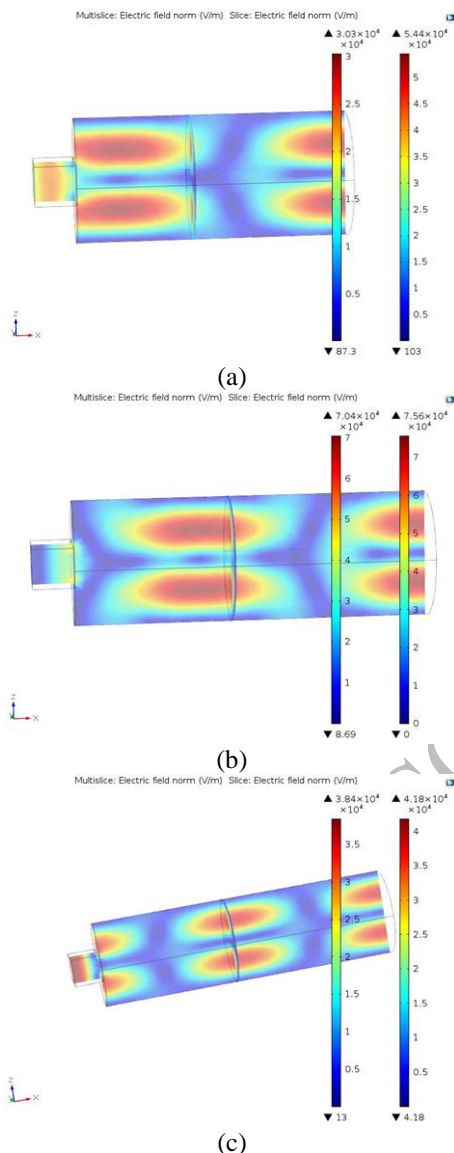

Fig. 8 Efield for various dimensions of the cavity
(a) 333mm (b) 433mm and (c) 533mm

6. References

(1) John P.A. Neeft, Michiel Makkee, Jacob A. Moulijn, "Diesel particulate emission control", *Fuel Processing Technology*, 47, 1-69 (1996).

- (2) Claus Görsmann, 'Catalytic Coatings for Active and Passive Diesel Particulate Filter Regeneration', *Monatshefte für Chemie / Chemical Monthly*, **136**, 91-105 (2005).
- (3) Vincenzo Palmaa, Paolo Ciambelli, Eugenio Meloni, Agusti Sin, "Study of the catalyst load for a microwave susceptible catalytic DPF", *Catalysis Today*, **216**, 185-193, (2013).
- (4) Hongmei An, Caitlin Kilroy, Paul J. McGinn, "An examination of microwave heating to enhance diesel soot combustion", *Thermochimica Acta.*, 435, 57-63, (2005).
- (5) Manivannan, N., Balachandran, W., Belega, R. and Abbod, M., 'Microwave Plasma System Design and Modelling for Marine Diesel Exhaust Gas Abatement of NO_x and SO_x', *International Journal of Environmental Science and Development*, **6**, 151-154, (2015).

7. Acknowledgements

Authors wish to acknowledge InnovateUK for the financial support provided to the project 'Marine Exhaust Gas Treatment System (MAGS) {grant reference number 42471-295209}', in which, the presented work is part of.