

**Bryn Mawr College**  
**Scholarship, Research, and Creative Work at Bryn Mawr**  
**College**

---

Physics Faculty Research and Scholarship

Physics

---

1977

# The electron-methyl group spin-spin interaction

Peter A. Beckmann

*Bryn Mawr College*, [pbeckman@brynmawr.edu](mailto:pbeckman@brynmawr.edu)

[Let us know how access to this document benefits you.](#)

Follow this and additional works at: [https://repository.brynmawr.edu/physics\\_pubs](https://repository.brynmawr.edu/physics_pubs)

 Part of the [Physics Commons](#)

---

## Custom Citation

Beckmann, Peter A. 1977. "The electron-methyl group spin-spin interaction." *Molecular Physics* 34.3: 665-680.

This paper is posted at Scholarship, Research, and Creative Work at Bryn Mawr College. [https://repository.brynmawr.edu/physics\\_pubs/118](https://repository.brynmawr.edu/physics_pubs/118)

For more information, please contact [repository@brynmawr.edu](mailto:repository@brynmawr.edu).

## The electron-methyl group spin-spin interaction

Peter Beckmann

*Molecular Physics* 34.3: 665-680.

<https://doi.org/10.1080/00268977700102031>

Abstract: The nuclear spin symmetry conversion transition, whereby a methyl group changes tunnelling state ( $A \leftrightarrow E$ ) and total nuclear spin ( $\Delta I = \pm 1$ ), is made resonant by the flip of an unpaired electron spin ( $\Delta m_s = \pm 1$ ). The coupling between an unpaired electron in a free radical and a methyl group in a nearby molecule is via the inter-molecular spin-spin interaction. The matrix elements and transition probabilities for this transition are calculated explicitly. The motivation behind the calculation is to aid in the interpretation of electron spin relaxation experiments in  $\gamma$ -irradiated 4-methyl-2,6-*t*-butylphenol where these resonant transitions have a profound effect. The results presented have also been useful in the interpretation of nuclear magnetic resonance experiments in the same substance.

### 1. Introduction

Nuclear spin symmetry requires that a change of methyl group tunneling state be accompanied by nuclear spin conversion. If unpaired electron spins in the form of free radicals are present, this spin conversion tunnelling transition can be made resonant by the simultaneous flip of an electron spin. This resonant condition is satisfied at an applied magnetic field where the field dependent electron Larmor frequency is the same as the field-independent tunnelling frequency.

Free radicals can be produced by  $\gamma$ -irradiation and in  $\gamma$ -irradiated 4-methyl-2,5-di-*t*-butylphenol ( $\gamma$ -MDBP), the methyl group tunnelling frequency is 9.45 GHz [1]. This is a convenient frequency, since it is accessible with a conventional X-band electron spin resonance (E.S.R.) spectrometer. Methyl group spin conversion has been observed directly by a clever temperature and magnetic field switching experiment [2] and by its effect on electron spin relaxation [3]. A detailed study of the frequency dependence of the relaxation process [4] may give considerable insight into the distribution of tunneling frequencies. Phenomena related to the E.S.R. studies can also be observed with nuclear magnetic resonance (N.M.R.). The shape and other interesting properties of the tunnelling resonance can be investigated by a frequency study of the nuclear spin relaxation [5-7] and the conversion process manifests itself in a temperature study of the nuclear spin relaxation rate [8]. Also, spin symmetry conversion of tunnelling methyl groups can be detected thermally [9, 10].

In this paper we shall concentrate on the theoretical aspect of the resonant conversion process involving a methyl group and an electron. Although the main incentive of such an investigation is the need to calculate certain transition probabilities relevant to the E.S.R. experiments in  $\gamma$ -MDBP [4], some of the results have been applied to an analysis of N.M.R. experiments in  $\gamma$ -MDBP [6]. Finally, many of the results are quite general and it is hoped that they will be helpful in the interpretation of other experiments in molecular solids containing tunnelling methyl groups.

The peculiar nature of the electron spin relaxation in  $\gamma$ -MDBP can be understood qualitatively by considering the following model.  $\gamma$ -irradiation of a single crystal of MDBP produces a very low concentration of free radicals containing a single unpaired electron and it

can be assumed that a methyl group on a nearby undamaged molecule will interact with only one electron. At low temperatures, only the 4-methyl group need be considered, since the di-*t*-butyl groups are completely hindered. Also, the 4-methyl group on the damaged molecule can be neglected, since it has a tunnelling frequency of 4-13 GHz [1]. The coupling between the 4-methyl groups on undamaged molecules and an electron on a damaged molecule is due to the intermolecular spin-spin interaction between the electron and the three protons. When the resonant condition is satisfied, a change of methyl group tunnelling state accompanied by an electron flip will tend, independent of the lattice, to bring the electron and a methyl group to a common temperature. At the same time, however, the electron is coupled to the lattice which tends to bring the electron to an equilibrium temperature given by that of the lattice. This electron-lattice coupling is introduced phenomenologically through the relaxation rate  $R_s$ . The coupling between the methyl groups and the lattice is extremely weak at 4 K, as has been demonstrated experimentally [3], and can be completely ignored. Therefore, the only communication link between the methyl group and the lattice is via the electron. With this model, Clough and Hill [3] constructed the following coupled equations describing the relaxation process of a system composed of an electron in a sea of methyl groups;

$$\text{and } \left. \begin{aligned} \frac{d}{dt} \beta_s &= -R_s \beta_s - \sum_i W_{is} (\beta_s - \beta_i) \\ \frac{d}{dt} \beta_i &= -W_{is} (\beta_i - \beta_s) \end{aligned} \right\} \quad (1)$$

$\beta_s$  and  $\beta_i$  refer to the departure from equilibrium of the inverse temperature for the electron and the *i*th methyl group. The electron relaxation rate is  $R_a$  and  $W_{is}$  is the transition probability per unit time for the resonant transition discussed previously and indicated in figure 1. The initial conditions for (1) depend on the experimental preparation but if the E.S.R. signal is saturated for a time  $t_a$ , it can easily be shown that  $\beta_s(0) = -\beta_i$  and  $\beta_i(0) = \beta_i(\exp(-W_{is}t_a) - 1)$  where  $\beta_i$  is the inverse lattice temperature.

In order to solve the coupled equations (1), the  $W_{is}$  are required. As discussed in greater detail in § 2, these transition probabilities depend on the distance between the methyl group and the electron, the orientation of the methyl group with respect to the position of the electron and the orientation of the methyl group with respect to the applied magnetic field. In MDBP, all these parameters can be determined, since the crystal structure is well known [11]. The only unknown parameter in  $W_{is}$  is the tunnelling frequency of each methyl group. Even though the average tunnelling frequency is known to be 9.45 GHz, it is also known that the presence of the free radical leads to a distribution of tunnelling frequencies [5, 7], probably because the defect creates strain in the crystal which perturbs the intermolecular potential and therefore the barrier to hindered rotation. Of interest at this time are the details of this distribution and in particular the dependence of the tunnelling splitting on the distance from the electron. For a given model of the tunnelling distribution the  $W_{is}$  can be solved explicitly with no adjustable parameters. The coupled equations (1) can then be solved and compared with the experimental results [4].

The two-fold splitting of the ground torsional oscillator state of a methyl group [12] is shown in figure 1. The ground, or *A* state, has associated with it a total nuclear spin of  $I = \frac{3}{2}$  and the doubly-degenerate excited, or *E* state, has associated with it  $I = \frac{1}{2}$ . These conditions are imposed by nuclear spin symmetry in complete analogy with ortho and para-hydrogen. Thus a transition between tunnelling states corresponds to spin conversion since  $\Delta I = \pm 1$ . Such a

transition will be accompanied by a change of  $\Delta m$  (no subscript on  $m$  implies  $m_1$ ) of 0 or  $\pm 1$  since the electron-methyl group spin-spin interaction hamiltonian is linear in the nuclear (and electron) spin operator. Similarly, for the electron,  $\Delta m_8 = 0, \pm 1$ , but since we are interested in the resonant process only, we restrict ourselves to  $\Delta m_8 = \pm 1$ . The total transition probability  $W$  (suppressing the subscripts) appearing in the coupled equations (1) relevant to the E. S. R. experiments and also appearing in expressions relevant to the N.M.R. experiments [5] can be thought of as the sum of three terms, corresponding to  $|\Delta M| = 0, 1$  or  $2$  where  $\Delta M = \Delta m_8 + \Delta m$  with  $\Delta m_8 = \pm 1$  and  $\Delta m_8 = 0, \pm 1$ . Such a separation is particularly relevant to the N.M. R. experiments. Each of these three types of transitions will, in turn, be the sum of several transition probabilities since a given  $\Delta m$  can occur in several ways as indicated in figure 1.

The transition probabilities  $W$  for the resonant process are calculated in the following section. Those persons not concerned with the mathematical details can go directly to § 3 without loss of continuity, since it is intended to be self-contained.

## 2. CALCULATION OF RESONANT TRANSITION PROBABILITIES

### 2.1. Introduction

We consider the composite system of a methyl group and an electron. The former is assumed to be in its ground torsional state [12]. The hamiltonian for this system can be taken to be

$$\mathcal{H} = \mathcal{H}_t + \mathcal{H}_n + \mathcal{H}_s + \mathcal{H}_d. \quad (2)$$

The first term is the tunnelling hamiltonian which gives rise to the two-fold splitting  $h\nu_1$  of the ground torsional state. The ground state is labelled by  $T = A$  and the doubly-degenerate excited states by  $T = Ea$  and  $Eb$ . The second term in (2) is the nuclear Zeeman hamiltonian for the three protons in the methyl group and the nuclear Zeeman states are characterized by the quantum numbers  $I$  and  $m$ . Spin symmetry statistics require that  $T = A \leftrightarrow I = \frac{3}{2}$  and  $T = Ea, Eb \leftrightarrow I = \frac{1}{2}$ . The projections  $m$  are  $\pm \frac{1}{2}$  for  $I = \frac{1}{2}$  and  $\pm \frac{3}{2}, \pm \frac{1}{2}$  for  $I = \frac{3}{2}$ . The third term in (2) is the electron Zeeman hamiltonian and the electron Zeeman states are characterized by the projections  $m_8 = \pm \frac{3}{2}$ . The last term in (2) is the dipolar interaction hamiltonian which couples the states of the system which are characterized by the set  $(TImms)$ .

A resonant transition implies  $I = \frac{3}{2} \leftrightarrow \frac{1}{2}$  accompanied by  $m_8 = \frac{1}{2} \leftrightarrow \frac{1}{2}$ . In general, however, the total transition probability for a change of state  $(I'm_8')$   $(Im)$  is given by

$$W = \sum_{T'} \sum_{m'} P_{T'm'} \sum_T \sum_m W(T'I'm'_m'; TImms), \quad (3)$$

where  $P_{Tm}$  is the probability of being in the state  $(Tm)$  given the system is in the state  $(Im_8)$ . In determining  $P_{Tm}$ , we can neglect the nuclear Zeeman energies since the nuclear Larmor frequency  $\nu_n$ , is much smaller than either the tunneling frequency  $\nu_1$  or the electron Larmor frequency  $\nu_8$ . Thus  $P_{Tm}^{-1}$  is the degeneracy associated with the  $(Im_8)$  state and is equal to 4 since there is one  $T$  state and four  $m$  states for  $I = \frac{3}{2}$  and two  $T$  states and two  $m$  states for  $I = \frac{1}{2}$ . The transition probabilities between individual states of the system are given by [13], pages 27-28,

$$W(T' I' m' m_s'; T I m m_s) = \hbar^{-2} |\{\Psi(T' I' m' m_s')\}^* \mathcal{H}_d \times \{\Psi(T I m m_s)\}|^2 g\{(m_s' - m_s)\nu_s + (l' - l)\nu_t - (m' - m)\nu_n\}, \quad (4)$$

where we can associate  $l=2$  with  $T = Ea, Eb$  and  $l = 1$  with  $T = A$ .

The wavefunctions  $\Psi(T I m m_s)$  are discussed in the next section and  $\mathcal{H}_d$  is discussed in § 2.3. The matrix element and transition probabilities are calculated in § 2.4. The normalized distribution function  $g(\nu)$  appearing in (4) is discussed in § 3.

## 2.2 The wavefunctions

We require wavefunctions diagonal in the first three terms of (2). The dipolar hamiltonian is then assumed to be small in the usual quantum-mechanical sense that its effect can be treated by first-order perturbation theory via its matrix elements in (4). The total wavefunctions  $\Psi(T I m m_s)$  in (4) will contain spatial as well as spin parts, so we now write them  $\Psi(T I m m_s r r_s)$ , where  $r$  refers to the methyl group and  $r_s$  to the electron. The methyl group state has associated with it a spin (plus tunnelling) function  $\chi(T I m)$  and a spatial function  $K(r)$ . The electron state has associated with it a spin function  $\phi(m_s)$  and a spatial function  $L(r_s)$ . It is convenient to construct these functions according to their transformation properties under the operations of the point group  $C_3$ , the group relevant to a triangle of spins where only even permutations or real rotations about an axis perpendicular to the group are permitted [12]. The label  $\Gamma$  refers to the three possible one-dimensional irreducible representations of  $C_3$  [14];  $A, Ea$  and  $Eb$ . Since  $C_3$  contains only one-dimensional representations, the total wavefunction is given by a single product of the four constituent wavefunctions and we can write

$$\Psi(T I m m_s r r_s) = K^{\Gamma^*}(\mathbf{r}) \chi^{\Gamma}(T I m) L(\mathbf{r}_s) \Phi(m_s), \quad (5)$$

where no superscript means the function must transform according to the totally symmetric  $A$  representation. This is clearly the case for  $L$  and  $\Phi$ , since the electron is to be treated as a point source. If  $\chi^{\Gamma}$  transforms like the  $\Gamma$  representation, then  $K^{\Gamma^*}$  must transform like the  $\Gamma^*$  representation, since the representation product  $\Gamma^* \otimes \Gamma = A$  (where  $Ea^* = Eb$ ). Thus  $\Psi$  will transform like  $A$ .

The electron spin functions are trivial. For the electron spatial functions, we assume a Kronecker delta function, namely  $L(\mathbf{r}_s) = \delta(\mathbf{r}_s - \mathbf{R}_s)$ , where the eigenvalue of any spatial operator  $f(\mathbf{r}_s)$  is simply  $f(\mathbf{R}_s)$ . The methyl group spin functions  $\chi^{\Gamma}(T I m)$  can be written  $\chi^{\Gamma}(I m)$ , since there is a one-to-one correspondence between the tunnelling states  $T$  and the irreducible representation  $\Gamma$  for these functions. The functions  $\chi^{\Gamma}(I m)$  are known [12] and can be expressed in the convenient form

$$\text{and } \left. \begin{aligned} \chi^A(\frac{3}{2}, \frac{3}{2}) &= |+++ \rangle, \\ \chi^{\Gamma}(I, \frac{1}{2}) &= \frac{1}{\sqrt{3}} \{ \Lambda_1^{\Gamma} |++- \rangle + \Lambda_2^{\Gamma} |+-+ \rangle + \Lambda_3^{\Gamma} |-++ \rangle \}, \end{aligned} \right\} \quad (6)$$

where  $\Delta_p^{\Gamma}$  are the elements of the character table for  $C_3$  [14] as given in the table. The spin functions for  $m = -\frac{3}{2}$  and  $-\frac{1}{2}$  are obtained by interchanging  $+$  and  $-$  which refer to the  $\pm \frac{1}{2}$  and  $-\frac{1}{2}$  spin states of the individual protons in the methyl group. In constructing the methyl-group spatial functions, it is assumed [15] that the classical rotation of the methyl group is strongly hindered. This means that the proton *coordinates* are localized at the corners of an equilateral

triangle fixed in space. At the same time, however, this rigid rotor can undergo rapid quantum-mechanical tunnelling between the three equivalent positions of the fixed triangle. With this assumption, the properly symmetrized methyl-group spatial functions can be taken to be

$$K^\Gamma(\mathbf{r}) = \frac{1}{\sqrt{3}} [\Lambda_1^\Gamma \{ \delta(\mathbf{r}_1 - \mathbf{R}_1) \delta(\mathbf{r}_2 - \mathbf{R}_2) \delta(\mathbf{r}_3 - \mathbf{R}_3) \} \\ + \Lambda_2^\Gamma \{ \delta(\mathbf{r}_1 - \mathbf{R}_2) \delta(\mathbf{r}_2 - \mathbf{R}_3) \delta(\mathbf{r}_3 - \mathbf{R}_1) \} \\ + \Lambda_3^\Gamma \{ \delta(\mathbf{r}_1 - \mathbf{R}_3) \delta(\mathbf{r}_2 - \mathbf{R}_1) \delta(\mathbf{r}_3 - \mathbf{R}_2) \}], \quad (7)$$

where the subscripts on  $r$  refer to the *protons* and the subscripts on  $\mathbf{R}$  refer to the *coordinates* of the fixed triangle.

The characters  $\Lambda_p^\Gamma$  for the point group  $C_3$ .

		$A$	$\Gamma$ $Ea$	$Eb$
	1	1	1	1
$p$	2	1	$\epsilon$	$\epsilon^*$
	3	1	$\epsilon^*$	$\epsilon$

$$\epsilon = \exp(i2\pi/3).$$

As an aside, we note that even though the two tunnelling states  $T = Ea$  and  $Eb$  are degenerate, they are distinguishable, as shown by rotational polarization experiments [16]. Thus we do not treat the two degenerate irreducible representations  $\Gamma = Ea, Eb$  by which the methyl-group spin functions for  $T = Ea$  and  $Eb$  transform as the two components of a two-dimensional representation.

We now discuss two reference frames relevant to the problem. The nuclear spin eigenvalues  $m$  and the electron spin eigenvalues  $m_s$  refer to a space-fixed frame (SFF) whose  $z$ -axis is coincident with the applied magnetic field  $\mathbf{F}$ . The molecular or methyl-group fixed frame (MFF) has its origin at the centre of the triangle of spins and its  $z$ -axis perpendicular to the group. The first proton *coordinate* makes an angle  $\lambda$  with the  $x$ -axis of MFF. In this frame the vectors  $\mathbf{R}_p$  in (7) specifying the proton co-ordinates are  $\mathbf{R}_p = (R_p, \theta_p, \varphi_p) = (\Delta, \pi/2, \varphi_p)$ , where  $\varphi_1 = \lambda$ ,  $\varphi_2 = \lambda + 2\pi/3$  and  $\varphi_3 = \lambda - 2\pi/3$ . The parameter  $\Delta$  is the distance from the centre of the triangle to each proton. The electron coordinates in MFF will be denoted  $\mathbf{R}_s = (R_s, \theta_s, \varphi_s)$ . The orientation of SFF as expressed in MFF is specified by the angles  $(\theta_1, \varphi_1)$ . In order to transform from SFF to MFF we must rotate through the Euler angles (as defined by Rose [17])  $\alpha\beta\gamma = 0, -\theta_j, -\varphi_j$ . That the first angle is zero follows from the fact that we need not specify uniquely the  $xy$  plane of SFF. The vectors and angles discussed in this section are shown in figure 2.

### 2.3 The dipolar Hamiltonian

The dipolar interaction between a methyl group and an electron has been discussed previously [5]. The advancement here is, that by expressing the hamiltonian in spherical tensor form, the relevant angles appear in a natural way and, more important, the matrix elements are easily calculated via the Wigner-Eckart theorem. Throughout the rest of § 2 we shall refer frequently to Rose [17]. Equations referred to as (Rn) imply equation (n) in Rose. Also, all

spatial and spin operators will appear with a tilde underneath. Those referring to SFF will have a hat over them and those referring to MFF will not.

The dipolar interaction between two magnetic moments is given in the conventional form by Abragam ([13], pages 97 and 103-104). This, in turn, can be transformed into spherical tensor form [18, 19]. If one then sums over the three protons ( $p = 1, 2, 3$ ) the hamiltonian for the dipole-dipole interaction between an electron and a methyl group takes on the form

$$\mathcal{H}_d = \left(\frac{24\pi}{5}\right)^{1/2} \gamma_e \gamma_n \hbar^2 \sum_{p=1}^3 \underline{\mathbf{r}}_{ps}^{-3} \sum_{\mu=-2}^{+2} (-1)^\mu Y_{2,-\mu}(\underline{\theta}_{ps}, \underline{\phi}_{ps}) T_{2,\mu}(\underline{\mathcal{S}}, \underline{\mathcal{I}}^p). \quad (8)$$

$Y_{2,\mu}$  is a spherical harmonic of the angles (operators)  $\theta_{ps}, \phi_{ps}$  that specify the vector (operator)  $\mathbf{r}_{ps}$  between the  $p$ th proton and the electron. The gyromagnetic ratios of an electron and a proton are  $\gamma_e$  and  $\gamma_n$  respectively and both are defined as positive quantities.  $T_{2,\mu}(\underline{\mathcal{S}}, \underline{\mathcal{I}}^p)$  is the  $\mu$ . component of an irreducible spherical tensor of rank 2 as defined by (R5.2) and given in (10) below in terms of the spin operators. Equation (8) is specified in MFF. However, the angular momentum eigenvalues  $m$  and  $m_8$  in the spin functions are those of the SFF spin operators. Therefore, we express  $T_{2,\mu}(\underline{\mathcal{S}}, \underline{\mathcal{I}}^p)$ , where  $\underline{\mathcal{S}}$  and  $\underline{\mathcal{I}}^p$  refer to MFF in terms of  $T_{2,\mu}(\underline{\mathcal{S}}, \underline{\mathcal{I}}^p)$ , where  $\underline{\mathcal{S}}$  and  $\underline{\mathcal{I}}^p$  refer to SFF. This transformation is given by (R5.1)

$$T_{2,\mu}(\underline{\mathcal{S}}, \underline{\mathcal{I}}^p) = \sum_{\nu} D_{\nu\mu}^{(2)}(0, -\theta_f, -\phi_f) T_{2,\nu}(\underline{\mathcal{S}}, \underline{\mathcal{I}}^p), \quad (9)$$

where  $D_{\nu\mu}^{(2)}$  is a rotation matrix of order 2 as defined by Rose and is a function of the Euler angles specifying the magnetic field as discussed in the previous section. Finally, the second-rank spin tensor is given by

$$T_{2,\nu}(\underline{\mathcal{S}}, \underline{\mathcal{I}}^p) = \sum_{\eta} C(1, 1, 2; \eta, \nu - \eta) \underline{\mathcal{S}}_{\eta} \underline{\mathcal{I}}_{\nu - \eta}^p, \quad (10)$$

where  $C(L_1, L_2, L; M_1, M - M_1)$  is a Clebsch-Gordan coefficient and  $\underline{\mathcal{I}}_{\nu} (\underline{\mathcal{I}} = \underline{\mathcal{S}} \text{ or } \underline{\mathcal{I}}^p)$  is the  $\tau$  component of a spherical vector operator  $I$  defined in (R5.9) in terms of the lowering and raising operators.

In order to cast (8) in a form which is irreducible with respect to  $C_3$ , we first express the spatial operators  $\underline{\mathbf{r}}_{ps} = (\underline{\mathbf{r}}_{ps}, \underline{\theta}_{ps}, \underline{\phi}_{ps})$  in terms of vectors more relevant to the symmetry of the problem; namely the position operator for the electron  $\underline{\mathbf{r}}_s = (\underline{\mathbf{r}}_s, \underline{\theta}_s, \underline{\phi}_s)$  and the position operator for the  $p$ th proton  $\underline{\mathbf{r}}_p = (\underline{\mathbf{r}}_p, \underline{\theta}_p, \underline{\phi}_p)$ . The three vectors are related by  $\underline{\mathbf{r}}_{ps} = \underline{\mathbf{r}}_s - \underline{\mathbf{r}}_p$  as can be seen from the corresponding coordinate vectors shown in figure 2. This transformation is straightforward but tedious and the details are discussed in the Appendix. The result is an infinite series in powers of  $\underline{\mathbf{r}}_p / \underline{\mathbf{r}}_s$  (times  $\underline{\mathbf{r}}_s^{-3}$ ) and since the eigenvalue of this ratio is  $\Delta / R_s$  (see previous section), and since  $\Delta \ll R_s$ , we carry the calculation to order  $\underline{\mathbf{r}}_p / \underline{\mathbf{r}}_s$ . The result from the Appendix is that the factor  $\underline{\mathbf{r}}_{ps}^{-3} Y_{2,-\mu}(\underline{\theta}_{ps}, \underline{\phi}_{ps})$  in (8) is given by

$$\begin{aligned} \underline{\mathbf{r}}_{ps}^{-3} Y_{2,-\mu}(\underline{\theta}_{ps}, \underline{\phi}_{ps}) &= \underline{\mathbf{r}}_s^{-3} Y_{2,-\mu}(\underline{\theta}_s, \underline{\phi}_s) - (20\pi)^{1/2} \underline{\mathbf{r}}_p \underline{\mathbf{r}}_s^{-4} \\ &\times \sum_{\xi=-1}^{+1} C(132; \xi, -\mu - \xi) Y_{1,\xi}(\underline{\theta}_p, \underline{\phi}_p) Y_{3,-\mu-\xi}(\underline{\theta}_s, \underline{\phi}_s). \end{aligned} \quad (11)$$

Substituting (11) (with (9) and 10)) into (8) gives rise to two terms corresponding to the two terms in (11).

The first term does not depend on the proton spatial operators  $\underline{\mathbf{r}}_p$  or, equivalently,



it does not depend on the structure of the methyl group. The only dependence on  $p$  is via the spin operator  $\hat{I}^p$ . The symmetrized nuclear spin operators are given by [5]

$$\hat{I}^\Gamma = \sum_p \Lambda_p^{\Gamma^*} \hat{I}^p, \quad (12)$$

and the sum on  $p$  of  $\hat{I}^p$  in this first term just gives  $\hat{I}^A$  since  $\Lambda_p A = 1$  for all  $p$  (table). Matrix elements of  $\hat{I}^A$  between the nuclear spin functions  $\chi^{\Gamma'}(Im')$  and  $\chi^\Gamma(Im)$  will only be non-zero when  $(\Gamma')^* \otimes A \otimes \Gamma = A$ , which implies  $I' = I$ . Thus this term in the hamiltonian cannot contribute to spin symmetry conversion and therefore will not contribute to any resonant phenomenon involving the methyl group and the electron.

For the second term arising from the substitution of (11) in (8) the dependence on  $p$  (using (9) and (10)) is given by  $r_p Y_{1,\xi}(\theta_p, \phi_p) \hat{I}_{v-\eta}^p$ . This is easily symmetrized with respect to  $C_3$  by defining  $\hat{M}_\xi^\Gamma$  through the relation

$$\sum_p r_p Y_{1,\xi}(\theta_p, \phi_p) \hat{I}_{v-\eta}^p = \sum_\Gamma \hat{M}_\xi^{\Gamma^*} \hat{I}_{v-\eta}^\Gamma. \quad (13)$$

Since  $\Gamma^* \otimes \Gamma = A$ , the total hamiltonian will transform like  $A$ . It is easily shown from (12) and (13) that the nuclear spin symmetry adapted spatial operators are given by

$$\hat{M}_\xi^\Gamma = \frac{1}{3} \sum_{p=1}^3 \Lambda_p^{\Gamma^*} r_p Y_{1,\xi}(\theta_p, \phi_p). \quad (14)$$

Since  $r Y_{1,\xi}(\theta, \phi)$  is just the  $\tau$  spherical component of the vector  $\mathbf{r}$ , the  $\hat{M}_\xi^\Gamma$  can be thought of as the components of a vector  $\hat{M}^\Gamma \propto \sum_p \Lambda_p^{\Gamma^*} r_p$  which is precisely the transformation used by Clough and Hobson [5]. When (13) is substituted into the hamiltonian, we can omit the  $\Gamma = A$  part for the same reasons given in the previous section. In any event, it can be shown that all the spatial matrix elements of  $\hat{M}^A$  are zero, even the ones allowed by the group theoretical multiplication rules.

Using (8), (9), (10), the second term in (11), and (13) with  $\Gamma = Ea, Eb$  (or equivalently,  $\Gamma = Ex$  with  $x = a, b$ ) we have the final symmetry-adapted form for the hamiltonian. We define the component indices  $\alpha, \beta, \rho$  and  $\sigma$  by  $\alpha = \eta, \beta = v - \eta, \sigma = \xi$  and  $\rho = -\mu - \xi$ , where  $\eta, v, \xi$  and  $\mu$  are those which appear in (8) to (11) and (13). The hamiltonian is

$$\mathcal{H} = \sum_{x=a,b} \sum_{\alpha\beta\rho\sigma} G_{\alpha\beta\rho\sigma} \hat{N}_\rho \hat{M}_\sigma^{Ex^*} \hat{S}_\alpha \hat{I}_\beta^{Ex}, \quad (15)$$

with  $G$  and  $\hat{N}$  given by

$$G_{\alpha\beta\rho\sigma} = (-1)^{\sigma+\rho} \left( \frac{24\pi}{5} \right)^{1/2} (20\pi)^{1/2} \gamma_e \gamma_n \hbar^2 C(1, 3, 2; \sigma, \rho) C(1, 1, 2; \alpha, \beta) \\ \times D_{\alpha+\beta, -\sigma-\rho}(0, -\theta_f, -\phi_f) \quad (16)$$

and

$$\hat{N}_\rho = r_s^{-4} Y_{3,\rho}(\theta_s, \phi_s). \quad (17)$$

Equation (15) contains two spatial operators  $\hat{N}$  and  $\hat{M}$  and two spin operators  $\hat{S}$  and  $\hat{I}$ , the former of each pair referring to the electron and the latter to the methyl group. The spatial operators are expressed in MFF and the spin operators in SFF. The correlation between the two frames is given by the dependence on the magnetic field angles  $\theta_j, \phi_j$  in  $G_{\alpha\beta\rho\sigma}$ .

## 2.4. Spin conversion matrix elements and transition probabilities



From (5) and (15), the matrix elements required in (4) are given by

$$(\psi')^* \mathcal{H}_d(\psi) = \sum_{x=a,b} \sum_{\alpha\beta\rho\sigma} G_{\alpha\beta\rho\sigma} [(L')^* \underline{N}_\rho(L)] [(K'^{\Gamma'})^* \underline{M}^{Ex^*} (K^{\Gamma^*})] \\ \times [(\Phi')^* \underline{S}_\alpha(\Phi)] [(\chi^{\Gamma'})^* \underline{I}_\beta^{Ex}(\chi^\Gamma)]. \quad (18)$$

The electron spatial matrix elements are trivial and from the discussion of the  $L$  functions in § 2.2 and the form of  $N$  in (17), we have

$$(L')^* \underline{N}_\rho(L) = R_s^{-4} Y_{3,\rho}(\theta_s, \phi_s). \quad (19)$$

This is equivalent to replacing the operator  $\underline{r}_s$  in  $\mathcal{H}_d$  by  $\mathbf{R}_s$ , the position coordinate of the electron in MFF.

For the methyl-group spin and spatial matrix elements, we must satisfy  $\Gamma'^* \otimes Ex \otimes \Gamma = A$  for  $x = a, b$ . Thus, for fixed  $\Gamma'$  and  $\Gamma$  in (18) only one term in the sum on  $x$  is non-zero. We can, without loss of generality, choose  $\Gamma' = A$  and  $\Gamma = Ex^*$ , since we are interested only in matrix elements which involve a change of tunnelling state. The methyl-group spatial matrix elements can be calculated from (7) and (14) and shown to be

$$(K^A)^* \underline{M}_\sigma^{Ex^*} (K^{Ex}) = \Delta \sum_p \Lambda_p^{Ex^*} Y_{1,\sigma}(\pi/2, \phi_p) \\ = \frac{1}{\sqrt{2}} \left( \frac{3}{4\pi} \right)^{1/2} \Delta \exp(-i\lambda) \quad (Ex = Eb; \sigma = -1) \\ = -\frac{1}{\sqrt{2}} \left( \frac{3}{4\pi} \right)^{1/2} \Delta \exp(i\lambda) \quad (Ex = Ea; \sigma = +1). \quad (20)$$

Thus for a given  $x$  (i.e.  $Ea$  or  $Eb$ ), only one term in the sum over  $\sigma$  in (18) is nonzero. As an aside, we note that the matrix element of  $M^A$  between all states  $\Gamma'$  and  $\Gamma$  is zero. The non-zero  $A$ -type matrix elements arise from the first term in (11) which has been discarded.

The electron and methyl-group spin matrix elements are calculated by employing the Wigner-Eckart theorem (R5.14) and are given by

$$\{\Phi(m_s')\}^* \underline{S}_\alpha \{\Phi(m_s)\} = C(\frac{1}{2}, 1, \frac{1}{2}; m_s, \alpha, m_s') \langle A, \frac{1}{2} \| A, 1 \| A, \frac{1}{2} \rangle \\ = \frac{\sqrt{3}}{2} C(\frac{1}{2}, 1, \frac{1}{2}; m_s, \alpha, m_s') \quad (21)$$

and

$$\{\psi^A(\frac{3}{2}, m')\}^* \underline{I}_\beta^{Ex} \{\psi^{Ex^*}(\frac{1}{2}, m)\} = C(\frac{1}{2}, 1, \frac{3}{2}; m, \beta, m') \langle A, \frac{3}{2} \| Ex, 1 \| Ex^*, \frac{1}{2} \rangle \\ = -\frac{\sqrt{6}}{2} \Lambda_2^{Ex} C(\frac{1}{2}, 1, \frac{3}{2}; m, \beta, m'). \quad (22)$$

The reduced matrix elements  $\langle \Gamma, J \| \Gamma', J' \| \Gamma'', J'' \rangle$  in (21) and (22) have been calculated by computing a single matrix element explicitly for each case. In order that the Clebsch-Gordan coefficients in (21) and (22) be non-zero, we must have  $m_s + \alpha = m_s'$  and  $m + \beta = m'$ . Thus for a given  $m, m', m_s$  and  $m_s'$  the sums on  $\alpha$  and  $\beta$  in (18) reduce to a single non-zero term.

The desired matrix elements are obtained by substituting (16), (19), (20), (21) and (22) into (18). Only the sum on  $p$  remains. There are two kinds of non-zero matrix elements:  $A \otimes Ea \otimes Eb$  and  $A \otimes Eb \otimes Ea$ . We emphasize that these two matrix elements are not equal and neither are their transition probabilities. This will be discussed later. It is convenient to define a function  $Z_{\Delta M}^{Ex}$  that contains all the angular dependence of the matrix element and further, has the useful property that a powder average of  $|Z_{\Delta M}^E|^2$  gives unity.  $Z_{\Delta M}^E$  is defined by

$$Z_{\Delta M}^{Ex}(\lambda, \theta_s, \phi_s, \theta_f, \phi_f) = \pm \Lambda_2^{Ex} \{ \exp(\pm i\lambda) \} (20\pi)^{1/2} \\ \times \sum_n C(2, 3, 1; -\rho \mp 1, \rho) D_{-\rho \mp 1, \Delta M}^{(2)*}(\phi_f, \theta_f, 0) Y_{3,\rho}(\theta_s, \phi_s), \quad (23)$$

where  $\Delta M = \Delta m + \Delta m_s = m' - m + m_s' - m_s$  and where the upper signs are chosen for  $Ex = Ea$  and the lower signs for  $Ex = Eb$ . In obtaining (23) we have used (R3.17 a) and (R4.12) to transform the Clebsch-Gordan coefficient and the rotation matrix. With this definition, the matrix elements are given by

$$(\psi')^* \mathcal{H}_d(\psi) = -\frac{3\sqrt{6}}{4} \gamma_e \gamma_n \hbar^2 \Delta R_s^{-4} q(M) Z_{\Delta M}^{Ex}, \quad (24)$$

where  $M$  is just shorthand notation for  $m_s', m_s, m', m$  and  $q(M)$  is just the product of three Clebsch-Gordan coefficients

$$q(M) = C(\frac{1}{2}, 1, \frac{1}{2}; m_s, m_s' - m_s) C(\frac{1}{2}, 1, \frac{3}{2}; m, m' - m) \\ \times C(1, 1, 2; m_s' - m_s, m' - m). \quad (25)$$

In (25), the first two terms arise out of the electron and methyl-group spin matrix elements respectively and the third term has its origin in the hamiltonian (equation (10)).

It is now convenient to investigate the properties of  $Z_{\Delta M}^{Ex}$  in (23). First, since the transition probabilities depend on  $|Z_{\Delta M}^{Ex}|^2$ , it is clear they do not depend on the angle  $\lambda$  specifying the orientation of the methyl group in the plane (figure 2). Secondly, using (R4.12) and (RIII.7) it can be shown that the dependence of  $|Z_{\Delta M}^{Ex}|^2$  on  $\phi_f$  and  $\phi_s$  is only through their difference  $\phi_{fs} = \phi_f - \phi_s$  as indicated in figure 2. This is to be expected and simply says that the choice of the  $xy$  axes in MFF does not matter. Using (R4.22), (R4.31) and (R3.16 a) it can be shown that

$$\{Z_{\Delta M}^{Ex}\}^* = (-1)^{\Delta M} Z_{-\Delta M}^{Ex*}, \quad (26)$$

or equivalently that

$$|Z_{\Delta M}^{Ex}|^2 = |Z_{-\Delta M}^{Ex*}|^2. \quad (27)$$

It is this property on which the rotational polarization experiments are based [16] and which leads to the distinguishability of the  $Ea$  and  $Eb$  states. It can be shown from (R4.60), (R4.61) and (R3.7) that a powder average of  $|Z_{\Delta M}^{Ex}|^2$  gives unity.

$$\langle |Z_{\Delta M}^{Ex}|^2 \rangle_{\theta_s, \phi_s, \theta_f, \phi_f} = 1. \quad (28)$$

Further, an average over the electron angles, but not the field angles, a situation which may be relevant for a single crystal, gives

$$\langle |Z_{\Delta M}^{Ex}|^2 \rangle_{\theta_s, \phi_s} = (-1)^{\Delta M} 15 \sum_{J=0}^2 [C(2, 2, J; \Delta M, -\Delta M) \\ \times C(1, 1, J; \mp 1, \pm 1) W(1, 2, 1, 2; 3, J)] P_J(\cos \theta_f), \quad (29)$$

where  $W(abcd;ef)$  is a Racah coefficient and  $P_J(\cos \theta_1)$  is a Legendre polynomial. Equation (29), which is evaluated explicitly in § 3, is obtained by using (R4.61), (R4.22), (R4.25), (R4.30), (R4.27 b), (R3.16 b), (R3.17 b), (R6.5 a) and (R3.16 c). It is easily verified that (28) and (29) are consistent.

The transition probabilities in (4) can now be given explicitly using (24) and (25). In order to make the general transition probability one which corresponds to a resonant transition, we can, without loss of generality, choose  $T = A$ ,  $I' = \frac{3}{2}$ ,  $m_s' = \frac{1}{2}$ ,  $I = 1$ ,  $T = Ex^*$ ,  $I = \frac{1}{2}$ ,  $m_s = -\frac{1}{2}$  and  $I$

= 2 in (4), since this is the case we have used in producing (24). Evaluating the first Clebsch-Gordan coefficient in (25), and substituting (24) and (25) into (4) gives the desired result

$$W(A, \frac{3}{2}, m', \frac{1}{2}; Ex^*, \frac{1}{2}, m, -\frac{1}{2}) = \frac{9}{4} \gamma_e^2 \gamma_n^2 \hbar^2 \Delta^2 R_s^{-8} \\ \times \{C(\frac{1}{2}, 1, \frac{3}{2}; m, m' - m)C(1, 1, 2; 1, m' - m)\}^2 \\ \times |Z_{1+m'-m}^{Ex}|^2 g\{\nu_s - \nu_l - (m' - m)\nu_n\}. \quad (30)$$

Substituting (30) into (3) with  $P_{Am'} = \frac{1}{4}$  gives the final result. In (3), the sum over  $T$  reduces to a single term  $T = A$  and the sum over  $T$  to two terms  $T = Ea$  and  $Eb$ . It is convenient to write the total transition probability as a sum over  $\Delta m$  (three terms for fixed  $\Delta m_s$  rather than a sum over  $m'$  and  $m$ ). When this is done, the total transition probability is given by (31) and (32) in the next section.

### 3. SUMMARY OF RESONANT TRANSITION PROBABILITY CALCULATION

The transition probability for the resonant spin conversion transition  $\Delta I = -1$  ( $A \rightarrow E$ ),  $\Delta I = +1$ ,  $\Delta m_s = 1$  (or  $\Delta I = +1$  ( $E \rightarrow A$ ),  $\Delta I = -1$ ,  $\Delta m_s = -1$ ) indicated in figure 1 is given by

$$W(A, \frac{3}{2}, m', \frac{1}{2}; Ex^*, \frac{1}{2}, m, -\frac{1}{2}) = \frac{9}{4} \gamma_e^2 \gamma_n^2 \hbar^2 \Delta^2 R_s^{-8} \\ \times \{C(\frac{1}{2}, 1, \frac{3}{2}; m, m' - m)C(1, 1, 2; 1, m' - m)\}^2 \\ \times |Z_{1+m'-m}^{Ex}|^2 g\{\nu_s - \nu_l - (m' - m)\nu_n\}. \quad (30)$$

The three individual contributions in (31) are given by

$$W = \sum_{\Delta m = -1}^{+1} |W_{|\Delta m + \Delta m_s|}|, \quad (\Delta m_s = +1 \text{ or } -1). \quad (31)$$

where  $\Delta M = \Delta m_s + \Delta m$ . In (32)  $\gamma_e$  and  $\gamma_n$  are the electron and proton gyromagnetic ratios of an electron and a proton,  $\Delta$  ( $= 1.02 \text{ \AA}$  in MDBP) is the distance from the centre of the triangle of protons in the methyl group to each proton and  $R_s$  is the distance between the methyl group and the electron. The parameter  $a_{|\Delta M|}$  is 6, 3 and 1 for  $|\Delta M| = 2, 1$  and 0. Clearly  $|\Delta M| = 2$  implies  $\Delta m = \Delta m_s$ ,  $|\Delta M| = 1$  implies  $\Delta m = 0$  and  $|\Delta M| = 0$  implies  $\Delta m = -\Delta m_s$ , since  $|\Delta m_s| = 1$ . We now discuss the remaining parameters in (32).

The normalized distribution function  $g(\nu)$  has been introduced phenomenologically as in the 'Golden Rule' approach to first-order perturbation theory ([13], pp. 27 and 28). Clearly, for a resonant process, involving a single methyl group and a single electron, we require  $\nu_s - \nu_l - \Delta m \nu_n = 0$ , where  $\nu_l$  is the tunnelling frequency and  $\nu_s$  and  $\nu_n$  are the electron and nuclear Larmor frequencies respectively. However, since there will, in general, be a spread in values of  $\nu_s$  and  $\nu_l$  there will be a spread in values of  $\nu_s$  (or  $\nu_o$ ) for which  $\nu_s - \nu_l = 0$ . (We are neglecting  $\nu_n$ , since  $\nu_n \ll \nu_s, \nu_l$ , but in some N.M.R. experiments the term  $\Delta m \nu_n$  in  $g(\nu)$  is important [5].) Thus  $g(\nu)$  is given by a convolution of the tunnelling frequency lineshape and the E.S.R. lineshape (and in some cases, the nuclear lineshape). In order to interpret the E.S.R. relaxation experiments, the following procedure is adopted to determine a specific form for  $g(\nu)$ . A model is assumed which gives the tunnelling frequency of each individual methyl group in a system composed of a single electron and its surrounding methyl groups. Now an ensemble of such systems is assumed where the set of tunneling frequencies in one system is the same as the set of tunnelling frequencies in any other system, but where the electron Larmor frequency  $\nu_s$  is allowed to vary from system to system. With this model the distribution function can be taken as the E.S.R. Gaussian lineshape function given by

$$g(\nu) = \frac{1}{(2\pi)^{1/2}\bar{\nu}} \exp \left\{ -\frac{\nu^2}{2\bar{\nu}^2} \right\}, \quad (33)$$

where  $\nu$  is the halfwidth of the E.S.R. spectrum which in the case of *y*-MDBP is 45 MHz. It must be remembered, however, that with this form for  $g(\nu)$ , explicit values of  $\nu_l$  must be associated with each individual methyl group.

The transition probability in (32) is proportional to  $R_s^{-8}$  so the strength of the interaction falls off rapidly with distance. This factor  $R_s^{-8}$  can be understood qualitatively by the following. The local dipolar field at the site of a methyl group due to an electron at a distance  $R_s$  is proportional to  $R_s^{-3}$ . However, a methyl group can only convert from one nuclear spin species to another if there is a gradient in this local field over a distance  $A$  characteristic of the size of the group. This gradient is proportional to  $(\Delta)R_s^{-4}$  and the transition probability is proportional to  $(\Delta)^2 R_s^{-8}$ .

The factors  $Z_{\Delta M}^{Ex}$  with  $x = a$  and  $b$  contain the angular dependence of the matrix elements. The fact that there are two terms takes into account the degeneracy of the  $I = \frac{1}{2}$  tunnelling state. The function  $Z_{\Delta M}^{Ex}$  has the property that the transition probability for  $A \rightarrow Ea$  transitions for a given  $\Delta M$  is the same as the transition probability for  $A \rightarrow Eb$  transitions for  $-\Delta M$ . This is stated formally in (27). Thus, replacing  $\Delta M$  by  $-\Delta M$  in (32) does not change the total transition probability as would be expected.

There are five angles that enter into  $Z_{\Delta M}^{Ex}$  and they are measured in a reference frame whose *z*-axis is perpendicular to the plane of the group. The angle  $\lambda$  specifies the orientation of the group in the plane, the angles  $\theta_s, \phi_s$  specify the vector  $\mathbf{R}_s$  and the angles  $\theta_l, \phi_l$  specify the orientation of the magnetic field. These angles are shown in figure 2. The matrix elements depend on the four angles  $\lambda - \phi_s$  (or  $\lambda - \phi_l$ ),  $\phi_s - \phi_l$ ,  $\theta_s$  and  $\theta_l$ , and since the first of these four enters only through a phase factor, the transition probability only involves the latter three. The explicit form for  $Z_{\Delta M}^{Ex}$  is given in (23). This is a useful expression, partially because it is straightforward to calculate on a computer, but more important, it is easily manipulated algebraically. This latter advantage manifests itself when it comes to computing averages as discussed below. Equation (23) can be interpreted in the following way. The matrix elements depend, via a third-order spherical harmonic, on the angles  $\theta_s, \phi_s$  specifying the electron-methyl group vector  $\mathbf{R}_s$ . However, the angular momentum projection quantum numbers  $m$  and  $m_s$  through which the transition is characterized refer to the magnetic field. Thus, this third-order spherical harmonic which concerns only the relative orientation of the methyl group and the electron must be rotated into the magnetic field axis. The rotation matrix is a function of the angles  $\theta_j, \phi_j$  specifying the relative orientation of the methyl group and the magnetic field. The particular rotation will depend on the values of  $\Delta M = \Delta M + \Delta M_s = m' - m + m_s' - m_s$ .

For experiments with a powder sample, the transition probability can be averaged over the angles  $\theta_s, \phi_s, \theta_j, \phi_j$ , and the factor in curly brackets in (32) becomes

$$\langle |Z_{\Delta M}^{Ea}|^2 + |Z_{\Delta M}^{Eb}|^2 \rangle_{\theta_s, \phi_s, \theta_j, \phi_j} = 2, \quad (34)$$

since the powder average of  $|Z_{\Delta M}^{Ex}|^2$  is unity as indicated in (28). For a single crystal, an average of the magnetic field angles  $\theta_j, \phi_j$  is, in general, not appropriate and, in fact, there will be as many unique sets of  $\theta_j, \phi_j$  as there are molecules per unit cell, since these angles are specified in the reference frame of the molecule. If one transforms the sum over all methyl groups in the coupled equations (1) to a sum over shells of methyl groups (i.e. those between  $R$  and  $R + \delta R$ ), then there will be many sets of angles  $\theta_s, \phi_s$  (one for each methyl group) in each shell. In

this case, an average over  $\theta_s, \phi_s$  may be appropriate, even for a single crystal. Such an average of  $|Z_{\Delta M}^{Ex}|^2$  (i.e. an average involving  $\theta_s, \phi_s$  but not  $\theta_j, \phi_j$ ) is given by (29) and (29) calculated explicitly yields

$$\langle |Z_{\Delta M}^{Ex}|^2 \rangle_{\theta_s, \phi_s} = 1 \mp \frac{1}{2}(\Delta M) \cos \theta_f + \frac{1}{4}\{(\Delta M)^2 - 2\}\{3 \cos^2 \theta_f - 1\}, \quad (35)$$

where the upper sign is taken for  $Ex = Ea$  and the lower sign for  $Ex = Eb$ . As expected, the field angle  $\phi_j$  does not enter. That (35) is consistent with the total angular average of  $|Z_{\Delta M}^{Ex}|^2$  being unity is clear. When (35) is used in (32), the middle term of (35) drops out and the factor inside the curly brackets in (32) can be replaced with

$$\langle |Z_{\Delta M}^{Ea}|^2 + |Z_{\Delta M}^{Eb}|^2 \rangle_{\theta_s, \phi_s} = 2 + \frac{2}{3}\{(\Delta M)^2 - 2\}\{3 \cos^2 \theta_f - 1\}. \quad (36)$$

Whether or not the average in (34) and (36) can be used will depend on the crystal structure of the material under study.

For an E.S.R. experiment, we can drop the term  $\Delta m \nu_n$  in the spectral density in (32). For a powder sample, therefore, the total transition probability per unit time for a spin conversion tunnelling transition is given by (using (31), (32) and (34))

$$W_i = \frac{5}{2} \gamma_e^2 \gamma_n^2 \hbar^2 \Delta^2 R_{s,i}^{-8} g(\nu_s - \nu_{t,i}), \quad (37)$$

where the subscript  $i$  labels the methyl group as in the coupled equations (1).

#### 4. CONCLUDING REMARKS

We have calculated the transition probability for the resonant process whereby a change of methyl-group tunnelling state is accompanied by the flip of an electron spin. The only approximation employed is that the distance between the electron and the methyl group (5.2 Å being the smallest such distance in  $\gamma$ -MDBP) be large compared with the size of the methyl group (1.02 Å for MDBP). The role such a process plays in electron spin relaxation has been discussed and the results have been presented in a form which is readily useable in aiding the interpretation of E.S.R. experiments. On reading the paper by Clough and Hobson [5], the application of the results obtained here to N.M.R. experiments will become apparent. In order to obtain numerical results for the transition probabilities one requires a knowledge of the crystal structure of the material under investigation. If a powder is used, only the electron-methyl group distances are required. If these parameters are known, the only remaining parameters involve the methyl group tunnelling frequencies as a function of distance from the electron. Thus, in a substance like  $\gamma$ -MDBP where all the geometric factors are known, the results presented here, in conjunction with E.S.R. relaxation experiments, should provide a test for models of the tunneling distribution [4]. In turn, successful models of the tunnelling frequency distribution can be used as a test for calculation of the intermolecular potential [7].

#### APPENDIX

Equation (Rn) refers to equation (n) in Rose [17]. We wish to express  $r_{ps}^{-3} Y_{2, -\mu}(\theta_{ps}, \phi_{ps})$  in equation (8) in terms of  $(r_s, \theta_s, \phi_s)$  and  $(r_p, \theta_p, \phi_p)$ . From the relation



$$\mathbf{r}_{ps} = \mathbf{r}_s - \mathbf{r}_p, \quad (\text{A } 1)$$

we have, by equating spherical components (R4.35)

$$\mathbf{r}_{ps} Y_{1,\xi}(\underline{\theta}_{ps}, \underline{\phi}_{ps}) = \mathbf{r}_s Y_{1,\xi}(\underline{\theta}_s, \underline{\phi}_s) - \mathbf{r}_p Y_{1,\xi}(\underline{\theta}_p, \underline{\phi}_p). \quad (\text{A } 2)$$

Expressing  $Y_2$  in terms of  $Y_1$  gives

$$Y_{2,-\mu}(\underline{\theta}_{ps}, \underline{\phi}_{ps}) = \left(\frac{10\pi}{3}\right)^{1/2} \sum_{\xi} C(1, 1, 2; \xi, -\mu - \xi) Y_{1,\xi}(\underline{\theta}_{ps}, \underline{\phi}_{ps}) \times Y_{1,-\mu-\xi}(\underline{\theta}_{ps}, \underline{\phi}_{ps}). \quad (\text{A } 3)$$

Equation (A 3) is multiplied by  $\mathbf{r}_{ps}^2$  and (A 2) substituted twice into the result. This will give a term involving only  $(\mathbf{r}_s, \underline{\theta}_s, \underline{\phi}_s)$ , another term involving only  $(\mathbf{r}_p, \underline{\theta}_p, \underline{\phi}_p)$  and a cross term involving all six parameters. For the first two terms, (A 3) can be used to retrieve  $Y_{2,-\mu}(\underline{\theta}_s, \underline{\phi}_s)$  and  $Y_{2,-\mu}(\underline{\theta}_p, \underline{\phi}_p)$ . Further, it can be shown that the two cross terms are equal. The result is

$$\mathbf{r}_{ps}^2 Y_{2,-\mu}(\underline{\theta}_{ps}, \underline{\phi}_{ps}) = \mathbf{r}_s^2 \{ Y_{2,-\mu}(\underline{\theta}_s, \underline{\phi}_s) + (\mathbf{r}_p/\mathbf{r}_s)^2 Y_{2,-\mu}(\underline{\theta}_p, \underline{\phi}_p) - 2 \left(\frac{10\pi}{3}\right)^{1/2} \times (\mathbf{r}_p/\mathbf{r}_s) \sum_{\xi} C(1, 1, 2; \xi, -\mu - \xi) Y_{1,\xi}(\underline{\theta}_p, \underline{\phi}_p) Y_{1,-\mu-\xi}(\underline{\theta}_s, \underline{\phi}_s) \}. \quad (\text{A } 4)$$

In order to obtain the desired result, we must multiply (A 4) by  $\mathbf{r}_{ps}^{-5}$  to calculate this one can expand  $\mathbf{r}_{ps}^{-1}$  in spherical harmonics [20].

$$\frac{1}{\mathbf{r}_{ps}} = \frac{1}{\mathbf{r}_s} \sum_{l=0}^{\infty} \left(\frac{\mathbf{r}_p}{\mathbf{r}_s}\right)^l \left(\frac{4\pi}{2l+1}\right) \sum_{m=-l}^{+l} (-1)^m Y_{l,-m}(\underline{\theta}_p, \underline{\phi}_p) Y_{l,m}(\underline{\theta}_s, \underline{\phi}_s). \quad (\text{A } 5)$$

One can then multiply (A 5) by itself and the pairs of spherical harmonics involving the same angles can be expressed as a sum over single spherical harmonics. This is done using (R4.30) and (R4.25). One then multiplies the result by (A 5) three more times until  $\mathbf{r}_{ps}^{-5}$  is achieved; at each step using (R4.25) to reduce the expression to a single spherical harmonic for each pair of angles  $(\underline{\theta}_p, \underline{\phi}_p)$  and  $(\underline{\theta}_s, \underline{\phi}_s)$ . This is an extremely tedious procedure and the result is 18 summations over one expression involving 16 Clebsch-Gordan coefficients (see, for example, [21]). Since we only require an expression to order  $\mathbf{r}_p/\mathbf{r}_s$ , a more practical approach is to express (using (A 1))  $\mathbf{r}_{ps}^{-5}$  in the form

$$\mathbf{r}_{ps}^{-5} = \mathbf{r}_s^{-5} \left\{ 1 - \frac{2\mathbf{r}_s \cdot \mathbf{r}_p}{\mathbf{r}_s^2} + \frac{\mathbf{r}_p^2}{\mathbf{r}_s^2} \right\}^{-5/2}. \quad (\text{A } 6)$$

Dropping the term in  $\mathbf{r}_p^2/\mathbf{r}_s^2$  in (A 6) and expanding the remainder in a Taylor expansion, gives, to order  $\mathbf{r}_p/\mathbf{r}_s$

$$\mathbf{r}_{ps}^{-5} = \mathbf{r}_s^{-5} \left\{ 1 + 5 \frac{\mathbf{r}_s \cdot \mathbf{r}_p}{\mathbf{r}_s^2} \right\}. \quad (\text{A } 7)$$

Finally, the inner product in (A 7) is expressed in terms of spherical harmonics (see R5.2) to give

$$\mathbf{r}_{ps}^{-5} = \mathbf{r}_s^{-5} \left\{ 1 + 5 \left(\frac{4\pi}{3}\right) \frac{\mathbf{r}_p}{\mathbf{r}_s} \sum_{\xi} (-1)^{\xi} Y_{1,\xi}(\underline{\theta}_p, \underline{\phi}_p) Y_{1,-\xi}(\underline{\theta}_s, \underline{\phi}_s) \right\}. \quad (\text{A } 8)$$

The desired result is (A 4) times (A 8). The leading term of (11) comes from the leading terms in (A 4) and (A 8). The term in  $\mathbf{r}_p/\mathbf{r}_s$  is given by the third term in (A 4) times the first term in (A 8) plus the first term in (A 4) times the second term in (A 8). This gives

$$r_p r_s^{-4} \sum_{\xi=-1}^{+1} Y_{1,\xi}(\theta_p, \phi_p) \left\{ (-1)^\xi \left( \frac{20\pi}{3} \right) Y_{1,-\xi}(\theta_s, \phi_s) Y_{2,-\mu}(\theta_s, \phi_s) - 2 \left( \frac{10\pi}{3} \right)^{1/2} C(1, 1, 2; \xi, -\mu - \xi) Y_{1,-\mu-\xi}(\theta_s, \phi_s) \right\}. \quad (\text{A } 9)$$

The product of spherical harmonics in the first term inside the brackets in (A 9) can be expressed in terms of a sum of spherical harmonics of order 3 and 1 (see R4.32). When this is done, the term involving the spherical harmonic of order 1 is identical and of opposite sign to the second term in equation (A 9) and the two cancel. One is then left with a single term involving a spherical harmonic of order 3 as indicated in the second term in (11).

The author sincerely thanks Professor Stan Clough, Dr. Jethro Hill and Dr. Stuart Nugent at the University of Nottingham for many very helpful discussions and Professor Myer Bloom and Dr. Irving Ozier at the University of British Columbia for some helpful suggestions. This work is supported in part by the National Research Council of Canada through a Post-Doctoral Fellowship and in part by the Science Research Council through the research grant of Professor Clough.

#### REFERENCES

- [1] CLOUGH, S., HoBSON, T., and NuGENT, S.M., 1975, J. Phys. C, 8, L95.
- [2] CLOUGH, S., and HILL, J. R., 1976, J. Phys. C, 9, L645.
- [3] CLOUGH, S., and HILL, J. R., 1975, J. Phys. C, 8, 2274.
- [4] BECKMANN, P. A., and CLOUGH, S., 1977 ( to be published).
- [5] CLoUGH, S., and HoBSON, T., 1974, J. Phys. C, 7, 3387.
- [6] NUGENT, S. M., 1976, Ph.D. Thesis, University of Nottingham ( unpublished).
- [7] NUGENT, S. M., 1977, J. Phys. C, 10, 781.
- [8] BECKMANN, P. A., and CLOUGH, S., 1977, J. Phys. C, 10, L231.
- [9] CLOUGH, S., HILL, J. R., and HoBSON, T., 1974, Phys. Rev. Lett., 33, 1257.
- [10] BECKMANN, P. A., CLOUGH, S., HENNEL, J. W., and HILL, J. R., 1977, J. Phys. C, 10, 729.
- [11] MAZE, M., and RERAT, C., 1964, Cr. hebd. Seanc. Acad. Sci. Paris, 259, 4612.
- [12] FREED, J. H., 1965, J. chem. Phys., 43, 1710.
- [13] ABRAGAM, A., 1961, The Principles of Nuclear Magnetism (Oxford University Press).
- [14] TINKHAM, M., 1964, Group Theory and Quantum Mechanics (McGraw-Hill).
- [15] APAYDIN, F., and CLOUGH, S., 1968, J. Phys. C, 1, 932.
- [16] EMID, S., WIND, R. A., and CLOUGH, S., 1974, Phys. Rev. Lett., 33, 769.
- [17] RosE, M. E., 1957, Elementary Theory of Angular Momentum (John Wiley & Sons).
- [18] FANO, U., and RAchA, G., 1959, Irreducible Tensor Sets (Academic Press Inc.), Chap. V and Appendix J.
- [19] YI, P., Ozi ER, I., and ANDERSON, C. H., 1968, Phys. Rev., 165, 92.
- [20] LEVY, P.M., 1969, Phys. Rev., 177, 509.
- [21] ZEIDLER, M. D., 1975, Malec. Phys., 30, 1441.



Figures:

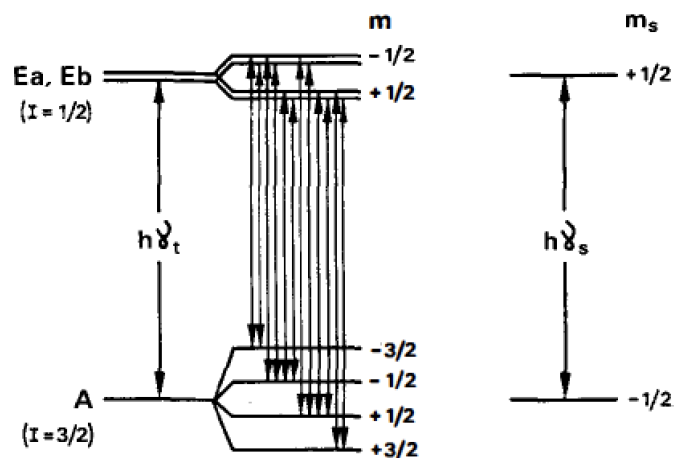

Figure 1. Schematic energy level diagram for a methyl group electron system. The methyl group tunnelling states are labelled by  $T = A, Ea$  and  $Eb$  and have associated with them a total nuclear spin  $I$  as shown. The  $Ea$  and  $Eb$  states are degenerate. The nuclear and electron Zeeman states characterized by  $m$  and  $m_s$  are also shown. The transition indicated by the heavy arrow is driven by the intermolecular dipole-dipole interaction. The 12 nuclear transitions which constitute the tunnelling transition are shown. There are four each from  $\Delta m = -1, 0$  and  $+1$ . This methyl-group electron flip-flop transition is resonant when  $\nu_s - \nu_t - \Delta m \nu_n \sim \nu_s - \nu_t = 0$ , where  $\nu_t$  is the tunnelling frequency and  $\nu_s$  and  $\nu_n$  are the electron and proton Larmor frequencies respectively.

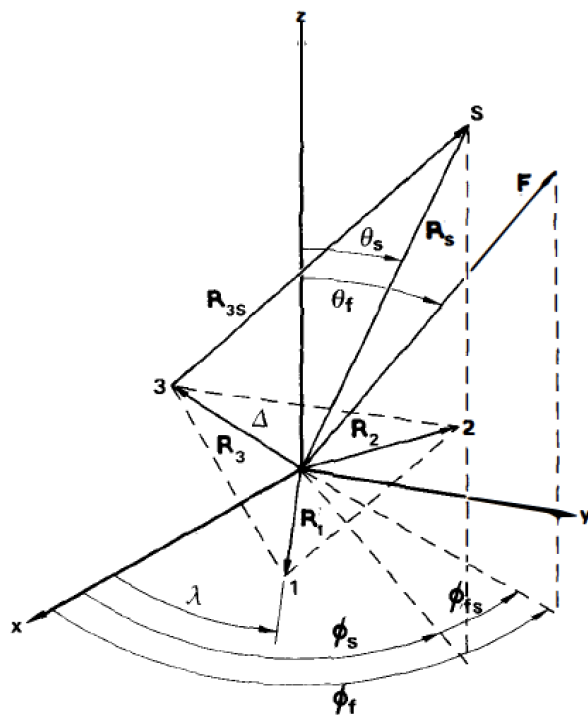

Figure 2. The molecular fixed reference frame (MFF). The methyl-group proton coordinates lie in the  $xy$  plane and are specified by  $\mathbf{R}_p$ ,  $p=1, 2, 3$ . In polar coordinates,  $\mathbf{R}_p=(\Delta, \pi/2, \phi_p)$ , where  $\phi_1=\lambda$ ,  $\phi_2=\lambda+2\pi/3$  and  $\phi_3=\lambda-2\pi/3$ . The electron coordinate  $\mathbf{R}_s=(R_s, \theta_s, \phi_s)$ . The  $z$ -axis of the space-fixed frame (SFF) is parallel to the applied magnetic field  $\mathbf{F}$  and is specified in MFF by the angles  $\theta_f, \phi_f$ . The vector  $\mathbf{R}_{ps}$  goes from the  $p$ th proton coordinate to the electron coordinate. The case of  $p=3$  is shown. The angles  $\theta_{ps}, \phi_{ps}$  specifying  $\mathbf{R}_{ps}$  in MFF are not shown.