

Organizational Anomie, Professional Self-Concept and Organizational Support Perception: Theoretical Model Evidences for Management

Antonio Fandiño, PhD^{a b}

^a Department of Quantitative Methods for Management and Economics - ISCTE-IUL

^b Department of Accounting Sciences and Management
Rural Federal University of Rio de Janeiro – UFRRJ

Souza, Marcos Aguiar, PhD^{a b}

^a Department of Quantitative Methods for Management and Economics - ISCTE-IUL

^b Federal University of Rio de Janeiro, Psychology Institute, UFRJ

Nilton Soares Formiga, PhD

Paraiba Internatinal College

Rui Menezes, PhD

Department of Quantitative Methods for Management and Economics - ISCTE-IUL

Sonia Ricardo Bentes, PhD^{a b}

^a Department of Quantitative Methods for Management and Economics - ISCTE-IUL

^b ISCAL – Lisbon Institute of Management and Accounting

Abstract

Employees need reliability and predictability in the organization's moral order to properly engage in labor, which has become critical for organizations' success. Its absence creates a rupture in the firm's capacity to thrive in the market, named anomie. With the aim of looking more deeply into this subject, we have studied the relationship between anomie and social support at work, as well as professional self-concept, to understand and measure the cause-and-effect process. For this purpose, a model has been created to test this hypothesis, which has been analyzed through Structural Equation Modeling. The scales used have already been validated by other researches. The results provide evidence that the proposed model is suitable to identify and measure the relationship between the studied variables, and showing the level of impact that occurs on the system, created by organizational anomie, on social support at work and professional self-concept, together with their component parts.

Keywords: organizational anomie, professional self-concept, organizational support perception, structural equation model.

1. Introduction

The need to create an environment in which a sense of trust in the moral order that prevails in the labor network, and in the organizational structure where it occurs, has led scholars to amplify their comprehension of normative statements (norms) and their consequences, the moral behavior in the workplace; as well as the absence of these from the workers' point of view, named as anomie (Martin, Johnson, and Cullen, 2009). In view of this anomie has become a focus of much research to understand it from different perspectives whether at a societal or an individual level, as anomie is related to diverse elements such as cognitive and emotional factors, and beliefs that can be triggered by certain social condition interactions depending on the personal experiences of each individual.

With the purpose of amplifying the understanding of this condition in the organizational dynamic, on this paper it has studied the relation between anomie and work social support as well as professional self-concept. For this, a theoretical model has been hypothesized that organizational anomie acts not only on social support at work but also on professional self-concept. This approach has come to light through previous research on papers, some of them cited in the reference section and empirical observations of different organizations by the researchers.

As an analysis instrument and to test the hypothesis, a recursive structural equation model was used, both to verify its existence, and if positive, to examine the variables' interactions. The instrument has been applied to groups of workers from the public and private sectors to encompass a representative work environment reality sample.

2. Anomie and Social Norms

It is a commonplace to state that man is a social being. Since the beginning, group relationship has allowed mankind to deal with adversities, be they a hostile environment or other groups. This perspective highlights the importance of social norms to define what the desired behaviors are in a certain society. Despite the fact that what is right or wrong in terms of individual behavior can differ from one society to another, all societies have as a rule of thumb the understanding that misapplications of their normal patterns are unacceptable (Sherif, 1936).

According to that scholar, it is from social norms that people learn what society expects from them in regard to traditions, social patterns, rules, values, and what is permissible or forbidden. In other words, norms determine which behavior is acceptable and expected (Miller and McFarland, 1991). Social norms can also be understood as group-held beliefs, which force members to behave in a given context, even when they do not agree with them, to grant group cohesion (Prentice and Miller, 1993).

From this perspective, it is important to consider how norms are perceived by the members. If they are understood as inefficient or non-existent, it represents an anomie state, a relatively normless state, where rules have been eroded. Durkheim (1951) in 1897 was the first one to identify this lack of regulating means that ensure co-operation among individuals in different social roles. The core point of this theory is a lack/absence of interactions among people, who no longer identify themselves as participants in a common organization (Besnard, 1988), producing a flawed co-ordination among its members, which weakens solidarity, and increases social class conflicts. All of this results in the breakdown of social bonds (Cohen, 1997).

Societies create adjustable limits to their members' goals in a way that does not compromise their motivations. It means that everyone has a reasonable chance to achieve his or her goals or even to seek more ambitious goals. Individuals will only restrain their desires if they realize that the collective rules are genuine. Based on this, the concept of anomie offers guidance to understand how weakness in the bases that bear social norms can create a social pathology, making it difficult to predict personal behavior, because individuals would tend to act according to their own norms as they do not trust in collective rules to achieve their private goals (Durkheim, 1951; 2004).

Merton (1968) and Sigelmann (1981) address the idea that societies differ from each other in the relative emphasis they place on personal goals and standards that regulate the legitimate pursuit of these goals. It implies that anomie is the result of dysfunction between prescribed cultural goals and socially institutionalized means to reach these.

Merton (1968) considers that anomie is experienced by an individual when there is a discrepancy between goals and social means. In this sense, he identifies different individuals' forms of adaptation to a given society, useful for open perspectives to deal with this reality, which are: conformity (perfect adaptation of an individual to society); innovation (development strategies to reach socially established goals, when the available means are understood as inefficient); ritualism (compliance with social standards, even when people do not believe in them, because of a strong internalization of societal means); withdrawal (rejection of goals and means); and rebellion (non-passive rejection of goals and means, and actively seeking the establishment of new goals and more satisfying means).

2.1 Organizational Anomie

In the work environment, a societal microcosm, where relationships are the ties of work flow, identifying and exploring anomie provides insights into how individuals' behavior is impacted by this normless state, rules' discontinuity, and / or the end of behavioral guidelines, which creates uncertainty about what is right or wrong in

an organizational context (Coser 1964, Passas, 1999). Anomie can be brought into an organization by anomic conditions that result from periods of adversity, where goodwill among members gives way to egoistic behaviors "deinstitutionalizing the normative control system reflected in its ethical climates" (Martin et al., 2009, p.122). The most common consequences of anomie are high turnover, low morale among employees, and a tendency to engage in corrupt behavior. All of those factors put together tend to cause organizations to collapse (Manrique and Espinoza Rodrigues, 2007).

Organizational anomie can be transient or permanent. The first one appears during transition periods, as e.g. mergers, acquisitions, and downsizing, causing behaviors deviant from current desired organizational norms due to the loss of previous references. In general, this period precedes a new organizational structure and way of management (Tsahuridu, 2006). The second one happens in a context where employees cannot achieve their personal aspirations or when this is only possible if they belong to a certain group (Parales-Quenza, 2008). Therefore, the efficiency of the factors that reinforce social cohesion diminishes, creating a decoupling between formal norms and those really applied. In this reality, difficulties in personal adaptation become frequent, leading to feelings of loss of orientation, insecurity, marginalization, unreal expectations, and these challenge the legitimacy of core values hitherto defended (Atteslander, 2007).

Considering the context where organizational norms become inadequate or insufficient for their own reality, a new theory named Red Tape has helped to explain the probability of rules becoming effective. According to this theory the probability of rules becoming effective depends on the combination of: (1) written requirements; (2) with valid means-ends relationships, which; (3) employ optimal controls, that; (4) are consistently applied, and have; (5) purposes understood by stakeholders (DeHart-Davis 2009). It means any entities or people who are affected in the present or in the future by an organization's performance, e.g. persons, groups, and other organizations.

Elaborating from these concepts, formal norms in opposition to informal norms cause a negative impact on organizational performance (Nee, 1998), which makes anomie a relevant concern not only for employees' welfare, but also for successful management. The present research is focused on the development of a model to identify the organizational anomie impact, specifically when the norms adopted by organizations do not represent the reality lived by their members, as well as measure the relationship between them.

3. Professional Self-Concept and Organizational Support Perception

The notion of self-concept is considered central to understanding individual behavior, as it refers to a self-image, so that an individual can evaluate himself, serving as a reference for appraising various situations and contexts experienced by an individual (Rogers, 1977). Its theoretical main construct states that it is formed by a person's perceptions, which can range from the most global to the most specific, covering various aspects of people's lives (Souza and Puente-Palacios, 2007). Thus, although certain aspects may be modified with relative ease by environmental influences, others are more resilient, requiring more time for them to be modified. In this sense, variations in individuals' self-concept can be identified according to the situation or even according to the development period in which it is located (Costa, 2002).

Baumeister (1999, p.13) describes self-concept as an "... individual's belief about himself or herself, including the person's attributes and who and what the self is". This means that its content is formed by beliefs and self-assessments that arise from questions like "who am I?" and "how do I feel about myself?", and it can be studied from its content or even structure, which allows us to investigate and understand its influence on variables related to psychological adjustment, one of the focuses of this research (Campbell, Assanand e Di Paula, 2003).

As a sub-group of this term, professional self-concept is a multi-dimensional construct that encompasses different perceptions that an individual has about oneself in labor contexts (Souza and Puente-Palacios, 2007). An ongoing self-appraisal about one's own professional skills, knowledge and values are the main mechanisms that make up this concept. Another aspect to be considered in the construct is the role of modeling and repetition, and also interaction with the professional group as a reference to define and clarify a professional role (Kelly, 1992).

As pointed out above this theory brings a relevant piece of information for a deeper understanding of labor network relationships through labor environment characteristics, making it required in the present instrument.

Organizational support perception is the last significant variable defined for this study. It is based on the premise that an employee develops a global belief in relation to the overall degree in which an organization esteems

him/her and takes care of his/her welfare (Richardson et al, 2008; Byrne and Hochwarter, 2008; Dawley, Andrews and Bucklew, 2008; Tamayo and Abbad, 2006). This perception forms and develops through multiple exchange settings between employee and organization (Diliello et al 2011, Jawahar and Hemmasi, 2006).

In this context, organizational support perception appears as a relevant construct to explain individual behavior inside an organization as well as an account of different levels in employees' health and quality of life. It is timely to state that it has been investigated in relation to different variables associated with both performance and health/quality of life at work, being highlighted in this aspect of organizational commitment and employees' locus of control (to the extent that people believe they can control events in their lives) which were identified as important variables to create engagement between organizational actors (Aubé, Rosseau and Morin, 2007).

As a final note, the relation between organizational support perception and professional self-concept is not self-evident, but it seems to be justified given that both constructs refer to processes that are cognitively developed on the basis of influences, arising from the organizational context to which individuals belong.

4. Research Instruments and Methodology

4.1 Participants

The sample consisted of 282 workers from different companies in Rio de Janeiro State, from 19 to 68 years of age, of which 184 belonged to private companies and 98 public companies, 59% were women, 54% were single and 49% of them had an incomplete higher education level. This sample is not probabilistic; it has been defined as casual, because the people who were queried had been asked previously to co-operate by answering the questionnaire.

4.2 Instruments

The instrument applied in this research was devised in four parts. The first one consisted of items that asked about participants' sex, gender, age, marital status, education level, children, company sector (public or private), and seniority. The second part is the organizational anomie scale, which was set up to measure workers' belief that organizational norms are inefficient, and fail to provide guidance for proper behavior in the organization. The instrument in this primal form was made from 19 items hypothetically considered as one factor, in a five point Likert scale, ranging from strongly disagree to strongly agree.

The third part consists of a professional self-concept scale (Souza and Puente-Palacios 2007). According to the authors, the scale has 28 items split up into 4 factors: Achievement, Competence, Self-Confidence and Health. Achievement refers to individual's perception of their career success, ambitions, and ideals achieved by his/her own work (8 items). The Competence factor has 9 items that refer to individual's perception of their self-confidence level to do his/her work. Health (5 items) is about how the work and activities/aspects related to it affect his/her health.

Therewith only the three first aspects were considered as central for professional self-concept, because of that in this research health questions were omitted; therefore, the final instrument contains 23 items.

Lastly, the fourth part is comprised of an Organizational Support Perception Scale (EPSO), which was validated by Siqueira, Brazilian sample questionnaire (1995). The instrument has the goal to measure employees' perceptions of how much an organization is concerned with his/her welfare (9 items).

4.3 Procedures

The questionnaire was given out in universities and organizations in Rio de Janeiro State. Before questionnaires were filled in, the research goals were made clear to the respondents. It is an anonymous questionnaire and completed in privacy to safeguard the respondents privacy. The research was approved by UFRJ's Ethics Committee on Research. All of the procedures adopted in this research followed the guidelines set out for Brazil in Resolution 196/96 from the National Health Council and in Resolution 016/2000 from the Federal Council of Psychology on human research.

A standard, scientific, and ethical data collection procedure was sought, which consisted of applying measurements in a collective or individual way in companies in Rio de Janeiro. Experienced researchers were made responsible for data collection, and were presented to companies as people interested in looking into workers' opinions and behaviors in the situations presented in the instruments.

Voluntary participation was requested through asking people to respond to a short questionnaire and after being made aware of the research's participation conditions, to sign a consent form. They were told that there were no right or wrong answers, and to respond individually. Everyone was guaranteed anonymity and that their answers would be treated as a whole.

Although the test is self-administered, coming with the necessary instructions to give answers, the researchers were present throughout the whole process, to resolve any doubts or provide any necessary clarifications. An average time of 30 minutes was sufficient to complete the activity.

The SPSS statistics package (version 16.0) for windows was used for the analysis of the research data. Descriptive statistics (central trend and dispersion) were computed. The following indicators for the Structural Equation Model (SEM) were considered according to the adequacy of subjective fit.

This statistics program serves to present, in a more robust way, psychometric indicators that aim for a higher level of adaptation and accuracy in the developed scale, as well as making possible the design of this study's planned theoretical model. Thus the Structural Equation Model (SEM)'s statistical indicators, effected using AMOS GRAPHICS version 16, were the following:

- χ^2 (x squared) that tests the probability of the theoretical model adjusting to the data. Therefore, the bigger this value, the worse the adjustment. This has been little used in the literature, it being more common to consider its ratio in relation to degrees of freedom ($\chi^2/g1$). In this case, values up to 5 indicate a suitable adjustment;
- Root Mean Square Residual (RMR) that indicates the theoretical model's adjustment to the data, to the extent that the difference between the two reaches zero. For the model to be considered well adjusted, the value must be less than 0.05;
- Goodness-of-Fit Index (GFI) and the Adjusted Goodness-of-Fit (AGFI) are analogous to R^2 in multiple regression. Therefore they indicate the proportion of variance-co-variance matrix of the data explained by the model. These vary from 0 to 1, with values between 0.80 and 0.90 or higher, indicating a satisfactory adjustment (Hair et al., 2005; Bilich, Silva and Ramos, 2006);
- Comparative Fit Index (CFI) – compares the estimated model and the null model, considering values closer to 1 as indicators of a satisfactory adjustment (Joreskog and Sorbom, 1989; Hair et al., 2005);
- NFI that is characterized as being a comparative measure between the proposed and null models and that an incremental adjustment, which varies from zero to 1 (one). Values of 0.90 or higher can be considered acceptable;
- Root-Mean-Square Error of Approximation (RMSEA) with its confidence interval of 90% (CI90%) is considered an indicator of adjustment fit. High values indicate that a model is not well adjusted. The ideal RMSEA is assumed to be situated between 0.05 and 0.08, though values of up to 0.10 are acceptable (Kelloway, 1998; Garson, 2003).

A variance analysis was also carried out, with a view to evaluating the differences in the respondents' average scores in relation to organizational anomie (VI), professional self-concept (VD), and social support at work (VD).

5. Results and Discussion

This study has the objective of establishing the influence of organizational anomie on social support at work and on professional self-concept. To this end, a recursive structural equation model was considered and analysis and modeling of structural equations was performed using the program AMOS 21.0 for the hypothesized model.

In figure 1, with the appropriate modifications made in the error adjustments, a suitable model was found. This presented the following statistical basis: $\chi^2/g1 = 1.22$, RMR = 0.04, GFI = 0.96, AGFI = 0.93, CFI = 0.99, TLI = 0.98, RMSEA = 0.04 (0.01-0.04). The weights (overruns) that explain the model of the variable considered organizational anomie is negatively associated with organizational support ($\beta = -0.71$) and with professional self-concept ($\beta = -0.37$), these last two variables being positively associated ($\beta = 0.30$). All of the overruns (Lambdas $\beta\beta\beta$) are within expected limits $|0 - 1|$, meaning that there are no proposed estimation problems, because all were statistically different to zero ($t > 1.96$, $p > 0.05$).

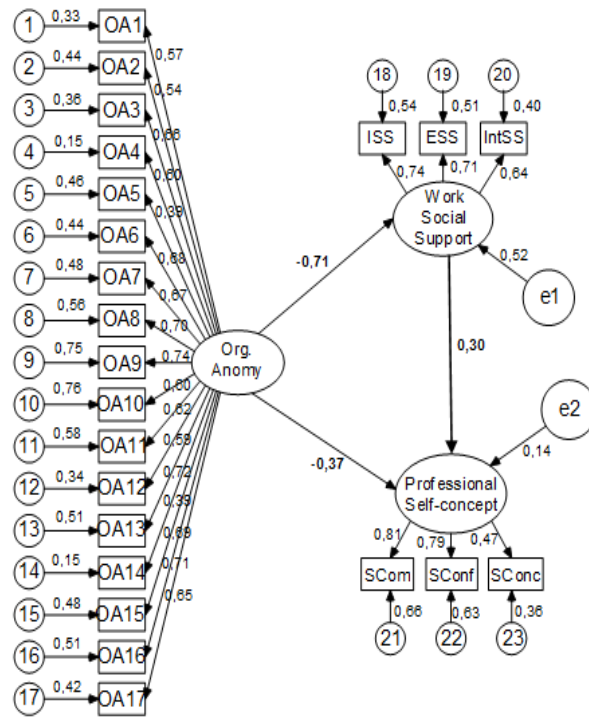

Figure 1: Structural Equation Model

The analysis of prediction estimates, made through regression analysis in the proposed theoretical model, has indicated that all variables are significant. Furthermore, the alleged model has revealed Work Social Support as mediator variable between Organizational Anomie and Professional Self-Concept (Table 1).

Table 1: Prediction estimate indicators between model variables

Variables		Estimates	S.E.	C.R	p <
WSS	<--- AO	-,764	,080	-9,511	0,01
PSC	<--- AO	-,373	,072	-4,928	0,01
PSC	<--- WSS	,324	,076	4,240	0,01

In order to eliminate any doubt two specific models were created, taking in account the linearity between each pair of the model’s variables. Thus, it examined the association between them. Firstly, with Organizational Anomie and Work Social Support, the results show the following statistical indicators ($\chi^2/df = 4,52$, RMR = 0.09, GFI = 0.79, AGFI = 0.74, CFI = 0.79, TLI = 0.76, RMSEA = 0.11 (0.10-0.12)). Secondly, with Org. Anomie and Professional Self-Concept, the verified results show ($\chi^2/df = 4,47$, RMR = 0.10, GFI = 0.78, AGFI = 0.72, CFI = 0.78, TLI = 0.76, RMSEA = 0.11 (0.10-0.12)).

When these indicators are compared with those observed in the recursive model, which prioritizes only one explanatory direction between variables, it stands out that they are lower than those in the non-recursive model. It allows us to consider it as systemic due to associations between variables, which besides being positive, indicate that the individual who shows a high score in organizational anomie, will probably score highly (although negatively) in organizational support as well as professional self-concept. Table 1 shows that the hypothesized model’s estimates are meaningful.

Observing the representation of the model obtained, it is possible to reflect that organizational anomie had a negative influence on both professional self-concept and the perception of social support at work; the influence being significant. Beyond this, it was observed that the perception of social support at work and professional self-concept were positively linked.

Considering the theoretical model, with the existence of anomie in an organization, it is probable that this can harm the organization's functionality, as well as people within the organization's self-image. It must be highlighted, however that these last two constructs (support and self-concept) support each other, both being inhibited by the presence of anomie. This being the case, it is necessary to highlight that the influence of anomie on the perception of social support at work, as considered initially in the study, is justified when faced with the characteristics of anomic organizational contexts, in which social relations end up being undermined, because an individual doesn't know what to expect from his superiors, partners and subordinates (Tsahuridu, 2010). Such an influence was identified in each of the factors used to measure social support at work (emotional-social, instrumental and informational). Thus, in relation to social-emotional support, it was seen that organizational anomie exercises a negative influence, as the factor refers to the employee's perception that there are people in the organization in whom they can trust, and that concerned with the well-being of others. Referring to interpersonal relations, feelings such as comprehension, attention and concern stop being identified in the organization's personnel.

The negative relationship between organizational anomie and instrumental social support indicates that in organizations characterized by a high degree of anomie, there is a perception that there is no support from other people in the sense of providing means for the development of daily professional activities. There is a perception that the giving or lending of material and equipment comes to occur less intensely.

Finally, in anomic organizational contexts there is a perception that the information necessary for the performance of daily professional activities circulate less intensely. Thus, situations in which there are clarifications, suggestions and orientations exchanged among workers are less frequently observed. It should be pointed out that organizational support also acts as a mediating variable on professional self-concept. As a consequence of this the influences received from organizational anomie are retransmitted to self-concept, through the dismantling of formal and informal assistance networks and support inside the organization for work to be done. The relationship between organizational anomie and professional self-concept was also negative in relation to the three factors. Such a relationship is justified by the literature, as professional self-concept generally refers to the image that individuals have of themselves regarding their performance at work. Thus, the results obtained are justified, indicating that the existence of a high degree of organizational anomie has a negative influence on professional self-concept for each of the factors considered (Performance, Competence and Self-Confidence). As this study has shown, in organizations with a high degree of organizational anomie, there are negative repercussions on performance, leading individuals to less intensely perceive their professional successes and their aspirations related to their career and their work. Competence is also negatively influenced, preventing individuals from having a favorable view of their capabilities, abilities, and skills for doing work.

Finally, employee's self-confidence is diminished, undermining the performance of day-to-day professional activities. A positive relationship was obtained between social support at work and professional self-concept, as was hypothesized. Such a relationship is justified from the studies undertaken, which show that the two variables are associated with several desirable phenomena in organizations, especially health and well-being at work (Diliello et al 2011, Siqueira, 2008; Brough, 2005; Friedman and Faber, 1992; Cobb, 1976).

Considering these results it is possible to point out that the proposed theoretical model has been corroborated.

This presented psychometric indicators for the structural modeling between the variables, accepted in statistical literature (Hair et al, 2005; Joreskog and Sörbom, 1989); an association being found between organizational anomie, social support at work and professional self-concept.

Based on this model we initially opted for a test on independent samples relating to the highlighted variables, with the aim of evaluating the average scores for public and private employees. The results were as follows: in respect of organizational support, the employees of private companies presented a higher average score ($M = 9.96$, $DP = 2.29$) than the employees of public companies ($M = 9.04$, $DP = 2.06$) [$t(280) = -3.32$, $p < 0.01$, $IC_{95\%} -0.46$ a -0.37]; while for professional self-concept, the employees of private companies had higher scores ($M = 11.63$, $DP = 1.61$) than the public sector employees ($M = 10.04$, $DP = 1.80$) [$t(280) = -2.81$, $p < 0.01$, $IC_{95\%} -0.79$ a -0.03]. In relation to organizational anomie there were no significant results. Secondly an Anova (variance analysis) was done, in association with a Sheffé post-hoc test, in order to evaluate the differences in the average scores between the dependent and independent variables. Significant results were observed, too.

6. Conclusions

From this results obtained in this study it is possible to state that the proposed model is suitable for explaining and measure the relationship between organizational anomie, professional self-concept and social support at work.

Considering that it is desirable that an organization be regulated by norms, so that it displays a high degree of predictability about what will happen in an organization; that there be a guarantee that things happen in the expected way, as proscribed by norms. Thus organizational anomie is an important variable to be considered, because it can impair all the organization's efforts. When the workers don't know what to expect from an organization and its members, there can be a tendency for group, or even personal norms, to develop. Personal relationships between group members are damaged, and this can cause conflicts between certain sectors, or even between workers in the same sector. Considering specifically the variables dealt with in this study, the damage observed to social support at work and professional self-concept brings undesirable consequences to an organization, as has been widely discussed in the literature.

The results strongly suggest the necessity of managers and professionals paying attention to the real applicability of organizational policies and to guarantee the effectiveness of the norms that regulate an organization, taking special care with situation that show the weakness of organizational norms. This becomes more critical, the more complex the organization's production and its dependence on its employee's inherent knowledge (intellectual capital) for creating competitive advantage in the form of products and/or new strategies for the market are.

We suggest that more studies be done that consider specific organizations, so as to allow the use of different investigative methodologies, leading to a deeper understanding of organizational anomie and its influence on other organizational phenomena.

References

- Atteslander, P. (2007) "The impact of globalization on methodology.Measuring anomie and social transformation." *International Review of Sociology*, 17(3): 511-524.
- Aubé, C., Rosseau, V., Morin, E. M. (2007) "Perceived organizational support and organizational commitment. The moderating effect of locus of control and work autonomy." *Journal of Managerial Psychology*, 22(5): 479-495.
- Baumeister, R.F. (1999) (Ed.) *The Self in Social Psychology*. Philadelphia, PA: Psychology Press, Taylor and Francis.
- Besnard, P.: (1988) 'The True Nature of Anomie', *Sociological Theory* 6(Spring): 91–95.
- Bilich, F.; Silva, R., and Ramos, P. (2006) "Análise de flexibilidade em economia da informação: modelagem de equações estruturais." *Revista de Gestão da Tecnologia e Sistemas de Informação*, 3(2):93-122.
- Byrne, Z. S. and Hochwarter, W. A. (2008) "Perceived organizational support and performance: Relationships across levels of organizational Cynicism." *Journal of Managerial Psychology*,23(1):54-72.
- Campbell, J. D.; Assanand, S., and Di Paula, A. (2003) "The Structure of the Self-Concept and Its Relation to Psychological Adjustment." *Journal of Personality*, 71(1) 115-140.
- Cohen, A. K. (1997) "An elaboration of anomie theory." In N. Passas and R. Agnew Eds., *The Future of Anomie Theory*: 54-61. Boston: Northeastern University Press.
- Coser, L. A. (1964) *Sociological Theory: A Book of Readings*, 2nd edition, New York, NY: MacMillan Company.
- Costa, P. C. G. (2002) "Escala de Autoconceito no Trabalho: Construção e Validação." *Psicologia: Teoria e Pesquisa*, 18(1): 75-81.
- Dawley, D. D., Andrews, M. C. and Bucklew, N. S. (2008) "Mentoring, Supervisor Support, and Perceived Organizational Support: What Matters Most?" *Leadership & Organization Development Journal*, 29(3), 235-247.
- DeHart-Davis, L. (2009) "Green tape: A theory of effective organizational rules." *Journal of Public Administration Research and Theory*, 19(2), 361-384.
- Diliello, T. C; Houghton, J. D; and Dawley, D. (2011) "Narrowing the creativity gap: the moderating effects of perceived support for creativity." *The Journal of psychology*, 145(3): 151-72.
- Durkheim, E. (1951) *Suicide*, originally published in 1897, Simpson G. translation, New York:Free Press.
- Durkheim, E. (2004) *Da Divisão Social do Trabalho*,originally published in 1894, São Paulo: Ed. Martins Fontes.
- Garson, G. D. (2003) PA 765 Statnotes: An online textbook, available at:

<http://www2.chass.ncsu.edu/garson/pa765/statnote.htm~>, accessed 10/29/2009.

- Hair Jr., J. F., Anderson, R. E., Tatham, R. L. and Black, W. C. (2005) *Análise multivariada de dados*, 5th ed. Porto Alegre: Bookman.
- Jawahar, I. M., and Hemmasi, P. (2006) "Perceived organizational support for women's advancement and turnover intentions: The mediating role of job and employer satisfaction." *Women in Management Review*, 21(8) 643-661.
- Jöreskog, K. G., and Sörbom, D. (1989) *LISREL7, A Guide to the Program and Applications*, SPSS Publications.
- Kelly, B., (1992) "The professional self-concept of nursing under-graduates and their perceptions of influential forces." *Journal of Nursing Education*, 31(3): 121-125.
- Kelloway, E. K. (1998) *Using LISREL for structural equation modeling: A researcher's guide*. Thousand Oaks, CA: Sage Publications.
- Manrique de Lara, Z. M., and Espinoza-Rodriguez, T. F. (2007) "Organizational Anomie as Moderator of the Relationship between an unfavorable attitudinal environment and citizenship behavior (ocb): An empirical study among university administration and services personnel." *Personnel Review* 36(6), 843-866.
- Martin, K. D., Johnson, J. L., and Cullen, J. B. (2009) "Organizational change, normative control deinstitutionalization, and corruption." *Business Ethics Quarterly*, 19(1), 105-130.
- Merton, R. K. (1968) *Social Theory and Social Structure*. New York: Free Press.
- Miller, D. T. and McFarland, C. (1991) "When Social Comparison Goes Awry: The Case of Pluralistic Ignorance." Chapter 11 In Suls, J and Wills, T (eds), *Social Comparison: Contemporary Theory and Research*, Hillsdale, NJ: Erlbaum.
- Nee, V. (1998) "Norms and networks in economic and organizational performance." *American Economic Review*, 88(2): 85-89.
- Parales-Quenza, C. J. (2008) "Anomia Social y Salud Mental Pública". *Revista de Saúde Pública*, 10:658-666.
- Passas, N. (1999) "Continuities in the Anomie Tradition" In Laufer W. S. and Merton R. K. (eds.), *The Legacy of Anomie Theory*, 91-112. New Brunswick: Transaction Publishers,
- Prentice, D A and Miller, D T. (1993) "Pluralistic Ignorance and Alcohol Use on Campus: Some Consequences of Misperceiving the Social Norm." *Journal of Personality and Social Psychology*, 64(2):243-256.
- Richardson, H. A.; Yang, J.; Vandenberg, R. J.; DeJoy, D. M and Wilson, M. G. (2008) "Perceived organizational support's role in stressor-strain relationships." *Journal of Managerial Psychology*, 23(7): 789-810.
- Rogers, C.R. (1977) *Carl Rogers on personal power*. N.Y.: Delacorte Press.
- Sherif, M. (1936) *The psychology of social norms*. New York: Harper.
- Sigelman, E. (1981) "Anomia e desorganização: estudo psicológico em contexto brasileiro." Unpublished doctoral dissertation, Rio de Janeiro: ISOP.
- Siqueira, M. M. M. (1995) "Antecedentes de comportamentos de cidadania organizacional: Análise de um modelo pós-cognitivo." Unpublished doctoral dissertation, Brasília University, Brasília.
- Souza, M. G. S.; and Puente-Palacios, K. E. (2007) "Validação e Testagem de uma Escala de Autoconceito Profissional." *Psicologia*, 7(2): 95-114.
- Tamayo, N. and Abbad, G. S. (2006) "Autoconceito Profissional e Suporte à Transferência e Impacto do Treinamento no Trabalho." *RAC*, 10(3): 9-28.
- Tsahuridu, E. E. (2006) "Anomie and ethics at work." *Journal of Business Ethics*, 1-12.
- Tsahuridu, E. E (2010) "An Exploration of Factors Affecting Work Anomia." *Journal of Business Ethics*, 1-9.
- Van De Vijver, F., and Leung, K. (1997) *Methods and data analysis for cross-cultural research*. Thousand Oaks, CA: Sage Publications.

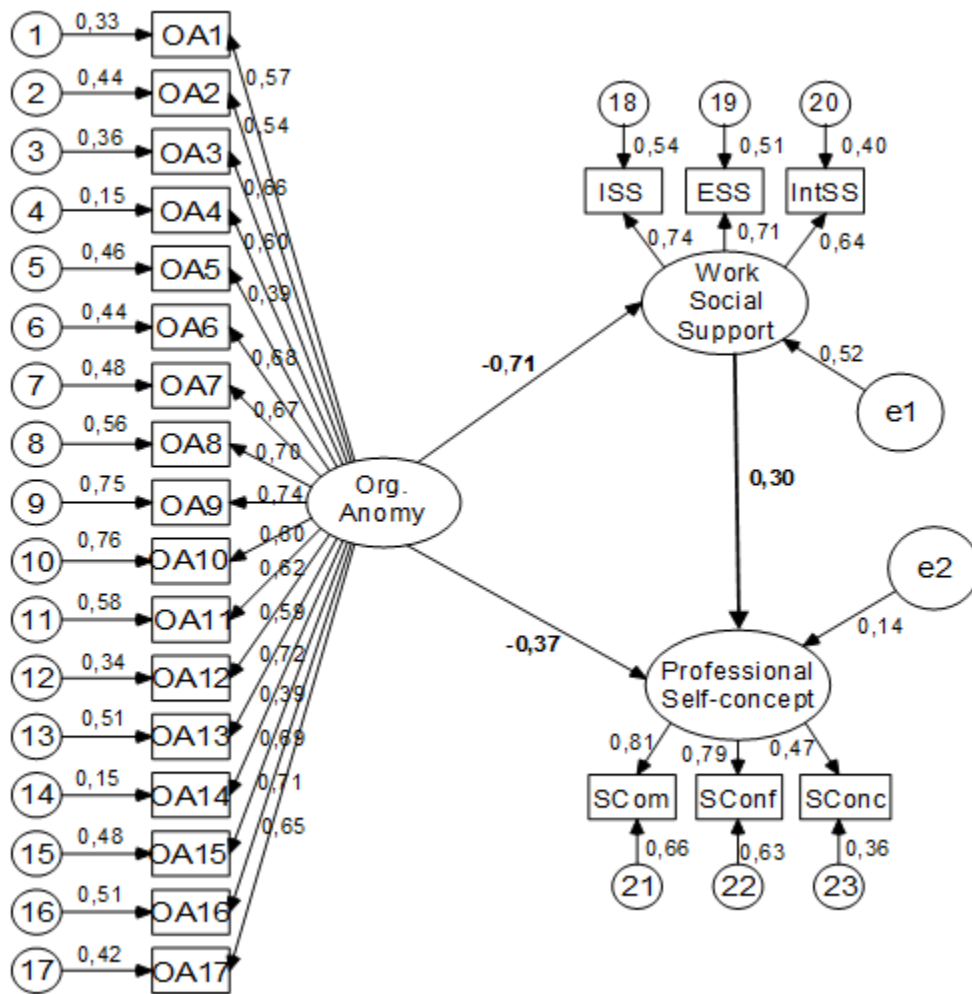

Figure 1: Structural Equation Model

Table 1: Prediction estimate indicators between model variables

	Variables	Estimates	S.E.	C.R	p <
WSS	<--- AO	-,764	,080	-9,511	0,01
PSC	<--- AO	-,373	,072	-4,928	0,01
PSC	<--- WSS	,324	,076	4,240	0,01