

Satisfaction with human resource management practices and turnover intention in a five-star hotel: The mediating role of perceived organizational support

Satisfação com as práticas de gestão de recursos humanos e intenção de turnover num hotel de cinco estrelas: O papel mediador da perceção de suporte organizacional

Ana Patrícia Duarte

Instituto Universitário de Lisboa (ISCTE-IUL), Business Research Unit (BRU-IUL), Lisboa, Portugal
patricia.duarte@iscte.pt

Daniel Roque Gomes

Instituto Politécnico de Coimbra, Escola Superior de Educação de Coimbra, , Coimbra, Portugal
drmgomes@esec.pt

José Gonçalves das Neves

Instituto Universitário de Lisboa (ISCTE-IUL), Lisboa, Portugal
jose.neves@iscte.pt

Abstract

Employees' satisfaction with human resources management (HRM) practices has been envisaged as a solid predictor of turnover; nonetheless, how these practices may influence employee's behavior is still an unclear process. There are suggestions that HRM practices may be distal determinants of turnover, as their effects may be mediated by more proximal variables such as perceived organizational support. This study empirically tested a model of research arising from these theoretical suggestions in a five-star hotel. The data collected from the survey of 152 workers were subjected to structural equation analyses. The results showed that the theoretical model had a strong fit to the data, giving empirical support to the prediction that satisfaction with HRM practices reduces turnover intentions, by increasing perceived organizational support. The importance of these results is discussed and interpreted from the point of view of strategic gains associated to the quality of HRM practices for the management of voluntary turnover.

Keywords: human resources management; turnover intention; perceived organizational support; management practices; tourism and hospitality.

Resumo

A satisfação dos trabalhadores com as práticas de gestão de recursos humanos (GRH) tem sido equacionada como preditora do *turnover*; todavia, ainda não é claro o processo pelo qual estas práticas influenciam o comportamento do trabalhador. Há sugestões de que poderão ser determinantes distais do *turnover*, sendo os seus efeitos mediados por variáveis mais proximais como a perceção de suporte organizacional. Este estudo testou empiricamente um modelo de investigação decorrente destas sugestões teóricas no contexto de um hotel de cinco estrelas. Os dados recolhidos a partir do inquérito a 152 trabalhadores foram alvo de análises de equações estruturais. Os resultados revelaram um forte ajustamento do modelo teórico aos dados, dando suporte empírico à previsão de que a satisfação com as PGRH diminui as intenções de turnover, através do incremento da perceção de suporte organizacional. A importância destes resultados é discutida e interpretada sob o ponto de

vista da mais-valia estratégica associada à qualidade das práticas de GRH para a gestão do turnover voluntário.

Palavras-chave: gestão de recursos humanos; intenção de *turnover*; percepção de suporte organizacional; práticas de gestão; turismo e hotelaria.

1. Introduction

Employee turnover continues to be a relevant issue to organizations (Cascio and Bondreau, 2011; Hom, 2011) and a timely challenge for contemporary human resource management (HRM) strategies and practices (Davidson, Timo and Wang, 2010). Turnover refers to “the voluntary cessation of membership in an organization by an individual who receives monetary compensation for participation in that organization” (Hom and Griffeth, 1995: 5) and therefore, is “a time specific event marked by physical separation from the organization” (Mobley, 1982: 111). Although turnover may have some positive impacts on overall organizational performance (e.g. removing underperforming employees), its negative impacts are well known and exceed many times the positive ones (Mobley, 1982). These include, for instance, the loss of productivity and talent and the decrease of service quality, in addition to severe costs associated to the recruitment and training of new employees (Hinkin and Tracey, 2000; Mobley, 1982). Accordingly, anticipating and managing turnover remains a key-issue of HRM.

HRM comprises a range of practices (e.g. employee recruitment and selection, training and development, performance appraisal, and career management) aligned with the company’s business strategy. HRM practices have been proposed as solid predictors of turnover (Huselid, 1995), but strong doubts still remain about how they influence employees’ quit behavior. There are suggestions that these practices may be distal determinants of turnover, as their effects may be mediated by more proximal variables. One such variable is perceived organizational support (POS) (Allen, Shore and Griffeth, 2003), which refers to employees’ beliefs about the extent to which their organization values their contributions and cares about their well-being (Eisenberger et al., 1986). This study empirically tested a research model arising from these theoretical suggestions in the context of tourism and hospitality industry. The research

model proposes that employees' POS mediates the effect of their satisfaction with HRM practices (career opportunities, compensation, training, and performance appraisal) on turnover intentions.

The selection of this industry as the context of study was based on two main reasons. First, the tourism and hospitality industry is traditionally characterized by high levels of turnover and it is known for having a turnover culture (Davidson and Wang, 2011; Iverson and Deery, 1997). This turnover culture is, to a large extent, a reflection of the labor supply strategies that organizations adopt to cope with a highly seasonal activity (Lai, Soltani and Baum, 2008), but voluntary turnover is also a significant part of the phenomenon. Many employees voluntarily leave the jobs for opportunities outside of the industry (Davidson and Wang, 2011), thus expecting to achieve a more stable and less precarious job situation. The relatively high levels of turnover may represent a significant loss of investment in human capital, training and also customer quality (Davidson, Timo and Wang, 2010). The negative image of jobs in the industry (e.g. precarious, limited career development opportunities, poorly paid, long and alternated working schedules) contributes for many hotels finding the attraction and retention of high quality employees an increasingly difficult task (Hinkin and Tracey, 2000; Davidson and Wang, 2011).

The second reason was that the tourism and hospitality industry is a key driver of employment, not only in Portugal, where this study took place, but also around the globe (World Economic Forum, 2013). It is therefore important to understand the job attitudes and behaviors of those who work in this industry, namely in what concerns their turnover intentions but also other aspects of their relationship with employers. In sum, this industry constitutes a privileged context for analyzing the phenomenon of turnover.

With this study we aim to advance current knowledge about how HRM practices influence hotel employees' intentions to leave the organization by analyzing the potential mediating role of POS. In the next pages, the literature on HRM practices, turnover and POS is revised and the research hypotheses are presented.

2. Literature review

HRM practices allow companies to manage their workforces, as they can be implemented pursuing different aims (Miles and Snow, 1984; Pfeffer, 1994). The recruitment practice, for instance, refers to the way in which the organization operates among potential candidates whose specific skills it needs (Barber, 1998; Gomes and Neves, 2011). On the other hand, the selection practice involves a systematic assessment of potential candidates for a given vacancy, usually carried out by means of tools such as interviews or psychological evaluation tests (Ribeiro, 2002). The training and development practice allows companies to develop the attitudes, behaviors, skills and knowledge of their employees based on a deliberate, planned and systematic learning process (Ceitil, 2002). Performance appraisal can be defined as the deliberate and systematic monitoring of employees' performance at work, including the performance of tasks, objectives and obligations (Fernandes and Caetano, 2002). It is strongly associated with other HRM practices, serving as a provider of information for the attribution of rewards and benefits, for the planning and career management, and also as a measure for evaluating the effectiveness of recruitment and selection and training (Torrington, Hall and Taylor, 2002). Despite being implement for these specific aims, HRM practices can also be implemented for promoting a positive work environment (de Vries, 2001). The effective deployment of HRM practices can help companies to improve business performance and obtain higher levels of customer and employee satisfaction (Becker and Gerhart, 1996).

Regarding employees, and within the framework of social exchange theory, HRM practices send overt and implicit signals about the extent to which they are valued by the organization. Employees' perceptions and interpretations about HRM practices influence how they react to organizations and these reactions are displayed in a variety of emotional, attitudinal and behavioral outcomes (Edgar and Geare, 2005; Purcell and Hutchinson, 2007). Employees' perception of HRM are thus very important and, to some point, even more important than implemented HRM practices because there are predictors of other employee reactions (Guest, 1999; Purcell and Hutchinson, 2007; Whitener, 2001; Wright and Nishii, 2007). Indeed, previous studies found that intended, implemented and perceived HRM practices differ substantially (Khilji and

Wang, 2006; Snape and Redman, 2010). Having this in mind, this study has adopted an employee centered approach and focused its attention on employees' perceptions of HRM practices rather than on intended or implemented HRM strategies, an approach that few studies have adopted until now (Alfes et al., 2013). Similar to the works by Walton (1985) and Khilji and Wang(2006), the focus was on employees' satisfaction with HRM practices.

Employees' reactions can be positive or negative depending on their satisfaction with HRM. For instance, when employees feel they are valued by employers they tend to reveal stronger job satisfaction, organizational commitment, organizational identification and well-being at work (Allen, Shore and Griffeth, 2003; Gonçalves and Neves, 2012; Rhoades and Eisenberger, 2002). The pattern of responses tends to be the opposite when they are displeased with the way their employer manages its workforce and negative reactions such as absenteeism, counterproductive behaviors, turnover intentions and turnover behavior are frequent in this situation (Guchait and Cho, 2010; Huselid, 1995; Karatepe and Vatankhah, 2014).

As mentioned above, turnover refers to the voluntary withdrawal of employee from the organization and constitutes the final stage of a time-based process by which employees create specific physical or psychological remoteness from the organization to which they work (Rosse and Hulin, 1985). The tangible and intangible impacts of turnover have attracted the attention of diverse studies (Griffeth, Hom and Gaertner, 2000), being recognized both the impacts for organizations (e.g. loss of productivity and service quality, costs with recruitment and training of new employees) and for the employees and teams who remain in the workplace (e.g. decrease of motivation, job satisfaction, cohesion and team engagement) (Mobley, 1982; Hinkin and Tracey, 2000). These negative impacts can be particularly relevant for the hotel industry since their competitiveness depends, to a significant extent, on the excellence of their service quality and this cannot be dissociate from the individuals whom provide the services (Hinkin and Tracey, 2000; Singh, 2000; Slåtten, Svensson and Sværi, 2011). Besides the quality lost derived from the actual exit of skilled or experienced employees, literature also reveals that employees with high turnover intentions provide poor service to customers (e.g. Tax and Brown, 1998) and thus impair service quality and productivity.

The withdrawal process includes different but interconnected constructs such as thinking of quitting, intention to search and intention to quit (withdrawal intentions) as well as absenteeism and actual turnover (withdrawal behaviors). Turnover intentions, that is, the conscious will to quit the job and searching for job alternatives in other organizations, has been theoretically and empirically established as a reliable predictor of turnover behavior (Griffeth, Hom and Gaertner, 2000; Mobley, Horner and Hollingsworth, 1978; Mobley, 1982; Steel and Ovalle, 1984). Taking into account the relevance of turnover intentions to actual turnover, this study has analyzed the relationship between employees' satisfaction with HRM practices and their intentions to leave the organization. Based on extant literature we propose the following:

Hypothesis 1 – Employees' satisfaction with HRM practices (career opportunities, compensation, training, and performance appraisal) are negatively related to turnover intentions.

Despite the cumulative literature on the antecedents of turnover, the underlying processes through which HRM practices lead to employees' turnover remain largely unknown (Ertürk, 2014; Zhang and Agarwal, 2009). There are suggestions that HRM practices may be distal determinants of turnover, being their effects mediated by more proximal variables such as job satisfaction, organizational commitment, organizational justice, job embeddedness, leader-member exchange or perceived organizational support (Allen, Shore and Griffeth, 2003; Conway and Monks, 2009; Ertürk, 2014; Griffeth, Hom and Gaertner, 2000; Jørgensen and Becker, 2015; Karatepe, 2013; Loi, Hang-Yue and Foley, 2006; Saorín-Iborra and Sánchez-Manjavacas, 2013; Zhang and Agarwal, 2009).

POS theory has its roots on social exchange theory (Blau, 1964) and emphasizes the importance of supportive organizational practices towards employees and vice-versa. POS involves the degree to which the organization is seen as caring about employees' well-being, providing adequate work conditions and willingness to compensate employees for their contributions (Eisenberger et al., 1986). HRM practices have been considered antecedents of POS because they signal the investment in employees and show recognition of employees' contributions to organizational achievements (Wayne, Shore and Liden, 1997). Although POS may be

linked to particular policies of interest to employees, it may be the overall effect of different HRM practices that is critical for employees' evaluation of companies' commitment to their employees (Purcell and Hutchinson, 2007; Hannah and Iverson, 2004).

POS promotes long term trustworthy relationships between employees and organizations and feelings of obligation to the organization (Shore and Wayne, 1993). Given the existence of a norm of reciprocity (Gouldner, 1960), employees feel the need to pay back the favorable benefits and/or treatment offered by their organizations in the form of positive job attitudes and behaviors. POS is, hence, related to a set of important outcomes such as increased job satisfaction, citizenship behaviors, and organizational commitment (Eisenberger et al., 1997; Eisenberger, Fasolo and Davis-LaMastro, 1990), and lower absenteeism and intention to leave the organization (Allen, Shore and Griffeth, 2003; Ertürk, 2014; Kim, 2014; Loi, Hang-Yue and Foley, 2006; Wayne, Shore and Liden, 1997). Regarding turnover intention, Eisenberger and colleagues (1990) suggested that employees with high POS would be less likely to search and accept jobs in other organizations.

The above mentioned literature suggests that employees' POS constitutes a potential psychosocial mechanism that helps explaining the effect of employees' satisfaction with HRM practices on their intentions to leave the organization. Building on POS theory and social exchange perspective, satisfaction with HRM practices will decrease turnover intentions, by increasing the feelings of being valued and nurtured by the company. These feelings will lead employees to reciprocate the support received from the organization with lower turnover intentions. Therefore, we expect that:

Hypothesis 2 – Perceived organizational support mediates the relationship between satisfaction with HRM practices (career opportunities, compensation, training, and performance appraisal) and turnover intentions.

A description of the study conducted to empirically analyze the model of research is now provided.

3. Method

3.1. Sample and procedure

The present study had a correlational design. Data were collected in a five-star hotel of a major international chain operating in Portugal. All permanent employees (n=211) were invited to participate in the study. Participants completed an individual and confidential survey during working hours in a room provided by the organization. The instructions informed participants that the survey's aim was to better understand employees' opinion regarding social climate and assured response confidentiality and anonymity. For this aim, respondents were instructed to place their surveys in a closed container.

A total of 152 employees voluntarily agreed to participate in the survey (response rate= 72.1%). Most respondents were male (54.9 %), aged between thirty one and forty years old (43.4%) and have completed nine years of schooling or less (59.9%). All participants were employed in a full time basis (100%). Tenure was as follows: five years or less - 32.9%; between six and fifteen years - 38.8%; more than sixteen years - 27.3%. Respondents were from different areas in the organization including front office (22.8%), housekeeping (12.4%), food and beverage (31.5%), and management (8.5%).

3.2. Measures

Data presented in this study were collected as part of an organizational climate survey. Among other measures, the survey included the following ones:

Satisfaction with human resources management practices (predictor variable): Four items adapted from Purcell and Hutchinson (2007) were used to assess employees' satisfaction with career opportunities, compensation, training, and performance appraisal (Table 1; $\alpha=.87$). Respondents expressed their level of satisfaction with each item on a seven-point Likert scale ranging from 1=Very Unsatisfied to 7=Very Satisfied.

Perceived organizational support (mediator variable): Perceived support was assessed using four items adapted from Eisenberger and colleagues (1986) (Table 1; $\alpha=.89$). Respondents expressed their level of agreement with each item on a seven-point Likert scale ranging from 1=Strongly Disagree to 7=Strongly Agree.

Turnover intentions (criterion variable): Two items adapted from Peters, Jackofsky and Salter (1981) were used to measure intentions to leave the organization (Table 1; $r=.48$, $p<.01$). Respondents expressed their level of agreement with each item on a seven-point Likert scale ranging from 1=Strongly Disagree to 7=Strongly Agree. Questions regarding socio-demographic characteristics were also part of the survey (e.g. sex, age, tenure, and educational level).

4. Results

Data was analyzed using structural equation modeling (SEM) techniques (software: AMOS 20), as it allows modeling structural relationships and yielding overall fit indices, while estimating mediational relationships (Hu and Bentler, 1999). Taking into account the size of the sample, SEM analyses were performed using bootstrapping technique ($n=1000$) as it permits a re-sample distribution by calculating “the statistic of interest in multiple re-samples of the data set, and by sampling n units with replacement from the original sample of n units” (Preacher, Rucker and Hayes, 2007: 190).

In terms of analytical procedure, first the goodness-of-fit of the proposed theoretical model was assessed and compared with the goodness-of-fit of a single factor model. Then, the mediation hypothesis was analyzed. All variables entered the analyses as latent variables. For estimating model fit, the Root Mean Square Error of Approximation (RMSEA), Comparative Fit Index (CFI), Tucker-Lewis Index (TLI) and χ^2 values were considered, providing a statistical basis for comparing the relative fit of models. Based on Hu and Bentler (1999) and Marsh, Hau and Wen (2004), models with CFI, TLI values $<.90$, and RMSEA values $>.10$ were considered as deficient. Models with CFI, TLI values $>.90$ to $<.95$, and RMSEA values $<.08$ ranges were considered as acceptable. Models with CFI, TLI values $>.95$ and RMSEA values $\leq.06$ ranges were considered as very good.

Table 1 presents the descriptive statistics and the correlations between all the items used. Overall, respondents’ reported a moderate satisfaction with HRM practices and perceived organizational support and a low turnover intention.

Table 1: Descriptive statistics and correlations

| | M | SD | 1 | 2 | 3 | 4 | 5 | 6 | 7 | 8 | 9 |
|--|------|------|-------|--------|--------|--------|--------|--------|--------|--------|-------|
| 1.HRM1 - Performance appraisal system used by this company | 3.78 | 1.51 | | | | | | | | | |
| 2.HRM2 - Training | 4.16 | 1.57 | .53** | | | | | | | | |
| 3.HRM3 - Extra-salary rewards | 4.05 | 1.59 | .60** | .73** | | | | | | | |
| 4.HRM4 - Promotion system used by this company | 4.47 | 1.66 | .58** | .65** | .63** | | | | | | |
| 5.POS1 - Help is available from the organization when I have a problem | 4.32 | 1.61 | .32** | .30** | .39** | .29** | | | | | |
| 6.POS2 - This organization cares about my general satisfaction at work | 3.87 | 1.65 | .46** | .47** | .53** | .45** | .67** | | | | |
| 7.POS3 - This organization takes pride in my accomplishments at work | 4.22 | 1.51 | .33** | .33** | .44** | .32** | .56** | .70** | | | |
| 8.POS4 - This organization strongly considers my goals and values | 3.85 | 1.61 | .44** | .44** | .54** | .42** | .59** | .78** | .77** | | |
| 9.TI1 - I am actively looking for a new job | 2.56 | 1.87 | -.21* | -.20* | -.29** | -.24** | -.25** | -.41** | -.28** | -.37** | |
| 10.TI2 - Within a year, I hope to be on another job, at another organization | 2.73 | 1.70 | -.13 | -.22** | -.36** | -.21** | -.24** | -.39** | -.28** | -.31** | .48** |

Notes: **p<.01; *p<.05; Source: Authors.

As there were several strong and moderate correlations between the items used as indicators of the latent variables, the goodness-of-fit of proposed theoretical model with the goodness-of-fit of a single factor model were compared. In the theoretical model (Figure 1), a direct path from satisfaction with HRM practices to turnover intentions and POS was specified. A direct path from POS to turnover intentions was also specified.

Figure 1: Theoretical model

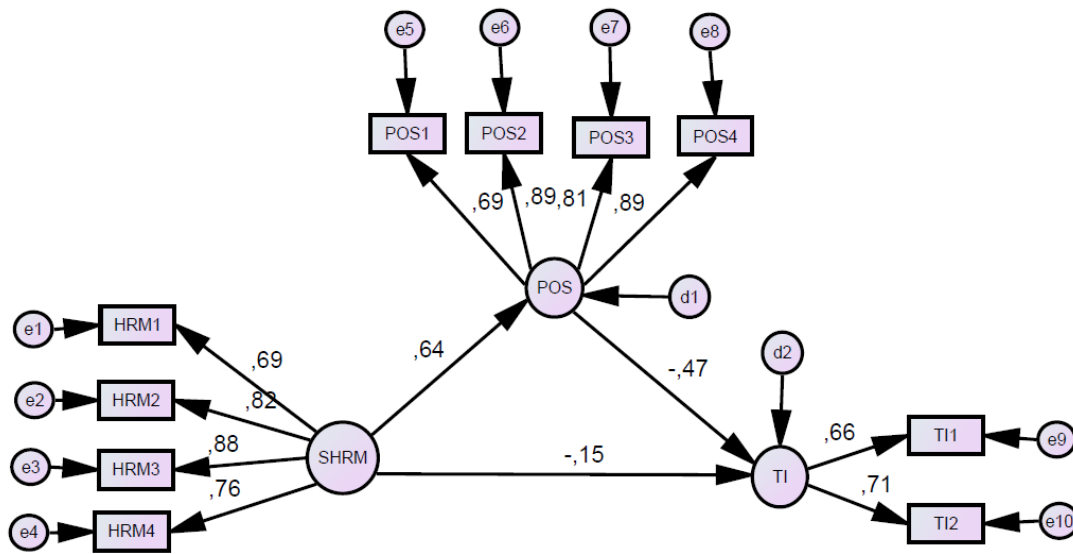

Source: Authors.

The analysis of the goodness-of-fit of the proposed model showed very good fit to the data (Table 2; $\chi^2(33) = 45.40$, n.s.; TLI = .979; CFI = .985; RMSEA = .05). The alternative single factor model has revealed unacceptable fit indices ($\chi^2(35) = 225.12$, $p < .000$; TLI = .695; CFI = .763; RMSEA = .184).

Table 2: Fit indices

| | X2 (gl) | TLI | CFI | RMSEA |
|----------------------|-------------|------|------|-------|
| Single factor model | 225.12 (35) | .695 | .763 | .184 |
| Theoretical model | 45.40 (33) | .979 | .985 | .050 |
| No direct path model | 46.64 (34) | .979 | .984 | .049 |

Source: Authors.

To evaluate mediational effects, the fits of the theoretical model were compared with the ones of an alternative model having no direct path to be estimated. It was found that the proposed theoretical model is slightly better than the alternative model. This evidence suggests a mediational effect of POS in the relation between the satisfaction with HRM practices and turnover intentions.

To observe the magnitude of the mediational effect (if this mediation is either partial or total), the procedures commonly recommended for the analysis of mediation using SEM (Kenny and Judd, 1984) were followed and the direct, indirect and total

effects analyzed. Table 3 evidences the standardized total, indirect and direct effects for the mediational hypothesis validation purposes. The direct effect of satisfaction with HRM practices on turnover intentions is not significant (direct effect =-.15, n.s.). However, the total effect of this predictor on turnover intentions is significant (total effect=-.45; $p < .000$), as well as the indirect effect through perceived organizational support (mediator) (indirect effect=-.30; $p < .000$). These evidences constitute basis for total mediation of POS in the relation between satisfaction with HRM practices and turnover intentions, thus supporting hypotheses 1 and 2.

Table 3: Theoretical model: Total, indirect and direct effects

| | Total effect | Indirect effect | Direct effect |
|---|--------------|-----------------|---------------|
| Satisfaction with HRM practices – Turnover Intentions | -.453*** | -.304*** | -.15 n.s. |

Note: *** $p < .000$.

Source: Authors.

5. Discussion and Conclusions

It is presently recognized that turnover can affect organizational performance (Huselid, 1995) and, consequently, managing turnover continues to be an important matter for organizations (Cascio and Bondreau, 2011; Davidson, Timo and Wang, 2010; Hom, 2011). This is particularly the case for the hospitality industry, characterized by high levels of turnover (Davidson and Wang, 2011; Hinkin and Tracey, 2000; Iverson and Deery, 1997). The investment in supportive management practices is one crucial element to be considered, however few studies have until now analyzed how HRM practices and organizational support can contribute to foster or mitigate employees' turnover. Against this backdrop, this study has examined the mediating effect of POS in predicting hotel employees' turnover intentions from their satisfaction with HRM practices (career opportunities, compensation, training and performance appraisal).

Consistent with previous studies, employees who display higher satisfaction with HRM practices present lower intentions to leave the organization. Employees' evaluation of organization's commitment to workers - based on perceptions of career opportunities, compensation, training and performance appraisal practices - helped to

predict their intention to quit the organization. Other studies have found a similar effect (Allen, Shore and Griffeth, 2003), indicating that HRM practices have an important effect on individual-organization relationship (Edgar and Geare, 2005; Purcell and Hutchinson, 2007). Different to what is usual in hospitality industry, participants reported a relatively low intention to quit the job. This may be due to the fact that all participants were employed at a full-time basis with permanent employment contracts. Literature reveals that part-time employees stay for shorter periods of time in the jobs than full-time employees (Tilly, 1996). Their intentions to leave the organization were, nevertheless, negatively related to their satisfaction with HRM, as predicted in the research model.

Results have also revealed that employees' levels of satisfaction with HRM practices were significantly related to POS. This is consistent with POS theory which proposes that HRM practices can signal employees the degree of organizational concern with and investment in employees (Wayne, Shore and Liden, 1997). The levels of satisfaction with HRM and POS expressed by participants are moderate and were positively related. By considering that the hotel has satisfactory practices in career opportunities, compensation, training and performance appraisal areas, participants seem to derive a positive sense of being adequately supported by their employment organization, as hypothesized.

Moreover, results showed that POS mediates the relationship between satisfaction with HRM and turnover intentions. This means that participants' satisfaction with HRM practices reduces turnover intentions, by increasing perceived organizational support. This is consistent with social exchange theory and the reciprocity norm assumptions (Blau, 1964; Gouldner, 1960), which propose that employees feel the need to repay the favorable treatment offered by their organizations in the form of positive job attitudes and behaviors. Allen, Shore and Griffeth (2003) have found a similar result in a set of studies with salespeople and insurance agents. The perception of supportive HRM practices seems to be crucial for employees' overall well-being at work, reducing the will of looking for another job.

5.1. Theoretical and practical implications

This set of results may have some implication for theory and for practitioners. At a theoretical level, this study contributes to the HRM, POS and turnover literature in a number of ways. Results indicate that HRM practices (career opportunities, compensation, training, and performance appraisal) are one important predictor of POS, being positively related with it. Also satisfaction with HRM significantly predicts turnover intentions, being the relationship between the two variables negative. The higher the satisfaction, the lower the intention to quit. These results replicate previous ones.

More important, the results show that POS mediates the relationship between satisfaction with HRM practices and turnover intention adding to our knowledge on the psychological processes underlying the relationship between the variables. Despite the plethora of theoretical and empirical work about turnover antecedents and consequents, current knowledge of the processes on the basis of these relationships is still limited (Zhang and Agarwal, 2009). This study contributes to overcome this limitation by documenting the mediating role of POS in a sample of hotel employees.

At a practical level, this study has also several implications. The results call our attention to the importance of HRM practices in predicting voluntary turnover. Managers must be aware that HRM practices affect turnover namely by influencing the sense of support received from the organization (Allen, Shore and Griffeth, 2003). The implementation of supportive HRM practices is thus important for employee retention. This applies to several settings, such as the tourism and hospitality here analyzed, where turnover is endemic and skill shortage is prevalent (Davidson and Wang, 2011).

5.2. Limitations and directions for future research

Although this study expands present knowledge about turnover, it has various limitations that should be mentioned. First, the data were collected in a convenience sample. Full-time and permanent employees from a five-star hotel provided the data here analyzed. Therefore, the generalization of findings to other organizations should

be made with caution. Future research needs to obtain more diversified samples to achieve better generalizability. For instance, testing the model with employees with other types of employment contracts and working for other types of lodging organizations. Chow, Haddad and Singh (2007) have shown that the usage of HRM practices varies by hotel type (e.g. resort vs. economy) and this might influence employees' attitudes and behaviors.

Second, the cross-sectional nature of the study does not allow for any conclusions regarding causal relationships. Given that the study had a correlational design the model is recursive and other causal directions between variables can be assumed. The causality amongst variable is theoretically supported in social exchange theory, but future studies can support them empirically by using longitudinal designs.

Third, all variables were collected at the same time from the same source, as part of an organizational climate survey, making the study vulnerable to common method variance (Podsakoff et al., 2003). Although the poor fit of the one-factor model suggests this is not a serious threat to the validity of the study, future studies should preferably collect data at different times.

Fourth, turnover intention, and not actual turnover, was measured in this study. The strong relationship between variables is well-established in the literature (Griffeth, Hom and Gaertner, 2000; Mobley, Horner and Hollingsworth, 1978; Mobley, 1982; Steel and Ovalle, 1984), and therefore it is reasonable to assume turnover intention to be a proxy of turnover behavior. Nonetheless, it would be interesting to study real turnover rate in future studies. Social psychology has shown that intentions and behaviors do not always overlap as many variables can intervene in individuals' daily lives and decisions (Ajzen and Fishbein, 1980).

Fifth, satisfaction with HRM practices was measured based on the evaluation of the degree of satisfaction with only four HRM practices (career opportunities, compensation, training and performance appraisal). The four items revealed a good reliability and were considered an adequate measure to be used in the study. Yet, recognizing that there are other HRM practices (Miles and Snow, 1984; Pfeffer, 1994), and that it is the bundle of HRM practices that affects employees' attitudes and behaviors (Purcell and Hutchinson, 2007; Hannah and Iverson, 2004), it would be

useful to use a more complete measure of HRM practices in future research. The same applies to POS measurement.

Besides overcoming the limitations of the present study, future research can explore other possible mechanism to explain how HRM practices influence turnover. Within the social exchange theory perspective, organizational trust can also be a relevant mediating variable. Another interesting direction for research is the study of moderating variables, such as the level of choice/job alternatives and the job category (e.g. managers and non-managers), since not all employees may assess equally and/or be subjected to the same HRM practices.

5.3. Final remarks

Human resources are the most distinctive and valuable asset of any organization (Cappeli and Crocker-Heftler, 1996) as they provide companies the necessary knowledge, skills and competences to achieve their strategic goals. As they are difficult to imitate they are a key factor for sustainable competitive advantage (Becker and Gerhart, 1996). This is particularly true across industries with lower levels of capital intensity, such as hospitality, where employees play a central role in the functioning of the organization and, consequently, high turnover rates may have considerable negative effects on performance (Datta, Guthrie and Wright, 2005). At the same time, in today's competitive environment, a company's success increasingly depends on its ability to hire high-quality employees and to maximize their contributions to the organization (Chow, Haddad and Singh, 2007). The "war for talent" resulting from the labor shortage in several markets (Michaels, Handfield-Jones and Axelrod, 2001) imposes additional pressure to the management of voluntary turnover. As this study shows, hospitality employees value HRM practices that express organizations' respect, careful and support for their workers. Their desire to stay in the organization is dependent of the perceived organizational support they received from the employer. This is an important finding to be kept in mind by hospitality managers and other HRM practitioners when aiming at preventing the mismanagement of turnover.

References

- AJZEN, I. and FISHBEIN, M. (1980). *Understanding Attitudes and Predicting Social Behavior*. New Jersey: Prentice-Hall.
- ALFES, K., TRUSS, C., SOANE, E.C., REES, C. and GATENBY, M. (2013). The Relationship between Line Manager Behavior, Perceived HRM Practices, and Individual Performance: Examining the Mediating Role of Engagement. *Human Resource Management*, 52(6), 839-859. DOI: 10.1002/hrm.21512
- ALLEN, D.G., SHORE, L.M. and GRIFFETH, R.W. (2003). The Role of Perceived Organizational Support and Supportive Human Resource Practices in the Turnover Process. *Journal of Management*, 29(1), 99-118. Doi: 10.1177/014920630302900107
- BARBER, A.E. (1998). *Recruiting Employees: Individual and Organizational Perspectives*. California: Sage Publications.
- BECKER, B. and GERHART, B. (1996). The Impact of Human Resource Management on Organizational Performance: Progress and Prospects. *Academy of Management Journal*, 39(4), 779-801. Doi: 10.2307/256712
- BLAU, P.M. (1964). *Exchange and Power in Social Life*. New York: Wiley.
- CAPPELI, P. and CROCKER-HEFTER, A. (1996). Distinctive Human Resources are Firms' Core Competencies. *Organizational Dynamics*, 24(3), 7-22. Doi: 10.1016/S0090-2616(96)90002-9
- CASCIO, W.F. and BONDREAU, J.W. (2011). *Investing in People: Financial Impact of Human Resources Initiatives* (2nd Ed.). New Jersey: Pearson.
- CEITIL, M. (2002). Recrutamento e Selecção. In A. Caetano and J. Vala, (Orgs.), *Gestão de Recursos Humanos - Contextos, Processos e Técnicas* (pp. 325-356). Lisboa: RH Editora.
- CHOW, C.W., HADDAD, K. and SINGH, G. (2007). Human Resource Management, Job Satisfaction, Morale, Optimism, and Turnover. *International Journal of Hospitality & Tourism Administration*, 8(2), 73-88. Doi: 10.1300/J149v08n02_04
- CONWAY, E. and MONKS, K. (2009). Unravelling the Complexities of High Commitment: An Employee-Level Analysis. *Human Resource Management Journal*, 19(2), 140-158. Doi: 10.1111/j.1748-8583.2009.00090.x
- DATTA, D.K., GUTHRIE, J.P. and WRIGHT, P.M. (2005). Human Resources Management and Labor Productivity: Does Industry Matter? *Academy of Management Journal*, 48(1), 135-145. Doi: 10.5465/AMJ.2005.15993158
- DAVIDSON, M.C.G. and WANG, Y. (2011). Sustainable Labor Practices? Hotel Human Resource Managers Views on Turnover and Skill Shortages. *Journal of Human Resources in Hospitality & Tourism*, 10(3), 235-253. Doi: 10.1080/15332845.2011.555731
- DAVIDSON, M.C.G., TIMO, N. and WANG, Y. (2010). How Much Does Labour Turnover Cost? A Case Study of Australian Four- and Five-Star Hotels. *International Journal of Contemporary Hospitality Management*, 22(4), 451-466. Doi: 10.1108/09596111011042686
- DE VRIES, M. (2001). Creating Authentizotic Organizations: Well-Functioning Individuals in Vibrant Companies. *Human Relations*, 54(1), 101-111. Doi: 10.1177/0018726701541013
- EDGAR, F. and GEARE, A. (2005). HRM Practice and Employee Attitudes: Different Measures - Different Results. *Personnel Review*, 34(5), 534-549. Doi: 10.1108/00483480510612503
- EISENBERGER, R., CUMMINGS, J., ARMELI, S. and LYNCH, P. (1997). Perceived Organizational Support, Discretionary Treatment, and Job Satisfaction. *Journal of Applied Psychology*, 82(5), 812-820. Doi: 10.1037/0021-9010.82.5.812
- EISENBERGER, R., FASOLO, P. and DAVIS-LAMASTRO, V. (1990). Perceived Organizational Support and Employee Diligence, Commitment, and Innovation. *Journal of Applied Psychology*, 75(1), 51-59. Doi: 10.1037/0021-9010.75.1.51

- EISENBERGER, R., HUNTINGTON, R., HUTCHISON, S. and SOWA, D. (1986). Perceived Organizational Support. *Journal of Applied Psychology*, 71(3), 500-507. Doi: 10.1037/0021-9010.71.3.500
- ERTÜRK, A. (2014). Influences of HR Practices, Social Exchange, and Trust on Turnover Intentions of Public IT Professionals. *Public Personnel Management*, 43(1), 140-175. Doi: 10.1177/0091026013517875
- FERNANDES, A. and CAETANO, A. (2002). A Avaliação do Desempenho. In A. Caetano and J. Vala, (Orgs.), *Gestão de Recursos Humanos - Contextos, Processos e Técnicas* (pp.357-388). Lisboa: RH Editora.
- GOMES, D. and NEVES, J. (2011). Organizational Attractiveness and Prospective Applicants' Intentions to Apply. *Personnel Review*, 40(6), 684-699. Doi: 10.1108/00483481111169634
- GONÇALVES, S.P. and NEVES, J. (2012). The Link between Perceptions of Human Resource Management Practices and Employee Well-Being at Work. *Advances in Psychology Study*, 1(1), 31-39.
- GOULDNER, A.W. (1960). The Norm of Reciprocity: A Preliminary Statement. *American Sociological Review*, 25(2), 161-178.
- GRIFFETH, R.W., HOM, P.W. and GAERTNER, S. (2000). A Meta-Analysis of Antecedents and Correlates of Employee Turnover: Update, Moderator Tests, and Research Implications for the Next Millennium. *Journal of Management*, 26(3), 463-488. Doi: 10.1177/014920630002600305
- GUCHAIT, P. and CHO, S. (2010). The Impact of Human Resource Management Practices on Intention to Leave of Employees in the Service Industry in India: The Mediating Role of Organizational Commitment. *The International Journal of Human Resource Management*, 21(8), 1228-1247. Doi: 10.1080/09585192.2010.483845
- GUEST, D.E. (1999). Human Resource Management - The Workers' Verdict. *Human Resource Management Journal*, 9(3), 5-25. Doi: 10.1111/j.1748-8583.1999.tb00200.x
- HANNAH, D.R. and IVERSON, R.D. (2004). Employment Relationships in Context: Implications for Policy and Practice. In J.A.-M. Coyle-Shapiro, L.M. Shore, M.S. Taylor and L.E. Tetrick (Eds.), *The Employment Relationship: Examining Psychological and Contextual Perspectives* (pp. 332-350). Oxford: Oxford University Press.
- HINKIN, T.R. and TRACEY, J.B. (2000). The Cost of Turnover: Putting a Price on the Learning Curve. *Cornell Administration Quarterly*, 41(3), 14-21. Doi: 10.1177/001088040004100313
- HOM, P.W. (2011). Organizational Exit. In S. Zedeck (Ed.), *APA Handbook of Industrial and Organizational Psychology* (Vol 2, pp. 325-375). Washington, DC: American Psychological Association.
- HOM, P.W. and GRIFFETH, R.W. (1995). *Employee Turnover*. Ohio: South-Western College.
- HU, L.-T. and BENTLER, P.M. (1999). Cutoff Criteria for Fit Indexes in Covariance Structure Analysis: Conventional Criteria versus New Alternatives. *Structural Equation Modeling: A Multidisciplinary Journal*, 6(1), 1-55. Doi: 10.1080/10705519909540118
- HUSELID, M.A. (1995). The Impact of Human Resource Management Practices on Turnover, Productivity, and Corporate Financial Performance. *Academy of Management Journal*, 38(3), 635-672. Doi: 10.2307/256741
- IVERSON, R.D. and DEERY, M. (1997). Turnover Culture in the Hospitality Industry. *Human Resource Management Journal*, 7(4), 71-82. Doi: 10.1111/j.1748-8583.1997.tb00290.x
- JØRGENSEN, F. and BECKER, K. (2015). Balancing Organizational and Professional Commitments in Professional Service Firms: The HR Practices that Matter. *The International Journal of Human Resource Management*, 26(1), 23-41. Doi: 10.1080/09585192.2014.925947
- KARATEPE, O.M. (2013). High-Performance Work Practices, Work Social Support and their Effects on Job Embeddedness and Turnover Intentions. *International Journal of Contemporary Hospitality Management*, 25(6), 903-921. Doi: 10.1108/IJCHM-06-2012-0097

- KARATEPE, O.M. and VATANKHAH, S. (2014). The Effects of High-Performance Work Practices on Perceived Organizational Support and Turnover Intentions: Evidence from the Airline Industry. *Journal of Human Resources in Hospitality & Tourism*, 13(2), 103-119. Doi: 10.1080/15332845.2014.847292
- KENNY, D.A. and JUDD, C.M. (1984). Estimating the Nonlinear and Interactive Effects of Latent Variables. *Psychological Bulletin*, 96(1), 201-210. Doi: 10.1037/0033-2909.96.1.201
- KHILJI, S.E. and WANG, X. (2006). 'Intended' and 'Implemented' HRM: The Missing Linchpin in Strategic Human Resource Management Research. *The International Journal of Human Resource Management*, 17(7), 1171-1189. Doi: 10.1080/09585190600756384
- KIM, N. (2014). Employee Turnover Intention among Newcomers in Travel Industry. *International Journal of Tourism Research*, 16(1), 56-64. Doi: 10.1002/jtr.1898
- LAI, P.-C., SOLTANI, E. and BAUM, T. (2008). Distancing Flexibility in the Hotel Industry: The Role of Employment Agencies as Labour Suppliers. *The International Journal of Human Resource Management*, 19(1), 132–152. Doi: 10.1080/09585190701764048
- LOI, R., HANG-YUE, N. and FOLEY, S. (2006). Linking Employees' Justice Perceptions to Organizational Commitment and Intention to Leave: The Mediating Role of Perceived Organizational Support. *Journal of Occupational and Organizational Psychology*, 79(1), 101-120. Doi: 10.1348/096317905X39657
- MARSH, H.W., HAU, K.-T. and WEN, Z. (2004). In Search of Golden Rules: Comment on Hypothesis Testing Approaches to Setting Cutoff Values for Fit Indexes and Dangers in Overgeneralising Hu & Bentler's (1999) Findings. *Structural Equation Modeling: A Multidisciplinary Journal*, 11(3), 320-341. Doi: 10.1207/s15328007sem1103_2
- MICHAELS, E., HANDFIELD-JONES, H. and AXELROD, B. (2001). *The War for Talent*. Boston: Harvard Business School Press.
- MILES, R.E. and SNOW, C.C. (1984). Designing Strategic Human Resource Systems. *Organizational Dynamics*, 13(1), 36-52. Doi: 10.1016/0090-2616(84)90030-5
- MOBLEY, W.H. (1982). Some Unanswered Questions in Turnover and Withdrawal Research. *Academy of Management Review*, 7(1), 111-116. Doi: 10.5465/AMR.1982.4285493
- MOBLEY, W.H., HORNER, S.O. and HOLLINGSWORTH, A.T. (1978). An Evaluation of Precursors of Hospital Employee Turnover. *Journal of Applied Psychology*, 63(4), 408-414. Doi: 10.1037/0021-9010.63.4.408
- PETERS, L.H., JACKOFSKY, E.F. and SALTER, J.R. (1981). Predicting Turnover: A Comparison of Part-Time and Full-Time Employees. *Journal of Organizational Behavior*, 2(2), 89-98. Doi: 10.1002/job.4030020204
- PFEFFER, J. (1994). *Competitive Advantage through People: Unleashing the Power of the Work Force*. Boston: Harvard University Press.
- PODSAKOFF, P.M., MACKENZIE, S.B., LEE, J.-Y. and PODSAKOFF, N.P. (2003). Common Method Biases in Behavioral Research: A Critical Review of the Literature and Recommended Remedies. *Journal of Applied Psychology*, 88(5), 879-903. Doi: 10.1037/0021-9010.88.5.879
- PREACHER, K.J., RUCKER, D.D. and HAYES, A.F. (2007). Addressing Moderated Mediation Hypotheses: Theory, Methods, and Prescriptions. *Multivariate Behavioral Research*, 42(1), 185-227. Doi: 10.1080/00273170701341316
- PURCELL, J. and HUTCHINSON, S. (2007). Front-Line Managers as Agents in the HRM – Performance Causal Chain: Theory, Analysis, and Evidence. *Human Resource Management Journal*, 17(1), 3–20. Doi: 10.1111/j.1748-8583.2007.00022.x
- RHOADES, L. and EISENBERGER, R. (2002). Perceived Organizational Support: A Review of the Literature. *Journal of Applied Psychology*, 87(4), 698-714. Doi: 10.1037/0021-9010.87.4.698
- RIBEIRO, R. (2002). Recrutamento e Seleção. In A. Caetano and J. Vala, (Orgs.), *Gestão de Recursos Humanos - Contextos, Processos e Técnicas* (pp.267-300). Lisboa: RH Editora

- ROSSE, J.G. and HULIN, C.L. (1985). Adaptation to Work: An Analysis of Employee Health, Withdrawal, and Change. *Organizational Behavior and Human Decision Processes*, 36(3), 324–347. Doi: 10.1016/0749-5978(85)90003-2
- SAORÍN-IBORRA, M.C. and SÁNCHEZ-MANJAVACAS, A.M.S. (2013). La Empleabilidad Interna Percibida como Estrategia Clave del Comportamiento de Ciudadanía Organizativo y la Intención de Abandonar la Empresa. *Tourism & Management Studies*, 9(2), 93-99.
- SHORE, L.M. and WAYNE, S.J. (1993). Commitment and Employee Behaviour: Comparisons of Affective Commitment and Continuance Commitment with Perceived Organizational Support. *Journal of Applied Psychology*, 78(5), 774-780. Doi: <http://dx.doi.org/10.1037/0021-9010.78.5.774>
- SINGH, J. (2000). Performance Productivity and Quality of Frontline Employees in Service Organizations. *Journal of Marketing*, 64(2), 15-34.
- SLÅTTEN, T., SVENSSON, G. and SVÆRI, S. (2011). Service Quality and Turnover Intentions as Perceived by Employees: Antecedents and Consequences. *Personnel Review*, 40(2), 205-221. Doi: 10.1108/004834811111106084
- SNAPE, E. and REDMAN, T. (2010). HRM Practices, Organizational Citizenship Behaviour, and Performance: A Multi-Level Analysis. *Journal of Management Studies*, 47(7), 1219–1247. Doi: 10.1111/j.1467-6486.2009.00911.x
- STEEL, R.P. and OVALLE, N.K. (1984). A Review and Meta-Analysis of Research on the Relationship between Behavioral Intentions and Employee Turnover. *Journal of Applied Psychology*, 69(4), 673–686. Doi: 10.1037/0021-9010.69.4.673
- TAX, S.S. and BROWN, S.W. (1998). Recovering and Learning from Service Failure. *MIT Sloan Management Review*, 4(1), 75-88.
- TILLY, C. (1996). *Half A Job: Bad and Good Part-Time Jobs in a Changing Labor Market*. Philadelphia: Temple University Press.
- TORRINGTON, D., HALL, L. and TAYLOR, S. (2002). *Human Resource Management*. UK: Pearson Education.
- WALTON, R. (1985). Towards a Strategy of Eliciting Employee Commitment Based on Policies of Mutuality. In R.E. Walton and P.R. Lawrence (Eds.) *HRM: Trends and Challenges* (pp. 35-65). Boston: Harvard University Press.
- WAYNE, S.J., SHORE, L.M. and LIDEN, R.C. (1997). Perceived Organizational Support and Leader-Member Exchange: A Social Exchange Perspective. *Academy of Management Journal*, 40(1), 82-111. Doi: 10.2307/257021
- WHITENER, E.M. (2001). Do “High Commitment” Human Resource Practices Affect Employee Commitment? A Cross-Level Analysis using Hierarchical Linear Modeling. *Journal of Management*, 27(5), 515–535. Doi: 10.1177/014920630102700502
- WORLD ECONOMIC FORUM (2013). *The Travel & Tourism Competitiveness Report 2013: Reducing Barriers to Economic Growth and Job Creation*. Geneva: World Economic Forum. Disponível em: http://www3.weforum.org/docs/WEF_TT_Competitiveness_Report_2013.pdf consultado em 07.03.2014.
- WRIGHT, P.M. and NISHII, L.H. (2007). *Strategic HRM and Organizational Behavior: Integrating Multiple Levels of Analysis*. New York: CAHRS at Cornell University.
- ZHANG, H. and AGARWAL, N.C. (2009). The Mediating Roles of Organizational Justice on the Relationships between HR Practices and Workplace Outcomes: An Investigation in China. *The International Journal of Human Resource Management*, 20(3), 676–693. Doi: 10.1080/09585190802707482

ANA PATRÍCIA DUARTE is a Postdoctoral Research Fellow at the Business Research Unit (BRU-IUL) of the Instituto Universitário de Lisboa (ISCTE-IUL) (Portugal). She has a PhD in Social and Organizational Psychology, with a specialization in Organizational Behaviour from ISCTE-IUL. Her research focuses broadly on human resources management, organizational behaviour and corporate social responsibility, and it includes topics such as organizational commitment, job satisfaction, organizational justice, turnover intentions, individual performance and organizational citizenship behaviours. Her research has been published in *Management Research: The Journal of the Iberoamerican Academy of Management*, *Téchne - Review of Applied Management Studies*, *Psicologia* and *Psychologica*. Endereço institucional: Instituto Universitário de Lisboa (ISCTE-IUL), Business Research Unit (BRU-IUL), Av. das Forças Armadas, 1649-026 Lisboa, Portugal.

DANIEL ROQUE GOMES is an Adjunct Professor at Escola Superior de Educação de Coimbra and a researcher at BRU-IUL (Portugal). He has a PhD in Work and Organizational Psychology from ISCTE-IUL. His research focuses broadly on human resources management and includes topics such as recruitment and selection, organizational change, internal communication as also corporate social responsibility. His research has been published in *Management Research: The Journal of the Iberoamerican Academy of Management*, *Business and Management Research*, *Personnel Review*, *Exedra*, *Téchne - Review of Applied Management Studies* and *Revista de Psicología del Trabajo y de las organizaciones*. Endereço institucional: Instituto Politécnico de Coimbra, Escola Superior de Educação de Coimbra, Rua Dom João III – Solum, 3030 Coimbra, Portugal.

JOSÉ GONÇALVES DAS NEVES is an Associate Professor at Instituto Universitário de Lisboa (ISCTE-IUL) and a researcher at BRU-IUL (Portugal). He has a PhD in Social and Organizational Psychology from ISCTE-IUL. His research focuses in industrial and organizational psychology, being climate and organizational culture, HRM, CSR, work and well-being primary research interests. His research has been published in *European Journal of Work and Organizational Psychology*, *Journal of Work and Organizational Psychology*, *Management Research: The Journal of the Iberoamerican Academy of Management*, *Personnel Review*, *Psychology*, *Psicologia: Teoria, Investigação e Prática*, *Revista de Psicologia Militar*, *Revista Portuguesa e Brasileira de Gestão*, *Téchne – Review of Applied Managemnt Studies*, and *Psychologica*. Endereço institucional: Instituto Universitário de Lisboa (ISCTE-IUL), Business Research Unit (BRU-IUL), Av. das Forças Armadas, 1649-026 Lisboa, Portugal.

Submitted: 28 January 2015.

Accepted: 5 April 2015.