

Applied Mathematical Sciences, Vol. 9, 2015, no. 26, 1273 - 1280
HIKARI Ltd, www.m-hikari.com
<http://dx.doi.org/10.12988/ams.2015.5110>

Why a New Representation Model for Games:

The Code Form

M. C. P. Matos¹

Instituto Politécnico de Viseu (IPV), ESTV, Viseu, Portugal

M. A. M. Ferreira

Instituto Universitário de Lisboa (ISCTE – IUL), BRU – IUL
Lisboa, Portugal

Copyright © 2015 M. C. P. Matos and M. A. M. Ferreira. This is an open access article distributed under the Creative Commons Attribution License, which permits unrestricted use, distribution, and reproduction in any medium, provided the original work is properly cited.

Abstract

The aim of this work is to present a representation model of games which will establish the characteristics of each game with complete rigour. This model is presented emphasizing applications of theory, as much or more than the theory itself due to thinking, on the one hand, that applications help understand theory, and on the other, that applications illustrate the process of model building. Thus, this model is intended to illustrate the full rigour games both in terms of information, and in terms of real time structure of the games.

Keywords: Game theory, strategic form game, extensive form game, code form game theorem

1 Introduction

Many and interesting interactions in life can be translated into games, but games can be played in various ways not all of which lead to the best result. Therefore, understanding the interactions is fundamental to developing knowledge about how they work making modelling such situations exceptional. The usual representation models suppress much of the game information, including temporal information and structural complexity, which may be misleading when analysing

¹Corresponding author

a game. For this reason we have developed a model representation of model games which centres the consequences of different strategies without suppressing the meticulousness of the other game representations.

In order to demonstrate the purpose we set out to exemplify the three representation models of a game. We start by introducing and analysing the new model and then applying currently existing models to the same example.

2 Myerson's Card Game

First, let us begin by presenting a card game by Roger Myerson:

Suppose there are two players, labelled "player 1" and "player 2". At the beginning of this game, each player puts a dollar in a pot. Next, player 1 draws a card from a shuffled deck of cards in which half the cards are red and half are black. Player 1 looks at his card privately and decides whether to raise or fold. If player 1 folds, then he shows his card to player 2 and the game ends; player 1 takes the money in the pot if the card is red, but player 2 takes the money if the card is black. If player 1 raises, then he adds another dollar to the pot and player 2 must decide whether to call or pass. If he passes, the game ends and player 1 takes all the money in the pot. If he calls, he puts another dollar in the pot, and then player 1 shows his card to player 2 and the game ends; if the card is red, player 1 takes all the money in the pot, but if it is black, player 2 takes all the money.

a. Code Form

A player, who is admittedly rational, is a participant in a game and aims to make decisions producing preferred outcomes or probability distributions when the game presents uncertainty about preferred outcomes. When there is uncertainty, the player's preferences are described by utility functions and decisions are made to maximize expected utilities.

A coded representation of a game consists of a table that encodes all the information of a game. To prevent the representation from becoming difficult to read and interpret, the cells are only filled when the information they contain is not repeated. The first column in the model indicates number of the move. The following columns, except for the last, which meaning we will see further below, contain the information associated with different moves: the player deciding at that point, which decisions are available to the player, and which decision is taken and the probability that it may occur. Each line represents a different action for each move.

Our example begins with uncertainty, in that the first move is random. This move is represented by a dummy player we call *Nature* – *N*. As we can see the player makes no decisions; his actions are purely mechanical and probabilistic and determine the probability distribution over random moves. Let us consider our example, Nature "chooses" the colour of the card which 1 player randomly draws from the pack. Player *N*'s two possible "actions" are "*Black*" or "*Red*". Since the number of red cards is equal to the number of black cards and the pack is shuffled, the probability of a red or black card being drawn randomly is $\frac{1}{2}$; that is, the prob-

ability that each one occurs is $\frac{1}{2}$. Each available action leads to a decision point where player 1 has to make a choice between continuing and finishing the game. When it is player 1's turn to play, he knows the colour of the letter he withdrew from the pack and decides to "Raise" – I or "Show" – F depending on the colour of the card in his hand. His decision is conditioned by the colour of the card. In both cases, his choices are between increasing the bet or showing his hand so that his information sets are $I_{\text{Black}} = \{I, F\}$ and $I_{\text{Red}} = \{i, f\}$. Although his actions are the same, different codes are used to highlight that they occur in different contexts. "F" means showing the game if he has drawn a black letter and "f" means showing the game if has drawn a red card.

A game consists of endgames, where each story of the game is a sequence of actions taken by various players in their information sets. For example (Black) is the endgame which means that *Nature* has chosen the colour black, while (Black,F) means that *Nature* chose the colour black and player 1 chose to show the card. The set of all *final endgames* coincides with the set of results when the game is played. For example, (Red, f) is an endgame because the game concludes if one player shows his hand. Conversely, (Red) and (Red,i) are not endgames because the game proceeds. Now, for each player a *payoff* function is specified which associates the set of final stories, or results, with real numbers. Of course, this function should represent the player's order of preference as for the different results. As (B, F) and (R,f) are both endgames, the player's *payoff* functions attribute numbers to these results. Assuming that utilities are linear functions regarding the amount of money received, i.e., $u(z) = z$, then:

$$u_1(\text{Black},I)=u_2(\text{Red},i)=-1 \text{ e } u_2(\text{Black},I)=u_1(\text{Red},i)=1.$$

The payoffs are listed in the last column of the table, which is code form. Each payoff is placed on the line that is the endgame associated with each possible story of the game. The order of the payoffs is determined by the sequence in which players appear in the game, from top to bottom and from left to right. In our

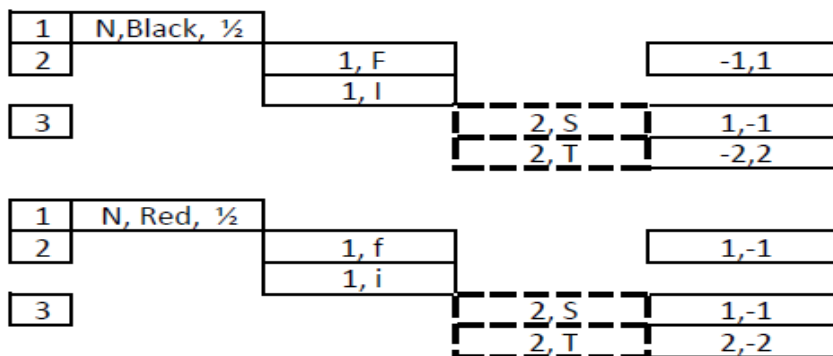

Fig 1. Myerson Card Game – Code Form

example, the first number is player 1's payoff and the second number is player 2's payoff. If player 1 increases his raises, player 2 must make a move. Thus, as many rows as player 2 has possible moves are added and the corresponding cells filled with player 2's code to indicate that he is the one taking decisions in that move. At this stage of the game, player 2 can "pass" – S or "raise" – T. Figure 1 shows our example in code form.

The crucial difference between the information available to player 1 and player 2 is that player 2, unlike player 1 does not know the colour of card 1 player, despite knowing his move. In other words, when player 2 must act, he does not know if player 1's card is red or black. Player 2's information set thus includes both possible endgames (Black,I) and (Red,i). Since each of these endgames leads to a different decision point for player 2, the corresponding cells are outlined with dashed lines to show that those endgames belong to the same information set. The information set represents the fact that when it is the player 2's turn to play, he does not know the colour of the card; he only knows what he can see: that player 1 chose to raise.

The rigour of of a game's code form is guaranteed both in the number of moves, as well as in the information inherent in the table's different cells. There is no room for ambiguity and the model corresponds to a reliable conceptualization of the situation to be analysed.

b. Strategic Form

The strategic or normal form that represents a game through a payoff matrix focuses game analysis on the players' strategies. It completely disregards the dynamics of the moves associated with the game and so much of the game information is lost. The idea is that each player chooses his action once and for all, and players choose their actions simultaneously, in the sense that no player is informed when choosing their action or when the action chosen by any other player. The fact that time is missing from the model means that when analysing a situation as a strategic game, one removes oneself from the complications that can arise when a player changes his plan of action. Sometimes the information which is ignored is not relevant to the conclusions derived from the game, other times the omission of information can be disastrous. Strategic form does not distinguish random and sequential moves from simultaneous moves.

Considering the strategic form is a static model in that it completely disregards the dynamics of movements associated with a game, it is necessary to make some adjustments so as to overcome the timing of moves. This is done by first identifying the different players' pure strategies. Then, the expected outcomes of all the strategic profiles are constructed and finally the utility functions in the results are redefined turning them into utility functions in the profiles with expected outcomes.

In our example, player 1 has two information sets. His strategy should be written as an ordered set in which the first element designates the action to be taken in one of the information sets and the second designates the action to be

taken in another information set. This yields four pure strategies for player 1: $S_1 = \{Ii, If, Fi, Ff\}$. Player 2, on the other hand, will only play if player 1 decides to raise, so that player 2's pure strategies are $S_2 = \{T, S\}$. Therefore, the strategy profiles are:

$$S = S_1 \times S_2 \{ (Ii, T), (Ii, S), (If, T), (If, S), (Fi, T), (Fi, S), (Ff, T), (Ff, S) \}.$$

Previously the utility functions were defined based directly on the outcome; now the expected utility functions have to be defined for the player since the real outcome of the game will depend on the colour of the card, which is a random choice. For example, if player 1 chooses the Fi strategy and player 2 chooses T , the strategic profile is (Fi, T) . The outcome for player 1 will be to show if the card is black; to raise for player 1 and raise for player 2 if the card is red. Player 1's payoff is -1 if the card is black and 2 if the card is red.

The payoff that player 1 should expect from each strategy profile is his expected payoff. In the particular case of the (Fi, T) profile, choosing the Fi strategy on the chance that player 2 chooses T is equivalent to choosing a raffle in which player 1 would receive -1 with probability $\frac{1}{2}$ and with probability $2 \frac{1}{2}$. Thus, the expected payoff for player 1 is given by:

$$u_1(Fi, T) = \frac{1}{2} * u_1(\text{Black}, I) + \frac{1}{2} * u_1(\text{Red}, i, T) = \frac{1}{2} * (-1) + \frac{1}{2} (2) = \frac{1}{2}.$$

For player 2, the expected payoff is given by:

$$u_2(Fi, T) = \frac{1}{2} * u_2(\text{Black}, I) + \frac{1}{2} * u_2(\text{Red}, i, T) = \frac{1}{2} * (1) + \frac{1}{2} (-2) = -\frac{1}{2}.$$

Similarly, the expected payoffs are calculated for both players in all of the strategic profiles. The strategic form representation of this game of uncertainty is shown in Figure 2.

	T	S
Ii	0, 0	1, -1
If	$-\frac{1}{2}, \frac{1}{2}$	1, -1
Fi	$\frac{1}{2}, -\frac{1}{2}$	0, 0
Ff	0, 0	0, 0

Fig 2. Myerson Card Game – Strategic Form

c. Extensive Form

Extensive form presents a great amount of detail of the games, where the structure closely follows the rules of the game. This model allows the time structure to be made explicit as well as the game's data structure to be defined as players' previous decisions may not be immediately observable by their opponents. Each player can consider his plan of action not only at the beginning

of the game, but also when he has to make a decision. In the extensive form of a game, some moves may be random, such as tossing a die. The rules of the game specify the probability of the outcome when random moves occur. We can also talk about the information that players have when it is their turn to play.

The structure of the extensive form is a game tree and given the formalism of the tree, we are required to represent the choices sequentially. So that equivalence between sequential and non-sequential representation of the game may exist, relevant information of the structure of a game of simultaneous moves is extracted and they are represent in the extensive form. Representing a player's choice before or after another player's choice can be arbitrary in this model, so that there may be multiple representations for the same game. We can easily reverse the players' roles.

Figure 3 is a representation of the extensive form of our example. The dotted line means that player 1's first move is not observed by player 2.

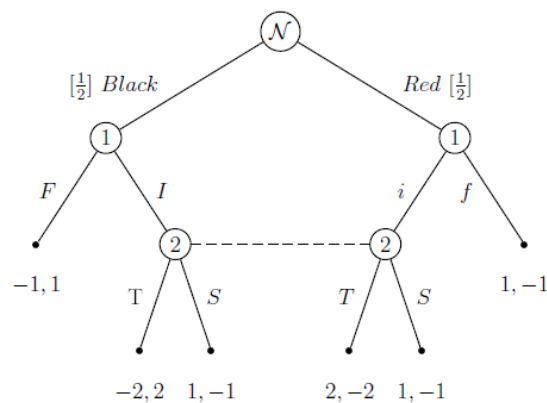

Fig. 3. Myerson Card Game – Extensive Form

3 Conclusions

As we can see, the model which supports extensive form of a game allows this example to be represented in two distinct ways. For us this is a major drawback from the outset since one of them does not match the description of the game as it is presented. It is a fact that both representations are congruent with the example under analysis, but in fact, the latter distorts what is actually going on with this game. Placing two individuals, each looking at one of these two representations, and asking them for a verbal description of the game behind it will surely yield different replies.

Let us imagine a game in which two players act simultaneously on the first move and that a third player comes into play simultaneously with these two players on the second move (a company that starts up). How could this situation be represented by extensive form so as to safeguard all information accurately?

Moreover, a disadvantage of the strategic form representation of the game that can be found immediately with this example is the inability of this model to represent the game as it is presented to us. Because it focuses on players' actions, strategic form cannot represent random moves. For this reason there must be a code form or extensive form prior to the game so as to then convert the game to strategic form with the appropriate equivalences. This implies that the information about the timing of the moves explicitly specified in code form will be ignored.

From our point of view our objective has been completely achieved. The model we have developed is, in fact, based on three basic principles that we believe are fundamental to anyone, with or without mathematical knowledge, to understanding the model and hence the representation of a game. We also believe that this form of representation allows the games to be analysed more expeditiously and consistently, allowing then to extrapolate conclusions to situations that occur in many strategically interdependent situations.

References

- [1] Fudenberg, D., Tirole, J., "Game Theory", MIT Press, 1991.
- [2] G. Asheim, M. Dufwenberg, "Deductive reasoning in extensive games," Stockholm University, Department of Economics in its series Research, Papers in Economics, n° 2000:7, 2000.
- [3] J. von Neumann, O. Morgenstern, "Theory of games and economic behavior", Princeton University Press, Princeton, New Jersey, 1947.
- [4] M. A. M. Ferreira, M. Andrade, "Management optimization problems", International Journal of Academic Research, Vol. 3 (2, Part III), 647-654, 2011.
- [5] M. A. M. Ferreira, M. Andrade, M. C. Matos, J. A. Filipe, M. Coelho, "Minimax theorem and Nash equilibrium", International Journal of Latest Trends in Finance & Economic Sciences, 2(1), 36-40, 2012.
- [6] M. A. M. Ferreira, M. C. P. Matos, "Convex sets strict separation in the minimax theorem", Applied Mathematical Sciences, 8 (36), 1781-1787, 2014.
<http://dx.doi.org/10.12988/ams.2014.4271>
- [7] M. A. M. Ferreira, J. A. Filipe, "Convex sets strict separation in Hilbert spaces", Applied Mathematical Sciences, 8 (64), 3155-3160, 2014.
<http://dx.doi.org/10.12988/ams.2014.44257>
- [8] M. C. Matos, M. A. M. Ferreira, "Game representation -Code form", Lecture Notes in Economics and Mathematical Systems, 567, 321-334, 2006.
http://dx.doi.org/10.1007/3-540-28727-2_22

[9] M. C. Matos, M. A. M. Ferreira, M. Andrade, ‘ Code form game’’, *International Journal of Academic Research*, 2(1), 135-141, 2010.

[10] M. C. Matos, M. A. M. Ferreira, J. A. Filipe, M. Coelho (2010). “Prisoner`s dilemma: cooperation or treason?”, *PJQM-Portuguese Journal of Quantitative Methods*, 1(1), 43-52, 2010.

[11] R. Gardner, “Juegos para empresarios e economistas”, Spanish translation by Paloma Calvo and Xavier Vilà; Antoni Bosch, Editor, S. A.; Barcelona, March 1996 .

[12] Several Authors, “Handbook of Game Theory with Economic Applications”, Editors: Aumann R. J. and Hart S., Vol 1, II, III, North-Holland, 1999.

Received: January 16, 2015; Published: February 19, 2015