

A GENERAL APPROACH FOR SECURITY MONITORING AND PREVENTIVE CONTROL OF NETWORKS WITH LARGE WIND POWER PRODUCTION

Helena Vasconcelos
INESC Porto
hvasconcelos@inescporto.pt

J. N. Fidalgo
INESC Porto and FEUP
jfidalgo@inescporto.pt

J. A. Peças Lopes
INESC Porto and FEUP
jplopes@inescporto.pt

INESC Porto – Instituto de Engenharia de Sistemas e Computadores do Porto
FEUP – Faculty of Engineering of the University of Porto
Porto, Portugal

Abstract – This paper provides a description of the development of software tools able to deal with system fast dynamic monitoring and determination of preventive control procedures, for a given set of disturbances, in networks with large integration of wind power production. Preventive control is performed through power redispatches, involving also the on/off control of the wind generators. The quality of the approach is illustrated here through its application to the system of the Madeira island.

Keywords: security assessment, preventive control, artificial neural networks, data set generation, frequency dynamic behavior, wind power

1 INTRODUCTION

Dynamic security became nowadays a key issue in the definition of the operation strategy of any power system due to the stressed conditions that the network has to face in the present liberalized scenarios. At the same time, there is an enormous pressure to increase the integration of renewable power production in the systems, which makes dynamic security assessment more and more a crucial aspect in the definition of the operating policy to be followed. The dynamic behavior problems that may appear in the system result, in part, from the intermittent nature of some of the renewable energy sources and from its non-complete controllability. Specifically in the case of large wind power integration the problem can turn on quite critical, due to large frequency deviations that may appear.

In order to deal with this issue, control centers should be able to assess, in an efficient way, dynamic security for the present and future operating conditions and, in this way, define a secure and robust operating policy. This may be achieved through the solution of the unit commitment with dynamic security restrictions regarding forecasts of load and renewable power production. It may happen, however, that the system follows a different trajectory or be subjected to changing conditions relatively to the foreseen ones, such that a given operating point may become dynamically insecure regarding to a given disturbance. In this case, preventive control measures may be suggested to the system operator, in the form of a redispatch solution.

This control philosophy is being developed within the framework of an EU R&D project that aims to develop an advanced control system for large isolated networks with high penetration of renewable sources [1]. In this control system, operators receive suggestions about the operating strategy to be followed in order to run the system in the most economic and secure way. The part of the on going research to be described in this paper addressed the following issues:

- System dynamic monitoring, which for the power systems under consideration regards to frequency stability problems;
- Definition of preventive control measures that are able to drive the system into a secure region of operation.

Here, the dynamic security of the system is assessed regarding to a set of pre-defined disturbances. The development of these procedures involves three main stages:

- Development of a specially oriented data set generation procedure;
- Design of a fast dynamic security assessment tool, through the determination of an automatic learning structure (an artificial neural network in this case);
- Development of a preventive control tool.

The development of efficient dynamic security assessment tools for isolated systems with large integration of wind power production has been a matter of research during the last years [2][3]. However the increase in dimension and complexity of the systems under study demanded that a special care should be put in the Data Set Generation stage, in order to gather a representative knowledge about the system dynamic behavior and therefore be able to design robust security assessment tools. This is one of the innovative contributions of this paper. At the same time, the interest in defining preventive control measures lead us to the development of an innovative approach through which it is possible to determine new feasible generation set points, exploiting the sensitivities of the ANN output with respect to the inputs. This control tool is based on the Projected Gradient technique [4], where the functions to be dealt with are the ANNs used for security assessment. This control tool is supposed to be used by the operator when insecurity is detected for a

given disturbance. The new generation set points, obtained in this way, correspond to a new redispatch, where security is then assured for the critical disturbances selected by the operator.

The quality of the developed procedures is illustrated here through its application to the power system of the Portuguese island of Madeira, where a pilot installation of the advanced control system is going to be implemented during the year 2002. This system is an isolated grid with thermal, hydro, waste to energy and wind power production, with a peak load of 120 MW. In this system, three disturbances were considered to be crucial for dynamic security evaluation purposes (two short circuits followed by the disconnection of some plants, sudden disconnection of the largest generator in operation).

2 DATA SET GENERATION

Security assessment techniques based on automatic learning usually demand a data set (DS) enclosing representative knowledge. An overview of a general procedure to apply automatic learning to security assessment of power systems can be found in [5].

In the research presented in this paper, a general DS generation methodology was developed, in order to gather knowledge about the frequency dynamic behavior of power systems regarding to a pre-defined disturbance. In this procedure, a structured Monte Carlo sampling method [6] was applied, because it provides a well distributed and highly resolved DS throughout the defined operating range. The following operating conditions were considered to generate diversity in the DS: total active load (*Pload*); active generation in each non-dispatchable production (*Pnd*), which regards non-controllable or partially controllable machines (like wind and independent units) or machines with hard dispatch restrictions; scheduling and dispatch solution for the remaining generators.

These conditions were defined regarding their potential influence on the frequency dynamic behavior to evaluate.

After the definition of each DS operating scenario, a power flow needs to be solved to check the feasibility of the network steady-state operating conditions, and also to define the system initial conditions before disturbances. The frequency dynamic behavior to each disturbance is then provided by the numerical integration of the system state equations.

The dimension and complexity of the systems under analysis, and namely the high penetration of wind and the presence of independent power plants, demanded the inclusion of several operating restrictions, which led to the development of a specially oriented data set generation procedure. Including these restrictions was crucial to filter out unrealistic scenarios, and therefore to decrease computational time without compromising the knowledge data quality. Besides, this also avoids power flow convergence problems, in face of unfeasible conditions.

2.1 Automatic Generating Procedure

The automatic procedure developed to generate the DS is presented in Figure 1 and consists of the following steps:

1. Construction of Hypercells

The DS operating range is previously defined and divided into *hypercells*. This procedure is performed according to the range and resolution assigned for the independent operating conditions to change, namely *Pload* and the *Pnd* productions.

2. Structured Monte Carlo Sampling

For each *hypercell*, the *Pload* and all *Pnd* variables are randomly sampled. In this procedure, besides the active generation sampling, the on/off status of the machines may also be sampled with a pre-defined probability. These two operating conditions may still be directly defined.

Additionally, dispatch dependencies may also be included. In these cases, the load level of some unit α is defined to depend from another unit β in the following way:

$$Pnd_{\alpha}(MW) = \frac{Pnd_{\beta}(MW)}{Pn_{\beta}(MW)} \times Pn_{\alpha}(MW) \times RN \quad (1)$$

where: Pn is the unit nominal value, and RN is a real number in $[0,1]$. RN is pre-defined, or it may be sampled inside a defined range in order to introduce diversity to the relationship.

For wind generators, a set of units may be associated to a given wind area. In this case, the sampled variable passes to be the load level of the wind area (*Pwa*). For instance, considering that unit α is associated to wind area *wa*, the load level of unit α is given by:

$$Pnd_{\alpha}(MW) = \frac{Pwa(\%)}{100} \times Pn_{\alpha}(MW) \times RN \quad (2)$$

To avoid that the total sampled *Pnd* exceeds the required non-dispatchable power production, for each *Pload/Pnd* sampled scenario, a simple procedure is applied to remove power production surplus from *Pnd*, assuring that $Pload \geq Pnd + Pgmin$, where $Pgmin$ is the minimum value defined for the dispatchable power production.

3. Units Scheduling

For each *Pload/Pnd* scenario, a scheduling module considers all feasible scheduling combination of the dispatchable units, taking into account: maximum and minimum acceptable production limits of each unit and a spinning reserve criterion.

4. Dispatch

For each *feasible units scheduling scheme*, a dispatch module randomly distributes the insufficiency of power production by the units that were defined to be in operation by the scheduling module, considering again their production limits. Then, all the obtained dispatch solutions are ordered according to their increasing production cost. From this set, only the n first solutions are selected.

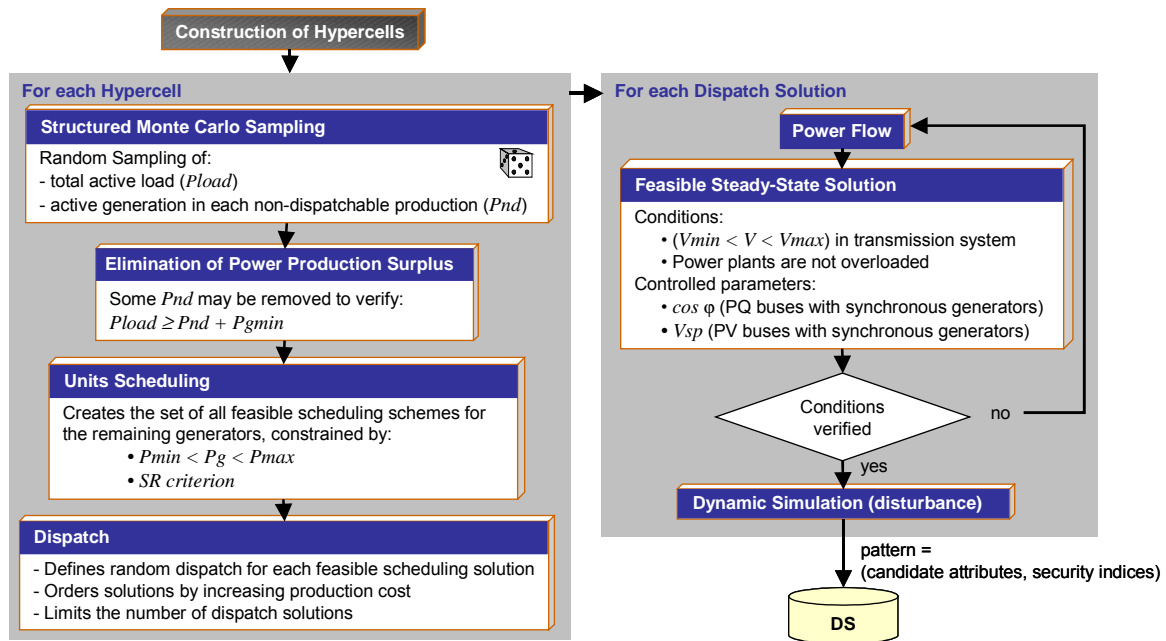

Figure 1 : Data Set generating flowchart

5. Power Flow

For each *selected dispatch solution*, the steady-state operating conditions are obtained through a power flow calculation. However, before power flow, there is an interface module that takes care of: distribution of total active load by the active and reactive loads of the transmission system; power factor specification for PQ synchronous generators, voltage specification for PV synchronous generators; and Mvar value for the local capacitor bank of asynchronous generators taking into account their production level.

6. Feasible Steady-State Solution

Before starting the dynamic simulation, the feasibility of the power flow solution is checked regarding the following operating restrictions:

- min and max allowed voltage values in the transmission system;
- MVA capacity of the synchronous generators;

by acting on the following parameters:

- power factor in PQ synchronous generators;
- voltage in PV synchronous generators.

7. Dynamic Simulation

For each accepted steady-state solution and considered disturbance, a dynamic simulation analysis is performed in order to get the dynamic security indices. Namely, regarding the security problem under analysis for the study system, the considered security index was the maximum value reached by negative frequency deviations Δf (due to relay settings of the load shedding frequency protection devices).

After each dynamic simulation analysis, a pattern is added to the DS, being characterized by the set of candidate attributes and the security index.

2.2 Data Set Requirements for Security Monitoring and Preventive Control

The quality of the security information contained in the DS is a critical issue of the security assessment process. If this data is biased, unrepresentative or too small, then the information extracted by the automatic learning security structures will probably be useless [5]. A high quality data must cover all possible states of the power system, and with the best possible resolution. Specially, a good resolution must be obtained in the neighboring of the security boundary, in order to reach good accuracy for those operating conditions.

Regarding this, in order to assess the effect of countermeasures suggested by the control center to be installed, when defining the DS settings for the study case, non-conservative dispatch policies were necessary to be established (like considering a lower setpoint for the minimum acceptable spinning reserve value). In order to obtain satisfactory security information, and namely a good resolution in the neighborhood of the system security boundary, a different DS was generated for each considered disturbance, where the following stages were considered:

1. A preliminary DS was generated.
2. A data analysis was performed in order to identify the sampling settings that lead to: operating point (OP) which dynamic behavior is not sufficiently well represented, OP near the security boundary;
3. Some more patterns were generated, based on these last extracted sampling settings.

3 DESIGN OF THE SECURITY ASSESSMENT STRUCTURES

The design of the security assessment structures involved two main interactive stages: attributes selection and ANN training.

3.1 Attributes Selection

In order to perform preventive control, the set of attributes chosen to represent system state should have the following characteristics:

- To perform accurately, *i.e.*, to provide a small error in the assessment of security index, for all OP considered in the data set;
- The number of attributes should be as low as possible without losing relevant information. In this research, the concept of “equivalent machine” was used to group similar generators operating in parallel in the same plant;
- System control variables, namely dispatch variables, should be selected as potential candidates;
- Controllable variables should be independent or, at least, its relation should be “clear-cut” in order to simplify control algorithm. This requirement will be explained later in this paper.

Simulations performed in some systems had shown that security assessment performance was improved when some dependent variables (like P – power produced - and SR – spinning reserve) were chosen as system attributes.

3.2 Artificial Neural Networks

In this research, an ANN based tool was chosen, since it performs generally better than concurrent tools in the fast dynamic security classification of power systems [2][4]. Besides, they provide the evaluation of the system security degree. Moreover, they offer simple and effective mechanisms of computing the derivatives of a security index with respect to the input variables, which allows the application of gradient based methods for control purposes.

Before starting the training stage, training patterns were normalized to have zero mean and a standard deviation of one. This removes offset and measurement scale problems. ANN parameters were found through the Adaptive Backpropagation (ABP) training algorithm [7]. The ABP is based in the traditional Backpropagation [8][9], but instead of a fixed and unique learning rate it uses an individual adaptive learning rate for each weight, which provides a much faster learning process. The stop training criterion adopted was based on the *cross validation principle* [9].

4 PREVENTIVE CONTROL ALGORITHM

In the advanced control system, a security monitoring for the selected disturbances is performed continuously, which means that each trained ANN (one for each considered disturbance) will be continuously fed with system attributes and will output the expected negative

frequency deviation Δf for each case. In this control center, the main goal of the preventive control algorithm (PrevC) consists of presenting to the system operator an alternative secure dispatch solution after a potential insecure state. In this way, PrevC will search a new feasible OP on the generators under operation, without considering other non-wind Unit Commitment alternatives. For wind power plants, the connection and disconnection of generators was also considered. Having in mind that the power system may have several independent producers, the search is constrained, in a first approach, to the utility generators. Although there are some agreements between utility and independent producers in what respect system control in case of insecurity, in this study the generators belonging to independent producers were considered as “non-controllable” – the most restrictive situation.

In [2][4], authors experienced similar approaches. However, in these studies, all system generators were considered as controllable, which lead to a spacious searching domain. Another limitation of the methodologies proposed in [2][4] concerns the ANN inputs: a quality characterization of system security state had to be made by independent variables. This limitation may be restrictive in some cases where security characterization (Δf) is more accurately computed when ANN inputs may be selected on the base of its discriminative capability.

4.1 Mathematical Formulation

The actual problem may be summarized as follows: given an insecure dispatch solution, an exchange power among generators is performed in order to move system towards security. For that purpose, a gradient based iterative procedure was implemented, where each step is given towards security domain. Gradient directions are based on ANN sensitivity coefficients considering, at the same time, dependencies among ANN inputs. This innovative aspect discriminates the adopted approach from other techniques reported in literature.

The problem formulation may be settled as follows:

$$\max \Delta f(Pc_i, SR_i, Nw_j, Pw_j) \quad (3)$$

$$\text{Subj.} \quad \sum_i Pc_i + \sum_j Pw_j = P_{load} \quad (4)$$

$$Pc_i^{min} \leq Pc_i \leq Pc_i^{max} \quad (5)$$

$$SR_i = Pc_i^{max} - Pc_i \quad (6)$$

$$Nw_j \in \{0, 1, \dots, N_j\} \quad (7)$$

$$Pw_j = Nw_j Pw_j^{ind} \quad (8)$$

where:

P_{load} – total active load;

$Pc_i, SR_i, Pc_i^{min}, Pc_i^{max}$ – active power produced, spinning reserve, minimum and maximum technical limits of equivalent “non-wind” generator i ;

Nw_j, N_j – number of operating units and number of total available units in equivalent wind generator j ;

Pw_j, Pw_j^{ind} - power produced by equivalent wind generator j and power produced by each individual unit of this cluster.

Each iteration consists of a small change in the generation power of each equivalent machine, following gradient direction in order to increase Δf . Gradient components are computed as described in [4], using ANN capabilities. The optimization process described by equation (3) would be much simpler if constraints (4-8) were not considered. Note, for instance, that if an ANN input Pc_i may be changed without considering the other ones, one would simply increase Pc_i if $\partial \Delta f / \partial Pc_i > 0$, and decrease Pc_i if $\partial \Delta f / \partial Pc_i < 0$. However, when Pc_i is increased, the spinning reserve SR_i should be decreased in the same amount. So, one should only increase Pc_i if $\left(\frac{\partial \Delta f}{\partial Pc_i} - \frac{\partial \Delta f}{\partial SR_i} \right) > 0$.

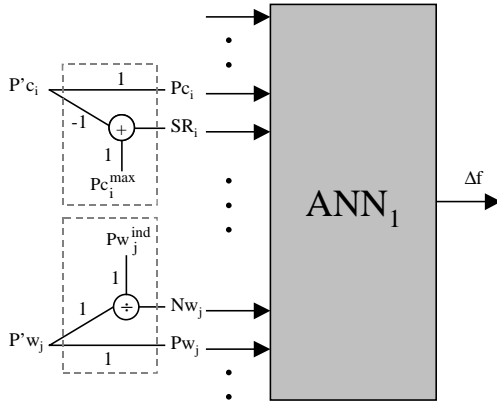

Figure 2 : ANN based interpretation of variables sensitivities dependences.

Figure 2 shows another interpretation of this conclusion. Let us consider the virtual variable $P'c_i$ instead of Pc_i and SR_i . One may even imagine a very simple ANN (dash line) to perform this task. Following the unitary weights shown near each synapse, it's easy to confirm that:

$$Pc_i = P'c_i \quad (9)$$

$$SR_i = Pc_i^{max} - P'c_i \quad (10)$$

So, using the chain rule,

$$\frac{\partial \Delta f}{\partial P'c_i} = \frac{\partial \Delta f}{\partial Pc_i} \frac{\partial Pc_i}{\partial P'c_i} + \frac{\partial \Delta f}{\partial SR_i} \frac{\partial SR_i}{\partial P'c_i}$$

that results on

$$\frac{\partial \Delta f}{\partial P'c_i} = \frac{\partial \Delta f}{\partial Pc_i} - \frac{\partial \Delta f}{\partial SR_i} \quad (11)$$

A similar approach might be developed for wind type generators, exploiting the ANN inputs relation described by Figure 2 and equation (8):

$$\frac{\partial \Delta f}{\partial P'w_j} = \frac{\partial \Delta f}{\partial Pw_j} + \frac{\partial \Delta f}{\partial Nw_j} \frac{1}{Pw_j^{ind}} \quad (12)$$

There are still others constraints to be dealt with. Namely, constraint (4) means that if Pc_i is increased, the

global production from all the other generators should be decreased in order to keep the production/consumption equilibrium. Constraint (5) should also be considered, so that scenarios outputted by the control algorithm would always correspond to feasible power flow solutions. The other constraints (7 and 8) respect to wind production. Equation (7) states that the number Nw_j of operating units in equivalent wind generator j may assume integer values from zero to N_j - the number of available units in this grouping. Equation (8) states that all generators in group j are producing the same amount of power Pw_j^{ind} . Changing wind production for a given group of generators is then made on discrete steps, by turning on/off individual wind generators. To deal with all these constraints, and following at the same time the ultimate goal of increasing Δf , the subsequent strategy was adopted:

1. Compute ANN sensitivity for each individual ANN input;
2. For each controllable equivalent machine, evaluate the "composed" sensitivity using (12) for wind type and (11) for the remaining ones;
3. In order to satisfy constraint (4), the sum of all production changes must be null, that is:

$$\sum_i \Delta Pc_i + \sum_j \Delta Pw_j = 0 \quad (13)$$

This may be achieved by normalizing composed sensitivity indexes of controllable variables in such a way that new s_i (normalized sensitivity) values have zero mean. In this way, the power increment on group i will be given by:

$$\Delta P_i = h s_i \quad (14)$$

where h represents the gradient step and s_i is the normalized value of composed sensitivity. The new operation point will be given by $P_i + \Delta P_i$. Thus, the total power production change will be $\sum h s_i = h \sum s_i = 0$, because s_i is settled to have zero mean. However, during the iterative procedure, constraint (4) is only partially satisfied by the sensitivities normalization practice because:

1. Wind power may only assume discrete values (8). Generally, the new Pw_i will not be matched by one of the combinations $Nw_i Pw_i^{ind}$. In this case, PrevC algorithm will search these combinations and chooses the closest value to Pw_i . The obtained difference (usually a small value) is then distributed by non-wind controllable generators, following their s_i values.
2. In some iterations, the gradient step suggests a new operating point that may violate technical production limit, for non-wind generators. For instance, if a new set point P_i for equivalent generator i is above P_i^{max} , then $P_i = P_i^{max}$ and the remaining power is distributed again like in point 1.

5 NUMERICAL RESULTS

5.1 The Madeira Study Case

The quality of the developed approach is illustrated here through its application to the case of Madeira island. This power system is an isolated grid with a peak load of 120 MW and a minimum load of 42.8 MW, comprising utility owned and independent thermal units (134 MW), one independent waste to energy unit (6.4 MW), utility hydro units (46 MW), and utility owned and independent wind parks (15.3 MW) with asynchronous generators. The single line diagram of the transmission and generation system is presented in Figure 3. In this figure, P_w regard to the equivalent generators considered in the wind parks, and P_c to the equivalent generators considered in the remaining power plants. Due to space limitations the system data cannot be included but it can be obtained upon request.

For this power system, the following three disturbances were considered:

- Disturbance 1: short circuit in a selected bus at the western side of the island, causing the disconnection of P_{w1} to P_{w4} and P_{c2} to P_{c4} power plants;
- Disturbance 2: sudden disconnection of the generator in operation with the highest power capacity;
- Disturbance 3: short circuit in a selected bus at the eastern side of the island, causing the disconnection of all wind (P_{w1} to P_{w6}), and P_{c7} to P_{c8} power plants;

These disturbances were selected by the utility, since they are particular severe, once they may provoke large frequency drops, leading to load shedding activation, or to system instability. More precisely, disturbances 1 and 3 regard to situations where the dynamic security of the system is reduced in case of short-circuits that take place near to power production facilities, leading to these facilities disconnection (due to under-voltage conditions). As wind parks sites are more expose to adverse climatic conditions, short-circuits usually take place near these facilities, and therefore these type of disturbances are more severe for operating conditions with high wind power production near the disturbance area. On the other hand, for disturbance 2, an increased wind power may contribute for system robustness, by increasing the system inertia and spinning reserve. The system was considered to lose security if the negative frequency deviations (Δf) go bellow -2 Hz.

The final vector of ANN inputs comprises 33 variables with information about:

- P_{load} – total active load;
- P_{wj} , N_{wj} – active power produced and number of operating units in each equivalent wind generator;
- P_{ci} , S_{Ri} – active power produced and spinning reserve in the remaining equivalent generators.

For disturbance 2, some other variables were additionally considered, in order to identify the disconnected generator and the amount of power loss.

5.2 Data Set Summary

With the procedure described in section 2, a total amount of 8028, 8491 and 7083 patterns were obtained for the data sets of Madeira, regarding disturbance 1, 2 and 3. For each DS, 70% of the data was randomly extracted for training the ANN, and the remaining 30% for performance evaluation purposes (testing set). The number of obtained secure/insecure patterns are presented in Table 1.

	Secure	Insecure
Disturbance 1	6616	1412
Disturbance 2	8046	445
Disturbance 3	4908	2175

Table 1 : Number of obtained secure/insecure OP in the DS

5.3 Security Assessment Performance

An ANN was trained for each of the considered disturbances. The obtained testing set performance of these ANN is presented in Table 2, in terms of the Mean Absolute Deviation (MAD), Root Mean Square Deviation (RMSD) and test Classification Errors.

	Disturb. 1	Disturb. 2	Disturb. 3
MAD	0.023	0.033	0.047
RMSD	0.037	0.057	0.100
Total Error (%)	0.33	0.28	1.46
False alarm error (%)	0.30	0.0	1.35
Missed alarm error (%)	0.48	5.28	1.71

Table 2 : Security assessment performance

5.4 Preventive Control Results

Figure 4 shows the results of two successful examples of the application of PrevC algorithm for the case of disturbance 1. Each graphic corresponds to a particular initial operating point. Each line within a graphic represents the power produced by the available controllable generators; the other generators (independent-or switched off) are not shown. Columns represent frequency deviation Δf . One may observe the Δf value increasing during iteration process until it passes the security threshold -2 Hz. However, there were also some cases for which PrevC was not able to find a secure solution. This may happen because, in some situations, it is not simply possible to reach security on the base of exchanging power among available generators.

From the analysis of the results presented in Figure 4, we can observe that the preventive control application suggested to moved the system into the security region by increasing the spinning reserve of the Diesel units, since they are the ones that control frequency in the network. The other renewable power units usually do not participate in frequency control.

6 CONCLUSIONS

In this paper it was presented a robust and innovative approach to deal, in an effective way, with the identification of preventive control solutions for a

networks that includes large renewable power penetration (not fully controllable). The solutions obtained consisted in redispatches, involving also the on/off control of renewable units.

The robustness of the approach results, in part, from the quality of the generated data set, and from the capability in dealing with control restrictions of the different types of power units.

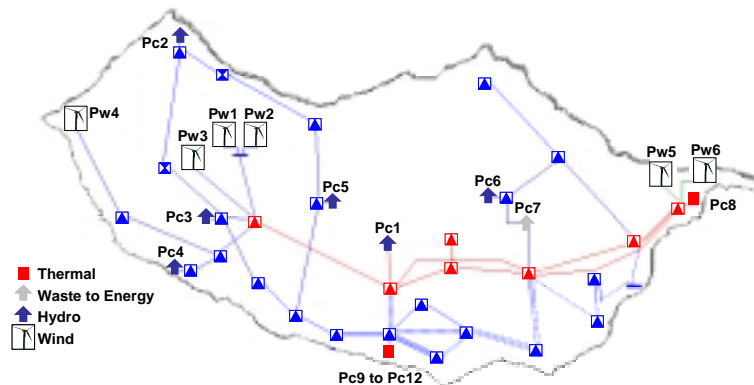

Figure 3 : Madeira power system

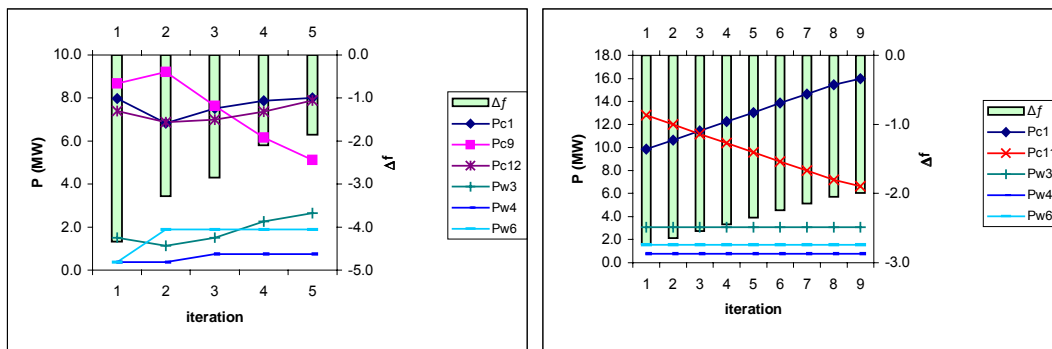

Figure 4 : Successful examples of application of PrevC algorithm

In this research, the identification of dynamic secure unit commitment solutions is also a matter of concern. This is performed by exploiting the ANN security assessment tool, through its integration in the general optimization procedure, where the tool used to find out the solution is based on a genetic algorithm approach.

The development of these kind of applications is nowadays of crucial importance due to the increase of system integration of non-fully controllable power units, like wind power production. Its future application into very large systems is a next step in the research under development. The preventive control procedure is also able to find out a robust solution for several disturbances, provided that a feasible security domain exists.

REFERENCES

[1] N. Hatziaargyriou et al., "Preliminary Results From The More Advanced Control Advice Project For Secure Operation Of Isolated Power Systems With Increased Renewable Energy Penetration And Storage – More Care", IEEE Power Tech, vol. 4, paper 317, September 2001, Porto – Portugal

[2] J. N. Fidalgo, J. A. Peças Lopes, V. Miranda, "Neural Networks Applied To Preventive Control Measures For The Dynamic Security Of Isolated Power Systems With Renewables", IEEE Transactions on Power Systems, Vol. 11, No. 4, November 1996

[3] J. A. Peças Lopes, M. H. Vasconcelos, "On-line Dynamic Security Assessment based on Kernel Regression Trees", Proc. of IEEE PES, Winter Meeting 2000, Singapore, January 2000

[4] J. N. Fidalgo, J. A. Peças Lopes, V. Miranda and L. B. Almeida, "Fast assessment of transient stability margins by a neural network approach", Proc. 11th PSCC, Avignon, France, Aug 1993

[5] Louis A. Wehenkel, "Automatic Learning Techniques in Power Systems", Kluwer Academic Publishers, ISBN 0-7923-8068-1, 1998

[6] V. Van Acker, S. Wang, J. McCalley, G. Zhou, M. Mitchell, "Data Generation using Automated Security Assessment for Neural Networks Training", Proc. of North American Power Conference, 1997

[7] F. M. Silva, L. B. Almeida, "Acceleration Techniques For The Backpropagation Algorithm", In *Neural Networks*, L. B. Almeida and C. J. Wellekens (Eds.), Springer-Verlag, 1990

[8] D. E. Rumelheart et. al., "Learning Internal Representations By Error Propagation", In *Parallel Distributed Processing*, Mit Press, Cambridge, Ma, USA, 1986

[9] Simon Haykin, *Neural Networks: A Comprehensive Foundation*, 2nd ed., Prentice-Hall, 1999.

Acknowledgments

The authors express their gratitude to the EU-DGXII for funding the project N°:NNE5-1999-00726 "MORE CARE".