



UNIVERSITÀ DEGLI STUDI DI TORINO

This is an author version of the contribution published on:

Crudo D.; Bosco V.; Cavaglia G.; Mantegna S.; Battaglia L.; Cravotto G.
Process intensification in food industry: hydrodynamic and acoustic
cavitation for fresh milk treatment
AGRO FOOD INDUSTRY HI-TECH (2014) 25

The definitive version is available at:

http://www.teknoscienze.com/pages/af-journal-home.aspx#.VQ_4PtKG_LI

DANIELE CRUDO¹, VALENTINA BOSCO¹, GIULIANO CAVAGLIÀ¹, STEFANO MANTEGNA², LUIGI BATTAGLIA² AND GIANCARLO CRAVOTTO^{2,*}

*Corresponding author

1. E-PIC S.r.l. Torino, Via Schina 15, Torino, 10143, Italy.

2. University of Torino, Dipartimento di Scienza e Tecnologia del Farmaco, Via Giuria 9, Torino, 10125, Italy.

Process intensification in the food industry: hydrodynamic and acoustic cavitation in fresh milk treatment

KEYWORDS: hydrodynamic cavitation, flow-ultrasound, fresh cow milk, homogenization, microorganism inactivation

ABSTRACT: Cavitation phenomena, which are commonly connected to erosion effects in fluid-flow systems, can be valid non-conventional mild disinfection processes for the treatment of fresh milk, clear juices and aqueous beverages. In this work, two flow-through reactors for hydrodynamic and ultrasonic cavitation have been tested in an attempt to achieve the simultaneous pasteurization and homogenization of fresh cow milk at low temperature and in a modified atmosphere. In this work, hydrodynamic cavitation in a loop reactor gives up to 88% microorganism inactivation when working at 6 bar pressure in a CO₂ atmosphere for 30 min. Acoustic cavitation in a ultrasonic flow reactor (Sonotube[®], power 370 W) gave microorganism abatement percentages of 95% in 10 min. Fast and efficient homogenization occurred in both loop reactors. An additional, and important, advantage of these techniques is the fact that they can easily be scaled-up for industrial applications.

INTRODUCTION

Fresh milk is a perishable foodstuff that requires rapid industrial treatment to make it shelf stable. The classic dairy industry processes used to produce milk at an affordable price are homogenisation and pasteurization. Standard homogenisation is used to reduce the size of fat globules and consists of forcing the liquid through a narrow gap (100–300 mm) in a homogenisation valve at an up-stream pressure of about 20–60 MPa. Thermal treatment, which is used to reduce microbial spoilage, presents several drawbacks (protein denaturation, decrease in nutritional values etc.). These facts have prompted the development of non-thermal procedures which aim to combine both homogenisation and pasteurization steps in a single run. Hydrodynamic and acoustic cavitation can potentially address this need (1). Ultrasound and hydrodynamic cavitation technologies have increasingly been adopted in industrial beverage and food processing. Cavitation is the mechanism by which the desired effects occur in liquid foods. Microorganism killing, enzyme activity inhibition, wine maturation, emulsification and crystallization all rely on the mechanism of cavitation (2). In cavitation treatment, bubble collapse generates high-energy microenvironments and accompanying hot spots, shock waves, micro-jets and shear forces. In hydrodynamic cavitation, a liquid is forced to pass into suitable orifices in which the kinetic energy of the fluid is amplified with increasing bulk pressure; when liquid pressure falls to its vapour pressure, bubbles are generated. Downstream from the restriction, the fluid decreases in velocity, recovers pressure and bubbles collapse in a confined area. According to Shah *et al.* (3) and assuming linear pressure recovery downstream from the restriction, bubbles are exposed to P_{∞} , which represents the pressure in the liquid away from the bubbles:

$$P_{\infty} = P_v + \frac{P_2 - P_v}{(L/V)} t$$

where P_v is the vapour pressure of the liquid, P_2 is the recovered pressure downstream from the restriction, L is the distance of pressure recovery, V is the mean velocity of the fluid in the pipeline and t is time. Cavitation number, σ , is the dimensionless parameter which characterizes hydrodynamic cavitation (4):

$$S = \frac{P_2 - P_v}{\frac{1}{2} \rho_l v_0^2}$$

where ρ_l is the density of the liquid and v_0 is the mean velocity of the fluid at the restriction.

Ideally, cavitation inception occurs when the cavitation number is equal to 1 and cavitation intensity increases below unity, however, in reality, cavitation inception can start at $\sigma > 1$, as dissolved gases and impurities act as points of nucleation for bubble generation (5).

To maximize the cavitation volume, a small amount of gas can also be injected into the restriction (6). Gas injection has a direct effect on nucleation and the phase of bubble collapse, which controls the intensity of the cavitation events. Gases

with low solubility in the liquid medium, high polytropic constant and low thermal conductivity enhance cavitation effects (5).

In acoustic cavitation, the liquid is exposed to acoustic pressure generated by an ultrasonic transducer; the oscillating sinusoidal pressure field, P_{∞} , can be mathematically expressed as reported by Shah *et al.* (3):

$$P_{\infty} = P_0 - P_a \sin(2\pi ft)$$

where P_0 is static pressure, P_a is peak amplitude pressure and f is oscillation frequency. The sinusoidal wave is composed of a decompression semi-period, in which bubbles are generated, and a compression semi-period, in which P_{∞} increases and bubbles collapse. The bubble response for an oscillating pressure field is also oscillatory (7); when bubbles of a certain size are exposed to a frequency corresponding to that of their resonance they violently collapse. In both hydrodynamic and acoustic cavitation, it is possible to generate transient (or inertial) or non-inertial cavitation; transient cavitation occurs when bubbles are generated and rapidly collapse, whilst non-inertial cavitation happens when bubbles are forced to oscillate, when the intensity of the external pressure field is insufficient to make the bubbles collapse.

The aim of this study is to verify the effects of hydrodynamic and acoustic cavitation on homogenization and microorganism inactivation in fresh untreated milk. The scope is therefore to develop a fast and cost effective process which would be an alternative to thermal treatment and reduce energy consumption, without altering the product's organoleptic and nutritional properties.

Milly *et al.* have proven the high potential hydrodynamic cavitation has in microorganism inactivation on skimmed milk, apple juice and tomato juice (8, 9). Often microorganisms tend to form agglomerates where the external microorganisms act as a protective barrier against biocides. Arrojo *et al.* (10) have shown that cavitation produces shocks that break these agglomerates, isolating the individual bacteria. Once the clusters are broken, the efficiency of carbon dioxide increases microorganism termination. Higher temperatures stimulate the diffusivity of carbon dioxide and increase cell membrane fluidity to make penetration easier. Lethality is improved by the enhanced mass transfer rate in the cavitation volume. Based on this principle, some of the authors have patented the cavitation process SANIFLUX® (11) which exploits the enhancing effect of carbon dioxide forced through one or more cavitation elements.

Ashokkumar and co-workers have described the process's outstanding potential in treating dairy ingredients in a continuous sonication process at 20 kHz (power up to 4 kW, flow rates from 200 to 6000 mL/min) using a dedicated flow-through reactor (12). The efficacy of continuous flow high-intensity ultrasound treatment had previously been touched upon by Villamiel and de Jong and applied to milk homogenization and enzyme inactivation (13).

Nowadays, industrial food beverage processes using acoustic cavitation are feasible only by means of flow methods.

MATERIALS AND METHOD

Hydrodynamic cavitation reactor

The hydrodynamic cavitation unit used for this series of experiments is shown in Figure 1. The fresh milk is pumped from a feed tank to the cavitation element by a double diaphragm pump. Pressure at the cavitation element inlet, and thus the flow rate, is controlled by means of a control valve installed on the recycle line which connects the pump directly back to the feed tank. The treated fluid can be either recycled to the feed tank, in case of multiple passes through the cavitation element (closed loop operation), or to the discharge tank, for single pass tests (open loop operation). The unit also includes CO₂ and Ar gas inlets and their relative flasks.



Figure 1. Hydrodynamic cavitation pilot unit

The tested cavitation elements are of the sharp orifice plate type or Venturi tube type, both equipped with gas inlets located upstream of the cavitation element. The milk flows vertically through the cavitation element, to ensure it is 100% in the liquid phase in the discharge chamber where bubbles collapse. The design of the cavitation chamber strongly influences the cavitation process and is crucially important in determining both the number of the cavitation events and the generated pulse pressure. Since bubbles are generated on the edges of the holes, the latter's shape should be made to maximize the "perimeter/area" ratio. Orifice plates consist of stainless steel discs, of approximately the same free cross-sectional area, that are 1 mm thick and contain one or more holes; one plate with one centered circular hole, with a diameter of 1.3 mm, one plate with one centered rectangular hole, with dimensions of 2.35 x 0.5 mm and one plate with two centered rectangular holes, with dimension of 0.5 x 1.2 mm (each hole). Venturi tubes have a convergent angle of 25 degrees, a circular or a rectangular throat and a divergent angle of 6 degrees; the circular throat has a diameter of 1.3 mm, the rectangular one has dimensions of 2.35 x 0.5 mm. Figure 2 depicts a schematic diagram of the hydrodynamic cavitation reactor.

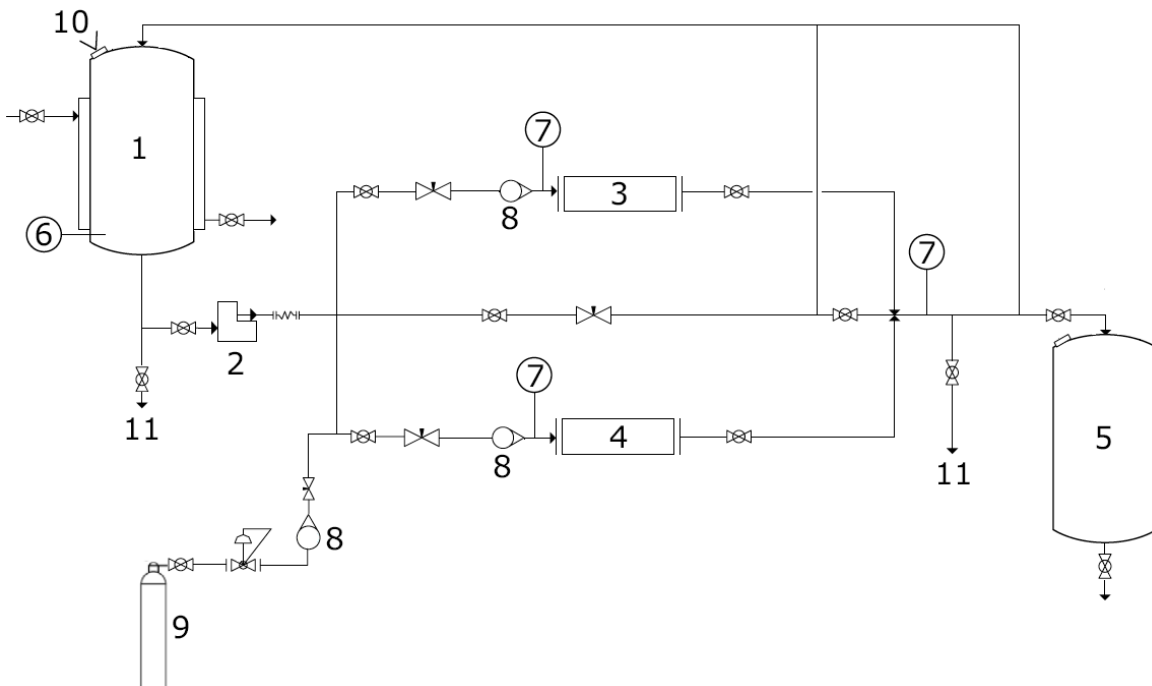

1	Feeding tank	7	Manometer
2	Double membrane pump	8	Flow regulation valve
3	Cavitation unit A	9	Gas flask
4	Cavitation unit B	10	Feeding inlet
5	Product recovery tank	11	Samples outlet
6	Thermometer		

Figure 2. Schematic diagram of hydrodynamic cavitation reactor.

Sonochemical reactor

The ultrasonic flow-reactor used was the Sonotube® (Synetude – Chambéry, France) a US-reactor made in a classic “T” shape with a transducer working at 35 kHz and a volume of 70 ml (Figure 3) (14). The temperature was kept constant in the 30-37°C range by external cooling. All the main reactor components are depicted in Figure 4.



Figure 3. Ultrasonic

flow-reactor (Sonotube®)

HF CABLE

Generator
supplying alternating tension to
the piezoelectric ceramic disks

Piezoelectric transducer
to convert electric
energy into mechanical
vibration

Booster to enhance
to enhance the
displacement
amplitude

Sonotrode to transmit
the ultrasonic vibration
to the liquid

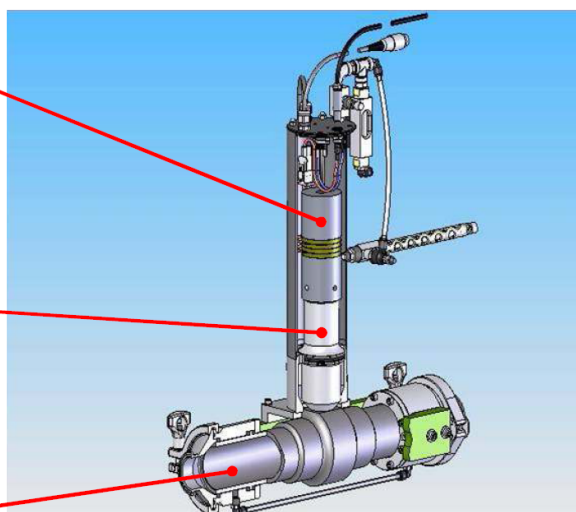

Figure 4. Schematic diagram of the Sonotube®

EXPERIMENTAL PROCEDURES

Hydrodynamic cavitation reactor

Experimental tests were executed on untreated fresh milk, directly supplied by a dairy-farm, without any thermal, mechanical or physical pre-treatment.

It is known that cavitation intensity, collapse magnitude and the number of free radicals generated during cavitation treatment all depend on the operating parameters and on the liquid's physical-chemical properties (15). It is also known from scientific literature (16, 17) that the main parameters which affect the efficiency and the overall hydrodynamic cavitation yield are: pressure at the inlet to the cavitation element, the physical-chemical properties of the liquid, initial nuclei radius, geometry of the restriction and presence of dissolved gasses.

Immediately before each experiment, a solution of sodium hypochlorite 15% was circulated in the reactor (10 min), then discharged and the reactor was washed with abundant purified water. The original microorganism content of untreated fresh milk ranged from 15,000 to 100,000 cfu/ml. During the treatment, the feeding tank (1 in Figure 2) was kept 20°C by circulating a thermostating liquid through the external jacket.

According to Taguchi's method and for the reasons stated above (18), three independent parameters have been identified which aid in the comparison of the performance of all the available cavitation elements:

- pressure at the inlet to the cavitation element
- treatment time
- the type of gas injected into the cavitation element restriction, in a quantity equal to 5% of the total volume of treated milk.

Taguchi's experiment type matrix is reported in Table 1 below.

Entry	Inlet pressure (bar)	Treatment time (min)	Gas
1	5	1	Ar
2	5	15	CO ₂
3	5	30	-
4	6	1	CO ₂
5	6	15	-
6	6	30	Ar
7	7	1	
8	7	15	Ar
9	7	30	CO ₂

Table 1. Taguchi's experiment matrix for hydrodynamic cavitation

Sonochemical reactor

Acoustic cavitation experimental tests were performed by feeding fresh milk into the Sonotube® ultrasonic reactor, for continuous flow operation, as was done for hydrodynamic cavitation in its respective machinery.

Acoustic cavitation tests were performed by following the full factorial experiment matrix portrayed in Table 2 below and by analyzing the effects of the following parameters on the process:

- ultrasonic applied power
- treatment time.

Entry	Applied power (W)	Treatment time (min)
1	240	1
2	240	10
3	240	5
4	320	1
5	320	10

6	320	5
7	370	1
8	370	10
9	370	5

Table 2. Full factorial matrix of experiments for acoustic cavitation

RESULTS: COMPARISON AND DISCUSSION

Two samples, at two different sampling points, were taken at each test, before and after treatment, in order to compare total microorganism content and evaluate the total number of bacteria killed by cavitation treatment. Total bacteria content was analysed at the Istituto Zooprofilattico del Piemonte (Turin) on a Bactoscan™ instrument and the homogenization effect on the milk fat portion was investigated, after each treatment, by optical microscopy with a DM2500 microscope (Leica, Germany) equipped with a Motic 480 camera, and laser light scattering analysis (Brookhaven, New York, USA).

It was observed that increases in treatment time and supply pressure to cavitation elements, which ultimately correspond to an increase in the intensity of cavitation, improves microorganism inactivation efficiency. The experimental results indicate that carbon dioxide assisted hydrodynamic cavitation can destroy up to 88% of the total bacteria content. However, it must be said that further optimization of both cavitation element geometry and operating conditions is possible and will most probably lead to complete bacterial inactivation. Table 3 below reports the best results in terms of bacteria inactivation.

Data are expressed as the following:

Microorganism inactivation: $(C_0 - C_f)/C_0$

C_0 = initial microorganism content (cfu/mL)

C_f = final microorganism content (cfu/mL)

Type of cavitation element	Inactivation efficiency
Plate with two centered rectangular holes	0.82
Plate with one centered rectangular hole	0.88
Plate with one centered circular hole	0.86
Venturi tube with a circular restriction	0.75
Venturi tube with rectangular restriction	0.83

Table 3. Inactivation efficiency after 30 min under a CO₂ atmosphere (6 bar).

As far as acoustic cavitation with the sonotube reactor is concerned, the best results were achieved by treating the fresh milk for 10 minutes at ultrasound power settings of 320 W and 370 W which gave microorganism abatement percentages of 90% and 95% respectively.

While performing bacteria inactivation, both hydrodynamic and acoustic cavitation can also ensure a high degree of product homogenization by reducing fat particle size to the nano-scale and uniformly dispersing them inside the milky substrate.

Table 4 a comparison of each technique's conditions and required energy

Method	Holdup volume L	Flow volume L/min	Time min	Power density W/L	Energy density Wh/L	Pump pressure bar	Generator power W
hydrodynamic cavitation	12	2	30	2	1	6	-
ultrasound	0.31 (US tube 70 mL)	0.17	10	1194	199	-	370

Table 4. General features of hydrodynamic cavitation and ultrasound processes.

A standard pasteurization system with a plate type heat exchanger has a flow volume of about 15-16 L/min and an energy density of 3 Wh/L. A standard homogenization system may have the same flow volume of 16.6 L/min with a pump pressure of 260 bar and an energy density of 11 Wh/L.

Figures 5 and 6 show fat particle size before and after acoustic and hydrodynamic cavitation treatment for a treatment time of 10 minutes and an applied power of 320 W, and for a treatment time of 10 minutes and an applied power of 370 W respectively.

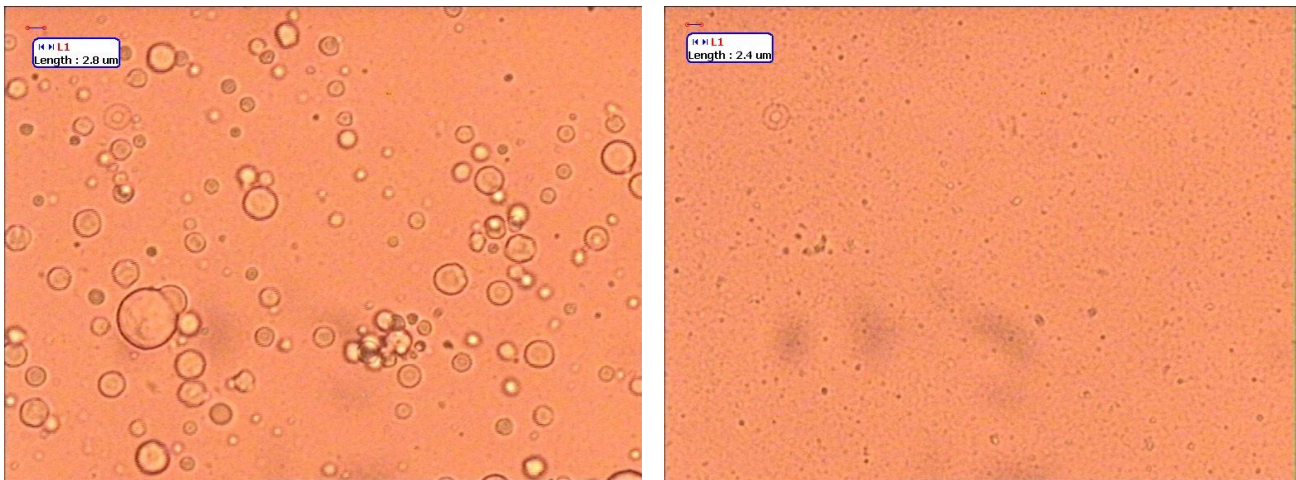

Figure 5. Comparison of milk that has been left untreated and milk that has been treated by acoustic cavitation at 320 W for a treatment time of 10 minutes (630x magnification)

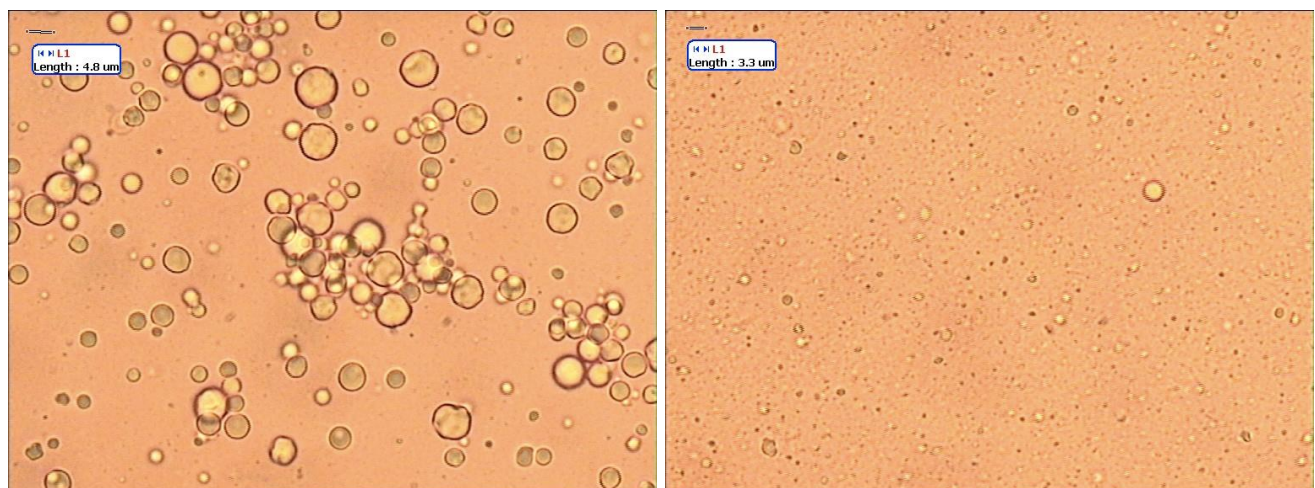

Figure 6. Comparison of milk that has been left untreated and milk that has been treated by hydrodynamic cavitation: plate with one centred rectangular hole, 6 bar inlet pressure, treatment time 30 minutes, with CO₂ injection (630 x magnification)

An internal sensorial panel test was carried out in five separate sessions. Twelve students previously trained on conventionally homogenised/pasteurised milk and untreated milk, evaluated all the samples. The panellists were asked to compare the taste of samples from hydrodynamic and acoustic cavitation treatment with those from standard treatments. In all cases the treatment under hydrodynamic cavitation received a full positive evaluation for taste perception, while the samples treated with ultrasound were considered acceptable by all the panellists despite a slight metallic taste. No rancid taste was described.

CONCLUSIONS

The present investigation has shown that hydrodynamic and acoustic cavitation, performed in loop reactors, can be effective techniques for both microorganism inactivation and homogenization in fresh untreated milk. In hydrodynamic cavitation, the percentage of microorganism abatement depends on the number of cavitation events per volume unit, which is mainly related to the inlet pressure towards the cavitation element, to the geometry of the restriction and to the volume of vapor generated in the cavitation element restriction. The plate with a single centred rectangular hole produced the greatest quantity of vapor and was accordingly able to reduce microorganism content by up to 88%, when CO₂ was injected. The inactivation efficiency of acoustic cavitation carried out in the loop-reactor Sonotube[®], is more efficient (95% after only 10 min) however it required much higher applied power. For this reason the scaling up of hydrodynamic cavitation combined with a suitable gas would appear to be more feasible.

At these operative conditions fat particle size is reduced to nano-scale dimensions and uniformly dispersed.

REFERENCES

1. A. Shanmugam, J. Chandrapala, M. Ashokkumar, "The effect of ultrasound on the physical and functional properties of skim milk" *Innov. Food Sci. Emerging Technol.* **16**, 251-258 (2012).
2. *Ultrasound Technologies for Food and Bioprocessing*, Ed. by H. Feng, G.V. Barbosa-Cánovas, J. Weiss. Springer Science Business Media, LLC (2011), ISBN 978-1-4419-7471-6.
3. Y.T. Shah, A. B. Pandit, V. S. Moholkar, 1999. "Cavitation reaction engineering" Springer.
4. D.V. Pinjari, A.B. Pandit, "Cavitation milling of natural cellulose to nanofibrils" *Ultrason. Sonochem.* **17**, 845–852 (2010).
5. P.R. Gogate, 2010. "Hydrodynamic cavitation for food and water processing", food bioprocess technology.
6. K.S. Kumar, V.S. Moholkar, "Conceptual design of a novel hydrodynamic cavitation reactor" *Chem. Eng. Sci.* **62**, 2698–2711 (2007).
7. A. Osterman, M. Dular, B. Sirok, "Numerical Simulation of a Near-Wall Bubble Collapse in an Ultrasonic Field". *J. Fluid Sci. Technol.* **4**, 210–221 (2009).
8. P.J. Milly, R.T. Toledo, M.A. Harrison, D. Armstead, "Inactivation of Food Spoilage Microorganisms by Hydrodynamic Cavitation to Achieve Pasteurization and Sterilization of Fluid Foods" *J. Food Sci.* **72**, 414–422 (2007).
9. P.J. Milly, R.T. Toledo, W.L. Kerr, D. Armstead, "Hydrodynamic Cavitation: Characterization of a Novel Design with Energy Considerations for the Inactivation of *Saccharomyces cerevisiae* in Apple Juice" *J. Food Sci.* **73**, 298–303 (2008).
10. S. Arrojo, Y. Benito, A. Martinez Tarifa, "A parametrical study of disinfection with hydrodynamic cavitation", *Ultrason. Sonochem.* **15**, 903–908 (2008).
11. G. Cavaglia, D. Crudo, V. Bosco, Patent application: PCT/IB2012/050594 (priority date: 10/02/2011)
12. B. Zisu, R. Bhaskaracharya, S. Kentish, M. Ashokkumar, "Ultrasonic processing of dairy systems in large scale reactors" *Ultrason. Sonochem.* **17**, 1075–1081 (2010).
13. M. Villamiel, P. de Jong, "Influence of high-intensity ultrasound and heat treatment in continuous flow on fat, proteins, and native enzymes of milk" *J. Agric. Food Chem.* **48**, 472-478 (2000).
14. E. Calcio Gaudino, D. Carnaroglio, L. Boffa, G. Cravotto et al. "Efficient H₂O₂/CH₃COOH oxidative desulfurization/denitrification of liquid fuels in sonochemical flow-reactors". *Ultrason. Sonochem.* DOI: 10.1016/j.ultsonch.2013.04.009
15. P.R. Gogate, "Application of cavitation reactors for water disinfection: current status and path forward", *J. Envir. Manag.* **85**, 801–815 (2007).
16. P.R. Gogate, "Cavitation: an auxiliary technique in wastewater treatment schemes", *Adv. Environ. Res.* **6**, 335–358 (2002).
17. P.R. Gogate, A.B. Pandit, "A review and assessment of hydrodynamic cavitation as a technology for the future", *Ultrason. Sonochem.* **12**, 21–27 (2005).
18. R. Ranjit, 1990, "A Primer on the Taguchi Method". Society of Manufacturing engineers.