

**stichting
mathematisch
centrum**



AFDELING NUMERIEKE WISKUNDE
(DEPARTMENT OF NUMERICAL MATHEMATICS)

NW 110/81

AUGUSTUS

W.J.A. MOL

SMOOTHING AND COARSE GRID APPROXIMATION PROPERTIES OF
MULTIGRID METHODS

kruislaan 413 1098 SJ amsterdam

Printed at the Mathematical Centre, 413 Kruislaan, Amsterdam.

The Mathematical Centre, founded the 11-th of February 1946, is a non-profit institution aiming at the promotion of pure mathematics and its applications. It is sponsored by the Netherlands Government through the Netherlands Organization for the Advancement of Pure Research (Z.W.O.).

Smoothing and coarse grid approximation properties of multigrid methods

by

W.J.A. Mol

ABSTRACT

In this report some smoothing processes, which are used in multigrid methods, are analysed with the smoothing analysis of BRANDT. The smoothing processes are applied to some model problems: The Poisson, anisotropic diffusion and convection diffusion equations.

Furthermore, an estimate is given of the Galerkin coarse grid approximation.

Finally, some remarks are given about these and some other theoretical results in comparison with experiments with multigrid methods.

KEY WORDS & PHRASES: *multigrid methods, smoothing operator, coarse grid operator, approximate inverse, incomplete LU-decomposition, Galerkin approximation*

CONTENTS

1. INTRODUCTION	
2. SMOOTHING ANALYSIS	3
3. COARSE GRID APPROXIMATION ANALYSIS	11
4. FINAL REMARKS	15
REFERENCES	17

1. INTRODUCTION

In a previous report MOL [6] some multigrid methods are proposed. Numerical experiments have shown that these methods are efficient and robust, in the sense that they do not need to be adapted to the problem at hand.

In this report more theoretical arguments will be given for the incomplete LU-decomposition as smoothing operator and the Galerkin approximation as coarse grid operator.

In chapter 2 the smoothing processes which are used in the experiments with multigrid methods are analysed with the smoothing analysis of BRANDT [1].

In chapter 3 an estimate is given of the Galerkin coarse grid approximation in the context of the convergence proof of WESSELING [7,8].

In chapter 4 some remarks are given about theory and practice of multigrid methods.

2. SMOOTHING ANALYSIS

2.1. Smoothing analysis in general

A computational grid Ω^k and a corresponding set of grid functions U^k are defined by:

$$(2.1.1) \quad \Omega^k = \{(x_1, x_2) \mid x_i = m_i \cdot 2^{-k}, m_i = 0(1)2^k, i = 1, 2\},$$

$$(2.1.2) \quad U^k = \{u^k: \Omega^k \rightarrow \mathbb{R}\}.$$

We consider a linear system of equations which originates from the discretization of a 2nd order elliptic boundary value problem on the given grid. Let this system be denoted by:

$$(2.1.3) \quad A^k u^k = f^k.$$

The system is solved by a stationary defect correction process:

$$(2.1.4) \quad (u^k)^{(v+1)} = G^k(u^k)^{(v)} + B^k f^k, \quad v = 0, 1, 2, \dots$$

with B^k the approximate inverse and G^k the amplification matrix:

$$(2.1.5) \quad G^k = I^k - B^k A^k.$$

The error $(e^k)^{(v)} = u^k - (u^k)^{(v)}$ satisfies:

$$(2.1.6) \quad (e^k)^{(v+1)} = G^k(e^k)^{(v)} \quad v = 0, 1, 2, \dots$$

We will omit the grid number k and the iteration index v if no confusion is possible. The error in a point $(i_1 \cdot 2^{-k}, i_2 \cdot 2^{-k}) \in \Omega^k$ before application of a smoothing step can be represented by a Fourier series as follows:

$$(2.1.7) \quad e_{i_1 i_2} = \sum_{s_1, s_2 = -M}^M c_{s_1 s_2} \exp\{I(i_1 \theta_{s_1} + i_2 \theta_{s_2})\},$$

with $\theta_{s_1} = \frac{2s_1 - 1}{2M+1} \pi$, $\theta_{s_2} = \frac{2s_2 - 1}{2M+1} \pi$ and $M = 2^{k-1}$.

If we have periodic boundary conditions and constant coefficients, the error \hat{e} after application of the smoothing operator is:

$$(2.1.8) \quad \hat{e}_{i_1 i_2} = \sum_{s_1, s_2 = -M}^M \hat{c}_{s_1 s_2} \exp\{I(i_1 \theta_{s_1} + i_2 \theta_{s_2})\},$$

with

$$(2.1.9) \quad \hat{c}_{s_1 s_2} = \mu(\theta_{s_1}, \theta_{s_2}) c_{s_1 s_2}.$$

The smoothing factor $\bar{\mu}$ of BRANDT [1] is defined by:

$$(2.1.10) \quad \bar{\mu} = \sup_{(\theta_1, \theta_2) \in F} |\mu(\theta_1, \theta_2)|,$$

with

$$(2.1.11) \quad F = \{(\theta_1, \theta_2) \mid -\pi \leq \theta_1, \theta_2 \leq \pi, |\theta_1| \geq \frac{\pi}{2} \text{ or } |\theta_2| \geq \frac{\pi}{2}\}.$$

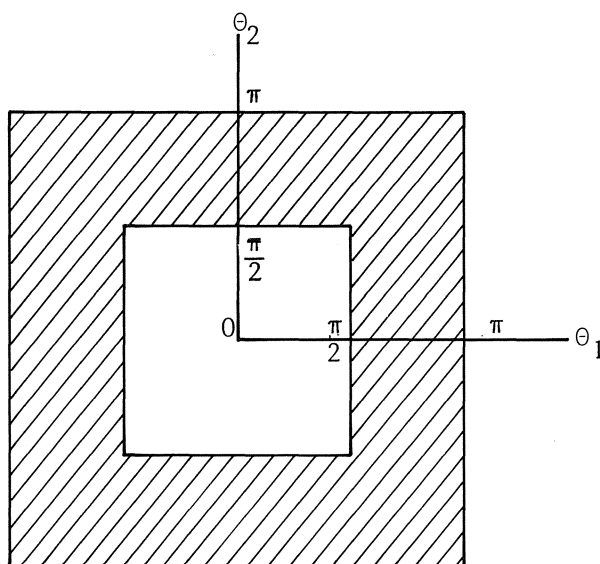

Figure 2.1.1. Frequency region F

For convenience F is not restricted to the discrete set of values $\theta_{s_1}, \theta_{s_2}$ occurring in (2.1.7) and (2.1.8).

2.2. Smoothing analysis of the APINV-process

The APINV smoothing process is described in MOL [6]. The approximate inverse B is such that

$$(2.2.1) \quad BA = I + C,$$

with I the identity and C a rest matrix with a small norm. The amplification matrix G is

$$(2.2.2) \quad G = -C.$$

Suppose A is a 5-point Toeplitz-matrix. G is also a Toeplitz-matrix with coefficients $\gamma_{(j_1, j_2)}$. Let J_γ be the set (j_1, j_2) for which $\gamma_{(j_1, j_2)} \neq 0$.

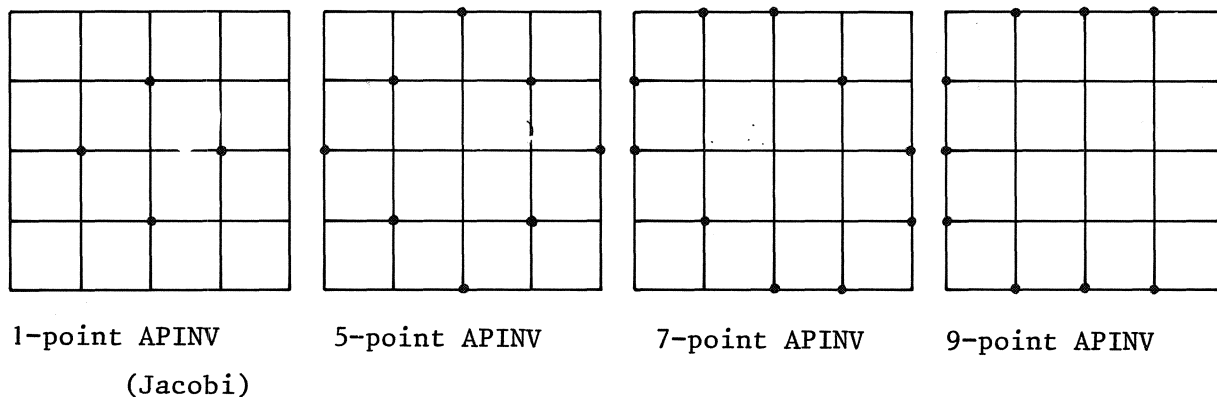

Figure 2.2.1. Difference molecules of G . J_γ is marked with dots.

The smoothing factor $\bar{\mu}$ is in the APINV case

$$(2.2.3) \quad \bar{\mu} = \sup_{(\theta_1, \theta_2) \in F} \left| \sum_{J_\gamma} \gamma(j_1, j_2) \exp\{I(j_1 \theta_1 + j_2 \theta_2)\} \right|$$

2.3. Smoothing analysis of the ILU, SGS and SLGS - processes.

The incomplete LU process ILU has an approximate inverse

$$(2.3.1) \quad B = (LU)^{-1},$$

with L, U the ILU- decomposition of A . This decomposition is such that

$$(2.3.2) \quad A = LU - R,$$

with R a rest matrix with a small norm. The amplification matrix G is:

$$(2.3.3) \quad G = (LU)^{-1} R.$$

L and U are constructed by a standard LU-decomposition algorithm writing zero outside a non-zero pattern. The rows of A , which correspond with points of the grid Ω , are arranged in lexicographic order.

Suppose A is a 5-point Toeplitz-matrix with coefficients σ_j , $j \in J_\sigma = \{(0,0), (1,0), (-1,0), (0,1), (0,-1)\}$. The rest matrix R has coefficients ρ_j , $j \in J_\rho$.

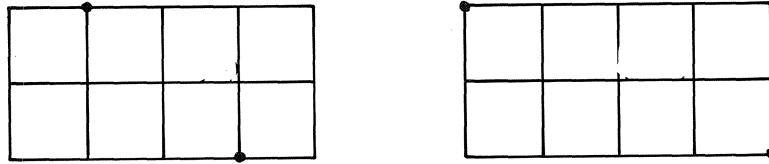

Figure 2.3.1. Difference molecules of R . J_ρ is marked with dots.

An ILU-smoothing step is defined by:

$$(2.3.4) \quad LU \hat{e} = (A+R)\hat{e} = Re.$$

The smoothing factor $\bar{\mu}$ is in the ILU-case:

$$(2.3.5) \quad \bar{\mu} = \sup_{(\theta_1, \theta_2) \in F} \frac{|\sum_{J_\rho} \rho(j_1, j_2) \exp\{I(j_1\theta_1 + j_2\theta_2)\}|}{|\sum_{J_\sigma} \sigma(j_1, j_2) \exp\{I(j_1\theta_1 + j_2\theta_2)\} + \sum_{J_\rho} \rho(j_1, j_2) \exp\{I(j_1\theta_1 + j_2\theta_2)\}|}$$

A symmetric Gauss Seidel (SGS) sweep consists of a Gauss Seidel sweep, where the points $(x_1, x_2) \in \Omega$ are taken in lexicographic order and another Gauss Seidel sweep in reverse order. Suppose $J_\sigma^+ = \{(1,0), (0,1)\}$ and $J_\sigma^- = \{(-1,0), (0,-1)\}$. The smoothing factor $\bar{\mu}$ of the SGS-process reads:

$$(2.3.6) \quad \bar{\mu} = \sup_{(\theta_1, \theta_2) \in F} \frac{|\sum_{J_\sigma^+} \sigma(j_1, j_2) \exp\{I(j_1\theta_1 + j_2\theta_2)\}|}{|\sigma(0,0) + \sum_{J_\sigma^-} \sigma(j_1, j_2) \exp\{I(j_1\theta_1 + j_2\theta_2)\}|} \cdot \frac{|\sum_{J_\sigma^-} \sigma(j_1, j_2) \exp\{I(j_1\theta_1 + j_2\theta_2)\}|}{|\sigma(0,0) + \sum_{J_\sigma^+} \sigma(j_1, j_2) \exp\{I(j_1\theta_1 + j_2\theta_2)\}|}$$

Finally, we give the smoothing factor of symmetric line Gauss Seidel (SLGS). One SLGS-sweep consists of 4 line Gauss Seidel sweeps: 2 x_1 -line relaxations (1 upwards and 1 downwards) and 2 x_2 -line relaxations (1 to the right and 1 to the left).

Suppose $J_\sigma^1 = \{(0,1), (-1,0), (0,-1)\}$, $J_\sigma^2 = \{(1,0), (-1,0), (0,-1)\}$, $J_\sigma^3 = \{(1,0), (0,1), (0,-1)\}$ and $J_\sigma^4 = \{(1,0), (0,1), (-1,0)\}$. The smoothing factor $\bar{\mu}$ reads:

$$(2.3.7) \quad \bar{\mu} = \sup_{(\theta_1, \theta_2) \in F} \frac{|\sigma(1,0)|}{|\sigma(0,0) + \sum_{J_\sigma^1} \sigma(j_1, j_2) \exp\{I(j_1\theta_1 + j_2\theta_2)\}|} \cdot \frac{|\sigma(0,1)|}{|\sigma(0,0) + \sum_{J_\sigma^2} \sigma(j_1, j_2) \exp\{I(j_1\theta_1 + j_2\theta_2)\}|} \cdot \frac{|\sigma(-1,0)|}{|\sigma(0,0) + \sum_{J_\sigma^3} \sigma(j_1, j_2) \exp\{I(j_1\theta_1 + j_2\theta_2)\}|} \cdot \frac{|\sigma(0,-1)|}{|\sigma(0,0) + \sum_{J_\sigma^4} \sigma(j_1, j_2) \exp\{I(j_1\theta_1 + j_2\theta_2)\}|}$$

2.4. Smoothing factor and efficiency for some model problems.

We consider the same problems as in the experiments in MOL [6]: the Poisson equation:

$$(2.4.1) \quad u_{x_1 x_1} + u_{x_2 x_2} = f,$$

the anisotropic diffusion equation (2 cases):

$$(2.4.2a) \quad u_{x_1 x_1} + \varepsilon u_{x_2 x_2} = f,$$

$$(2.4.2b) \quad \varepsilon u_{x_1 x_1} + u_{x_2 x_2} = f,$$

the convection diffusion equation (4 cases):

$$(2.4.3) \quad \varepsilon(u_{x_1 x_1} + u_{x_2 x_2}) - v_1 u_{x_1} - v_2 u_{x_2} = f$$

with

a) $v_1 = 1, v_2 = 0$	c) $v_1 = 1, v_2 = 1$
b) $v_1 = 0, v_2 = 1$	d) $v_1 = 1, v_2 = -1$

The problems (2.4.1), (2.4.2) and the 2nd derivatives in (2.4.3) are discretized by central differences, the first derivatives in (2.4.3) with Il'in's method. The Il'in coefficients are:

$$(2.4.4) \quad \alpha = -\coth\left(\frac{v_1 h}{2\varepsilon}\right) + \frac{2\varepsilon}{v_1 h}$$

$$\beta = -\coth\left(\frac{v_2 h}{2\varepsilon}\right) + \frac{2\varepsilon}{v_2 h}$$

The coefficients $\sigma_{(j_1, j_2)}$, $(j_1, j_2) \in J_\sigma$ are given in the following table.

Problem		$\sigma_{(0,-1)}$	$\sigma_{(-1,0)}$	$\sigma_{(0,0)}$	$\sigma_{(1,0)}$	$\sigma_{(0,1)}$
Poisson (2.4.1)		-1	-1	4	-1	-1
An. Diffusion (2.4.2)	a	$-\varepsilon$	-1	$2+2\varepsilon$	-1	$-\varepsilon$
	b	-1	$-\varepsilon$	$2+2\varepsilon$	$-\varepsilon$	-1
Conv. Diffusion (2.4.3)	a	$-\varepsilon$	$-\left\{\varepsilon + \frac{(1-\alpha)h}{2}\right\}$	$4\varepsilon - \alpha h$	$-\left\{\varepsilon - \frac{(1+\alpha)h}{2}\right\}$	$-\varepsilon$
	b	$-\left\{\varepsilon + \frac{(1-\beta)h}{2}\right\}$	$-\varepsilon$	$4\varepsilon - \beta h$	$-\varepsilon$	$-\left\{\varepsilon - \frac{(1+\beta)h}{2}\right\}$
	c	$-\left\{\varepsilon + \frac{(1-\beta)h}{2}\right\}$	$-\left\{\varepsilon + \frac{(1-\alpha)h}{2}\right\}$	$4\varepsilon - \alpha h + \beta h$	$-\left\{\varepsilon - \frac{(1+\alpha)h}{2}\right\}$	$-\left\{\varepsilon - \frac{(1+\beta)h}{2}\right\}$
	d	$-\left\{\varepsilon - \frac{(1-\beta)h}{2}\right\}$	$-\left\{\varepsilon + \frac{(1-\alpha)h}{2}\right\}$	$4\varepsilon - \alpha h + \beta h$	$-\left\{\varepsilon - \frac{(1+\alpha)h}{2}\right\}$	$-\left\{\varepsilon + \frac{(1+\beta)h}{2}\right\}$

Table 2.4.1. Coefficients $\sigma_{(j_1, j_2)}$ for the model problems.

In figure 2.4.1 we look at the matrix structures of A for small ε .

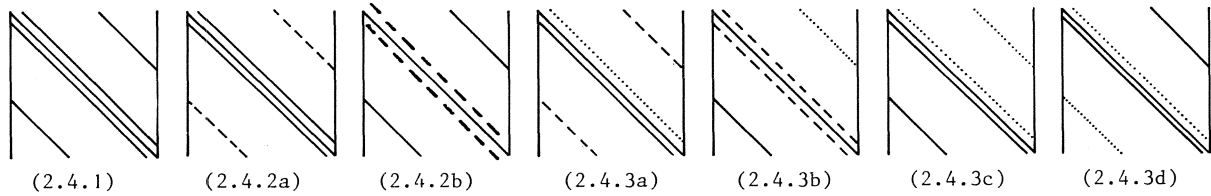

Figure 2.4.1. Matrix structures of A for the model problems

_____ $0(1)$ coefficients
 - - - - - $0(\epsilon)$ coefficients
 $0(e^{-1/\epsilon})$ coefficients

In table 2.4.2 we list the smoothing factor $\bar{\mu}$ for the smoothing processes and the model problems. The perturbation parameter ϵ varies up to 10^{-4} . Mesh size h is $1/16$.

The smoothing factor of SGS for the Poisson equation is well-known. Furthermore, we recognize the smoothing factor of SLGS for the anisotropic diffusion equations (see BRANDT [1]). Some results (5p-ILU and SGS for Poisson, anisotropic diffusion case b and convection diffusion equation) are the same as in HEMKER [3].

Remark that Jacobi and 5p-APINV are bad smoothers. It can be proved that $\sum_{j_1, j_2} \gamma(j_1, j_2) = 1$. Therefore $\bar{\mu} = 1$ for $(\theta_1, \theta_2) = (\pi, \pi)$ for all possible combinations of $\gamma(j_1, j_2)$ in case of Jacobi and 5p- APINV.

5p- ILU and SGS coincidence asymptotically for anisotropic and convection diffusion equations.

Note that 7p- ILU has different $\bar{\mu}$ for the cases a and b of the anisotropic and convection diffusion equation.

We see that $\bar{\mu} \rightarrow 0$ for $\epsilon \rightarrow 0$ in the following cases:

Anisotropic diffusion equation case b : 7p- ILU

Convection diffusion equation case a : SLGS

case b : 7p-ILU, SLGS

case c : 5p- ILU, 7p - ILU, SGS, SLGS

case d : SLGS

In order to judge which method is the best, we have to compare the efficiencies of the methods. In MOL [6] the number of operations per grid point of a smoothing method a_s is calculated for the general 5-point A matrix case when the coefficients are variable.

Problem	ϵ	$\bar{\mu}$						
		Jacobi 5p- APINV	7p- APINV	9p- APINV	5p- ILU	7p- ILU	SGS	SGLS
Poisson		1.	0.8063	0.5313	0.2035	0.1259	0.2500	0.0222
An.Diff	0.1	1.	0.9261	0.9548	0.4775	0.2734	0.6970	0.1389
	0.01	1.	0.9902	0.9993	0.7676	0.5959	0.9612	0.1922
a	0.001	1.	0.9990	1.	0.9162	0.7407	0.9960	0.1992
	0.0001	1.	0.9999	1.	0.9723	0.7622	0.9996	0.1999
	0.1	1.	0.9261	0.9548	0.4775	0.1648	0.6970	0.1389
	0.01	1.	0.9902	0.9993	0.7676	0.1226	0.9612	0.1922
b	0.001	1.	0.9990	1.	0.9162	0.0242	0.9960	0.1992
	0.0001	1.	0.9999	1.	0.9723	0.0026	0.9996	0.1999
Conv.Diff	1.	1.	0.8060	0.5320	0.2034	0.1258	0.2497	0.0222
	0.1	1.	0.7994	0.6497	0.2295	0.1579	0.2389	0.0165
a	0.01	1.	0.9404	0.9793	0.4532	0.4157	0.4393	0.
	0.001	1.	0.9931	0.9997	0.4948	0.4904	0.4933	0.
	0.0001	1.	1.	1.	0.4995	0.4990	0.4993	0.
	1.	1.	0.8060	0.5320	0.2034	0.1252	0.2497	0.0222
	0.1	1.	0.7994	0.6497	0.2295	0.0955	0.2389	0.0165
b	0.01	1.	0.9404	0.9793	0.4532	0.0246	0.4349	0.
	0.001	1.	0.9931	0.9997	0.4948	0.0029	0.4933	0.
	0.0001	1.	1.	1.	0.4995	0.0003	0.4993	0.
	1.	1.	0.8083	0.5332	0.2015	0.1232	0.2478	0.0222
	0.1	1.	0.9183	0.6449	0.0905	0.0374	0.1197	0.0054
c	0.01	1.	1.	0.7373	0.	0.	0.	0.
	0.001	1.	1.	0.7373	0.	0.	0.	0.
	0.0001	1.	1.	0.7373	0.	0.	0.	0.
	1.	1.	0.8032	0.5332	0.2047	0.1271	0.2505	0.0222
	0.1	1.	0.6534	0.6449	0.3540	0.1978	0.3158	0.0054
d	0.01	1.	0.7373	0.7373	0.4473	0.2535	0.4473	0.
	0.001	1.	0.7373	0.7373	0.4473	0.2535	0.4473	0.
	0.0001	1.	0.7373	0.7373	0.4473	0.2535	0.4473	0.

Table 2.4.2. Smoothing factors for the model problems.

Method	Jacobi	5p-APINV	7p-APINV	9p-APINV	5p-ILU	7p-ILU	SGS	SLGS
a_s	9	20	24	28	13	17	18	56

Table 2.4.3. Number of operations per gridpoint for the smoothing methods (A has variable coefficients).

Because the test problems have constant coefficients, this operation count can be improved for these special cases. The efficiency τ_{10} (number of operations per grid point for 0.1 reduction of the error) is defined as

$$(2.4.5) \quad \tau_{10} = \frac{a_s}{|\log \bar{\mu}|}$$

In table 2.4.4 we consider the efficiencies of the methods for the Poisson, anisotropic diffusion ($\epsilon = 0.01$) and convection diffusion equation ($\epsilon = 0.001$).

Problem	Jacobi	5p-APINV	7p-APINV	9p-APINV	5p-ILU	7p-ILU	SGS	SLGS
Poisson	∞	∞	256	102	19	19	30	34
An. Diff. a	∞	∞	5611	92071	113	76	1047	78
($\epsilon = 0.01$) b	∞	∞	5611	92071	113	19	1047	78
Conv. Diff a	∞	∞	7981	214870	43	55	59	0
($\epsilon = 0.001$) b	∞	∞	7981	214870	43	7	59	0
c	∞	∞	∞	212	0	0	0	0
d	∞	∞	181	212	37	29	52	0

Table 2.4.4. Efficiency τ_{10}

On the basis of this table 5p-ILU, 7p-ILU and SLGS are more efficient than the other methods. For the Poisson case 5p-ILU and 7p-ILU have small τ_{10} . 7p-ILU is the best method for the anisotropic diffusion equation and SLGS the most efficient method for the convection diffusion equation.

Furthermore, it can be concluded that 5p-ILU, 7p-ILU and SLGS are robust: they are efficient for all problems. This is not true for the other smoothing methods.

3. COARSE GRID APPROXIMATION ANALYSIS

In WESSELING [7] a convergence proof is given of a multigrid method for a 2nd order linear elliptic partial differential equation (not necessary self adjoint) with variable coefficients in a rectangle. In WESSELING [8] a simplified proof is given for the self-adjoint and positive definite case.

The most difficult part of the proof is to estimate how well the coarse grid operator A^{k-1} approximates A^k i.e. to estimate $u^k - P^k u^{k-1}$ with $A^k u^k = f^k$ and $A^{k-1} u^{k-1} = R^k f^k$. P^k and R^k are the prolongation and the restriction operators respectively.

$$(3.1) \quad P^k : U^{k-1} \rightarrow U^k \quad R^k : U^k \rightarrow U^{k-1},$$

and A^{k-1} is the Galerkin approximation

$$(3.2) \quad A^{k-1} = (P^k)^T A^k P^k.$$

An important step in getting this estimate is to find a C_2 , as small as possible, for the following inequality:

$$(3.3) \quad \|u^k - P^k v^{k-1}\|_1 \leq C_2 2^{-k} \|u^k\|_2 \quad \forall v^{k-1} \in V^{k-1} \\ u^k \in V^k.$$

with

$$(3.4) \quad V^k = \{u^k : \Omega^k \rightarrow \mathbb{R} \mid u^k|_{\partial\Omega^k} = 0\}$$

and the following inner product and norms:

$$(u, v) = h^2 \sum_{i_1, i_2 = 0}^{2^k} u_{i_1 i_2} v_{i_1 i_2}, \quad h = 2^{-k},$$

$$(3.5) \quad \|u\|_0^2 = (u, u) \quad ; \quad \|u\|_1^2 = \sum_{i=1}^2 \|\Delta_i u\|_0^2$$

$$\|u\|_2^2 = \sum_{i,j=1}^2 \|\Delta_i \nabla_j u\|_0^2 .$$

Δ_i and ∇_i are forward and backward difference operators in x_i direction. The index k is omitted where there is no confusion.

Because all $v^{k-1} \in V^{k-1}$ are possible in inequality (3.3) we try

$$(3.6) \quad v^{k-1} = R^k u^k,$$

with R^k injection. P^k is the 7-point prolongation. Therefore we have

$$(PRu)_{2i_1, 2i_2} = u_{2i_1, 2i_2} \quad ; \quad (PRu)_{2i_1+1, 2i_2} = \frac{1}{2}(u_{2i_1+1, 2i_2} + u_{2i_1, 2i_2})$$

$$(3.7) \quad (PRu)_{2i_1, 2i_2+1} = \frac{1}{2}(u_{2i_1, 2i_2+1} + u_{2i_1, 2i_2})$$

$$(PRu)_{2i_1+1, 2i_2+1} = \frac{1}{2}(u_{2i_1+1, 2i_2} + u_{2i_1, 2i_2+1}).$$

Define

$$(3.8) \quad z = u - PRu$$

and

$$(3.9) \quad K = \Delta_1 \nabla_1 + \Delta_2 \nabla_2 - \Delta_1 \nabla_2 - \Delta_2 \nabla_1 .$$

The grid function z is :

$$z_{2i_1, 2i_2} = 0 \quad ; \quad z_{2i_1+1, 2i_2} = -\frac{h^2}{2} (\Delta_1 \nabla_1 u)_{2i_1+1, 2i_2}$$

$$(3.10) \quad z_{2i_1, 2i_2+1} = -\frac{h^2}{2} (\Delta_2 \nabla_2 u)_{2i_1, 2i_2+1} \quad ; \quad z_{2i_1+1, 2i_2+1} =$$

$$= -\frac{h^2}{2} (Ku)_{2i_1+1, 2i_2+1} .$$

The forward differences of z are:

$$\begin{aligned}
 (\Delta_1 z)_{2i_1, 2i_2} &= -\frac{h}{2} (\Delta_1 \nabla_1 u)_{2i_1+1, 2i_2} \\
 (\Delta_1 z)_{2i_1+1, 2i_2} &= \frac{h}{2} (\Delta_1 \nabla_1 u)_{2i_1+1, 2i_2} \\
 (\Delta_1 z)_{2i_1, 2i_2+1} &= \frac{h}{2} (\Delta_2 \nabla_2 u)_{2i_1, 2i_2+1} - \frac{h}{2} (Ku)_{2i_1+1, 2i_2+1} \\
 (3.11) \quad (\Delta_1 z)_{2i_1+1, 2i_2+1} &= -\frac{h}{2} (\Delta_2 \nabla_2 u)_{2i_1+2, 2i_2+1} + \frac{h}{2} (Ku)_{2i_1+1, 2i_2+1} \\
 (\Delta_2 z)_{2i_1, 2i_2} &= -\frac{h}{2} (\Delta_2 \nabla_2 u)_{2i_1, 2i_2+1} \\
 (\Delta_2 z)_{2i_1+1, 2i_2} &= \frac{h}{2} (\Delta_1 \nabla_1 u)_{2i_1+1, 2i_2} - \frac{h}{2} (Ku)_{2i_1+1, 2i_2+1} \\
 (\Delta_2 z)_{2i_1, 2i_2+1} &= \frac{h}{2} (\Delta_2 \nabla_2 u)_{2i_1, 2i_2+1} \\
 (\Delta_2 z)_{2i_1+1, 2i_2+1} &= -\frac{h}{2} (\Delta_1 \nabla_1 u)_{2i_1+1, 2i_2+2} + \frac{h}{2} (Ku)_{2i_1+1, 2i_2+1}.
 \end{aligned}$$

By using the inequality:

$$(3.12) \quad \left(\sum_i a_i \right)^2 \leq \sum_i \frac{1}{\alpha_i} \sum_i \alpha_i^2 a_i^2$$

we find

$$\begin{aligned}
 \sum_{i_1, i_2} (\Delta_1 z)_{2i_1, 2i_2+1}^2 &= \sum_{i_1, i_2} (\Delta_1 z)_{2i_1+1, 2i_2+1}^2 \leq \\
 \frac{h^2}{4} \left(\frac{1}{\alpha^2} + \frac{4}{\beta^2} \right) &\sum_{i_1, i_2} \left[\alpha^2 (\Delta_2 \nabla_2 u)_{2i_1, 2i_2+1}^2 + \beta^2 (\tilde{K}u)_{2i_1+1, 2i_2+1}^2 \right]
 \end{aligned}$$

$$\begin{aligned}
(3.13) \quad \sum_{i_1, i_2} (\Delta_2 z)^2_{2i_1+1, 2i_2+1} &= \sum_{i_1, i_2} (\Delta_2 z)^2_{2i_1+1, 2i_2+1} \leq \\
\frac{h^2}{4} \left(\frac{1}{\alpha^2} + \frac{4}{\beta^2} \right) \sum_{i_1, i_2} &[\alpha^2 (\Delta_1 \nabla_1 u)^2_{2i_1+1, 2i_2+1} + \beta^2 (\tilde{K}u)_{2i_1+1, 2i_2+1}] \\
(\tilde{K}u)_{2i_1+1, 2i_2+1} &= \{ (\Delta_1 \nabla_1 u)^2 + (\Delta_2 \nabla_2 u)^2 + (\Delta_1 \nabla_2 u)^2 + \\
&+ (\Delta_2 \nabla_1 u)^2 \}_{2i_1+1, 2i_2+1}
\end{aligned}$$

With (3.11) and (3.13) the 1-norm of z can be estimated by

$$\begin{aligned}
(3.14) \quad \|z\|_1^2 &\leq \frac{h^4}{4} \sum_{i_1, i_2} [(4+8 \frac{\alpha^2}{\beta^2}) \{ (\Delta_1 \nabla_1 u)^2_{2i_1+1, 2i_2+1} + \\
&+ (\Delta_2 \nabla_2 u)^2_{2i_1+1, 2i_2+1} \} + (16 + \frac{4\beta^2}{\alpha^2}) (\tilde{K}u)_{2i_1+1, 2i_2+1}]
\end{aligned}$$

Choose $\alpha = \gamma\beta$. From $4+8\gamma^2 = 16 + \frac{4}{\gamma^2}$ we find $\gamma = 1.33$. Then

$$\begin{aligned}
(3.15) \quad \|z\|_1^2 &\leq \frac{h^4}{4} 18.25 \sum_{i_1, i_2} [(\Delta_1 \nabla_1 u)^2_{2i_1+1, 2i_2+1} + (\Delta_2 \nabla_2 u)^2_{2i_1+1, 2i_2+1} + \\
&+ (\tilde{K}u)_{2i_1+1, 2i_2+1}] \leq 4.57 h^2 \|u\|_2^2 .
\end{aligned}$$

The constant C_2 in (3.3) is :

$$(3.16) \quad C_2 = 2.14$$

We have tried also other restrictions in (3.6), but they do not give better results.

4. FINAL REMARKS

In this chapter the theoretical results of chapter 2 and some other results from HEMKER [4] are compared with the experiments of MOL [6].

The smoothing methods, which are used in [6], are 7p-ILU, 7p-APINV and SGS. The average reduction factor r_{av} is used as a measure for the speed of convergence of the multigrid process. r_{av} is defined as follows:

$$(4.1) \quad r_{av} = \left(\frac{\|f - Au^{(v_0)}\|}{\|f - Au(0)\|} \right)^{1/v_0}, \quad v_0 \neq 0$$

$\|\cdot\|$ is the Euclidian norm and v_0 is the smallest integer such that

$$(4.2) \quad \|f - Au^{(v_0)}\| < 10^{-6}.$$

In table 4.1 a comparison is made between r_{av} and $\bar{\mu}$. The multigrid method from which r_{av} is computed has 1 coarse grid correction, no smoothing step before correction, 1 smoothing step after correction, 7 point restriction and prolongation and Galerkin coarse grid approximation.

We remark that r_{av} is smaller than $\bar{\mu}$. The smoothing factor is however the result of one-level analysis of the multigrid algorithm, while r_{av} is based on all levels of the algorithm. It is possible to generalize the smoothing analysis for more than 1 level (see FOERSTER, STUBEN and TROTTEBERG [2], HEMKER [5]).

Furthermore, it should be noted that the smoothing analysis applies to Toeplitz-matrices without considering the boundaries. In the experiments Dirichlet boundary conditions are used. This can also be a reason for the difference between r_{av} and $\bar{\mu}$.

Problem	7p-APINV		7p-ILU		SGS		
	r_{av}	$\bar{\mu}$	r_{av}	$\bar{\mu}$	r_{av}	$\bar{\mu}$	
Poisson	0.29	0.8063	0.020	0.1259	0.071	0.2500	
An. Diff	a	0.70	0.9902	0.014	0.5959	0.61	0.9612
($\epsilon=0.01$)	b	0.70	0.9902	1E-4	0.1226	0.61	0.9612
Conv. Diff	a	0.47	0.9931	0.003	0.4904	0.0056	0.4933
($\epsilon=0.001$)	b	0.47	0.9931	7E-5	0.0029	0.0043	0.4933
	c	0.47	1.	3E-9	0.	4E-9	0.
	d	0.47	0.7373	0.040	0.2535	0.25	0.4473

Table 4.1. Comparison between r_{av} of the multigrid process and $\bar{\mu}$ of the smoothing process.

From the experiments it appears that 7p-ILU as smoothing method is superior to SGS and 7p-APINV for all model problems. This can also be concluded from the smoothing analysis.

The smoothing analysis says that 7p-ILU is better in case of the Poisson and anisotropic diffusion equations, SLGS in case of the convection diffusion equations. In [6] no results are available for the multigrid method with SLGS as smoothing method. Therefore, it is not quite clear which smoothing method is the best: 7p-ILU or SLGS.

Another conclusion in [6] is that a multigrid method with Galerkin approximation is at least as fast as a multigrid method with finite differences as coarse grid operator. This fact corresponds with results in HEMKER [4]. He studies the effect of one coarse grid correction step on the Fourier components of the error and residual. He finds the following scheme:

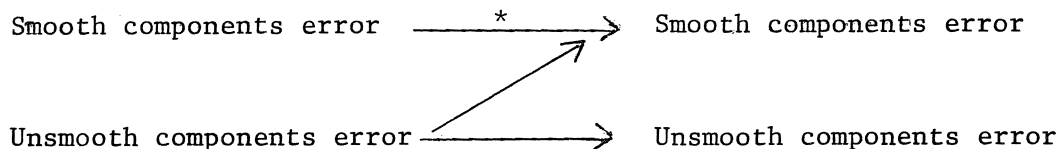

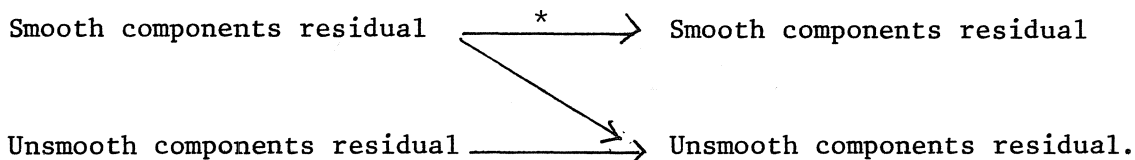

He shows that the arrows marked with * disappear when a Galerkin coarse grid operator is used.

The scheme also shows that for the error it is better to smooth before coarse grid correction, while for the residual smoothing after coarse grid correction is preferable. So far as the residual is concerned, this fact corresponds with the experiments in [6].

ACKNOWLEDGEMENT

The author wishes to thank prof. P. Wesseling for reading this manuscript and drs. P.M. de Zeeuw for his programming assistance.

REFERENCES

- [1] BRANDT, A., *Multi-level adaptive solutions to boundary value problems*, Math. Comp. 31 (1977), 333-390.
- [2] FOERSTER, H., K. STÜBEN & U. TROTTEBERG, *Non standard multigrid techniques using checkered relaxation and intermediate grids*, in: *Elliptic Problem Solvers*, M. Schultz ed., Academic Press, New York (1980).
- [3] HEMKER, P.W., *The incomplete LU-decomposition as a relaxation method in multi-grid algorithms*, in: *Boundary and Interior Layers-Computational and Asymptotic Methods*, J.J.H. Miller ed., Bode Press, Dublin (1980), 306-311.
- [4] HEMKER, P.W., *A note on defect correction processes with an approximate inverse of deficient rank*, Report NN-23/81, Mathematical Centre, Amsterdam (1981)

- [5] HEMKER, P.W., *On the convergence of the incomplete LU-relaxation in a multi-grid algorithm*, to be published as Report NW, Mathematical Centre, Amsterdam (1981).
- [6] MOL, W.J.A. *On the choice of suitable operators and parameters in multigrid methods*, Report NW-107/81, Mathematical Centre, Amsterdam (1981).
- [7] WESSELING, P., *The rate of convergence of a multiple grid method*. Conference on Numerical Analysis (Dundee 1979), in: Lecture Notes in Math. 773, G.A. Watson ed., Springer, Berlin & New York (1980), 164-184.
- [8] WESSELING, P., *Theoretical and practical aspects of a multigrid method*, Report NA-37, Delft University of Technology (1980).